



256Kx32 Static RAM CMOS, High Speed Module

FEATURES

- 256Kx32 bit CMOS Static RAM
 - Access Times: 12, 15, 20, and 25ns
 - Individual Byte Selects
 - Fully Static, No Clocks
 - t_{TL} Compatible I/O
- High Density Package with JEDEC Standard Pinouts
 - 72 Pin SIMM No. 175 (Angle)
 - 72 Pin ZIP No. 176
 - 72 Pin SIMM No. 354 (Straight)
- Single +3.3V ($\pm 10\%$) Supply Operation

DESCRIPTION

The EDI8F32259V is a high speed 8Mb Static RAM module organized as 256K words by 32 bits. This module is constructed from eight 256Kx4 Static RAMs in SOJ packages on an epoxy laminate (FR4) board.

Four chip enables (E0#-E3#) are used to independently enable the four bytes. Reading or writing can be executed on individual bytes or any combination of multiple bytes through proper use of selects.

The EDI8F32259V is offered in 72 pin ZIP/SIMM package which enables eight megabits of memory to be placed in less than 1.3 square inches of board space.

All inputs and outputs are t_{TL} compatible and operate from a single 3.3V supply. Fully asynchronous circuitry requires no clocks or refreshing for operation and provides equal access and cycle times for ease of use.

The ZIP and SIMM modules contain four P_D (Presence Detect) pins which are used to identify module memory density in applications where alternate modules can be interchanged.

PIN CONFIGURATIONS AND BLOCK DIAGRAM

FIG. 1

NC	1	E4#	37
NC	2	E3#	38
PD3	3	A17	39
PD4	4	A16	40
V _{SS}	5	G#	41
PD1	6	V _{SS}	42
PD2	7	DQ24	43
DQ0	8	DQ16	44
DQ8	9	DQ25	45
DQ1	10	DQ17	46
DQ9	11	DQ26	47
DQ2	12	DQ18	48
DQ10	13	DQ27	49
DQ3	14	DQ19	50
DQ11	15	A3	51
V _{CC}	16	A10	52
A0	17	A4	53
A7	18	A11	54
A1	19	A5	55
A8	20	A12	56
A2	21	V _{CC}	57
A9	22	A13	58
DQ12	23	A6	59
DQ4	24	DQ20	60
DQ13	25	DQ28	61
DQ5	26	DQ21	62
DQ14	27	DQ29	63
DQ6	28	DQ22	64
DQ15	29	DQ30	65
DQ7	30	DQ23	66
V _{SS}	31	DQ31	67
W#	32	V _{SS}	68
A15	33	NC	69
A14	34	NC	70
E2#	35	NC	71
E1#	36	NC	72

PD 1,2 = V_{SS}
PD 3, 4 = Open

PIN NAMES

A0-A17	Address Inputs
E0#-E3#	Chip Enables
W#	Write Enables
G#	Output Enable
DQ0-DQ31	Common Data Input/Output
V _{CC}	Power (+5V $\pm 10\%$)
V _{SS}	Ground

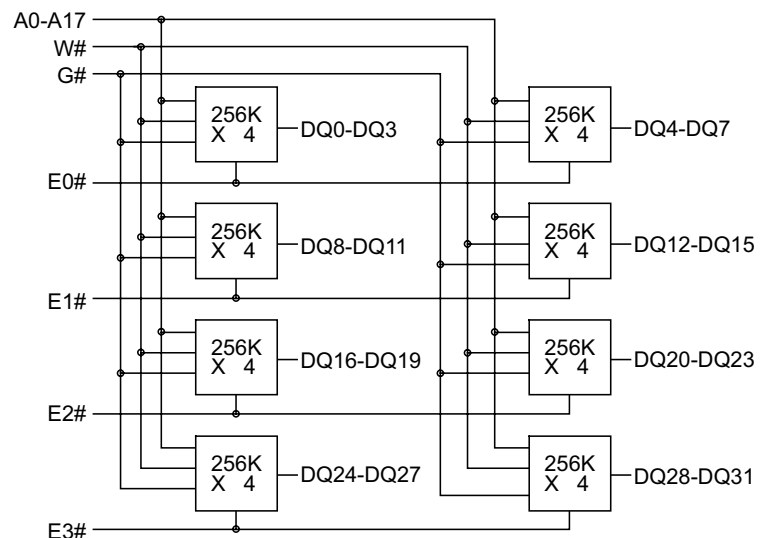



ABSOLUTE MAXIMUM RATINGS*

Voltage on any pin relative to V _{SS}	-0.5V to 4.6V
Operating Temperature t _A (Ambient) Commercial	0°C to +70°C
Storage Temperature, Plastic	-55°C to +125°C
Power Dissipation	2.5 Watt
Output Current	20 mA

*Stress greater than those listed under "Absolute Maximum Ratings" may cause permanent damage to the device. This is a stress rating only and functional operation of the device at these or any other conditions greater than those indicated in the operational sections of this specification is not implied. Exposure to absolute maximum rating conditions for extended periods may affect reliability.

RECOMMENDED DC OPERATING CONDITIONS

Parameter	Sym	Min	Typ	Max	Units
Supply Voltage	V _{CC}	3.0	3.3	3.6	V
Supply Voltage	V _{SS}	0	0	0	V
Input High Voltage	V _{IH}	2.2	--	V _{CC} +0.3V	V
Input Low Voltage	V _{IL}	-0.3	--	0.8	V

AC TEST CONDITIONS

Input Pulse Levels	V _{SS} to 3.0V
Input Rise and Fall Times	5ns
Input and Output Timing Levels	1.5V
Output Load	1t _{TL} , CL = 30pF

Note: For t_{EH0Z}, t_{GH0Z} and t_{WL0Z}, CL = 5pF)

DC ELECTRICAL CHARACTERISTICS

Parameter	Sym	Conditions	Min	Max 12-25	Units ns
Operating Power Supply Current	I _{CC1}	W#, E# = V _{IL} , I/O = 0mA, Min Cycle		800	mA
Standby (t _{TL}) Power Supply Current	I _{CC2}	E# ≥ V _{IH} , V _{IN} ≤ V _{IL} or V _{IN} ≥ V _{IH}		240	mA
Full Standby Power Supply Current CMOS	I _{CC3}	E# ≥ V _{CC} -0.2V V _{IN} ≥ V _{CC} -0.2V or V _{IN} ≤ 0.2V		40	mA
Input Leakage Current	I _{LI}	V _{IN} = 0V to V _{CC}	—	±80	µA
Output Leakage Current	I _{LO}	V I/O = 0V to V _{CC}	—	±20	µA
Output High Voltage	V _{OH}	I _{OH} = -4.0mA	2.4	—	V
Output Low Voltage	V _{OL}	I _{OL} = 8.0mA	—	0.4	V

Note: Typical: t_A = 25°C, V_{CC} = 5.0V

TRUTH TABLE

E#	W#	G#	Mode	Output	Power
H	X	X	Standby	HIGH Z	I _{CC3}
L	H	L	Read	D _{OUT}	I _{CC1}
L	L	X	Write	D _{IN}	I _{CC1}
L	H	H	Output Deselect	HIGH Z	I _{CC1}

CAPACITANCE

(f=1.0MHz, V_{IN}=V_{CC} or V_{SS})

Parameter	Sym	Max	Unit
Address Lines	CI	60	pF
Data Lines	CD/Q	20	pF
Chip Enable Line	CC	20	pF
Write Control Line	CN	60	pF

Note: These parameters are sampled, not 100% tested.



AC CHARACTERISTICS READ CYCLE

Parameter	Symbol		12ns		15ns		20ns		25ns		Units
	JEDEC	Alt.	Min	Max	Min	Max	Min	Max	Min	Max	
Read Cycle Time	t_{AVAV}	t_{RC}	12		15		20		25		ns
Address Access Time	t_{AVQV}	t_{AA}		12		15		20		25	ns
Chip Enable Access	t_{ELQV}	t_{ACS}		12		15		20		25	ns
Chip Enable to Output in Low Z (1)	t_{ELQX}	t_{CLZ}	3		3		3		3		ns
Chip Disable to Output in High Z (1)	t_{EHQZ}	t_{CHZ}		6		7		9		9	ns
Output Hold from Address Change	t_{AVQX}	t_{OH}	3		3		3		3		ns
Output Enable to Output Valid	t_{GLQV}	t_{OE}		6		7		9		9	ns
Output Enable to Output in Low Z (1)	t_{GLQX}	t_{OLZ}	0		0		0		0		ns
Output Disable to Output in High Z (1)	t_{GHQZ}	t_{OHZ}		6		7		9		9	ns

Note: 1. Parameter guaranteed, but not tested.

**FIG. 2
READ CYCLE 1 - W# HIGH, G#, E# LOW**

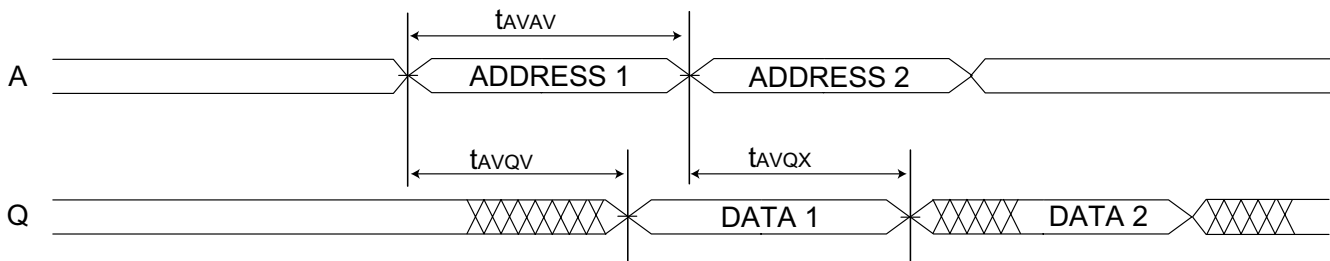

**FIG. 3
READ CYCLE 2 - W# HIGH**

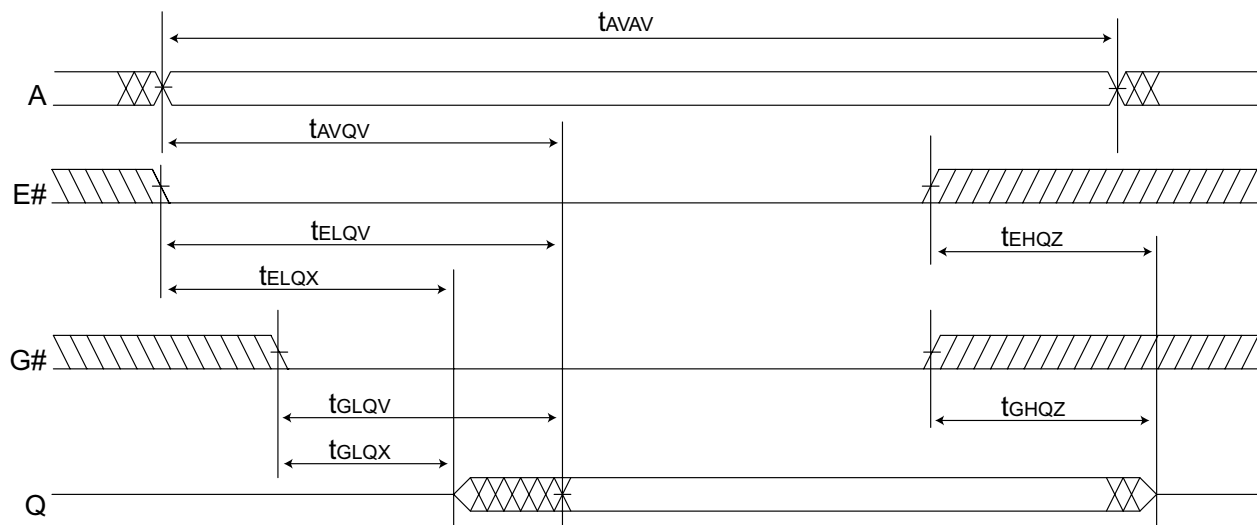

White Electronic Designs Corp. reserves the right to change products or specifications without notice.



AC CHARACTERISTICS WRITE CYCLE

Parameter	Symbol		12ns		15ns		20ns		25ns		Units
	JEDEC	Alt.	Min	Max	Min	Max	Min	Max	Min	Max	
Write Cycle Time	t _{AVAV}	t _{WC}	12		15		20		25		ns
Chip Enable to End of Write	t _{ELWH}	t _{CW}	8		9		10		10		ns
	t _{WLEH}	t _{CW}	8		9		10		10		ns
Address Setup Time	t _{AVWL}	t _{AS}	0		0		0		0		ns
	t _{AVEL}	t _{AS}	0		0		0		0		ns
Address Valid to End of Write	t _{AVWH}	t _{AW}	8		9		10		10		ns
	t _{AVEH}	t _{AW}	8		9		10		10		ns
Write Pulse Width	t _{WLWH}	t _{WP}	8		9		10		10		ns
	t _{WLEH}	t _{WP}	8		9		10		10		ns
Write Recovery Time	t _{WHAX}	t _{WR}	0		0		0		0		ns
	t _{EHAX}	t _{WR}	0		0		0		0		ns
Data Hold Time	t _{WHDX}	t _{DH}	3		3		3		3		ns
	t _{EHDX}	t _{DH}	3		3		3		3		ns
Write to Output in High Z (1)	t _{WLQZ}	t _{WHZ}	0	6	0	7	0	9	0	9	ns
Data to Write Time	t _{DVWH}	t _{DW}	6		7		8		8		ns
	t _{DVEH}	t _{DW}	6		7		8		8		ns
Output Active from End of Write (1)	t _{WHQX}	t _{WLZ}	3		3		3		3		ns

Note 1: Parameter guaranteed, but not tested.



FIG. 4
WRITE CYCLE 1 - W# CONTROLLED

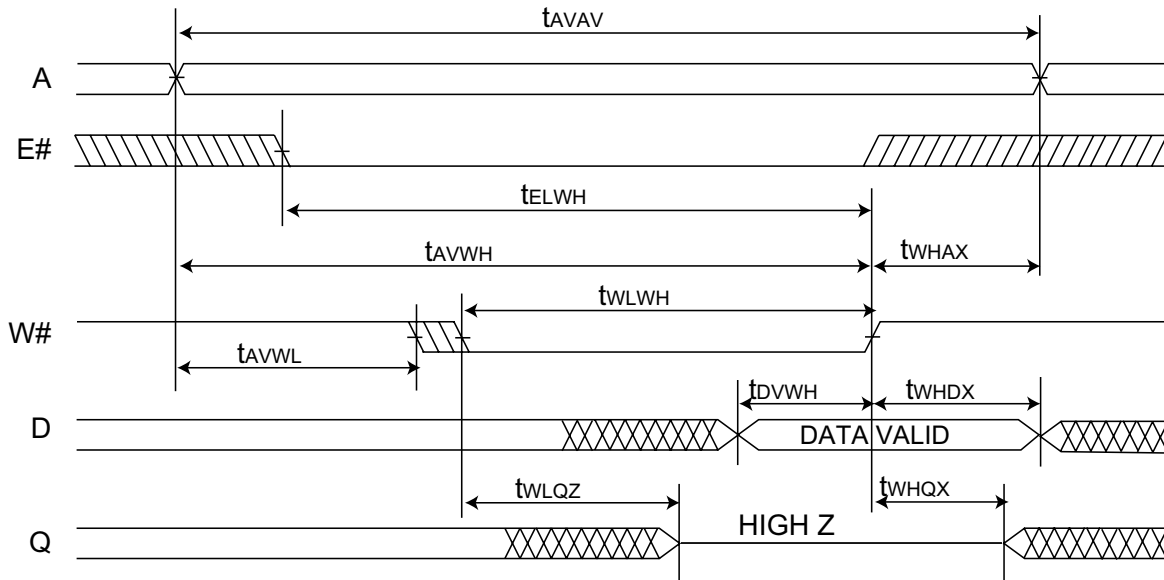
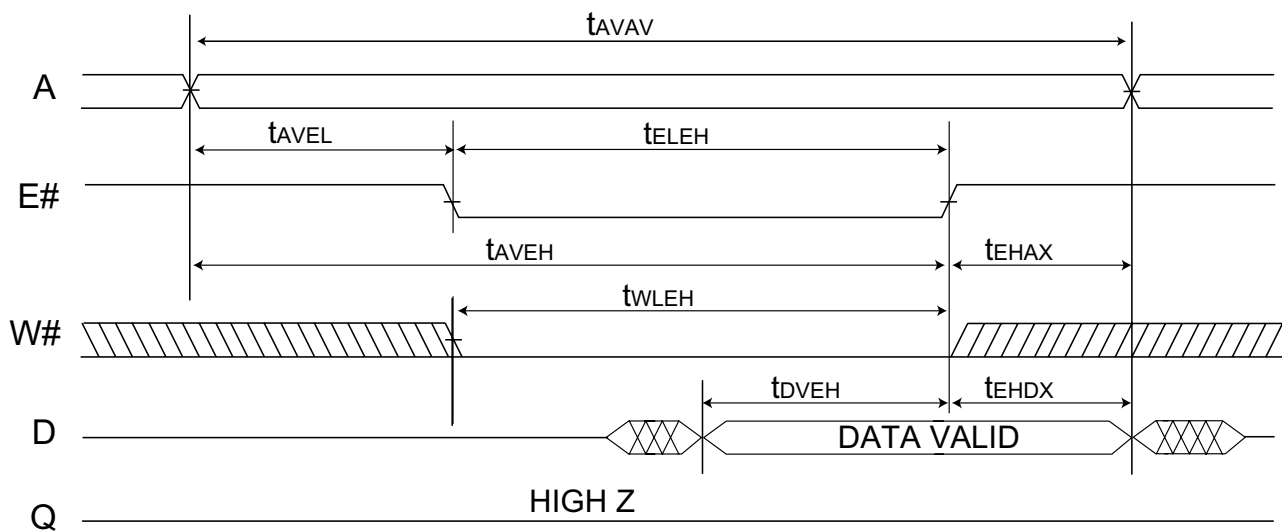

FIG. 5
WRITE CYCLE 2 - E# CONTROLLED





ORDERING INFORMATION

Part Number	Speed (ns)	Package No.
EDI8F32259V12MNC	12	176
EDI8F32259V15MNC	15	176
EDI8F32259V20MNC	20	176
EDI8F32259V25MNC	25	176
EDI8F32259V12MMC	12	354
EDI8F32259V15MMC	15	354
EDI8F32259V20MMC	20	354
EDI8F32259V25MMC	25	354
EDI8F32259V12MZC	12	175
EDI8F32259V15MZC	15	175
EDI8F32259V20MZC	20	175
EDI8F32259V25MZC	25	175

NOTE: 1. For Gold SIMM change form EDI8F to EDI8G.

PACKAGE DESCRIPTION

PACKAGE NO. 175: 72 PIN ZIP

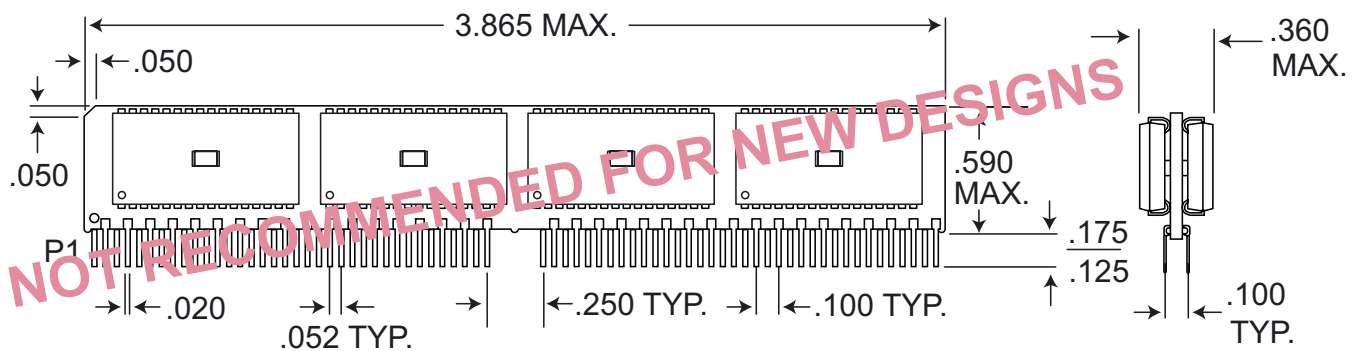



PACKAGE NO. 176: 72 PIN ANGLED

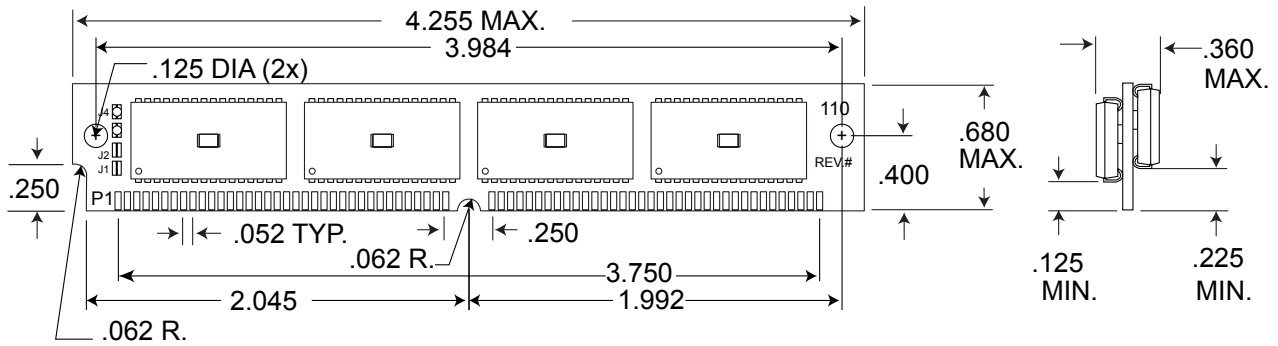

PACKAGE NO. 354: 72 PIN SIMM STRAIGHT

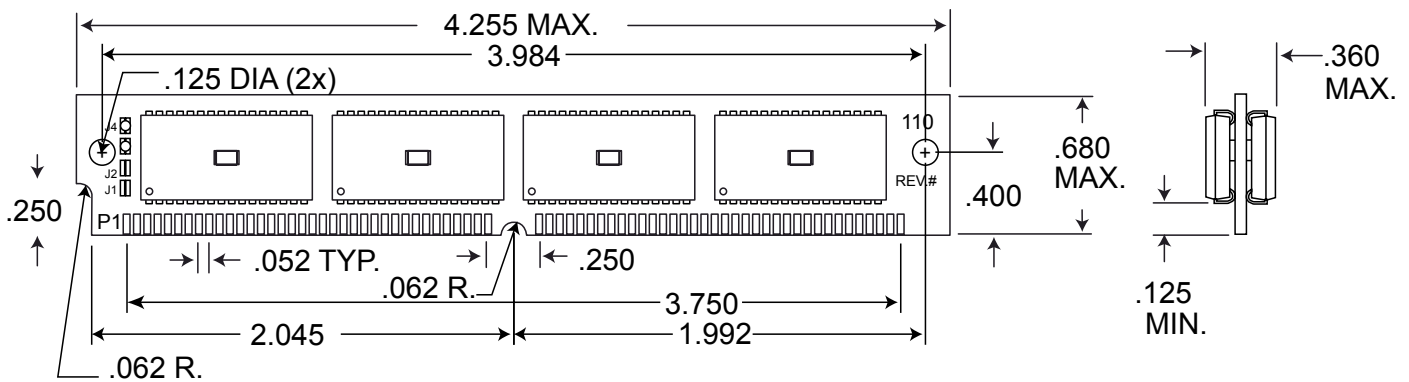

ALL DIMENSIONS ARE IN INCHES