

KILOVAC EV200 - 200/250 Amps ("Czonka III")

Make & Break Load Switching

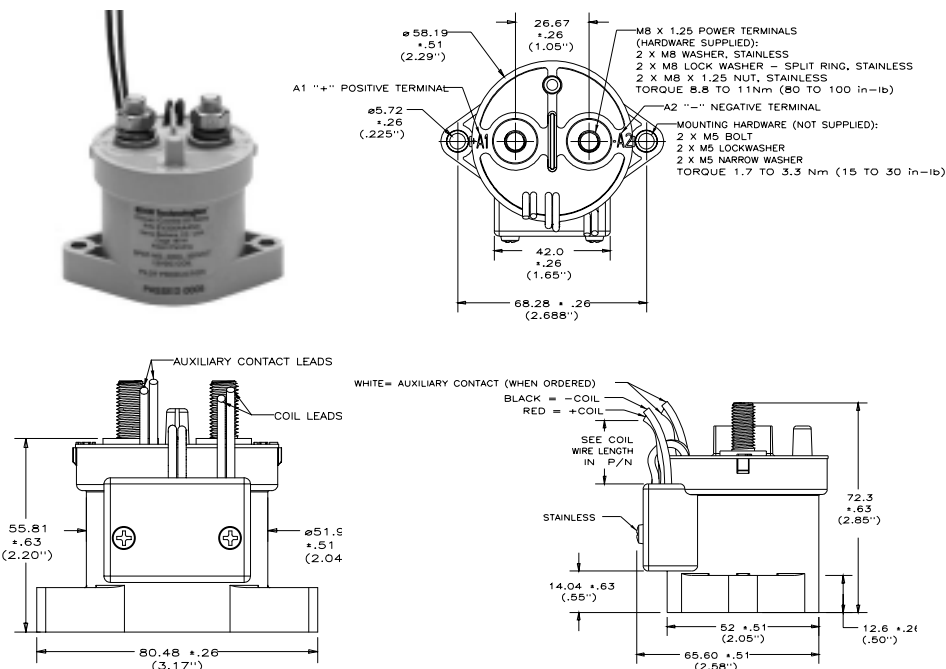

Features:

- **Low Cost** - lowest price sealed relay in the industry with its contact rating
- **Highest contact rating for its size** - 200/250 A carry, 2,000 A interrupt at 320 Vdc.
- **Optional Auxillary Contact** - Easy monitoring of power contact position
- **Built-In Coil Economizer** - Only 1.7 W hold power @ 12 Vdc making it ideal for battery powered systems. Models are available requiring external coil economizer for large volume applications
- **US and Canadian UL Recognized** - UL File No. E208033
- **CE Marked** for EC Applications
- **AIAG QS9000**, Design, Built & Approved
- **Hermetically Sealed** - Intrinsically safe, operates in explosive & harsh environments like salt, moisture, dust with no oxidation or contamination of coils or contacts providing stable contact resistance over years of use, including long periods of non-operation
- **Small & Lightweight** - smallest sealed relay in the industry with its current rating
- **No Coil Back EMF** - Built-in coil economizer limits back EMF to zero volts
- **Versatile Coil Connection** - Flying leads or optional connectors
- **Multiple use Applications** - Ideal for battery switching & back-up, DC voltage power control, circuit protection and safety

PRODUCT SPECIFICATIONS		
Part Number	Units	EV200
Contact Arrangement : Power Contacts		SPST-NO
Aux. Contacts		SPST-NO
Contact Form		A
Carry Current, Continuous, Max @ 85°C, 1/0 cable		200
100 Seconds	A	325 ^{1/}
10 Seconds	A	500 ^{2/}
Carry Current, Continuous, Max @ 50°C, 1/0 cable	A	250
300 Seconds	A	275
100 Seconds	A	400
10 Seconds	A	600
Starter Application (up to 10 repeats with 10 sec. off between)		
Inrush, 250 ms	A	2,000
Cranking, 10 sec	A	500
Make & Break Current (various voltages) ^{1/}	A	see back sheet
Break Current @ 320 Vdc ^{2/}	A	2,000, 1 cyc ^{4/}
Aux. Contact Current, max @ 30 Vdc/125 Vac	A	2 / 3
(no lower than 8V @ 100mA)	A	
Aux. Contact Resistance, max. 30 Vdc/125 Vac	A	.417/.150
Load Life	cycles	see back sheet
Mechanical Life	cycles	1 million
Contact Resistance, Max. (@200A)	mohms	.4
Contact Resistance, Typ. (@200A)	mohms	.1 - .3
Operate Time, 25°C		
Close (includes bounce) Typ.	ms	15
Bounce (after close only), Max.	ms	7
Release Time (includes arcing), Max. @ 2,000A	ms	12
Insulation Resistance @ 500 Vdc, Min.	Mohms	100 ^{2/}
Dielectric at Sea Level (leakage < 1mA)	Vrms	2,200
Shock, 11 ms 1/2 Sine (peak), operating	G's peak	20
Vibration, Sinusoidal (80-2000 Hz, peak)	G's	20
Operating Ambient Temperature Range	°C	-40 to +85
Weight, Nominal	pound (kg)	.95 (.43)

^{1/} Main Power Contacts
^{2/} 50 at end of life
^{3/} Estimated
^{4/} Does not meet dielectric & IR after test, 1,700 amp for unit with Aux. Contacts

EV200 COIL DATA				
Voltage (will operate)	9 to 36	32 to 95	48 to 95	Vdc
Voltage (max.)	36	95	95	Vdc
Pickup (close), max.	9.0	32	48	Vdc
Hold, Min.	7.5	22	34	Vdc
Dropout (open), min.	6.0	18	27	Vdc
Inrush, max.	3.8	1.3	.7	A
Holding, avg.	.13@12V, .07@24V	.03@48V	.02@72V	A
Inrush Time, max.	130	130	130	ms

PART NUMBER SELECTION						
Sample Part No.	EV200	A	A	A	N	A
Model	EV200					
Form						
A = Normally Open H = Normally Open with Aux.						
Coil Voltage						
A = 9 to 36 (1 = requires external coil economizer) D = 32 to 95 (2 = requires external coil economizer) J = 48 to 95 (3 = requires external coil economizer)						
Coil Wire Length						
A = 390 mm (15.3") B = 152 mm (6.0")						
Coil Terminal Connector						
N = No Connector B = Yazaki 7282-5558-10 male, 7114-4102-02, 7158-3030-50 +red is pin 2 (B length only) C = Molex Mini-fit Jr, 2 Ckt, Female 18-24, P/N 39-01-2020 & 39-00-0060 +red is pin 1 (A length only)						
Mounting & Power Terminals						
A = Bottom Mount & Male 10mm x 8 Terminals						

Estimated Make & Break Power Switching Ratings

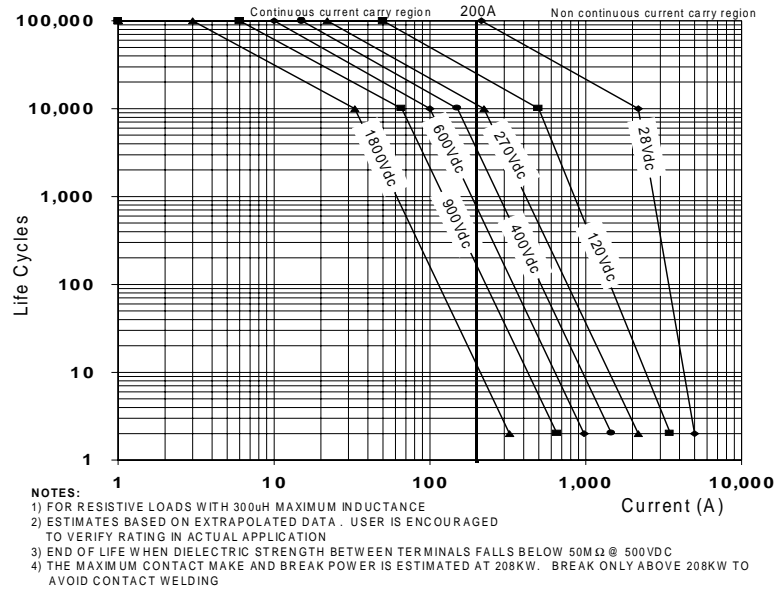

Electrical Load Life Ratings for Typical EV Applications

Make/Break Life Capacitive & Resistive Loads at 320 Vdc 1/ 2/		
@90% capacitive pre-charge (make only) see chart below	Cycles	50,000
@80% capacitive pre-charge (make only) see chart below	Cycles	50
@200 A make/break (2 consecutive, reverse polarity) 1/	Cycles	12
2,000 A - break only (1,700 A for Aux. Contact Model) 1/	Cycles	1*
Mechanical Life	Cycles	1,000,000

1/ Resistive load includes inductance L = 25 uH. Load @ 2500 A tested @ 200 uH.

2/ Life based on projected Weibull Life with 95% Reliability

* Does not meet dielectric & IR after test.

EV200 Capacitive Make Test Curves for Pre-Charged Motor Controller

