



128Kx8 Monolithic SRAM, SMD 5962-89598

FEATURES

- Access Times of 15*, 17, 20, 25, 35, 45, 55ns
- CS# and OE# Functions for Bus Control
- 2V Data Retention (EDI88128LPS)
- TTL Compatible Inputs and Outputs
- Fully Static, No Clocks
- Organized as 128Kx8
- Commercial, Industrial and Military Temperature Ranges
- Thru-hole and Surface Mount Packages JEDEC Pinout
 - 32 pin Ceramic DIP, 400 mil (Package 102)
 - 32 pin Ceramic DIP, 600 mil (Package 9)
 - 32 lead Ceramic ZIP (Package 100)
 - 32 lead Ceramic SOJ (Package 140)
- 32 pad Ceramic LCC (Package 141)
- 32 lead Ceramic Flatpack (Package 142)
- Single +5V (±10%) Supply Operation
The EDI88128CS is a high speed, high performance, 128Kx8 megabit density Monolithic CMOS Static RAM.

The device has eight bi-directional input-output lines to provide simultaneous access to all bits in a word. An automatic power down feature permits the on-chip circuitry to enter a very low standby mode and be brought back into operation at a speed equal to the address access time.

A Low Power version with 2V Data Retention (EDI88128LPS) is also available for battery back-up operation. Military product is available compliant to MIL-PRF-38535.

* 15ns access time is advanced information, contact factory for availability.

This product is subject to change without notice.

FIGURE 1 – PIN CONFIGURATION

**32 DIP
32 SOJ
32 LCC
32 FLATPACK
TOP VIEW**

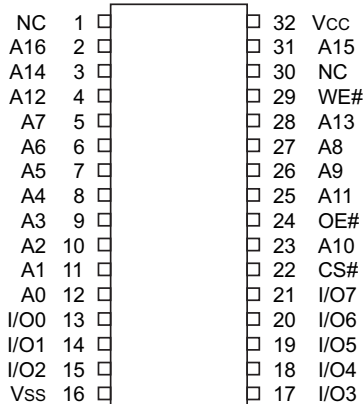

**32 ZIP
TOP VIEW**

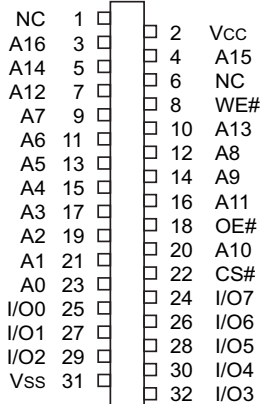

PIN DESCRIPTION

I/O0-7	Data Inputs/Outputs
A0-16	Address Inputs
WE#	Write Enable
CS#	Chip Select
OE#	Output Enable
VCC	Power (+5V ±10%)
VSS	Ground
NC	Not Connected

BLOCK DIAGRAM

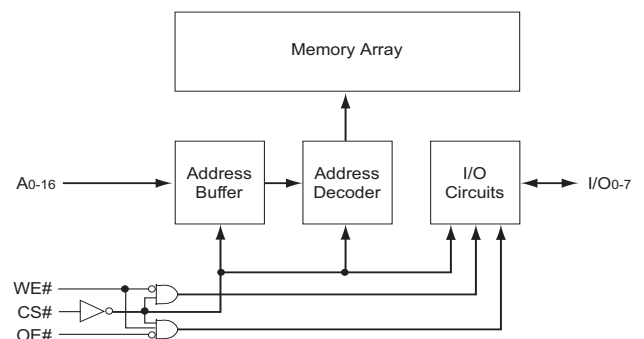



ABSOLUTE MAXIMUM RATINGS

Parameter		Unit
Voltage on any pin relative to V _{SS}	-0.5 to 7.0	V
Operating Temperature T _A (Ambient)		
Commercial	0 to +70	°C
Industrial	-40 to +85	°C
Military	-55 to +125	°C
Storage Temperature, Plastic	-65 to +150	°C
Power Dissipation	1.5	W
Output Current	20	mA
Junction Temperature, T _J	175	°C

NOTE:

Stress greater than those listed under "Absolute Maximum Ratings" may cause permanent damage to the device. This is a stress rating only and functional operation of the device at these or any other conditions greater than those indicated in the operational sections of this specification is not implied. Exposure to absolute maximum rating conditions for extended periods may affect reliability.

TRUTH TABLE

OE#	CS#	WE#	Mode	Output	Power
X	H	X	Standby	High Z	I _{CC2} , I _{CC3}
H	L	H	Output Deselect	High Z	I _{CC1}
L	L	H	Read	Data Out	I _{CC1}
X	L	L	Write	Data In	I _{CC1}

Recommended Operating Conditions

Parameter	Symbol	Min	Typ	Max	Unit
Supply Voltage	V _{CC}	4.5	5.0	5.5	V
Supply Voltage	V _{SS}	0	0	0	V
Input High Voltage	V _{IH}	2.2	—	V _{CC} +0.5	V
Input Low Voltage	V _{IL}	-0.3	—	+0.8	V

CAPACITANCE

T_A = +25°C

Parameter	Symbol	Condition	Max		Unit
			LLC	CSOJ, ZIP, DIP, Flatpack	
Address Lines	C _I	V _{IN} = V _{CC} or V _{SS} , f = 1.0MHz	12		pF
Data Lines	C _O	V _{OUT} = V _{CC} or V _{SS} , f = 1.0MHz	14		pF

These parameters are sampled, not 100% tested.

DC CHARACTERISTICS

V_{CC} = 5.0V, -55°C ≤ T_A ≤ +125°C

Parameter	Symbol	Conditions	Min	Typ	Max	Units	
Input Leakage Current	I _{LI}	V _{IN} = 0V to V _{CC}	—	—	±5	µA	
Output Leakage Current	I _{LO}	V _{I/O} = 0V to V _{CC}	—	—	±10	µA	
Operating Power Supply Current	I _{CC1}	WE#, CS# = V _{IL} , I _{I/O} = 0mA, CS2 = V _{IH}	(15-17ns)	—	300	mA	
			(20ns)	—	225	mA	
			(25-55ns)	—	200	mA	
Standby (TTL) Power Supply Current	I _{CC2}	CS# ≥ V _{IH} , V _{IN} ≤ V _{IH} or ≥ V _{IL}	(17-55ns)	—	25	mA	
			(15ns)	—	60	mA	
Full Standby Power Supply Current	I _{CC3}	CS# ≥ V _{CC} -0.2V V _{IN} ≥ V _{CC} -0.2V or V _{IN} ≤ 0.2V	CS (17-55ns)	—	3	mA	
			CS (15ns)	—	—	15	mA
			LPS	—	—	5	mA
Output Low Voltage	V _{OL}	I _{OL} = 8.0mA	—	—	0.4	V	
Output High Voltage	V _{OH}	I _{OH} = -4.0mA	2.4	—	—	V	

NOTE: DC test conditions : V_{IL} = 0.3V, V_{IH} = V_{CC} -0.3V



AC CHARACTERISTICS – READ CYCLE (15 to 20ns)

V_{CC} = 5.0V, V_{SS} = 0V, -55°C ≤ T_A ≤ +125°C

Parameter	Symbol		15ns*		17ns		20ns		Units
	JEDEC	Alt.	Min	Max	Min	Max	Min	Max	
Read Cycle Time	t _{AVAV}	t _{RC}	15		17		20		ns
Address Access Time	t _{AVQV}	t _{AA}		15		17		20	ns
Chip Enable Access Time	t _{ELQV}	t _{ACS}		15		17		20	ns
Chip Enable to Output in Low Z (1)	t _{ELQX}	t _{CLZ}	3		3		3		ns
Chip Disable to Output in High Z (1)	t _{EHQZ}	t _{CHZ}		8		8		10	ns
Output Hold from Address Change	t _{AVQX}	t _{OH}	0		0		0		ns
Output Enable to Output Valid	t _{GLQV}	t _{OE}		6		6		8	ns
Output Enable to Output in Low Z (1)	t _{GLQX}	t _{OLZ}	0		0		0		ns
Output Disable to Output in High Z(1)	t _{GHQZ}	t _{OHZ}		6		6		8	ns
Chip Enable to Power Up (1)	t _{ELICCH}	t _{PU}	0		0		0		ns
Chip Enable to Power Down (1)	t _{EHICCL}	t _{PD}		15		17		20	ns

1. This parameter is guaranteed by design but not tested.

AC CHARACTERISTICS – READ CYCLE (25 to 55ns)

V_{CC} = 5.0V, V_{SS} = 0V, -55°C ≤ T_A ≤ +125°C

Parameter	Symbol		25ns		35ns		45ns		55ns		Units
	JEDEC	Alt.	Min	Max	Min	Max	Min	Max	Min	Max	
Read Cycle Time	t _{AVAV}	t _{RC}	25		35		45		55		ns
Address Access Time	t _{AVQV}	t _{AA}		25		35		45		55	ns
Chip Enable Access Time	t _{ELQV}	t _{ACS}		25		35		45		55	ns
Chip Enable to Output in Low Z (1)	t _{ELQX}	t _{CLZ}	3		3		3		3		ns
Chip Disable to Output in High Z (1)	t _{EHQZ}	t _{CHZ}		12		20		20		20	ns
Output Hold from Address Change	t _{AVQX}	t _{OH}	0		0		0		0		ns
Output Enable to Output Valid	t _{GLQV}	t _{OE}		10		15		20		25	ns
Output Enable to Output in Low Z (1)	t _{GLQX}	t _{OLZ}	0		0		0		0		ns
Output Disable to Output in High Z(1)	t _{GHQZ}	t _{OHZ}		10		15		20		20	ns
Chip Enable to Power Up (1)	t _{ELICCH}	t _{PU}	0		0		0		0		ns
Chip Enable to Power Down (1)	t _{EHICCL}	t _{PD}		25		35		45		55	ns

1. This parameter is guaranteed by design but not tested.

AC TEST CONDITIONS

Figure 1

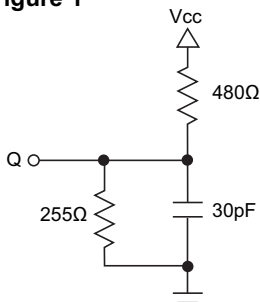
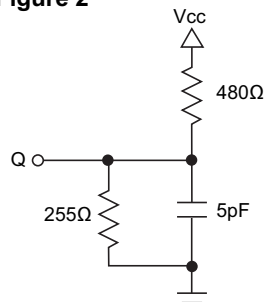

Figure 2



Input Pulse Levels	V _{SS} to 3.0V
Input Rise and Fall Times	5ns
Input and Output Timing Levels	1.5V
Output Load	Figure 1

NOTE: For t_{EHQZ}, t_{GHQZ} and t_{WLQZ}, CL = 5pF Figure 2



AC CHARACTERISTICS – WRITE CYCLE (15 to 20ns)

V_{CC} = 5.0V, V_{SS} = 0V, -55°C ≤ T_A ≤ +125°C

Parameter	Symbol		15ns*		17ns		20ns		Units
	JEDEC	Alt.	Min	Max	Min	Max	Min	Max	
Write Cycle Time	t _{AVAV}	t _{WC}	15		17		20		ns
Chip Enable to End of Write	t _{ELWH}	t _{CW}	12		13		15		ns
	t _{ELEH}	t _{CW}	12		13		15		ns
Address Setup Time	t _{AVWL}	t _{AS}	0		0		0		ns
	t _{AVEL}	t _{AS}	0		0		0		ns
Address Valid to End of Write	t _{AVWH}	t _{AW}	12		13		15		ns
	t _{AVEH}	t _{AW}	12		13		15		ns
Write Pulse Width	t _{WLWH}	t _{WP}	12		13		15		ns
	t _{WLEH}	t _{WP}	12		13		15		ns
Write Recovery Time	t _{WHAX}	t _{WR}	0		0		0		ns
	t _{EHAX}	t _{WR}	0		0		0		ns
Data Hold Time	t _{WHDX}	t _{DH}	0		0		0		ns
	t _{EHDX}	t _{DH}	0		0		0		ns
Write to Output in High Z (1)	t _{WLQZ}	t _{WHZ}	0	7	0	8	0	8	ns
Data to Write Time	t _{DVWH}	t _{DW}	7		8		10		ns
	t _{DVEH}	t _{DW}	7		8		10		ns
Output Active from End of Write (1)	t _{WHQX}	t _{WLZ}	3		3		3		ns

1. This parameter is guaranteed by design but not tested.

AC CHARACTERISTICS – WRITE CYCLE (25 to 55ns)

V_{CC} = 5.0V, V_{SS} = 0V, -55°C ≤ T_A ≤ +125°C

Parameter	Symbol		25ns		35ns		45ns		55ns		Units
	JEDEC	Alt.	Min	Max	Min	Max	Min	Max	Min	Max	
Write Cycle Time	t _{AVAV}	t _{WC}	25		35		45		55		ns
Chip Enable to End of Write	t _{E1LWH}	t _{CW}	20		25		35		45		ns
	t _{ELEH}	t _{CW}	20		25		35		45		ns
Address Setup Time	t _{AVWL}	t _{AS}	0		0		0		0		ns
	t _{AVEL}	t _{AS}	0		0		0		0		ns
Address Valid to End of Write	t _{AVWH}	t _{AW}	20		25		35		45		ns
	t _{AVEH}	t _{AW}	20		25		35		45		ns
Write Pulse Width	t _{WLWH}	t _{WP}	20		30		30		35		ns
	t _{WLEH}	t _{WP}	20		30		30		35		ns
Write Recovery Time	t _{WHAX}	t _{WR}	0		0		5		5		ns
	t _{EHAX}	t _{WR}	0		0		5		5		ns
Data Hold Time	t _{WHDX}	t _{DH}	0		0		0		0		ns
	t _{EHDX}	t _{DH}	0		0		0		0		ns
Write to Output in High Z (1)	t _{WLQZ}	t _{WHZ}	0	10	0	13	0	15	0	20	ns
Data to Write Time	t _{DVWH}	t _{DW}	15		20		20		25		ns
	t _{DVEH}	t _{DW}	15		20		20		25		ns
Output Active from End of Write (1)	t _{WHQX}	t _{WLZ}	3		3		3		3		ns

1. This parameter is guaranteed by design but not tested.



FIGURE 2 – TIMING WAVEFORM - READ CYCLE

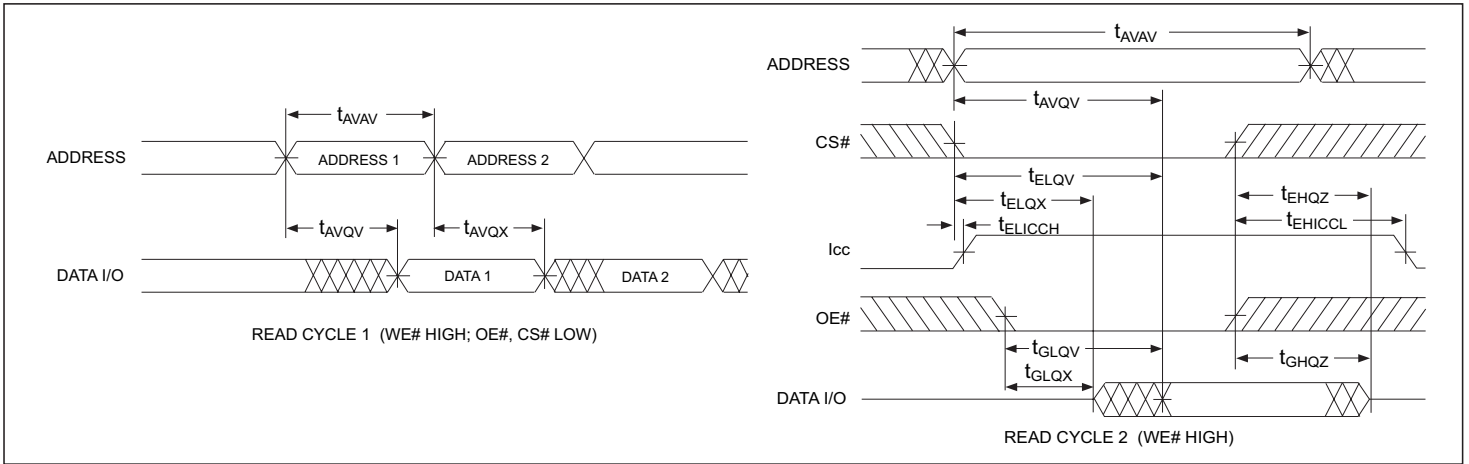

FIGURE 3 – WRITE CYCLE - WE# CONTROLLED

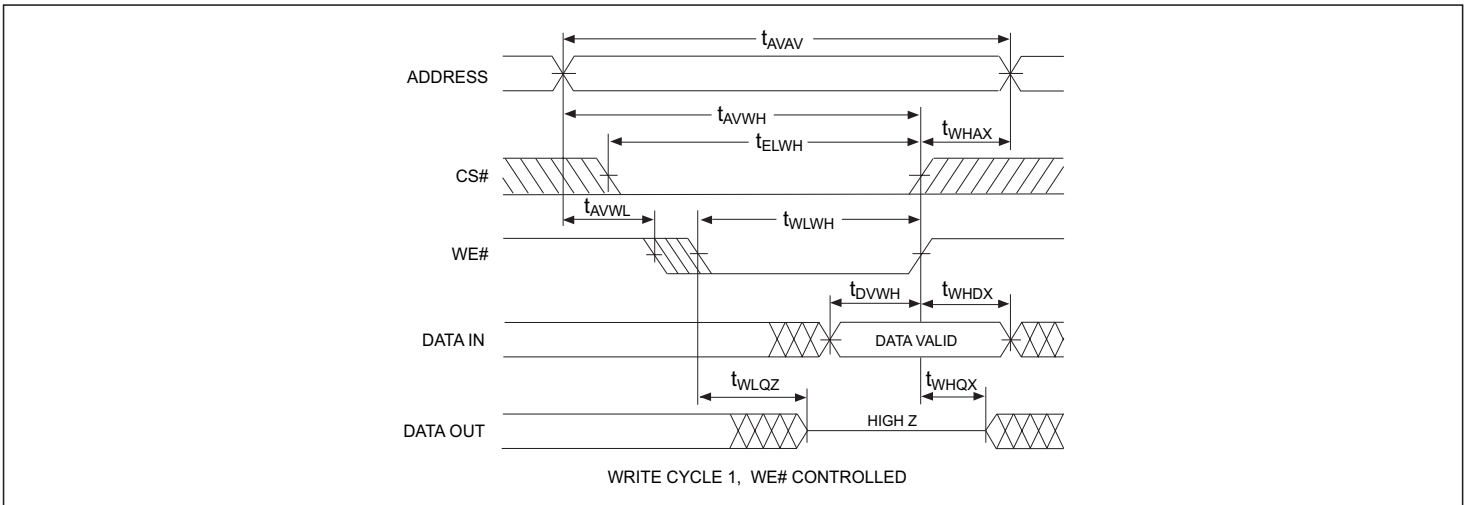
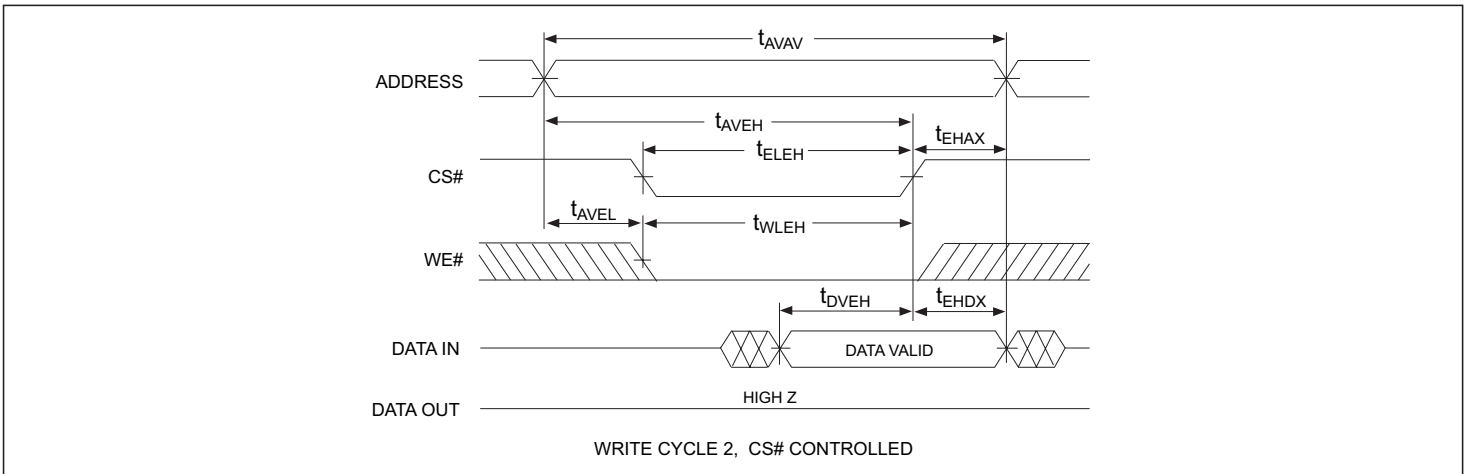

FIGURE 4 – WRITE CYCLE - CS# CONTROLLED





DATA RETENTION CHARACTERISTICS (EDI88128LPA only)

-55°C ≤ TA ≤ +125°C

Characteristic Low Power Version only	Sym	Conditions	Min	Typ	Max	Units
Data Retention Voltage	V _{CC}	V _{CC} = 2.0V	2	-	-	V
Data Retention Quiescent Current	I _{CCDR}	CS# ≥ V _{CC} - 0.2V	-	0.5	2	mA
Chip Disable to Data Retention Time (1)	T _{CDR}	V _{IN} ≥ V _{CC} - 0.2V	0	-	-	ns
Operation Recovery Time (1)	T _R	or V _{IN} ≤ 0.2V	T _{AVAV} *	-	-	ns

NOTE:

1. Parameter guaranteed by design, but not tested.

* Read Cycle Time

FIGURE 5 – DATA RETENTION - CS# CONTROLLED

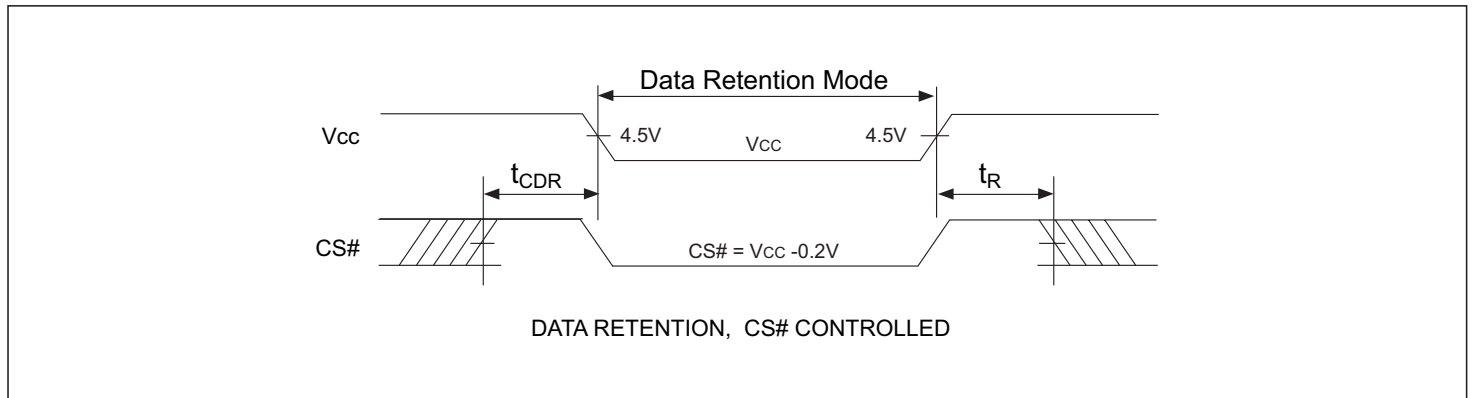



PACKAGE 9: 32 PIN SIDEBRAZED CERAMIC DIP (600mils wide)

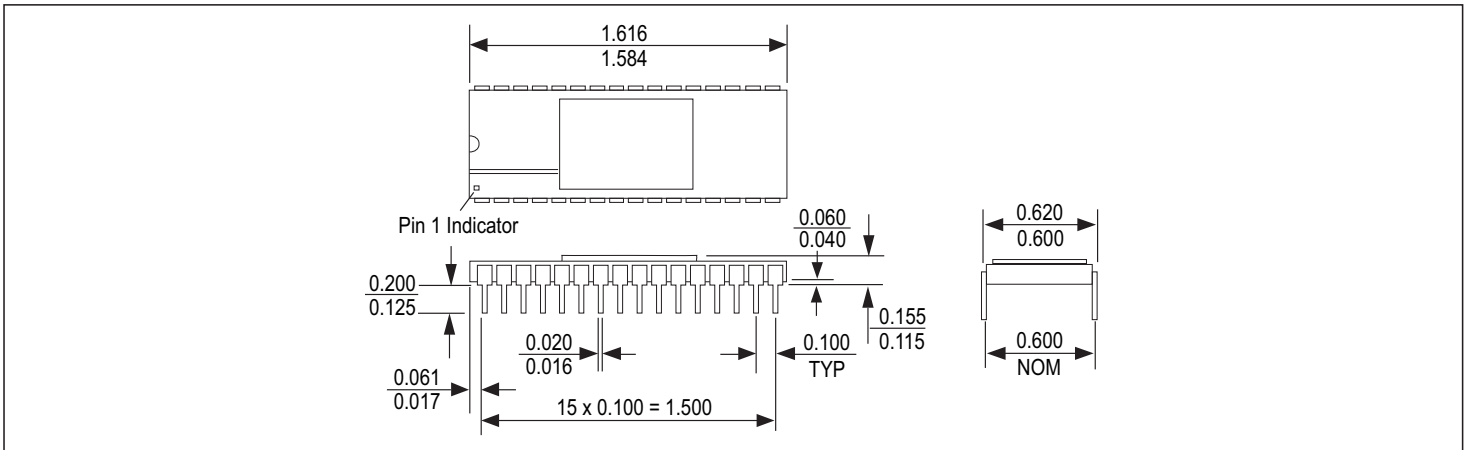

ALL DIMENSIONS ARE IN INCHES

PACKAGE 100: 32 LEAD CERAMIC ZIP

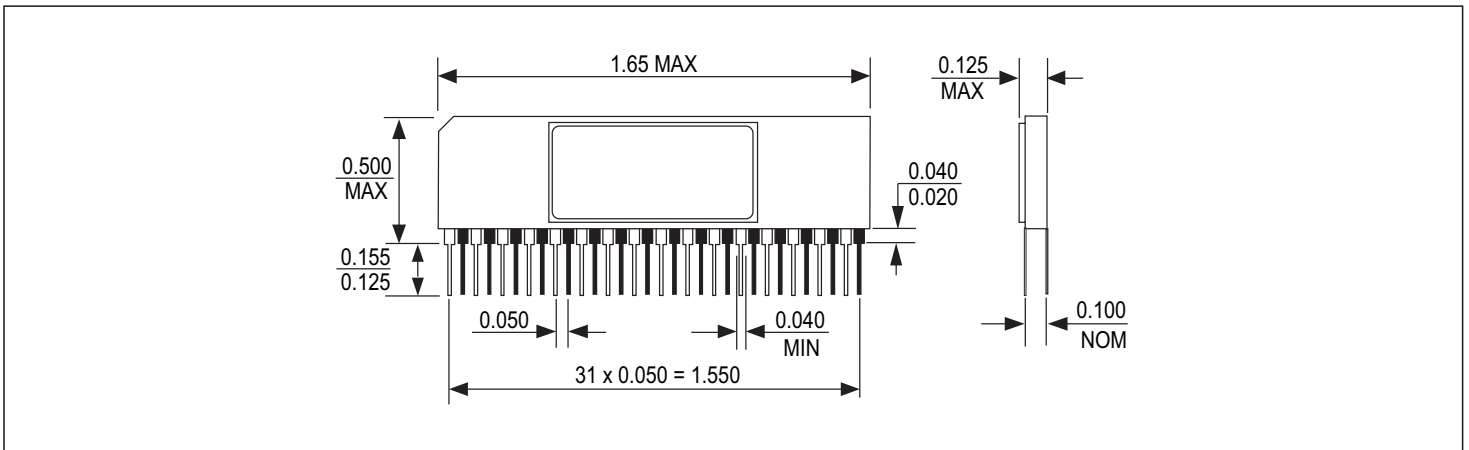

ALL DIMENSIONS ARE IN INCHES

PACKAGE 102: 32 PIN SIDEBRAZED CERAMIC DIP (400mils wide)

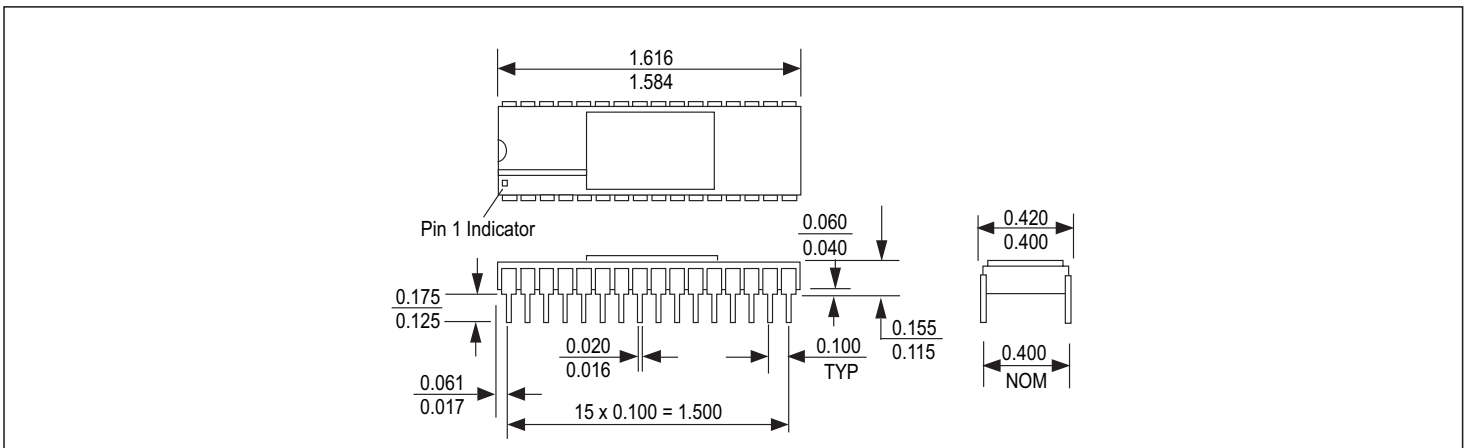

ALL DIMENSIONS ARE IN INCHES



PACKAGE 140: 32 LEAD CERAMIC SOJ

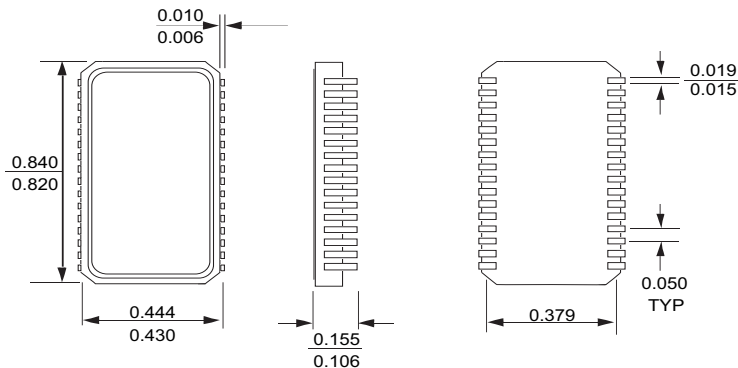

ALL DIMENSIONS ARE IN INCHES

PACKAGE 141: 32 PAD CERAMIC LCC

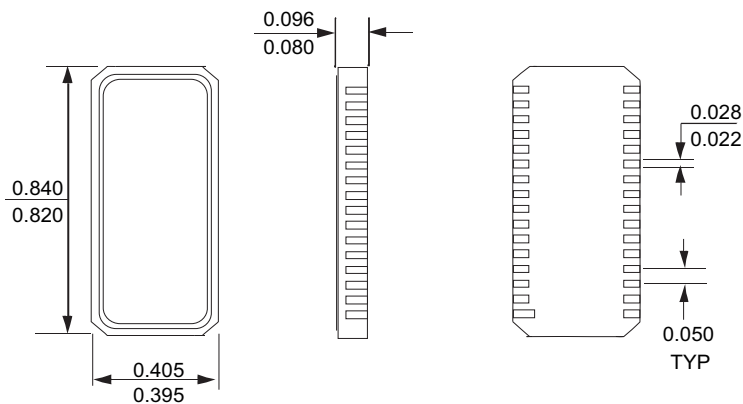

ALL DIMENSIONS ARE IN INCHES

PACKAGE 142: 32 PIN CERAMIC FLATPACK

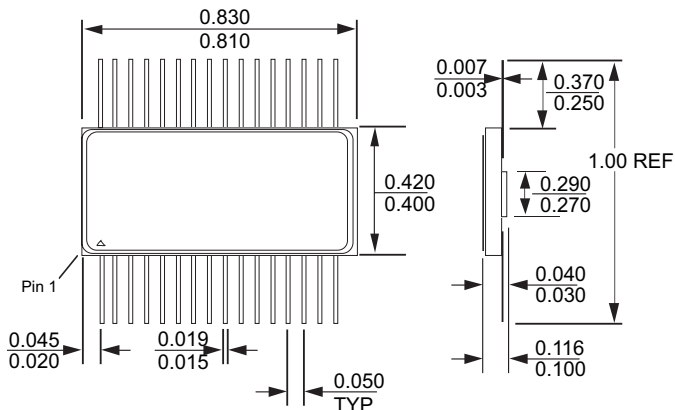

ALL DIMENSIONS ARE IN INCHES



ORDERING INFORMATION

EDI 8 8 128 CS X X X

WHITE ELECTRONIC DESIGNS

SRAM

ORGANIZATION, 128Kx8

TECHNOLOGY:

CS = CMOS Standard Power

LPS = Low Power

ACCESS TIME (ns)

PACKAGE TYPE:

C = 32 lead Sidebrazed DIP, 600 mil (Package 9)

F = 32 lead Ceramic Flatpack (Package 142)

L = 32 pad Ceramic LCC (Package 141)

N = 32 lead Ceramic SOJ (Package 140)

T = 32 lead Sidebrazed DIP, 400 mil (Package 102)

Z = 32 lead Ceramic ZIP (Package 100)

DEVICE GRADE:

B = MIL-STD-883 Compliant

M = Military Screened -55°C to +125°C

I = Industrial -40°C to +85°C

C = Commercial 0°C to +70°C