

GSD

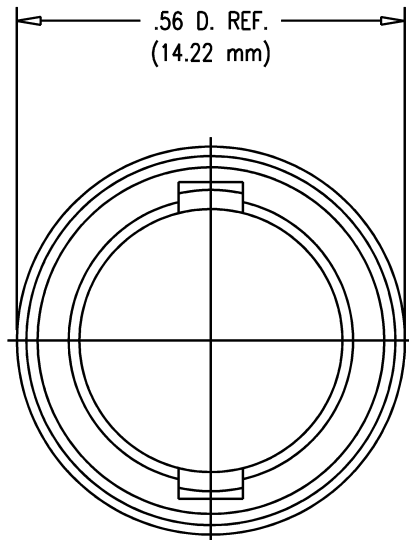
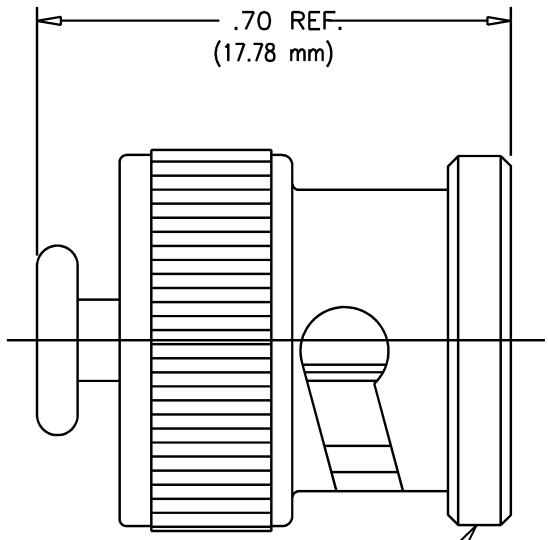

STAMP: PER TABLE

NOTES:

1. MATERIALS:
ALL METAL PARTS - BRASS, QQ-B-626
PAD - SILICON RUBBER, ZZ-R-765
2. FINISHES:
ALL METAL PARTS - SILVER PLATE PER QQ-S-365 THEN PRIME PER MIL-F-14072, TYPE 1 AND PAINT ONE COAT OF OLIVE GREEN #X24087 SEMI-GLOSS ENAMEL PER SPEC TT-E-529.

MARKING TABLE

-1	91836	SM-C-447403 B YRWK (DATE CODE)
-2	KINGS	758-36-101 YRWK (DATECODE)
-4	KINGS	KC-89-59 YRWK (DATECODE)

GSD

C-89-59-*	
REVISIONS	
ISSUE	CHANGES
12	CN 38298 E REDRAWN TML 04/24/01
13	CN 38917 E DCT 8/25/3
14	CN 39164 C DCT 8/23/5
15	CN 39491 E DRK 06/14/06
SCALE 4:1	
APPROX SURFACE AREA	
USED ON	
REF:	
CAP SUB-ASS'Y	
DRAWN JEP	DATE 08/11/83
DESIGN GL	DATE 08/11/83
APPR.	DATE
 KINGS ELECTRONICS CO., INC. ROCK HILL, SOUTH CAROLINA 29730	
C-89-59-*	