

Common Mode Inductors

EE Style

Designed to prevent noise emission in switching power supplies at input.

Windings balanced to 1%

Isolation 2500 V_{RMS}

"EE" Part Number	L ⁽¹⁾ Min. (mH)	DCR Max. (mΩ)	I ⁽²⁾ Max. (A)	L _L typ. (μH)	Size Code	SRF KHz
L-14000	4.40	49	5.50	45	A	575
L-14001	6.90	77	4.40	70	A	492
L-14002	10.90	122	3.50	125	A	385
L-14003	17.80	196	2.70	180	A	273
L-14004	28.60	316	2.20	300	A	222
L-14005	43.60	489	1.75	440	A	153
L-14006	70.30	785	1.38	720	A	161
L-14007	111.60	1240	1.10	1100	A	110
L-14008	176.10	1980	0.09	1800	A	101
L-14009	1.05	50	2.50	9	B	1443
L-14010	2.37	80	2.00	14	B	1110
L-14011	3.80	127	1.60	25	B	805
L-14012	6.00	202	1.28	36	B	630
L-14013	9.80	319	1.00	60	B	424
L-14014	16.00	500	0.80	90	B	391
L-14015	27.70	820	0.63	144	B	289
L-14016	40.50	1260	0.50	240	B	250
L-14017	63.50	2020	0.40	360	B	190

EE Style Schematics

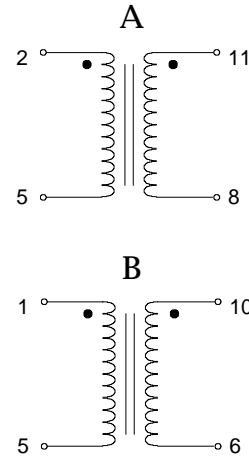

Test Conditions

1. Tested at 10 kHz & 100mV
2. 40°C temperature rise

Size "A" - EE 12 Pin
(Unused Pins Removed)

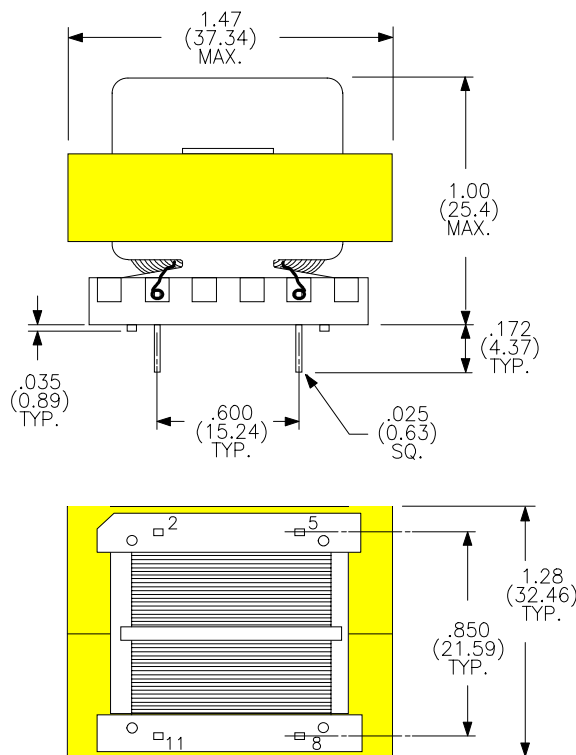

Physical Dimensions
in inches (mm)

Size "B" - EE 10 Pin
(Unused Pins Removed)

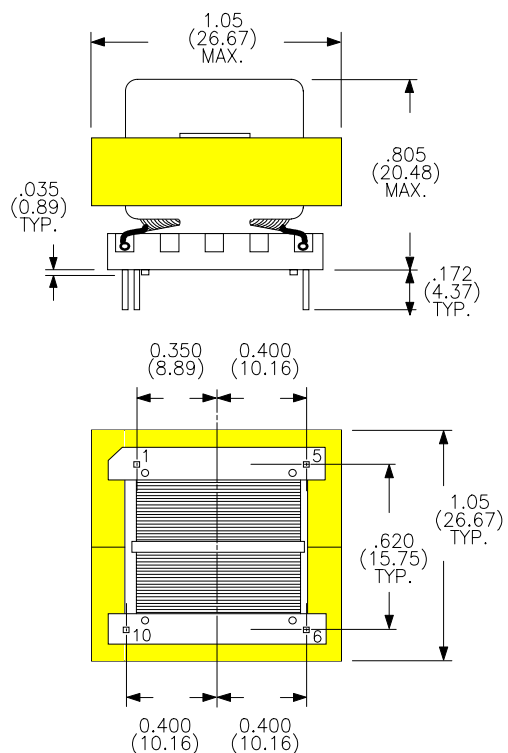

Specifications are subject to change without notice

CMODE-EE 4/97

Common Mode Inductors

EE Style

Designed to prevent noise emission in switching power supplies at input.

Windings balanced to 1%

Isolation 2500 V_{RMS}

NEW SMALLER SIZE! "C"

"EE" Part Number	L ⁽¹⁾ Min. (mH)	DCR Max. (mΩ)	I ⁽²⁾ Max. (A)	L _L typ. (μH)	Size Code	SRF kHz
L-16004	0.100	25	2.80	6	C	6043
L-16005	0.120	28	2.80	7	C	5400
L-16006	0.150	30	2.80	8	C	4807
L-16007	0.180	38	2.20	8	C	4437
L-16008	0.220	44	2.20	9	C	3970
L-16009	0.270	51	2.20	10	C	3729
L-16010	0.330	58	1.70	11	C	2260
L-16011	0.470	78	1.40	16	C	3037
L-16012	0.560	91	1.40	18	C	2672
L-16013	0.680	115	1.10	20	C	2246
L-16014	0.820	131	1.10	25	C	2000
L-16015	1.000	194	0.88	35	C	1865
L-16016	1.200	219	0.88	47	C	1523
L-16017	1.500	278	0.70	49	C	1225
L-16018	1.800	306	0.70	59	C	1044
L-16019	2.200	431	0.55	76	C	1100
L-16020	2.700	469	0.55	91	C	950
L-16021	3.300	531	0.55	101	C	770
L-16022	3.900	669	0.44	135	C	765
L-16023	4.700	760	0.44	158	C	687
L-16024	5.600	853	0.44	196	C	625
L-16025	6.800	1240	0.35	257	C	569
L-16026	8.200	1400	0.35	296	C	485
L-16027	10.000	1610	0.35	362	C	372
L-16028	12.000	1980	0.27	410	C	367
L-16029	15.000	2240	0.27	503	C	345
L-16030	18.000	2450	0.27	602	C	301
L-16031	22.000	3490	0.22	730	C	217
L-16032	27.000	4600	0.17	870	C	208
L-16033	33.000	5210	0.17	1150	C	216
L-16034	39.000	7190	0.13	1300	C	202
L-16035	47.000	7800	0.13	1541	C	179
L-16036	56.000	8690	0.13	1875	C	175

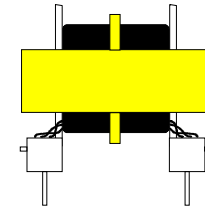

EE Style Schematics

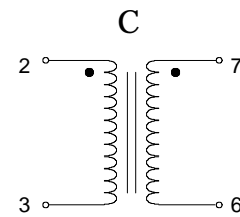

Size "C" - EE 8 Pin
(Unused Pins Removed)

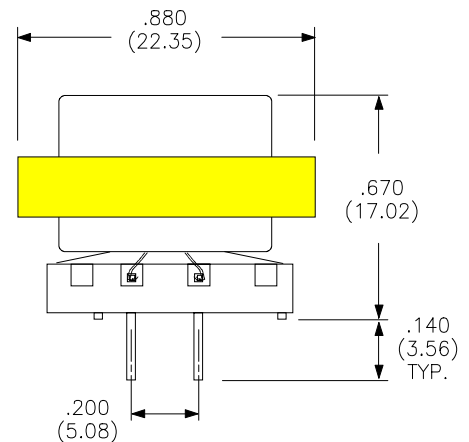

Physical Dimensions
in inches (mm)

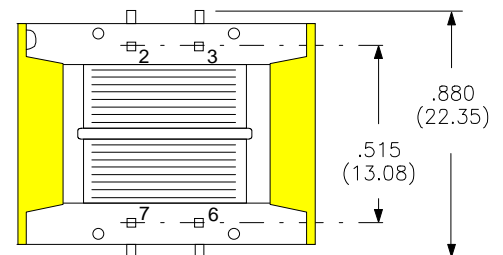

Test Conditions

1. Tested at 10 kHz & 100mV
2. 40°C temperature rise

Specifications are subject to change without notice

CMODE-EE 4/97