

Features

- Ideal for 802.11b/g
- +26 dBm P1dB Typical at 3.3 V
- 29.5 dB Gain Typical
- 802.11b compliant to 23 dBm P_{OUT}
- 802.11g compliant to 19 dBm P_{OUT}
- Micro-Amp Shutdown
- Integrated Detector
- SiGe Process: Lowest Cost Solution
- Operates from 1.5 V to 4.0 V
- Lead-Free 3 mm 12-Lead PQFN Package
- 100% Matte Tin Plating over Copper
- Halogen-Free "Green" Mold Compound
- RoHS* Compliant 260°C Reflow Compatible

Description

The MAAPSS0075 is a three stage power amplifier, designed for 2.4 GHz linear applications. This power amplifier is available in a lead free 3 mm 12-lead PQFN plastic package. The MAAPSS0075 also features an integrated power detector.

Ordering Information¹

Part Number	Package
MAAPSS0075TR	1000 piece reel
MAAPSS0075TR-3000	3000 piece reel
MAAPSS0075SMB	Sample Test Board (Includes 5 Samples)

1. Reference Application Note M513 for reel size information.

Functional Schematic

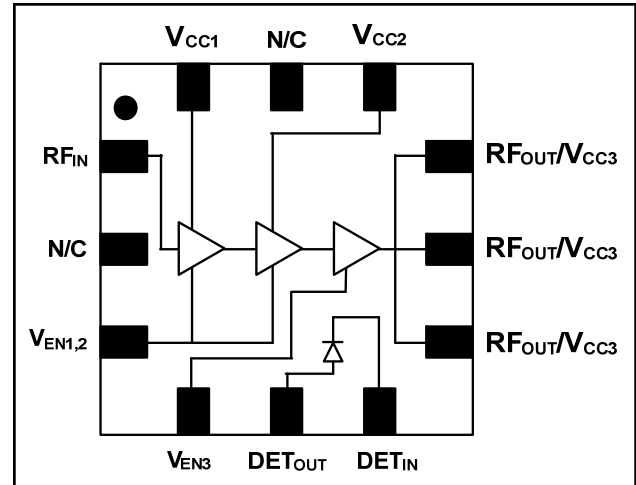

Pin Configuration

Pin No.	Pin Name	Description
1	RF _{IN}	RF Input
2	N/C	No Connect
3	V _{EN1,2}	Power Enable
4	V _{EN3}	Power Enable
5	DET _{OUT}	Detector Output
6	DET _{IN}	Detector Input
7	RF _{OUT} / V _{CC3}	RF Output, 3rd Stage Supply
8	RF _{OUT} / V _{CC3}	RF Output, 3rd Stage Supply
9	RF _{OUT} / V _{CC3}	RF Output, 3rd Stage Supply
10	V _{CC2}	2nd Stage Supply
11	N/C	No Connect
12	V _{CC1}	1st Stage Supply
Pad	Paddle ²	RF & DC Ground

2. The exposed pad centered on the package bottom must be connected to RF and DC ground.

* Restrictions on Hazardous Substances, European Union Directive 2002/95/EC.

Electrical Specifications: F = 2.4 GHz, V_{CC} = 3.3 V, V_{EN} = 3.0 V, T_A = 25°C, Z₀ = 50 Ω

Parameter	Test Conditions	Units	Min.	Typ.	Max
Gain		dB	27.5	29.5	31.5
Input VSWR		:1		1.6	
Forward Isolation		dB		40	
P1dB		dBm		26	
Supply Voltage	V _{CC1} , V _{CC2} , V _{CC3}	V		3.3	
Bias Voltage	V _{EN}	V		3	
Current	Idle P _{OUT} = 19 dBm P _{OUT} = 23 dBm	mA mA mA		100 185 275	150 220 300
Off Current	V _{EN} = 0 V	μA		3	20
Control Current	V _{EN} Current	mA		3	
Harmonics	2fo 3fo	dBc dBc		-37 -52	
Duty Cycle		%		100	
Linear Output Power	DSS source; compliance with 802.11b EVM=3.5%, OFDM, QAM-64, 54 Mbps	dBm dBm		23 19	
Detector Output	P _{OUT} = 19 dBm	mV		780	
Detector Sensitivity	Up to P _{OUT} = 19 dBm	mV/dB		70	
Stability	+1.8 V < V _{CC} < +3.6 V, VSWR < 6.0:1, -20°C < T _C < +85°C, RBW = 3 MHz max hold			All spurs < -60 dBc	
Ruggedness	+1.8V < V _{CC} < +3.6 V, P _{OUT} < +23 dBm, VSWR < 6:1			No permanent damage	

Absolute Maximum Ratings ^{3,4}

Parameter	Absolute Maximum
Input Power	+ 5 dBm
Operating Supply Voltage	+4.0 Volts
Operating Control Voltage	+3.0 Volts
Operating Temperature	-40°C to +85°C
Channel Temperature	+150°C
Storage Temperature	-40°C to +150°C

- Exceeding any one or combination of these limits may cause permanent damage to this device.
- M/A-COM does not recommend sustained operation near these survivability limits.

Operating the MAAPSS0075

The MAAPSS0075 is static sensitive. Please handle with care. To operate the device, follow these steps.

- Apply V_{CC} (3.3 V).
- Apply V_{EN} (3.0 V).
- Set Pin.
- Turn off in reverse order with V_{CC} last.

Evaluation Board Schematic

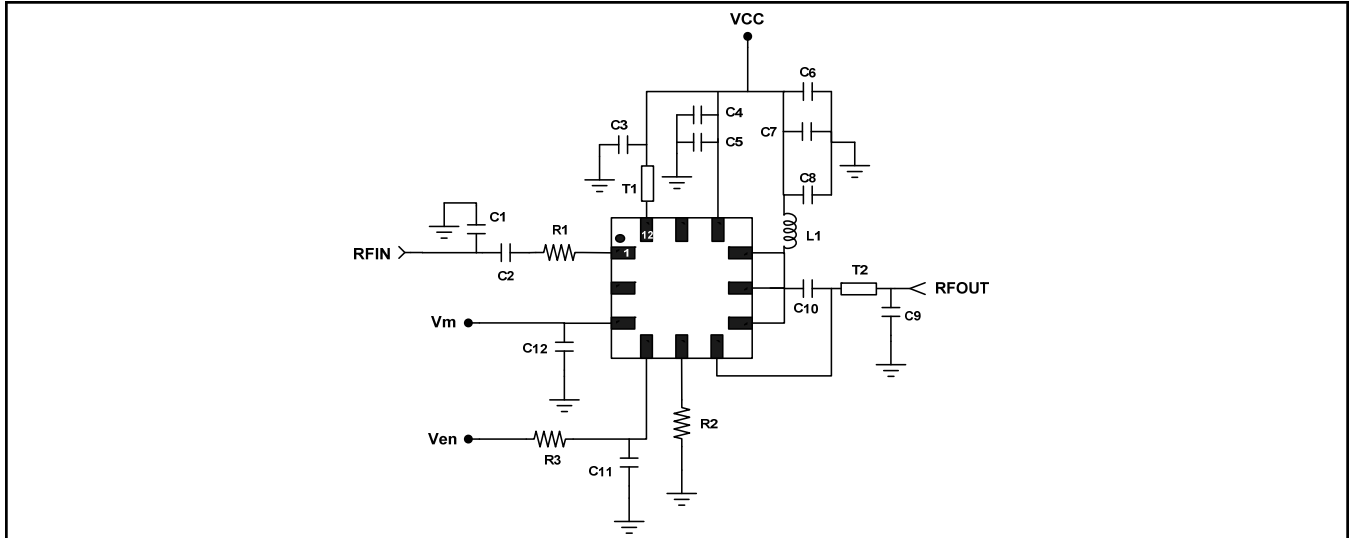

MAAPSS0075 External Parts List⁵

Designator	Value	Footprint	Manufacturer
C1, C9	1.5 pF	0402	Murata
C2	1000 pF	0402	Murata
C3, C4, C7, C11, C12	0.1 μ F	0402	Murata
C5, C8, C10	47 pF	0402	Murata
C6	10 μ F	1206	AVX
L1	10 nH	0402	Coilcraft
R1	10 Ω	0402	Panasonic
R2	100K Ω	0402	Panasonic
R3	619 Ω	0402	Panasonic

5. Equivalent components can be substituted.

Recommended PCB Configuration

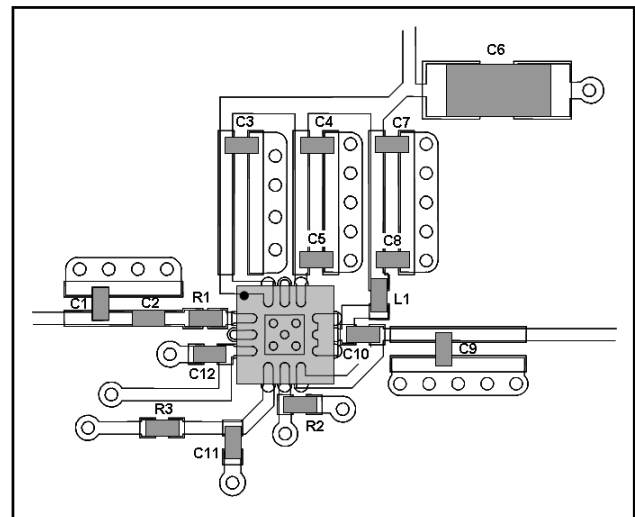

Transmission Line Dimensions, 0.20 mm thick FR4

Designator	Length (mil) *	Width (mil)
T1	190	15.0
T2	70	14.7

* From package edge to center of component

Typical Performance Curves: $V_{CC} = 3.3\text{ V}$, $V_{EN} = 3.0\text{ V}$, over Temperature

S11 vs. Frequency

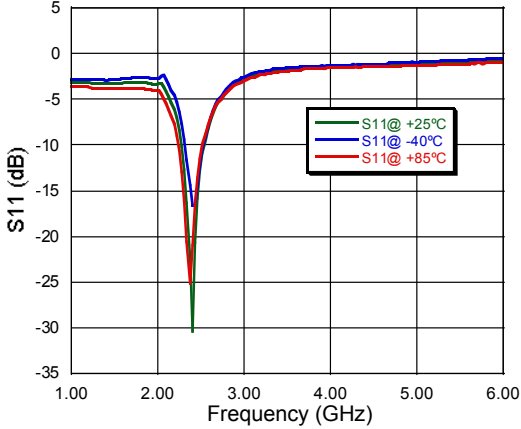

S11 vs. Frequency (2.4 GHz - 2.5 GHz)

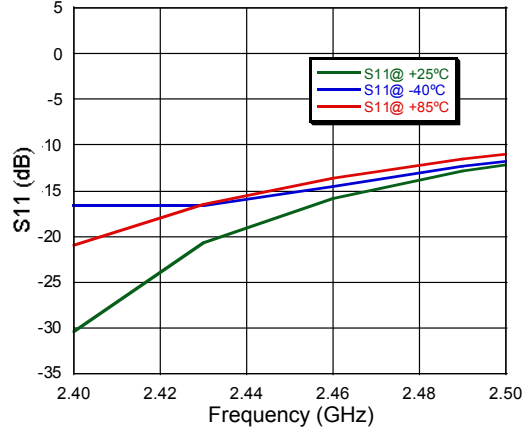

S21 vs. Frequency

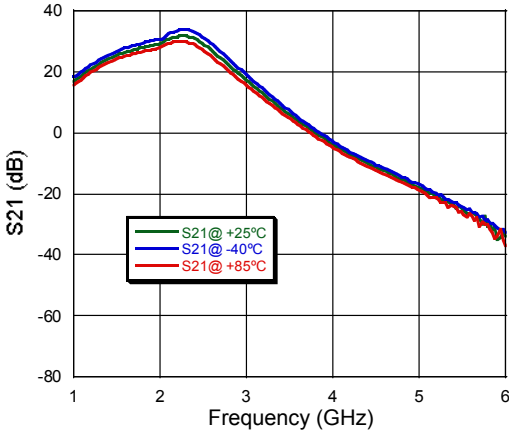

S21 vs. Frequency (2.4 GHz - 2.5 GHz)

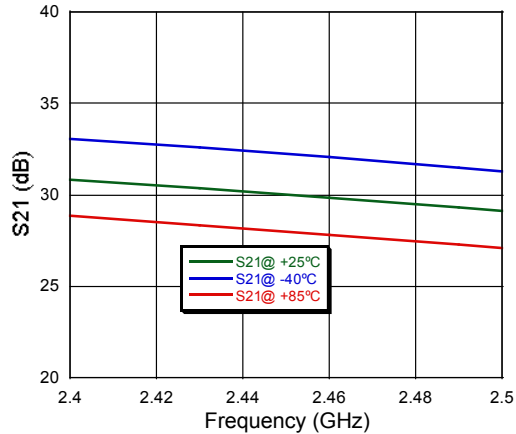

S22 vs. Frequency

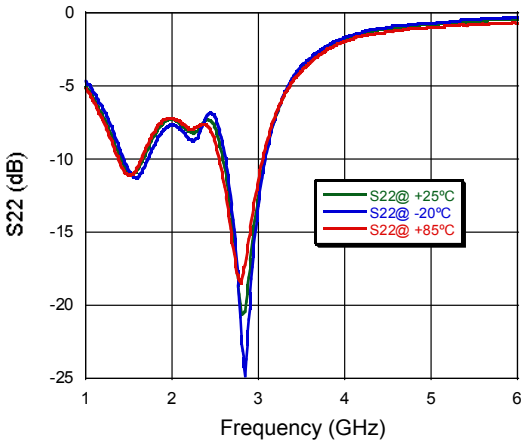

S22 vs. Frequency (2.4 GHz - 2.5 GHz)

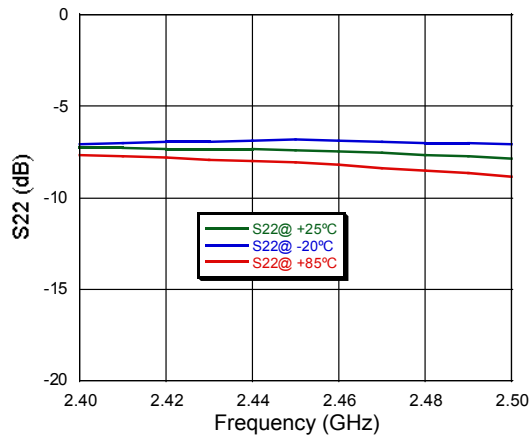

4

ADVANCED: Data Sheets contain information regarding a product M/A-COM Technology Solutions is considering for development. Performance is based on target specifications, simulated results, and/or prototype measurements. Commitment to develop is not guaranteed.
PRELIMINARY: Data Sheets contain information regarding a product M/A-COM Technology Solutions has under development. Performance is based on engineering tests. Specifications are typical. Mechanical outline has been fixed. Engineering samples and/or test data may be available. Commitment to produce in volume is not guaranteed.

- **North America** Tel: 800.366.2266 / Fax: 978.366.2266
- **Europe** Tel: 44.1908.574.200 / Fax: 44.1908.574.300
- **Asia/Pacific** Tel: 81.44.844.8296 / Fax: 81.44.844.8298

Visit www.macomtech.com for additional data sheets and product information.

M/A-COM Technology Solutions Inc. and its affiliates reserve the right to make changes to the product(s) or information contained herein without notice.

Typical Performance Curves: $V_{CC} = 3.3\text{ V}$, $V_{EN} = 3.0\text{ V}$

Spectral Mask for 802.11b, $P_{OUT} = 23\text{ dBm}$

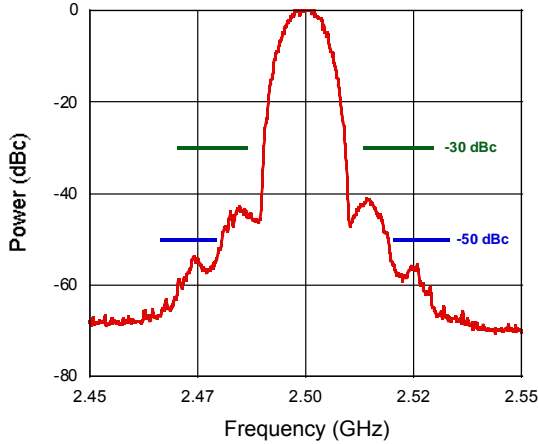

P_{1dB} at 2.45 GHz

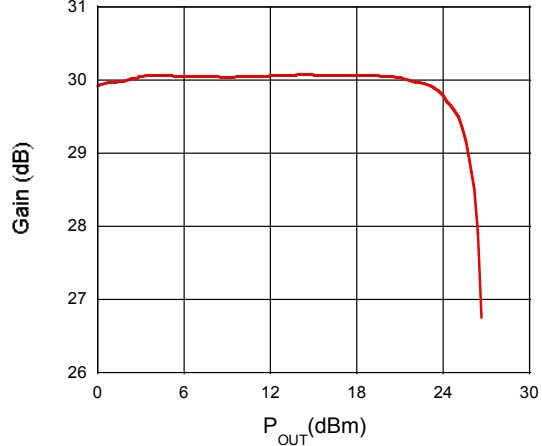

V_{DET} vs. P_{OUT} over Temperature at 2.45 GHz

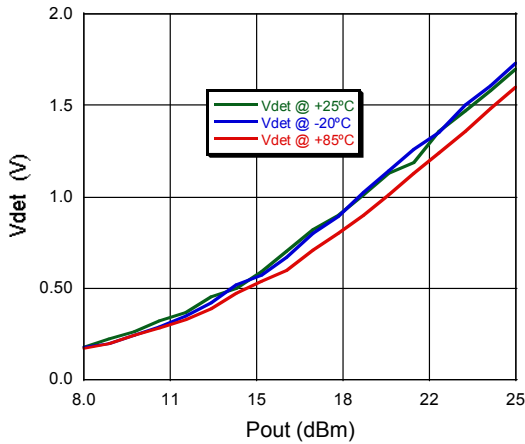

Harmonics vs. P_{IN} at 2.45 GHz

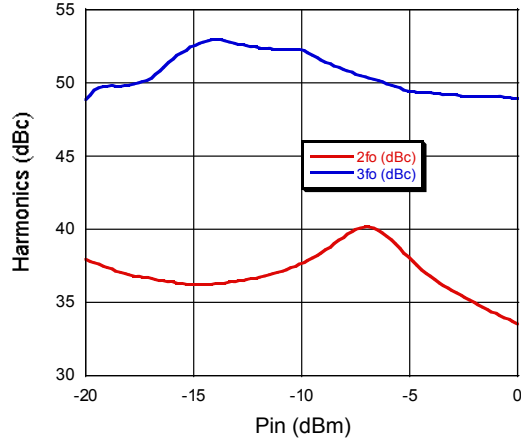

Current vs. P_{OUT} over Temperature at 2.45 GHz

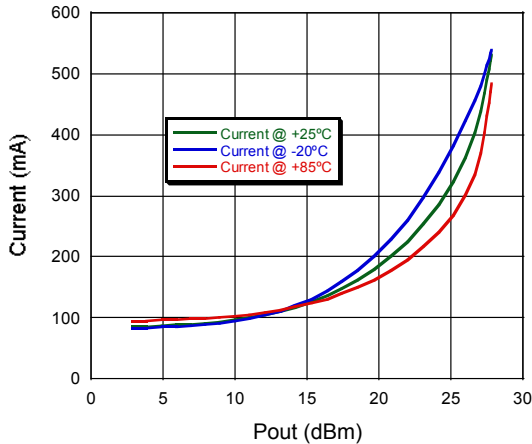

EVM vs. P_{OUT} , OFDM, QAM-64, 54 Mbps

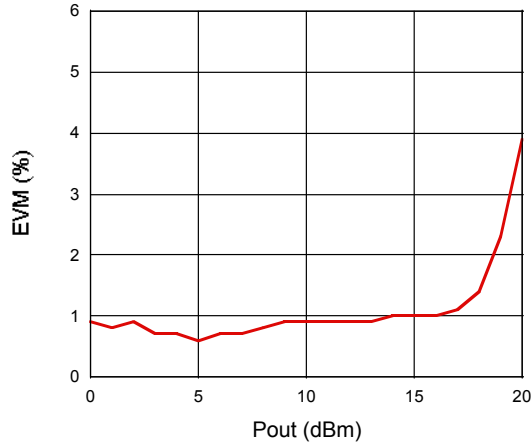

ADVANCED: Data Sheets contain information regarding a product M/A-COM Technology Solutions is considering for development. Performance is based on target specifications, simulated results, and/or prototype measurements. Commitment to develop is not guaranteed.
PRELIMINARY: Data Sheets contain information regarding a product M/A-COM Technology Solutions has under development. Performance is based on engineering tests. Specifications are typical. Mechanical outline has been fixed. Engineering samples and/or test data may be available. Commitment to produce in volume is not guaranteed.

- **North America** Tel: 800.366.2266 / Fax: 978.366.2266
 - **Europe** Tel: 44.1908.574.200 / Fax: 44.1908.574.300
 - **Asia/Pacific** Tel: 81.44.844.8296 / Fax: 81.44.844.8298
- Visit www.macomtech.com for additional data sheets and product information.

M/A-COM Technology Solutions Inc. and its affiliates reserve the right to make changes to the product(s) or information contained herein without notice.

Lead-Free 3 mm 12-Lead PQFN†

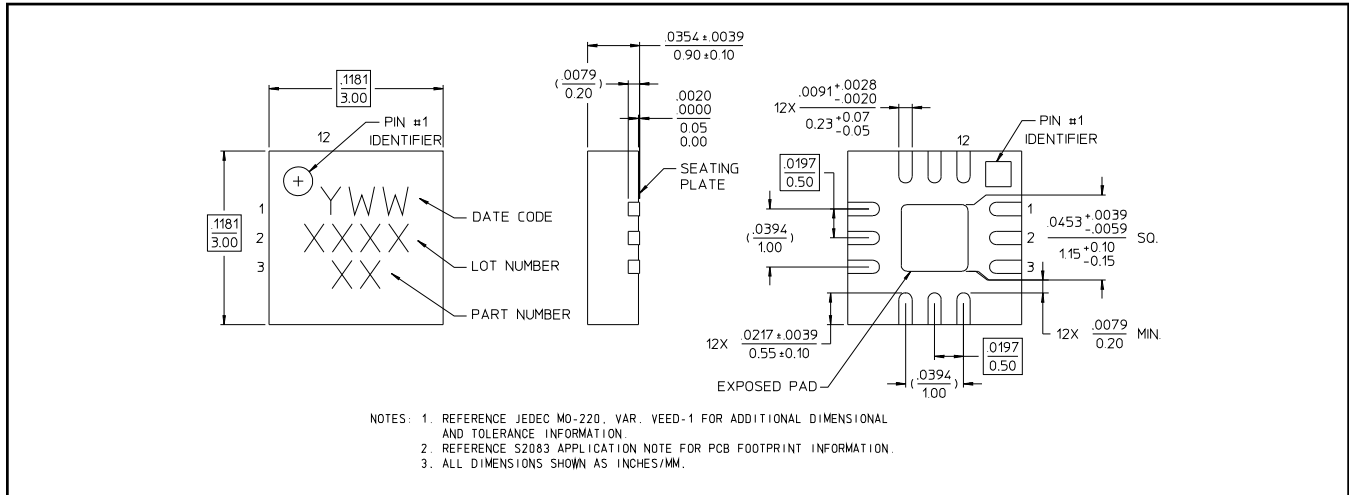

† Reference Application Note M538 for lead-free solder reflow recommendations.
Meets JEDEC moisture sensitivity level 1 requirements.