

### General Description

The AM4967 is a single-coil, single-phase motor pre-driver designed by bipolar process. Its rotation speed can be controlled through an external PWM. This IC requires few external components and has the merit of high efficiency which make it suitable for use in great air volume, large current and high voltage applications.

The AM4967 is available in SSOP-16 package.

### Features

- Single-phase Full-wave Pre-drive
- Rotation Speed Control via External PWM
- Maximum Operating Current Limit
- Linear Start Function for Reducing Large Current Impulse at the Moment of Turn-on
- Minimum Rotation Speed Setting
- Lock Protection and Auto Start Function
- Rotation Speed Indication
- Over Temperature Protection

### Application

- CPU and OA (Office Automation) Cooler Fan
- Brushless DC Motor



Figure 1. Package Type of AM4967

**Pin Configuration**

GS Package  
(SSOP-16)

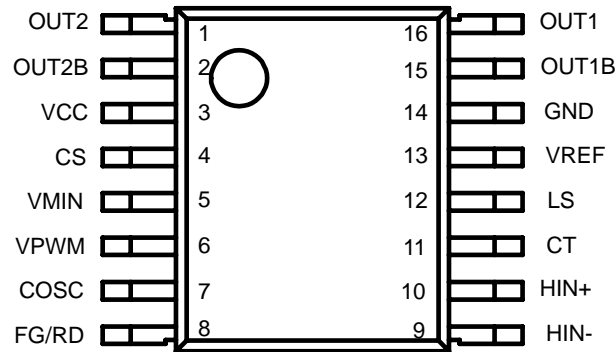

Figure 2. Pin Configuration of AM4967

**Pin Description**

Pin Number	Pin Name	Function
1	OUT2	Second channel P-type driver output. Open-drain output, must be connected with pull-up resistor to drive external power devices in operation
2	OUT2B	Second channel N-type driver output. Push-pull output to drive external power devices
3	VCC	Power supply
4	CS	Current limiter indicator. Fixed to 0.2V internally. Maximum allowable current is decided by external sample resistance. When the voltage of this pin exceeds 0.2V, the output will be shut down by current limit. If this function is not used, connect this pin to ground directly
5	VMIN	Minimum speed setting terminal. Connect it to VREF when disused. In case it is tied to other power supply for controlling, an isolated resistor is necessary
6	VPWM	Speed control terminal. It is full speed mode when connected to ground. If the speed is controlled by PWM mode, the frequency of control signal is 20kHz to 100kHz. Moreover, a low pass network is necessary to transfer PWM to DC level
7	COSC	PWM basic oscillation frequency generator when connected with a capacitor of 220pF. 30kHz frequency is available.
8	FG/RD	"FG" means pin 8 is an output pin of FG signal which is used for detecting rotation speed. "RD" means pin 8 is an output pin of RD signal, and is used for detecting fan rotate-stop state. "FG" and "RD" can be selected according to the requirement. This pin need to be connected with pull-up resistor when used. A new pulse will be generated once input signal changed. Keep this pin open when it is not to be used
9	HIN-	Hall sensor negative input. To prevent noise, this pin is recommended to be placed as close as possible to Hall circuit. If necessary, a capacitor may be added between HIN+ and HIN- to reduce the influence caused by noise
10	HIN+	Hall sensor positive input. To avoid noise, this pin is recommended to be placed as close as possible to Hall circuit
11	CT	Lock protection and auto start frequency generator. It is connected with an external 0.47 $\mu$ F capacitor which decides lock-rotate time and start time. If lock-rotate protection function is disused, please connect this pin to GND
12	LS	Linear start terminal. This pin is connected to VREF externally via a capacitor of 0.47 $\mu$ F to 1 $\mu$ F which enables fan start steadily. Start time is dependent to the capacitance. If linear start function is not used, connect this pin to ground
13	VREF	5V voltage reference
14	GND	Ground for circuit control
15	OUT1B	First channel N-type driver output. Push-pull output to drive external power devices
16	OUT1	First channel P-type driver output. Open-drain output, must be connected with pull-up resistor to drive external power devices in operation

**Functional Block Diagram**

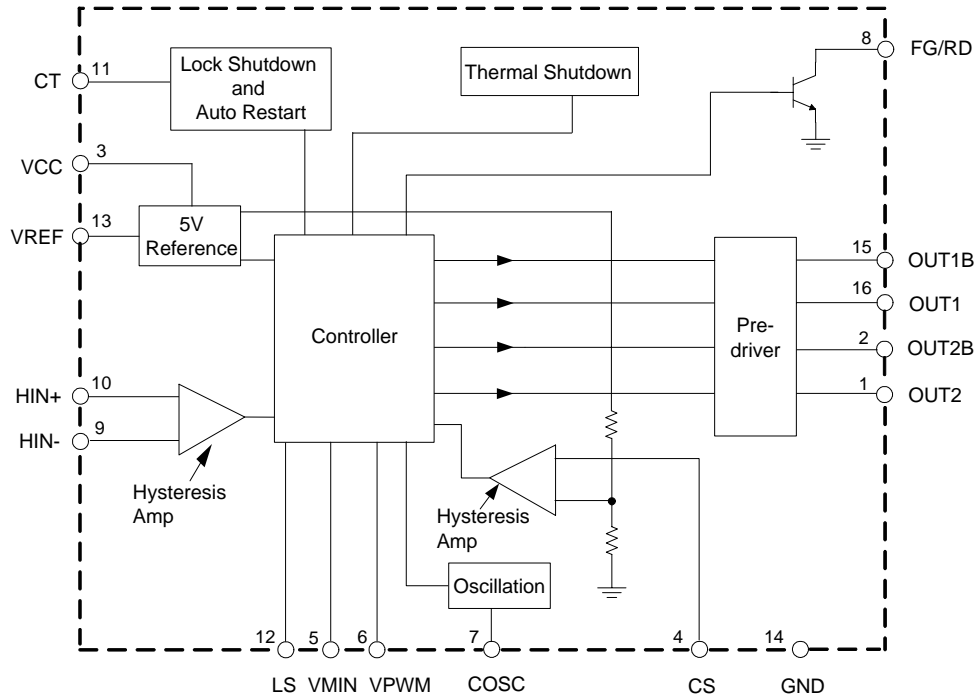

Figure 3. Functional Block Diagram of AM4967



**ADJUSTABLE-SPEED SINGLE-PHASE FULL-WAVE PRE-DRIVER FOR MOTOR** **AM4967**

**Truth Table**

1. Driver-lock.  $V_{OSC}$  is High,  $V_{PWM}$ ,  $V_{VMIN}$  and  $V_{LS}$  are low.

HIN-	HIN+	CT	OUT1	OUT1B	OUT2	OUT2B	FG/RD	Mode
H	L	L	L	L	OFF	H	L	OUT1 → OUT2 (Driver)
L	H		OFF	H	L	L	OFF	OUT2 → OUT1 (Driver)
H	L	H	OFF	L	OFF	H	L	Lock Protection
L	H		OFF	H	OFF	L	OFF	

2. Speed control.  $V_{CT}$ ,  $V_{LS}$  are low.

VPWM, VMIN	COSC	HIN-	HIN+	OUT1	OUT1B	OUT2	OUT2B	Mode
L	H	H	L	L	L	OFF	H	OUT1 → OUT2 (Driver)
		L	H	OFF	H	L	L	OUT2 → OUT1 (Driver)
H	L	H	L	OFF	L	OFF	H	Regenerative
		L	H	OFF	H	OFF	L	

**Ordering Information**

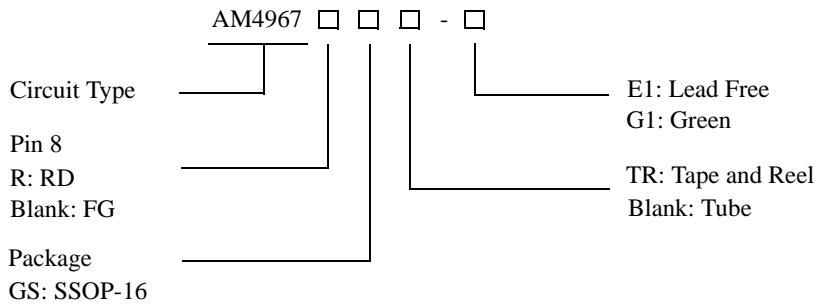

Package	Temperature Range	Part Number		Marking ID		Packing Type
		Lead Free	Green	Lead Free	Green	
SSOP-16	-30 to 105°C	AM4967GS-E1	AM4967GS-G1	AM4967GS	AM4967GS-G1	Tube
		AM4967GSTR-E1	AM4967GSTR-G1	AM4967GS	AM4967GS-G1	Tape & Reel
		AM4967RGS-E1	AM4967RGS-G1	AM4967RGS	AM4967RGS-G1	Tube
		AM4967RGSTR-E1	AM4967RGSTR-G1	AM4967RGS	AM4967RGS-G1	Tape & Reel

BCD Semiconductor's Pb-free products, as designated with "E1" suffix in the part number, are RoHS compliant. Products with "G1" suffix are available in green package.

**Absolute Maximum Ratings (Note 1)**

Parameter	Symbol	Value	Unit
Supply Voltage	$V_{CC}$	18	V
OUT1B/OUT2B Output Current	$I_{OUTB}$	20	mA
OUT1/OUT2 Sink Current	$I_{OUT}$	20	mA
OUT1B/OUT2B/OUT1/OUT2 Withstand Voltage	$V_{OUT}$	18	V
VPWM/VMIN Withstand Voltage	$V_{PWM}/V_{VMIN}$	7	V
LS Withstand Voltage	$V_{LS}$	7	V
FG/RD Withstand Voltage	$V_{FG}/V_{RD}$	$V_{CC}$	V
FG/RD Output Current	$I_{FG}/I_{RD}$	10	mA
VREF Output Current	$I_{REF}$	20	mA
Power Dissipation (Note 2)	$P_D$	800	mW
Storage Temperature Range	$T_{STG}$	-55 to 150	°C
ESD (Human Body Model)	ESD	2000	V

Note 1: Stresses greater than those listed under "Absolute Maximum Ratings" may cause permanent damage to the device. These are stress ratings only, and functional operation of the device at these or any other conditions beyond those indicated under "Recommended Operating Conditions" is not implied. Exposure to "Absolute Maximum Ratings" for extended periods may affect device reliability.

Note 2: When mounted on the specified printed circuit board (114.3mm×76.1mm×1.6mm, glass epoxy).

**Recommended Operating Conditions**

Parameter	Symbol	Min	Typ	Max	Unit
Supply Voltage	$V_{CC}$	5.5		16	V
VPWM/VMIN Input Voltage		0		5	V
Hall Input Voltage		0.2		3	V
Ambient Temperature	$T_A$	-30		105	°C

**ADJUSTABLE-SPEED SINGLE-PHASE FULL-WAVE PRE-DRIVER FOR MOTOR****AM4967****Electrical Characteristics**(V<sub>CC</sub>=12V, T<sub>A</sub>=25°C, unless otherwise specified.)

Parameter	Symbol	Conditions	Min	Typ	Max	Unit
Quiescent Current	I <sub>Q1</sub>	Lock off	8	10	12	mA
	I <sub>Q2</sub>	Lock on	8	10	12	
VREF Reference Voltage	V <sub>REF</sub>	I <sub>OUT</sub> =5mA	4.5	5.0	5.5	V
Current Limit Voltage	V <sub>LIM</sub>		186	200	215	mV
COSC High Level Voltage	V <sub>OSCH</sub>		3.0	3.4	3.8	V
COSC Low Level Voltage	V <sub>OSCL</sub>		0.9	1.1	1.3	V
COSC Frequency	f <sub>OSC</sub>	C <sub>L</sub> =220pF	25.4	30	35.5	kHz
CT High Level Voltage	V <sub>CTH</sub>		2.4	3.3	3.6	V
CT Low Level Voltage	V <sub>CTL</sub>		1.0	1.3	1.6	V
CT Charge Current	I <sub>CHG</sub>	V <sub>CT</sub> =0.5V	1.5	2	2.5	μA
CT Discharge Current	I <sub>DHG</sub>	V <sub>CT</sub> =3.5V	0.13	0.2	0.25	μA
CT Charge and Discharge Ratio	R <sub>CD</sub>	I <sub>CHG</sub> /I <sub>DHG</sub>	8.5	10	14.5	
Linear Start Charge Current	I <sub>LS</sub>	V <sub>LS</sub> =1V		0.5	0.7	μA
OUT1B/OUT2B High Level Voltage	V <sub>OBH</sub>	I <sub>OUT</sub> =10mA	V <sub>CC</sub> -1.8	V <sub>CC</sub> -0.9	V <sub>CC</sub>	V
OUT1B/OUT2B Low Level Voltage	V <sub>OBL</sub>	I <sub>OUT</sub> =10mA		0.9	1.5	V
OUT1/OUT2 Low Level Voltage	V <sub>OL</sub>	I <sub>OUT</sub> =10mA		0.45	0.8	V
FG Signal Hall Input Sensitivity	V <sub>HN</sub>	I <sub>HIN+</sub> , I <sub>HIN-</sub> difference voltage (include offset and hysteresis)		±10		mV
FG Saturation Voltage	V <sub>SAT</sub>	I <sub>SINK</sub> =5mA		200	500	mV
FG Leakage Current	I <sub>LFG</sub>	V <sub>FG</sub> =V <sub>CC</sub>			30	μA
VPWM/VMIN Bias Current	I <sub>PWMB</sub> /I <sub>VMINB</sub>	V <sub>OSC</sub> =V <sub>PWM</sub> /V <sub>VMIN</sub> =2V		0.1	3	μA



Typical Performance Characteristics

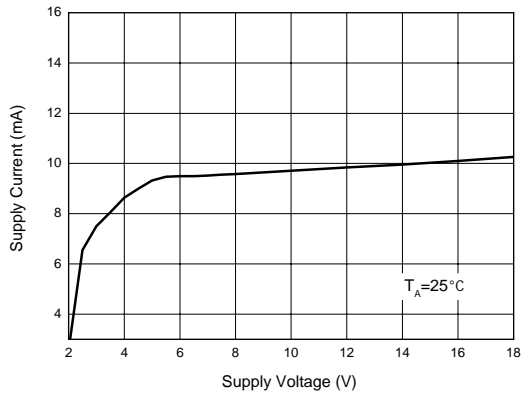

Figure 4. Supply Current vs. Supply Voltage

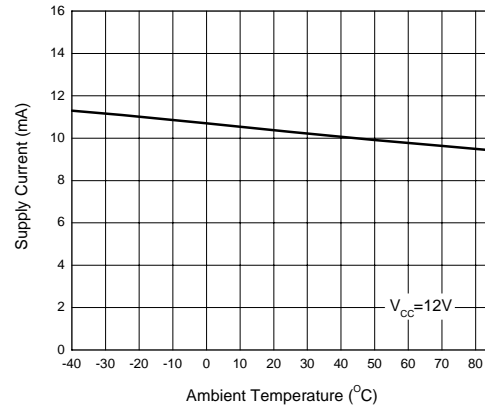

Figure 5. Supply Current vs. Ambient Temperature

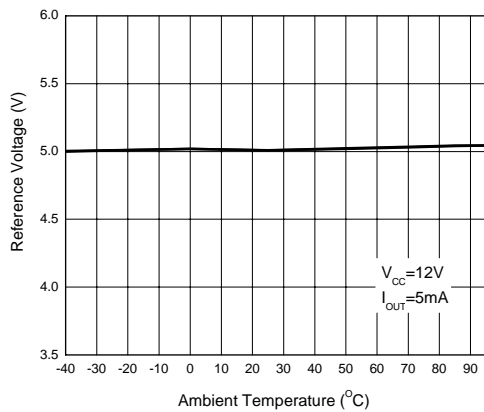

Figure 6. Reference Voltage vs. Ambient Temperature

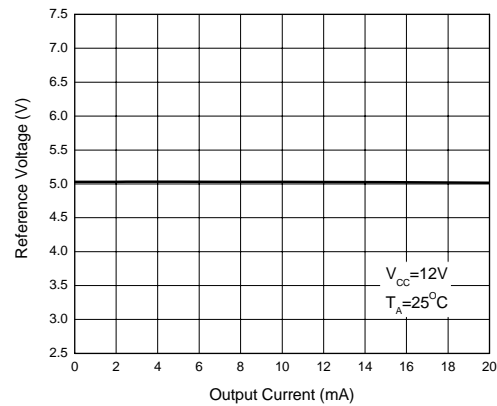

Figure 7. Reference Voltage vs. Output Current





**Typical Performance Characteristics (Continued)**

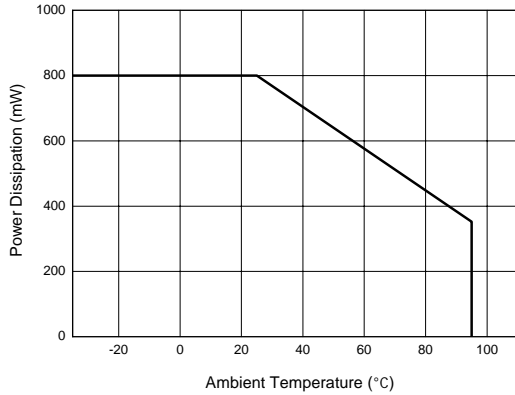

Figure 8. Power Dissipation vs. Ambient Temperature

**Operating Diagram**

Figure 9. Operating Diagram 1 of AM4967 (Speed Control, Note 3)

Note 3:

1. Minimum Speed Setting Mode (Stop Mode)

When fan rotate at low speed, its lowest speed is settable by VMIN pin voltage. If not, fan motor stops.

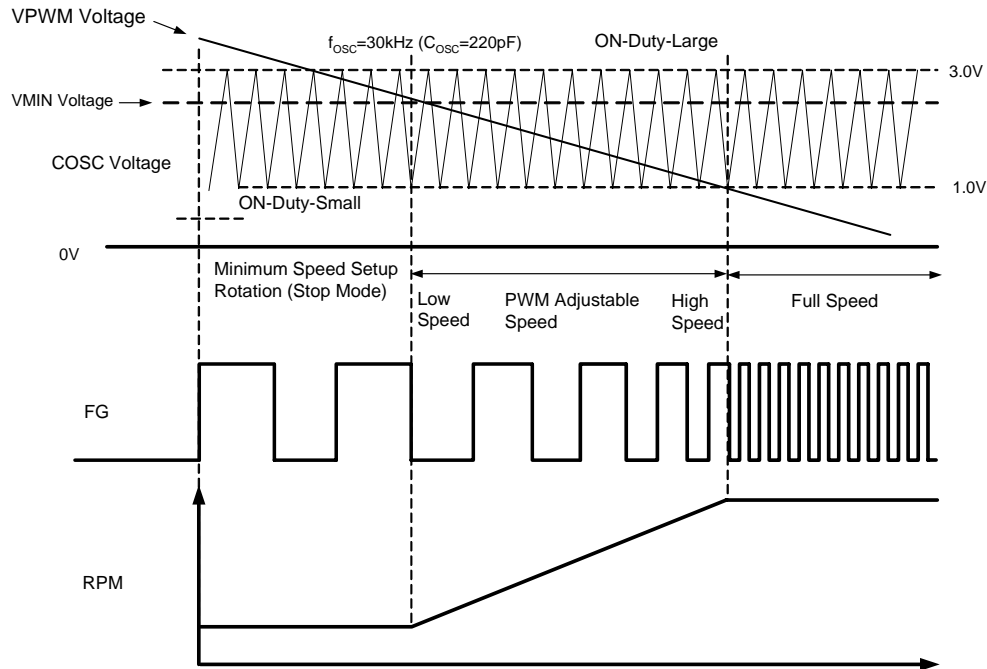
2. Low Speed to High Speed Setting Mode

PWM control system works by comparing the voltage of VPWM and COSC (1.0V to 3.0V). When VPWM voltage is low, the transistors of the upper and lower side outputs are ON. On contrary, when VPWM voltage is high, the upper side transistors are OFF. And coil current re-circulates in a lower side transistor. Therefore, as the VPWM

voltage becomes lower, output ON duty becomes large. Sequentially, coil current increases and the motor runs at high speed which is monitored by FG output while rotation-stop state is monitored by RD output.

3. Full Speed Rotation Mode

When VPWM voltage drops to 1.0V or lower, motor fan will run at full speed. (If the speed is not controlled,  $V_{PWM}=GND$ )

**Operating Diagram (Continued)**

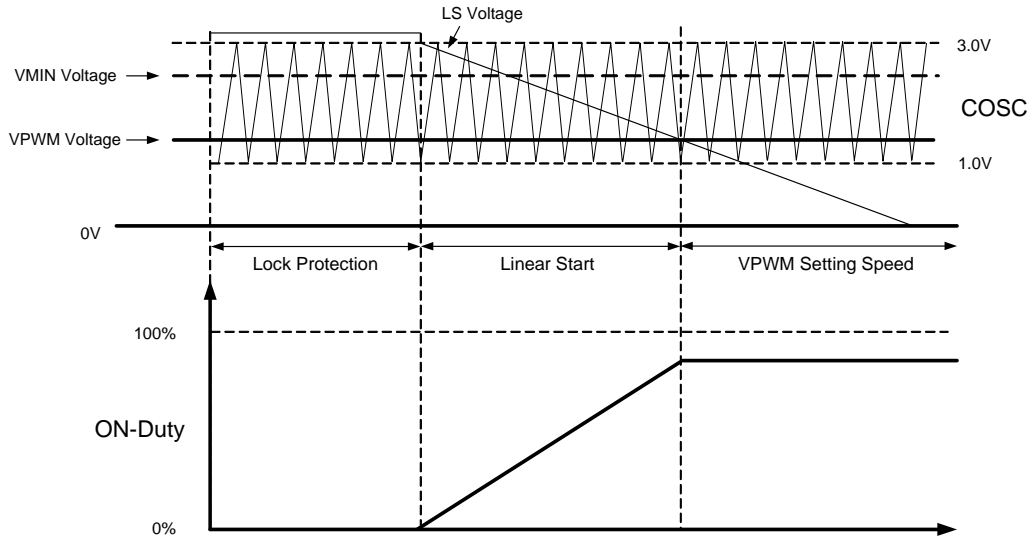

Figure 10. Operating Diagram 2 of AM4967 (Linear Start, VPWM Voltage < VMIN Voltage, Note 4)

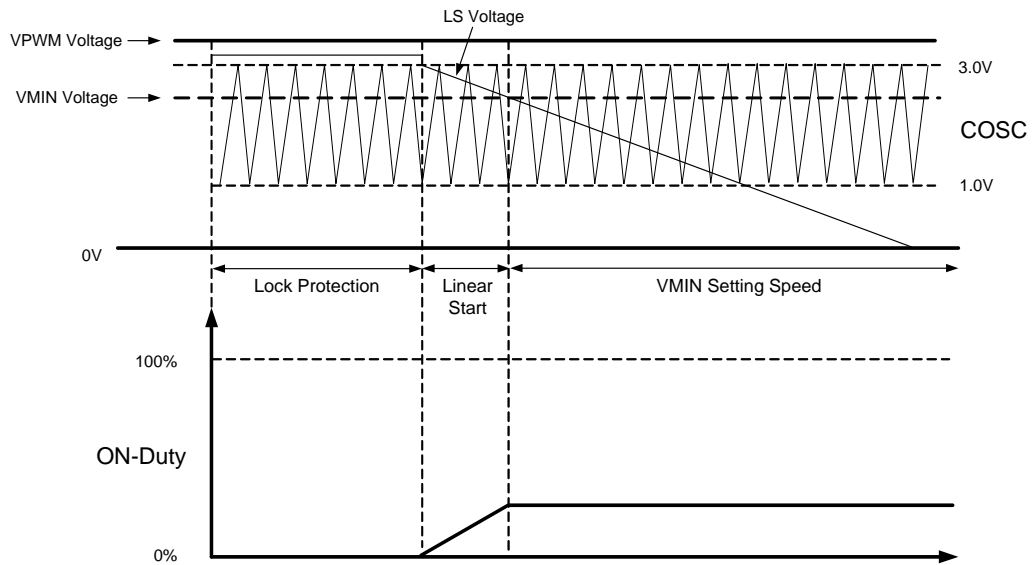

Figure 11. Operating Diagram 3 of AM4967 (Linear Start, VPWM Voltage > VMIN Voltage, Note 4)

**Operating Diagram (Continued)**

Figure 12. Operating Diagram 4 of AM4967 (Note 4)

Note 4: The inclination of LS voltage is adjusted between  $V_{LS}$  and  $V_{REF}$  according to the capacitance which is recommended to be  $0.1\mu\text{F}$  to  $1.0\mu\text{F}$ .

**Typical Application**

 Figure 13. Typical Application of AM4967 ( $V_{CC}=12V$ )

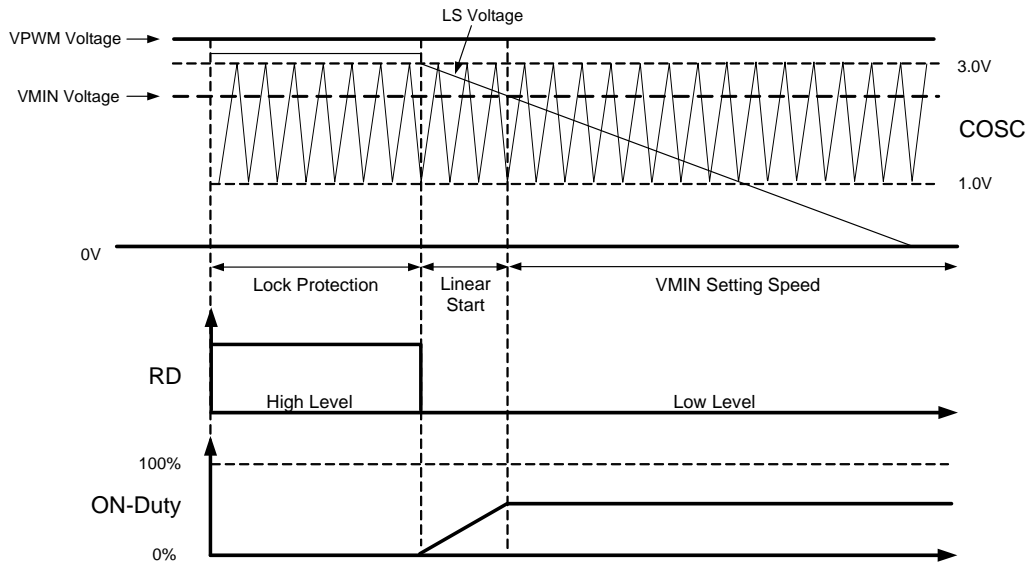
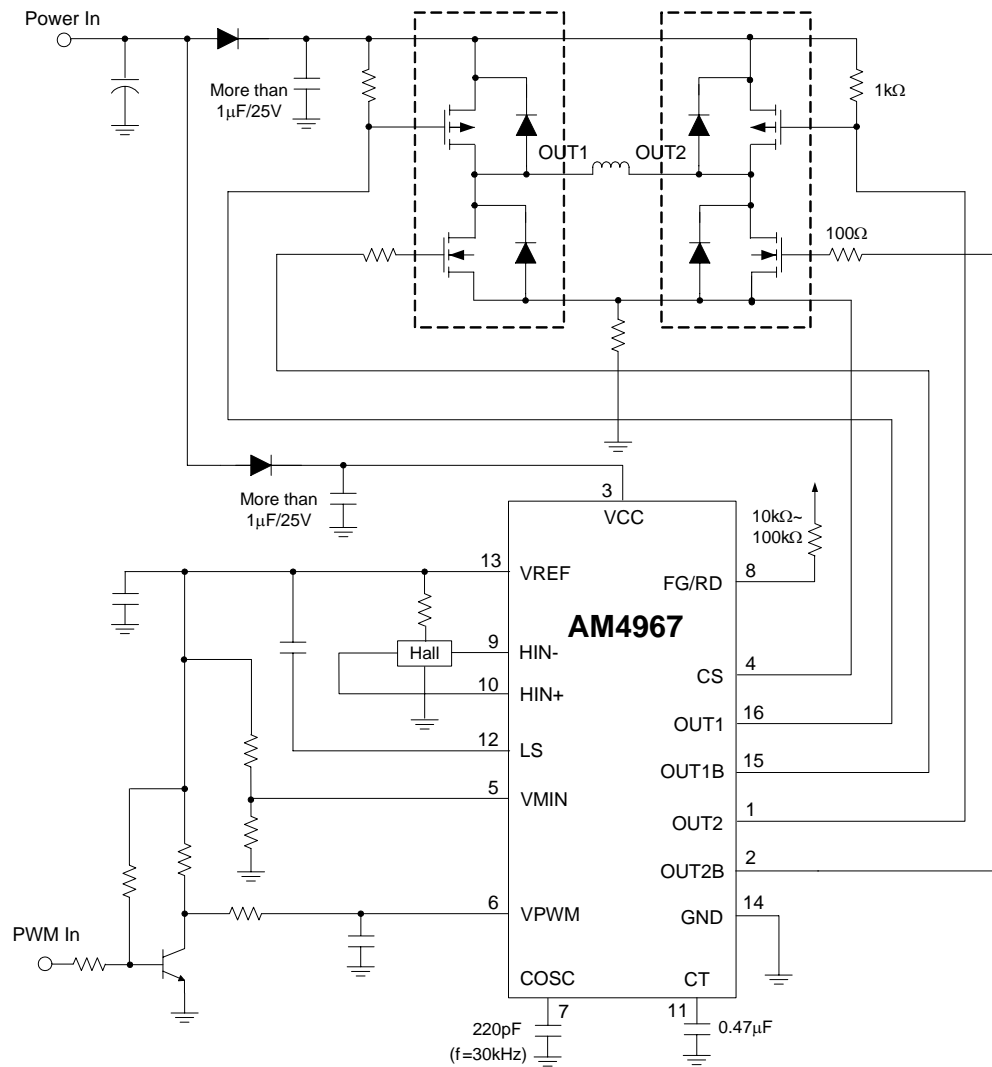

**ADJUSTABLE-SPEED SINGLE-PHASE FULL-WAVE PRE-DRIVER FOR MOTOR** **AM4967**

**Mechanical Dimensions**

**SSOP-16**

**Unit: mm(inch)**

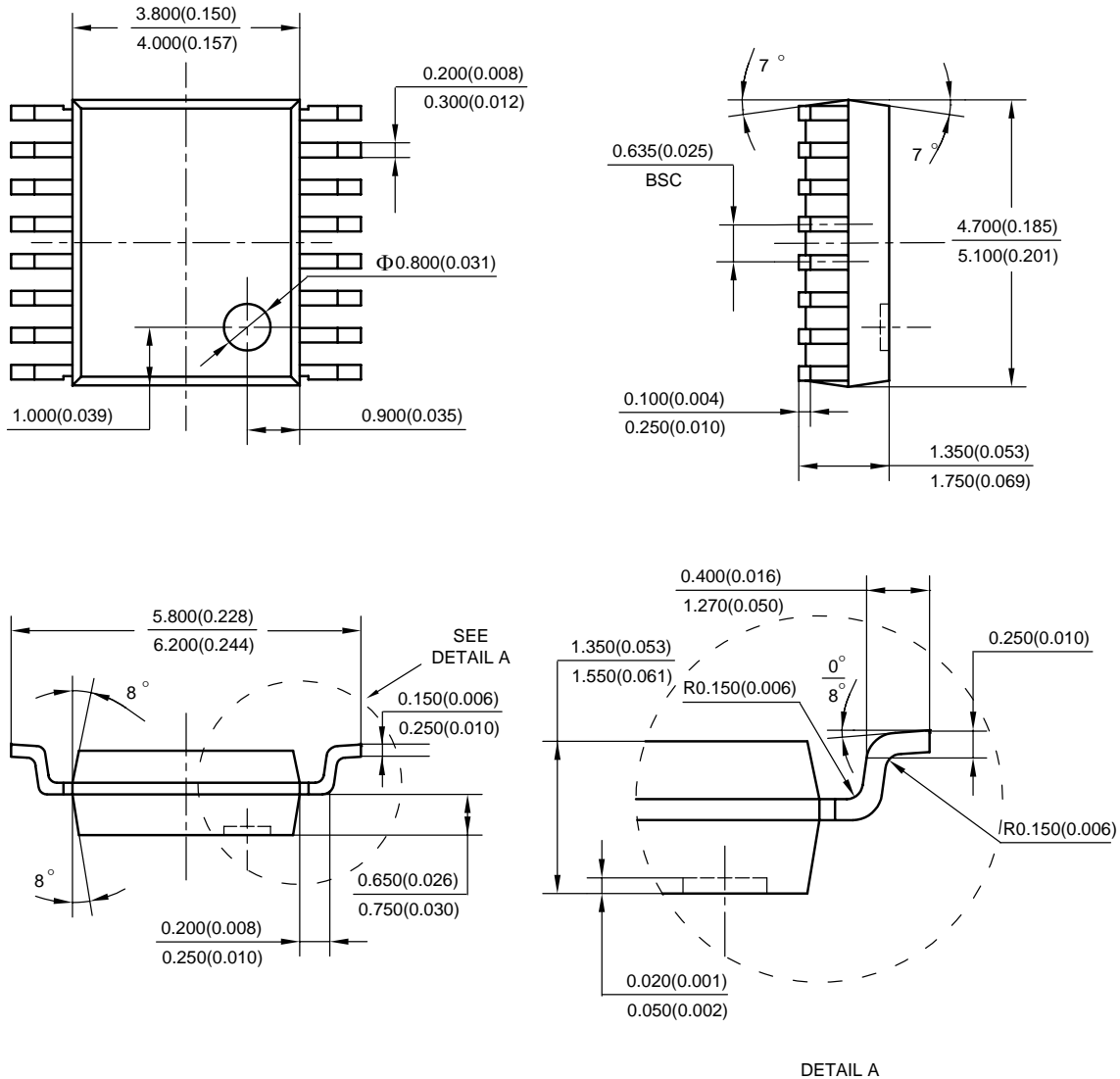



## BCD Semiconductor Manufacturing Limited

<http://www.bcdsemi.com>

### IMPORTANT NOTICE

BCD Semiconductor Manufacturing Limited reserves the right to make changes without further notice to any products or specifications herein. BCD Semiconductor Manufacturing Limited does not assume any responsibility for use of any its products for any particular purpose, nor does BCD Semiconductor Manufacturing Limited assume any liability arising out of the application or use of any its products or circuits. BCD Semiconductor Manufacturing Limited does not convey any license under its patent rights or other rights nor the rights of others.

---

#### MAIN SITE

- Headquarters  
**BCD Semiconductor Manufacturing Limited**  
No. 1600, Zi Xing Road, Shanghai Zizhu Science-based Industrial Park, 200241, China  
Tel: +86-21-24162266, Fax: +86-21-24162277

- Wafer Fab  
**Shanghai SIM-BCD Semiconductor Manufacturing Co., Ltd.**  
800 Yi Shan Road, Shanghai 200233, China  
Tel: +86-21-6485 1491, Fax: +86-21-5450 0008

#### REGIONAL SALES OFFICE

**Shenzhen Office**  
**Shanghai SIM-BCD Semiconductor Manufacturing Co., Ltd., Shenzhen Office**  
Room E, 5F, Noble Center, No.1006, 3rd Fuzhong Road, Futian District, Shenzhen, 518026, China  
Tel: +86-755-8826 7951  
Fax: +86-755-8826 7865

**Taiwan Office**  
**BCD Semiconductor (Taiwan) Company Limited**  
4F, 298-1, Rui Guang Road, Nei-Hu District, Taipei, Taiwan  
Tel: +886-2-2656 2808  
Fax: +886-2-2656 2806

**USA Office**  
**BCD Semiconductor Corp.**  
30920 Huntwood Ave. Hayward, CA 94544, USA  
Tel: +1-510-324-2988  
Fax: +1-510-324-2788