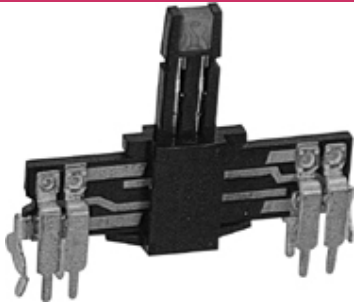
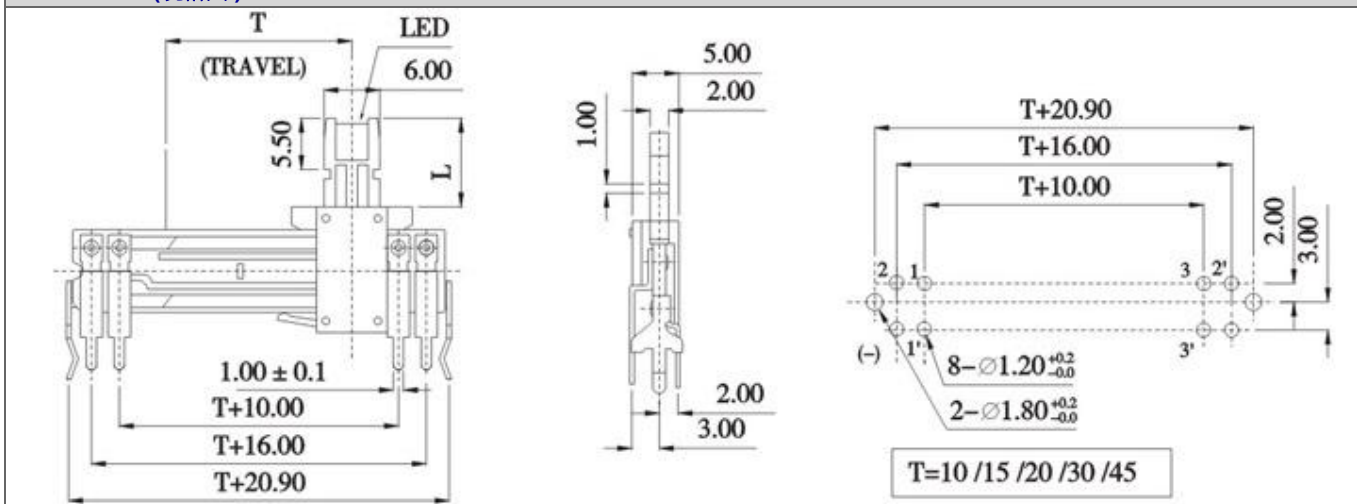

**Model(型號): ROTARY POTENTIOMETER-----S[X][X]712ED1**
[▶ Download PDF file](#)

**Features:(特點):**

Excellent operational feeling; Clear click feeling for heat controllers Smooth and wet slide feeling for electronic musical instruments Low noise ,long operational life ,highly accurate attenuation

**Applications(作用):**

Fade control for popular type audio mixers, musical keyboards  
Heat control or mose switching for car air conditioners  
Measurement instruments

**Dimensions(規格圖):**

**Specifications(規格)**

<b>Electrical Characteristics [ 電氣性能 ]</b>	
Total resistance [ 全阻抗值 ]	100Ω ~1MΩ
Total resistance tolerance [ 全阻抗值容許差 ]	±20%
Ratings power(w) [ 額定功率 ]	Travel 30mm B Single 0.2W,Dual 0.1W Except B single 0.1W,Dual 0.05W
Resistance taper [ 阻抗變化特性 ]	A,B,*C,D,W
Residual resistance(1-2/2-3) [ 殘留阻值 ]	10/20 Max.
	30/50 Max.
	50/70 Max.
	100/120 Max.
	200/220 Max.
300/320 Max.	
Sliding noise [ 滑動雜音 ]	Single unit: 100mV Max,Dual unit: 150mV Max
Insulation resistance [ 絕緣阻抗 ]	10MΩ Min. at DC 250V.
Withstanding voltage [ 耐電壓 ]	1 minute at AC 250V
Max. operating voltage [ 最高使用電壓 ]	B 200V , Except B 150V
Cang error:[運動誤差]	Volume[音量] -40dB ~0dB±3dB Max
	Tone [音質] ±3dB Max. at 50% position.
<b>Mechanical Characteristics [ 機械性能 ]</b>	
Operation torque [ 滑動力矩 ]	10~200gf.cm
Click slip out torque[掣子脫出力矩]	30~350gf.cm
Lever wobble[推柄搖晃]	2(2×L)/20mm Max. L=length of level
Lever push-pull strength[推拉強度]	3.0Kgf. cm Max. at 5 sec.
<b>Endurance Characteristics [ 耐久性能 ]</b>	
Rotational life [ 回轉壽命 ]	More than 10,000 cycles