



Shanghai Lunsure Electronic
Technology Co.,LTD
Tel:0086-21-37185008
Fax:0086-21-57152769

AM501
THRU
AM506

Features

- Low leakage
- Low forward voltage drop
- High current capability
- High forward surge current capability

**PRESS FIT AUTOMOTIVE
RECTIFIER(MOTOROLA)**

**VOLTAGE RANGE
100 TO 600 VOLTS
CURRENT 50AMPS**

Mechanical Data

- Case: Copper case
- Technology: cell with vacuum soldered
- Polarity: As marked of case bottom
- Lead: Plated lead, solderable per MIL-STD-202E method 208C
- Mounting: Press fit
- Weight: 9.0 grams

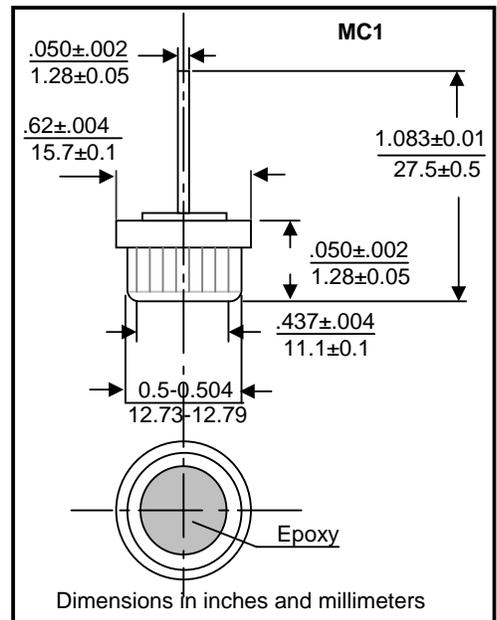

Maximum Ratings and Electrical Characteristics

- Rating at 25°C ambient temperature unless otherwise specified
- Single phase, half wave, 60Hz, resistive or inductive load
- For capacitive load derate current by 20%

Parameters	Symbols	AM501	AM502	AM503	AM504	AM506	Units
Maximum repetitive peak reverse voltage	V_{RRM}	100	200	300	400	600	Volts
Maximum RMS voltage	V_{RMS}	70	140	210	280	420	Volts
Maximum DC blocking voltage	V_{DC}	100	200	300	400	600	Volts
Maximum Average rectified forward current at $T_c=110^\circ\text{C}$	I_o	50					Amps
Peak forward surge current 8.3ms single half sine-wave superimposed on rated load (JE DEC Method)	I_{FSM}	500					Amps
Rating for fusing($t<8.3\text{ms}$)	I^2t	1494					A^2S
Maximum instantaneous forward voltage drop at 100A	V_F	1.05					Volts
Maximum DC reverse current $T_A=25^\circ\text{C}$ at rated DC blocking voltage $T_A=150^\circ\text{C}$	I_R	5.0 450					μA
Typical thermal resistance	$R_{\theta JC}$	0.8					$^\circ\text{C}/\text{W}$
Operating and storage temperature	T_J, T_{STG}	-65 to +175					$^\circ\text{C}$

Notes: 1.Enough heatsink must be considered in application.

AM501 THRU AM506

Ratings and Characteristic Curves

FIG.1-TYPICAL FORWARD CURRENT DERATING CURVE

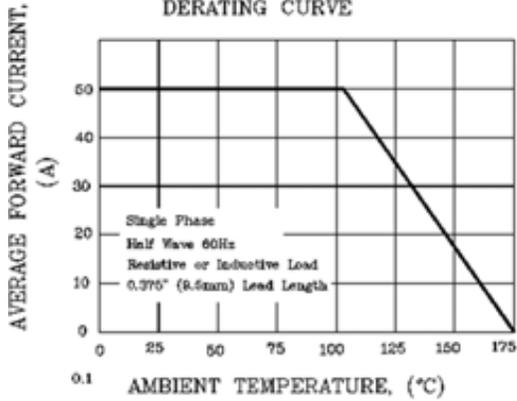

FIG.2-MAXIMUM NON-REPETITIVE PEAK FORWARD SURGE CURRENT

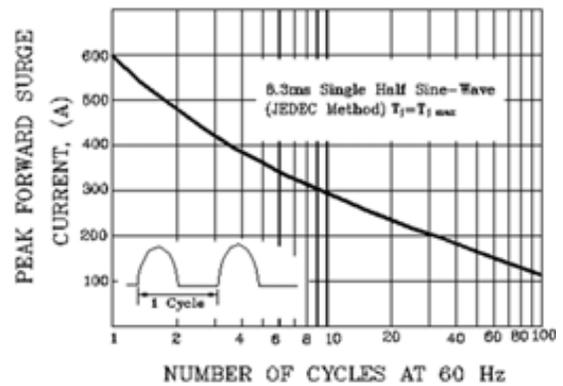

FIG.3-TYPICAL INSTANTANEOUS FORWARD CHARACTERISTICS

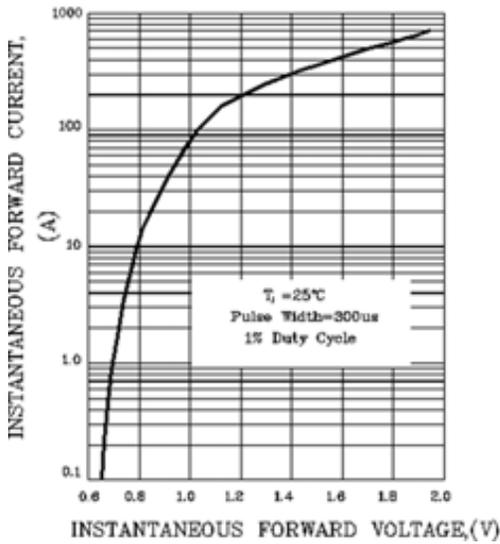

FIG.4- FORWARD POWER DISSIPATION

