

RATIOMETRIC VOLTAGE TRANSMITTER AM417

FEATURES

- Supply Voltage $5V \pm 5\%$ (Ratio Range)
- Wide Operating Temperature Range: $-40^{\circ}\text{C} \dots +100^{\circ}\text{C}$
- Ratiometrical Current Source for Transducer Excitation
- Instrumentation Amplifier Input
- Voltage Output Driver
Open Collector:
 $V_{OUT} = 0.5\text{--}4.5\text{V}$
 $I_{OUT} = +10\text{mA}$
- Adjustable Gain, Offset, and Output Voltage Range
- Small Package Dimensions: SO8
- Low Cost

APPLICATIONS

- Industrial Process Control
- Automotive Applications
- Sensor Transmitter

GENERAL DESCRIPTION

The AM417 is a low cost ratiometrical voltage transmitter, designed for flexible bridge input signal conditioning. The IC contains a ratiometric current source for transducer excitation, a high accuracy instrumentation amplifier for differential input signals, and a voltage output driver. Gain, offset, and output voltage range are adjustable by external resistors. The voltage output stage is designed as an open collector stage. The output current is +10mA. A simple current limitation is possible by adding an external resistor. With its functional blocks and possibilities to adjust all important parameters for sensor calibration, the small package dimensions (SO8), and the low costs the AM417 is ideally suited for automotive sensor interface applications.

DELIVERY

- DIL8 packages (samples)
- SOP8 packages
- Dice on 5" blue foil

BLOCK DIAGRAM

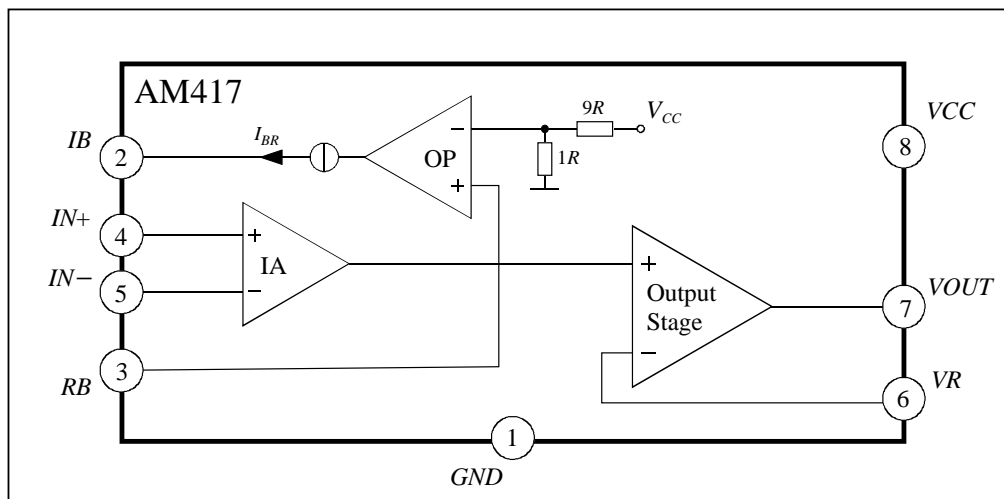

Figure 1

analog microelectronics

Analog Microelectronics GmbH
An der Fahrt 13, D – 55124 Mainz
Internet: www.analogmicro.de

Phone: +49 (0)6131/91 073 – 0
Fax: +49 (0)6131/91 073 – 30
E-Mail: info@analogmicro.de

April 99

1/6

Rev. 2.1

RATIOMETRIC VOLTAGE TRANSMITTER AM417

ELECTRICAL SPECIFICATIONS

$T_{amb} = 25^{\circ}\text{C}$, $V_{CC} = 5\text{V}$ (unless otherwise noted)

Parameter	Symbol	Conditions	Min.	Typ.	Max.	Unit
Voltage Range (Ratio Range)	V_{CC}		4.75	5	5.25	V
Maximum Supply Voltage	V_{CCmax}				6	V
Quiescent Current	I_{CC}	$R_{RB} = 500\Omega$, $I_{IB} = 1\text{mA}$			6.2	mA
Temperature Specifications						
Operating	T_{amb}		-40		100	$^{\circ}\text{C}$
Storage	T_{st}		-55		125	$^{\circ}\text{C}$
Junction	T_j				150	$^{\circ}\text{C}$
Thermal Resistance	Θ_{ja}	DIL8 plastic package		110		$^{\circ}\text{C}/\text{W}$
	Θ_{ja}	SOS plastic package		180		$^{\circ}\text{C}/\text{W}$
Ratiometric Current Source – Transducer						
Internal Sense Voltage	V_{RB}	ratiometric with V_{CC} , $V_{VCC} = 5\text{V}$		0.5		V
Output Current Range	I_{IB}		0.50		1.25	mA
Output Current	I_{IB}	ratiometric with V_{CC} , $R_{RB} = 500\Omega$, $V_{VCC} = 5\text{V}$	0.98	1	1.02	mA
Ratiometric Error	$RAT@IB$	$V_{VCC} = 5.25\text{V}$, $RAT@IB = 1.05 V_{RB} (V_{VCC} = 5\text{V})$ $- V_{RB} (V_{VCC} = 5.25\text{V})$			± 1	mV
I_{RB} vs. Temperature	dI_{RB}/dT	$I_{IB} = 1\text{mA}$			± 20	ppm/ $^{\circ}\text{C}$
Output Voltage Range	V_{IB}	$I_{IB} = 1.25\text{mA}$	1.5		$V_{CC}-0.5$	V
Output Resistance	R_{IB}	$I_{IB} = 1\text{mA}$, $R_{IB} = \Delta U_{IB}/\Delta I_{IB}$, $V_{VIB} = 5\text{V}$, $I_{IB} = 1\text{mA}$	1.5	4.5		M Ω
Power Supply Rejection Ratio	ΔI_{IB}	$\Delta V_{CC} = 4.75\text{V} - 5.25\text{V}$, $V_{VIB} = 5\text{V}$, $I_{IB} = 1\text{mA}$	76	90		dB
Instrumentation Amplifier						
Input Voltage Range	V_{IN+-}		1.5		$V_{CC}-2$	V
Internal Gain	G_{IA}	$V_{IN-} = 2\text{V}$, $\Delta V_{IN} = 200\text{mV}$ $G_{IA} = \Delta V_{VIA}/\Delta V_{IN}$	9.8	10.0	10.2	
Common Mode Rejection Ratio	$CMRR$		80	90		dB
Power Supply Rejection Ratio	$PSRR$		74	80		dB
Offset Voltage	V_{OS}				± 3	mV
V_{OS} vs. Temperature	dV_{OS}/dT				± 10	$\mu\text{V}/^{\circ}\text{C}$
Input Bias Current	I_B	$V_{IN} = 2\text{V}$		25	75	nA
Output Voltage Range	V_{VIA}		0		$V_{CC}-2$	V
Output Resistance	R_{OUT}			20		k Ω
Nonlinearity		$\Delta V_{IN} = 200\text{mV}$, ideal input			0.1	% FS
Voltage Output Stage						
Adjustable Gain	G_{OUT}		2		11	
Input Voltage Range	V_{VR}		0		$V_{CC}-2.5$	V
Power Supply Rejection Ratio	$PSSR$		-72	-90		dB
Offset Voltage	V_{OS}				± 3.0	mV
V_{OS} vs. Temperature	dV_{OS}/dT	$\Delta V_{IN} = 50\text{mV}$			± 15	$\mu\text{V}/^{\circ}\text{C}$
Input Current	I_{IN}	$\Delta V_{IN} = 50\text{mV}$		20	75	nA
Output Voltage Range	V_{OUT}	with transistor BCW68H $I_{OUT} = 10\text{mA}$ (see figure 5)	0.5		4.5	V

RATIOMETRIC VOLTAGE TRANSMITTER AM417

Parameter	Symbol	Conditions	Min.	Typ.	Max.	Unit
Voltage Output Stage (cont.)						
Output Current	I_{OUT}	with transistor BCW68H			12.5	mA
Output Current Pin V_{OUT}	$I_{V_{OUT}}$	pin V_{OUT}	100	200	300	μ A
Current Limitation Threshold	V_{THRESH}	$V_{THRESH} = V_{VCC} - V_{V_{OUT}min}$, $R_2 = 27\Omega$, $I_{OUT} \approx 14mA$	120	150	180	mV
V_{THRESH} vs. Temperature	dV_{THRESH}/dT	$-40...+100^\circ C$	1.00		1.15	mV
Output Resistance	R_{OUT}	virtual		0.1	0.85	Ω
Linearity		ideal input			0.01	%FS

BOUNDARY CONDITIONS

Parameter	Symbol	Conditions	Min.	Typ.	Max.	Unit
Resistor Adjustment Current Source (Transducer)	R_1		400		1000	Ω
Gain Resistor Sum	$R_3 + R_4$				2.0	k Ω
Capacitor Power Supply	C_1		100			nF
Capacitor Frequency Compensation (Output Stage)	C_2		4.3		5.8	nF
Capacitor Load (Output Stage)	C_3		1.0		10.0	nF
Resistor Sense Current Limitation	R_2		0		50	Ω

FUNCTIONAL DIAGRAM

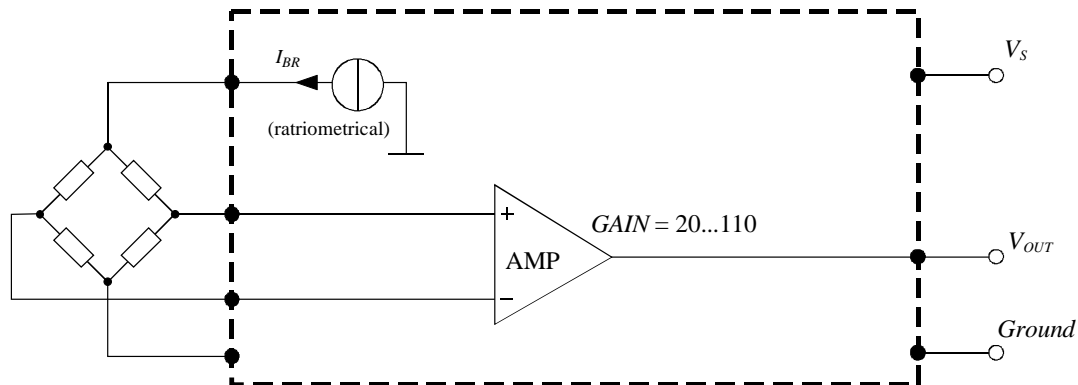

Figure 2

FUNCTIONAL DESCRIPTION

The AM417 is an integrated low cost ratiometric voltage transmitter specially designed for bridge input signals in automotive applications. With its integrated, ratiometrical current source the AM417 is ideally suited for the signal conditioning of piezoresistive pressure transducers and allows an easy temperature compensation and span adjustment of a these kinds of sensors.

The AM417 consists of 3 basic functional blocks:

1. A **Ratiometrical Current Source** for transducer excitation:

The current I_{IB} can be adjusted by the variation of the resistor R_1 by the following relation:

$$I_{IB} = \frac{V_{VCC}}{10R_1}$$

2. An **Instrumentation Amplifier Input Stage** with a fixed gain $G_{IA} = 10$ for pre-amplifying the bridge input signal.
3. An **Open Collector Output Stage** with the following functions:

- **Voltage Output:** As output is used a voltage amplifier which has an external PNP-open collector stage T_1 which is able to push a maximum current of $I_{OUT} = 5\text{mA}$. The gain G_{OUT} is adjustable by the external resistors R_3 and R_4 between $G_{OUT} = 2\dots 11$:

$$G_{OUT} = \frac{R_3}{R_3 + R_4}$$

The gain G of the complete system becomes then $G = G_{IA} G_{OUT}$.

- **Current Limitation:** A simple clamp stage for the output pin V_{OUT} limits the voltage drop against V_{CC} to

$$V_{OUT_{\max}} = V_{VCC} - 1.5V_{BE}(T_1).$$

The maximum current can be set by adding a resistor in series to the Emitter of the transistor T_1 at the output stage (see figure 4). For the maximum output current is valid:

$$I_{OUT_{\max}} = \frac{V_{TRESH} - V_{BE}(T_1)}{R_2} \approx \frac{370\text{mV}}{R_2}.$$

If no current limitation is required, the Emitter of the transistor T_1 has to be directly connected to V_{CC} ($R_2 = 0\Omega$). A proper thermic coupling of the Transistor T_1 (V_{BE} -Drift: $-2\text{mV}/^\circ\text{C}$ typ.) and the AM417 reduces the resulting temperature drift of I_{OUT} and increases the performance of the current limitation.

Adjustment of Output Voltage Range

The span of the output voltage could be adjusted by the gain G_{OUT} of the output stage. The offset of the output voltage can be adjusted in the same way as the adjustment of the sensor offset using the resistors R_{O1} and R_{O2} (figure 4).

RATIOMETRIC VOLTAGE TRANSMITTER AM417

PINOUT

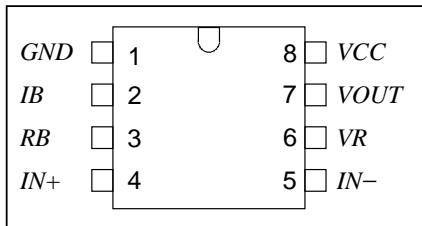

Figure 3

PIN	NAME	DESIGNATION
1	<i>GND</i>	IC Ground
2	<i>IB</i>	Output Current Source
3	<i>RB</i>	Adjustment Current Source
4	<i>IN+</i>	Input Positive
5	<i>IN-</i>	Input Negative
6	<i>VR</i>	Adjustment Gain Output Stage
7	<i>VOUT</i>	Out Output Stage
8	<i>VCC</i>	Supply Voltage

DELIVERY

The AM417 is available in:

- 8 pin DIL packages (samples)
- SO 8 packages
- Dice on 5" blue foil

PACKAGE DIMENSIONS SOP8

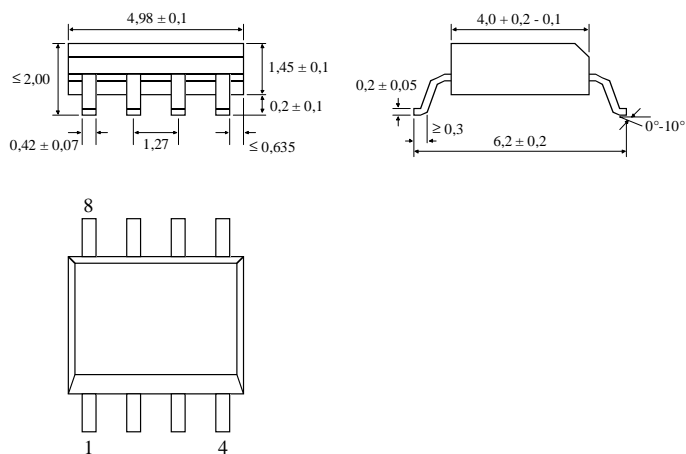

Figure 4

RATIOMETRIC VOLTAGE TRANSMITTER AM417

APPLICATION FOR OUTPUT VOLTAGE 0.5...4.5V

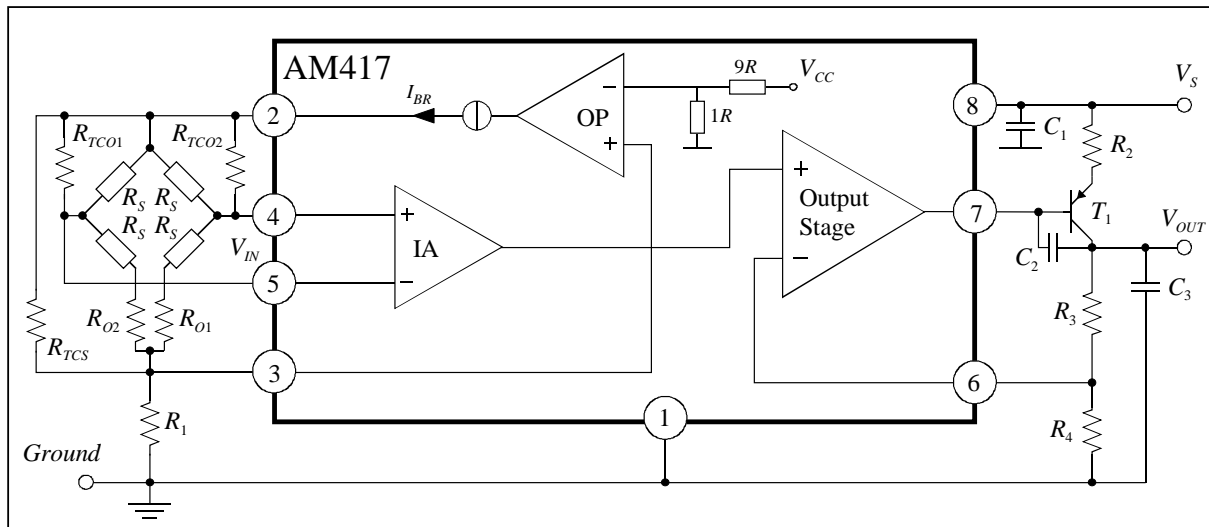

Figure 5

The current application shows the basic functions of the AM417. With the given values of the external components (see *List of External Components*) the following application features are adjusted:

- $V_{IN} = 100\text{mV}$
- $G = G_{IA} G_{OUT} = 40$
- $V_{OUT} = 0.5 - 4.5\text{V}$
- $I_{OUT} = +10\text{mA} - 0.25\text{mA}$
- $I_{BR} = 1\text{mA}$ (ratiometrical supply current for the pressure transducer)

LIST OF EXTERNAL COMPONENTS

Symbol	Description	Value	Unit
T_1	BCW68H, BC557C (or similar)	low drop, high β at 10mA	PNP
R_1	$I_{BR} = 1\text{mA}$	500	Ω
R_2	$I_{OUT} = 10\text{mA min (100}^\circ\text{C)}$	15	Ω
R_3	} Span (Gain adjustment) $V_{OUT} = R_3 / (R_3 + R_4) G$	500	Ω
R_4		1.5	k Ω
R_5	typical transducer resistor	3.0 (typ.)	k Ω
R_{TCS}	TC span compensation	10 - 120	k Ω
R_{O1}, R_{O2}	Offset adjustment	0 - 500	Ω
R_{TC01}, R_{TC02}	TC offset adjustment	0.1 - 10.0	M Ω
C_1		330	nF
C_2	$\pm 10\%$	4.7	nF
C_3	$\pm 10\%$	1.0	nF

The information provided herein is believed to be reliable; however, Analog Microelectronics assumes no responsibility for inaccuracies or omissions. Analog Microelectronics assumes no responsibility for the use of this information, and all use of such information shall be entirely at the user's own risk. Prices and specifications are subject to change without notice. No patent rights or licences to any of the circuits described herein are implied or granted to any third party. Analog Microelectronics does not authorise or warrant any Analog Microelectronics product use in life support devices and/or systems.