

# DATA SHEET

## **UAA3220TS** Frequency Shift Keying (FSK)/Amplitude Shift Keying (ASK) receiver

Product specification  
Supersedes data of 1998 April 10  
File under Integrated Circuits, IC01

1999 Jan 22

## Frequency Shift Keying (FSK)/Amplitude Shift Keying (ASK) receiver

### UAA3220TS

#### FEATURES

- Low cost single-chip ASK or FSK receiver
- Superheterodyne architecture with high integration level
- Few external low cost components and crystal required
- Wide supply voltage range
- Low power consumption
- Wide frequency range, 250 to 920 MHz
- High sensitivity
- IF bandwidth determined by application
- High selectivity
- Automotive temperature range
- SSOP24 package.

#### Applications

- Keyless entry systems
- Car alarm systems
- Remote control systems
- Security systems
- Telemetry systems
- Wireless data transmission
- Domestic appliance.

#### GENERAL DESCRIPTION

The UAA3220TS is a fully integrated single-chip receiver, primarily intended for use in VHF and UHF systems. It supports both Amplitude Shift Keying (ASK) and Frequency Shift Keying (FSK) demodulation.

By connecting DEMO1 (pin 10) to ground during realisation of the receiver module the UAA3220TS works as an ASK receiver (see Fig.10). By connecting pin 10 as shown in Fig.9 the UAA3220TS works as an FSK receiver. The UAA3220TS incorporates a crystal stabilized local oscillator, frequency multiplier, balanced mixer, post mixer amplifier, limiter, Received Signal Strength Indicator (RSSI), FSK demodulator, data filter, data slicer and power down circuit.

#### QUICK REFERENCE DATA

SYMBOL	PARAMETER	CONDITIONS	MIN.	TYP.	MAX.	UNIT
$V_{CC}$	supply voltage		2.7	–	5.5	V
$I_{CC}$	supply current	$f_{i(RF)} = 433.92$ MHz; FSK mode operating mode on; $V_{PWD} = 0$ V	2.8	4.3	5.8	mA
		operating mode off; $V_{PWD} = V_{CC}$	–	3	30	$\mu$ A
<b>ASK mode</b>						
$P_{i(max)(ASK)}$	maximum input power	BER $\leq$ 3%	–22	–16	–10	dBm
$\Phi_{i(ASK)}$	sensitivity into pin MIXIN	$f_{i(RF)} = 433.92$ MHz; BER $\leq$ 3%	–	–119	–113	dBm
<b>FSK mode</b>						
$P_{i(max)(FSK)}$	maximum input power	BER $\leq$ 3%	–6	0	+1	dBm
$\Phi_{i(FSK)}$	sensitivity into pin MIXIN	$f_{i(RF)} = 433.92$ MHz; BER $\leq$ 3%	–	–103	–100	dBm

# Frequency Shift Keying (FSK)/Amplitude Shift Keying (ASK) receiver

UAA3220TS

## ORDERING INFORMATION

TYPE NUMBER	PACKAGE		
	NAME	DESCRIPTION	VERSION
UAA3220TS	SSOP24	plastic shrink small outline package; 24 leads; body width 5.3 mm	SOT340-1

## BLOCK DIAGRAM

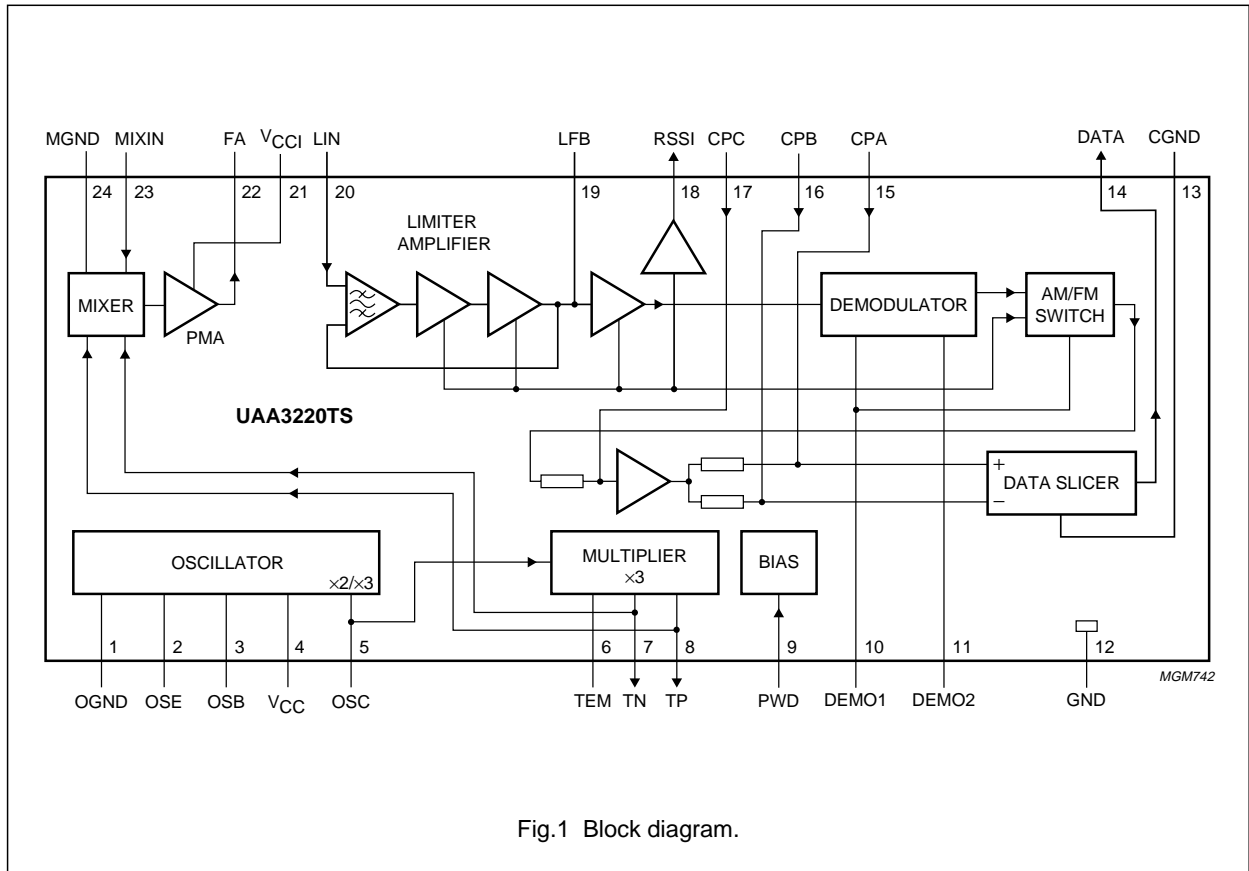

Fig.1 Block diagram.

# Frequency Shift Keying (FSK)/Amplitude Shift Keying (ASK) receiver

## UAA3220TS

### PINNING

SYMBOL	PIN	DESCRIPTION
OGND	1	oscillator ground
OSE	2	oscillator emitter
OSB	3	oscillator base
V <sub>CC</sub>	4	positive supply voltage
OSC	5	oscillator collector
TEM	6	frequency multiplier emitter resistor
TN	7	frequency multiplier negative output
TP	8	frequency multiplier positive output
PWD	9	power down control input
DEMO1	10	FM demodulator 1, ASK/FSK switch
DEMO2	11	FM demodulator 2
GND	12	general ground
CGND	13	comparator ground
DATA	14	data output
CPA	15	comparator input A
CPB	16	comparator input B
CPC	17	comparator input C
RSSI	18	RSSI output
LFB	19	limiter feedback
LIN	20	limiter input
V <sub>CCI</sub>	21	IF amplifier positive supply voltage
FA	22	IF amplifier output
MIXIN	23	mixer input
MGND	24	mixer ground

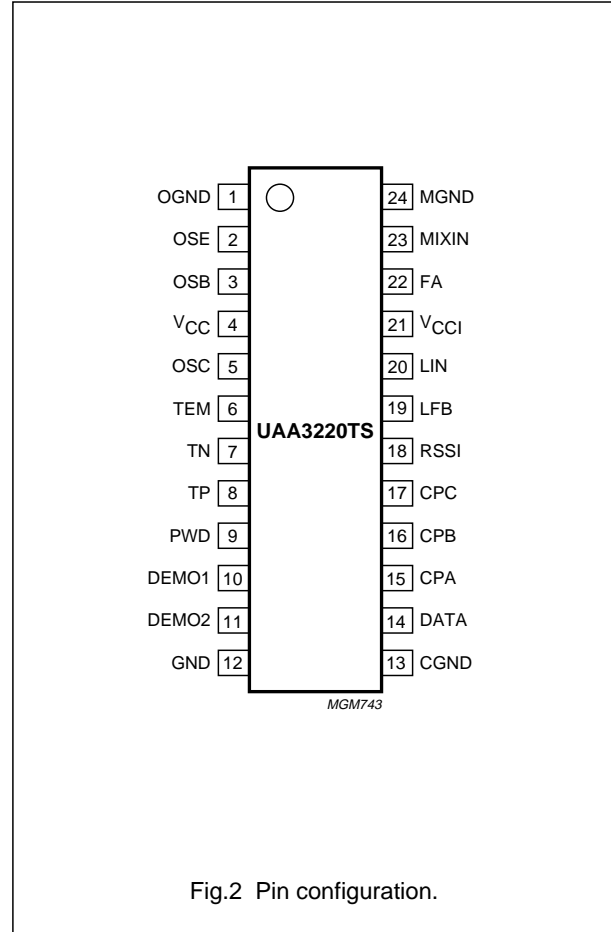

Fig.2 Pin configuration.

# Frequency Shift Keying (FSK)/Amplitude Shift Keying (ASK) receiver

UAA3220TS

## FUNCTIONAL DESCRIPTION

### Mixer

The mixer is a single-balanced emitter-coupled mixer with internal biasing. Matching of the RF source impedance to the mixer input requires an external matching network.

### Oscillator

The oscillator is based on a transistor connected in common collector configuration followed by a cascode stage driving a tuned circuit. The voltage at this tuned circuit drives the frequency multiplier. The bias current of the oscillator is set by an off-chip resistor (R40 in the application diagram of Fig.9) to a typical value of 260  $\mu$ A at 433.92 MHz (R40 = 1.8 k $\Omega$ ). The oscillator frequency is controlled by an off-chip overtone crystal (X40). Off-chip capacitors between base and emitter (C42) and ground (C41) make the oscillator transistor appear as having negative resistance at small signal levels. This causes the oscillator to start. A parallel resonance circuit (L40 and C41) connected to the emitter of the oscillator transistor prevents oscillation at the fundamental frequency of the crystal. The LC tank circuit at the output of the oscillator is used to select either the fundamental, the second or the third harmonic of the oscillator frequency.

### Frequency multiplier

The frequency multiplier is an emitter-coupled transistor pair driving an off-chip balanced tuned circuit. The bias current of this emitter coupled pair is set by an off-chip resistor (R50) to a typical value of 350  $\mu$ A at 433.92 MHz (R50 = 1.2 k $\Omega$ ). The oscillator output signal is AC-coupled to one of the inputs of the emitter-coupled pair. The other input is connected to ground via an on-chip capacitor. The output voltage of the frequency multiplier drives the switching stage of the mixer. The bias voltage at this point is set by an off-chip resistor (R51) to allow sufficient voltage swing at the mixer outputs.

### Post mixer amplifier

The Post Mixer Amplifier (PMA) is a differential input, single-ended output amplifier. Amplifier gain is provided in order to reduce the influence of the limiter noise figure on the total noise figure.

### Limiter

The limiter is a single-ended input multiple stage amplifier with high total gain. Amplifier stability is achieved by means of an external DC feedback capacitor (C21), which is also used to determine the lower limiter cut-off frequency. An RSSI signal proportional to the limiter input signal is provided. Figure 3 shows the DC voltage at pin 18 (RSSI) as a function of the input voltage (RMS value) at pin 20 (LIN). It also gives the typical IF of 10.7 MHz. The lower knee of the level curve (see Fig.3) is determined by the effective noise bandwidth and is, consequently, slightly higher.

### IF filter

IF filtering with high selectivity is realized by means of an external ceramic filter (X20), which feeds the IF from the PMA to the limiter.

### FM demodulator

Coming from the limiter the FSK signal is fed differential to the input of the FM demodulator. After buffering the signal is fed to a phase detector. The phase shift is generated by an external LC combination connected to DEMO1 (pin 10) and DEMO2 (pin 11). The baseband signal is coupled out single ended via an output buffer and is fed to the FSK input of the ASK/FSK switch.

### ASK/FSK switch

The selection of either ASK or FSK reception will be done by the DEMO1 (pin 10). Grounding this pin to 0 V will switch the IC to ASK mode. Additionally the FM demodulator and parts of the data slicer will be switched off. In FSK mode DEMO1 (pin 10) is connected to DEMO2 (pin 11) via a LC combination (see Fig.9).

### Data filters

After demodulation a two-stage data filtering circuit is provided in order to suppress unwanted frequency components. Two RC low-pass filters with on-chip resistors are provided which are separated by a buffer stage.

## Frequency Shift Keying (FSK)/Amplitude Shift Keying (ASK) receiver

UAA3220TS

### Data slicer

Data detection is provided by means of a level comparator with adaptive slice reference. After the first data filter stage the pre-filtered data is split into two paths. One passes the second data filter stage and is fed to the positive comparator input. The other path is fed to an integration circuit with a large time constant in order to derive the average value (DC component) as an adaptive slice reference which is presented to the negative comparator input. The internal buffer provides 13 dB AC voltage gain. The adaptive reference allows to detect the received data over a large range of noise floor levels. The integration circuit consists of a simple RC low-pass filter with on-chip resistors. The data slicer output is designed with internal pull-up.

### RSSI buffer

The RSSI buffer is an amplifier with a voltage gain of 0 dB. At FSK receive mode the RSSI output provides a field strength indication. It has an output impedance of 10 k $\Omega$ . Figure 3 shows the level curve (RSSI curve) as a function of the limiter input voltage (RMS value).

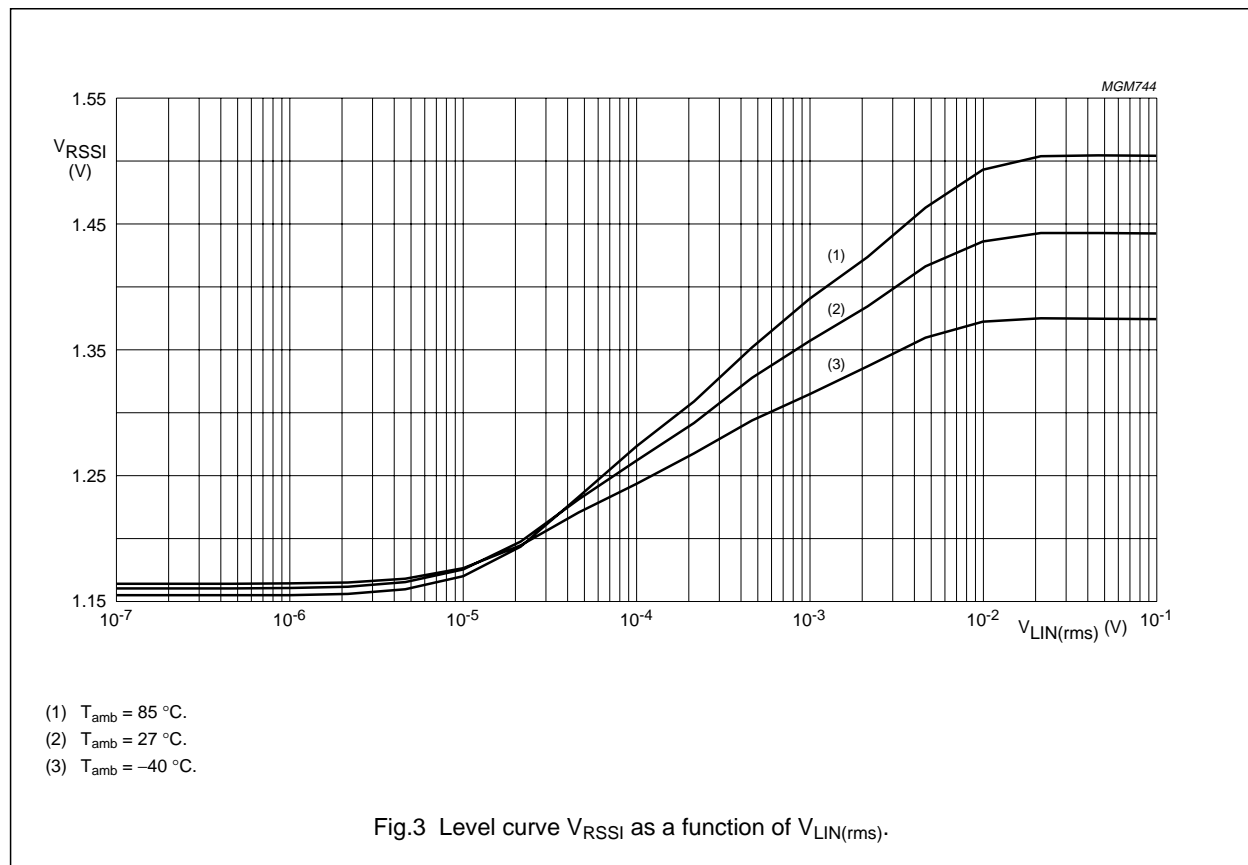

# Frequency Shift Keying (FSK)/Amplitude Shift Keying (ASK) receiver

UAA3220TS

## LIMITING VALUES

In accordance with the Absolute Maximum Rating System (IEC 134).

SYMBOL	PARAMETER	CONDITIONS	MIN.	MAX.	UNIT
$V_{CC}$	supply voltage		-0.3	+8.0	V
$P_{i(max)}$	absolute maximum input power		-	3	dBm
$T_{amb}$	operating ambient temperature		-40	+85	°C
$T_{stg}$	storage temperature		-55	+125	°C
$V_{es}$	electrostatic handling	note 1			
	pins 3 and 6		-50	+50	V
	pin 2		-100	+100	V
	pin 5		-250	+150	V
	pin 23		-200	+250	V
	all other pins		-250	+250	V

### Note

- Machine model:  $C = 200$  pF,  $R = 0$   $\Omega$  and  $L = 0.75$   $\mu$ H; pins are connected to GND and  $V_{CC}$ .

## THERMAL CHARACTERISTICS

SYMBOL	PARAMETER	CONDITIONS	VALUE	UNIT
$R_{th(j-a)}$	thermal resistance from junction to ambient	in free air	125	K/W

# Frequency Shift Keying (FSK)/Amplitude Shift Keying (ASK) receiver

UAA3220TS

**DC CHARACTERISTICS**

$V_{CC} = 2.7\text{ V}$ ;  $T_{amb} = 25\text{ °C}$ ; for application diagram see Figs 9 and 10; crystal disconnected; unless otherwise specified.

SYMBOL	PARAMETER	CONDITIONS	MIN.	TYP.	MAX.	UNIT
<b>Supplies</b>						
$V_{CC}$	supply voltage		2.7	–	5.5	V
$I_{CC}$	supply current	operating mode on; $V_{PVD} = 0\text{ V}$ ; notes 1 and 2				
		FSK demodulation; note 3	2.8	4.3	5.8	mA
		ASK demodulation; note 4	2.5	3.7	4.9	mA
		operating mode off; $V_{PVD} = V_{CC}$	–	3	30	$\mu\text{A}$
$V_{PVD}$	voltage on pin PWD	operating mode on (receiving mode)	0	–	300	mV
		operating mode off (sleep mode)	$V_{CC} - 0.3$	–	$V_{CC}$	V
$I_{PVD}$	current into pin PWD	operating mode on (receiving mode); $V_{PVD} = 0\text{ V}$	–30	–10	–3	$\mu\text{A}$
		operating mode off (sleep mode); $V_{PVD} = V_{CC}$	–	2	15	$\mu\text{A}$
<b>Oscillator</b>						
$V_{OSE}$	DC voltage at pin 2	independent of oscillator	0.33	0.38	0.43	V
$V_{OSB}$	DC voltage at pin 3	independent of oscillator	1.05	1.15	1.25	V
<b>Multiplier</b>						
$V_{TEM}$	DC voltage at pin 6	independent of oscillator	0.33	0.39	0.45	V
$V_{TN,TP}$	DC voltage at pins 7 and 8	independent of oscillator	2.01	2.21	2.41	V
<b>Mixer</b>						
$V_{MIXIN}$	DC voltage at pin 23	independent of oscillator	0.68	0.78	0.88	V
<b>Post mixer amplifier</b>						
$V_{FA}$	DC voltage at pin 22	independent of oscillator	1.10	1.25	1.40	V
<b>Limiter</b>						
$V_{LIN}$	DC voltage at pin 20	independent of oscillator	1.85	1.95	2.05	V
$V_{LFB}$	DC voltage at pin 19	independent of oscillator	1.85	1.95	2.05	V
$V_{RSSI}$	DC voltage at pin 18	independent of oscillator	1.00	1.16	1.32	V



# Frequency Shift Keying (FSK)/Amplitude Shift Keying (ASK) receiver

UAA3220TS

SYMBOL	PARAMETER	CONDITIONS	MIN.	TYP.	MAX.	UNIT
<b>Demodulator</b>						
$V_{\text{DEMO1,2}}$	DC voltage at pins 10 and 11	independent of oscillator; note 5	2.00	2.24	2.48	V
$V_{\text{DEMO1(ASK)}}$	DC voltage at pin 10 to switch in ASK mode		0	–	300	mV
<b>Data filter and slicer</b>						
$V_{\text{CPA,CPB,CPC}}$	DC voltage at pins 15, 16 and 17	ASK mode	1.27	1.42	1.57	V
		FSK mode; note 6	1.81	2.01	2.21	V
$V_{\text{OH(DATA)}}$	HIGH-level output voltage at pin 14	$I_{\text{DATA}} = -10 \mu\text{A}$	$V_{\text{CC}} - 0.5$	–	$V_{\text{CC}}$	V
$V_{\text{OL(DATA)}}$	LOW-level output voltage at pin 14	$I_{\text{DATA}} = 200 \mu\text{A}$	0	–	0.6	V

**Notes**

- For  $f_{\text{i(RF)}} = 868.35 \text{ MHz}$  all values + 0.6 mA.
- Crystal connected; oscillator and multiplier active.
- Pin DEMO1 connected to pin DEMO2 via tank circuit.
- Pin DEMO1 short circuited to ground.
- The given values are applicable for FSK reception mode. In ASK mode pin 10 is short circuited to ground.
- No modulation and  $f_{\text{IF}} = 10.7 \text{ MHz}$ .

# Frequency Shift Keying (FSK)/Amplitude Shift Keying (ASK) receiver

UAA3220TS

## AC CHARACTERISTICS

$V_{CC} = 2.7\text{ V}$ ;  $T_{amb} = 25\text{ °C}$ ; for application diagram see Figs 9 and 10;  $f_{i(RF)} = 433.92\text{ MHz}$  (see Table 4) and  $f_{i(RF)} = 868.35\text{ MHz}$  (see Table 5);  $f_{mod} = 1\text{ kHz}$  square wave; unless otherwise specified.

SYMBOL	PARAMETER	CONDITIONS	MIN.	TYP.	MAX.	UNIT
<b>System performance</b>						
$f_{i(RF)}$	RF input frequency		250	–	920	MHz
$f_{IF}$	IF frequency		10.56	10.7	10.84	MHz
$P_{i(max)}$	maximum input power		–	–	3	dBm
		ASK mode; BER $\leq$ 3%; notes 1 and 2	–22	–16	–10	dBm
		FSK mode; BER $\leq$ 3%; notes 2 and 3	–6	0	+1	dBm
$P_{SPUR}$	spurious radiation	note 4	–	–	–57	dBm
$f_{DATA}$	data frequency	note 5	–	1	–	kHz
$t_{on(RX)}$	receiver turn-on time	notes 6 and 7				
		$f_{i(RF)} = 433.92\text{ MHz}$	–	6	10	ms
		$f_{i(RF)} = 868.35\text{ MHz}$	–	3	7	ms
$V_{RSSI}$	RSSI voltage		1.1	–	1.6	V
<b>ASK mode</b>						
$\Phi_{i(ASK)}$	input sensitivity directly into pin MIXIN	BER $\leq$ 3%; notes 1 and 2				
		$f_{i(RF)} = 433.92\text{ MHz}$	–	–119	–113	dBm
		$f_{i(RF)} = 868.35\text{ MHz}$	–	–116	–110	dBm
<b>FSK mode</b>						
$\Phi_{i(FSK)}$	input sensitivity directly into pin MIXIN	BER $\leq$ 3%; notes 2 and 3	–	–103	–100	dBm
$\Delta f$	frequency deviation (peak value)		4	10	75	kHz
$\Delta\Phi_{(FSK)(max)}$	maximum sensitivity degradation	$\Delta f = 4\text{ kHz}$	–	–	3	dB
$G_{dem}$	demodulator gain	note 8	0.75	1.0	1.25	$\frac{mV}{kHz}$
<b>Mixer and post mixer amplifier</b>						
$Z_i$	input impedance of mixer	$f_{i(RF)} = 433.92\text{ MHz}$	–	600	–	$\Omega$
		$f_{i(RF)} = 868.35\text{ MHz}$	–	300	–	$\Omega$
$IP3_{PMA}$	interception point (mixer + PMA)		–38	–30	–	dBm
$G_{PMA}$	gain (mixer + PMA)	note 9	40	42	50	dB
$Z_{O(IF)}$	output impedance of IF amplifier		280	330	380	$\Omega$

# Frequency Shift Keying (FSK)/Amplitude Shift Keying (ASK) receiver

UAA3220TS

SYMBOL	PARAMETER	CONDITIONS	MIN.	TYP.	MAX.	UNIT
<b>Limiter</b>						
$R_{i(LIN)}$	limiter input resistance		40	48	56	k $\Omega$
<b>Buffer</b>						
$R_{CPC}$	data buffer output resistance at pin 17		24	30	36	k $\Omega$
$G_{buffer}$	data buffer AC gain		12	13	14	dB
$R_{CPA,CPB}$	data buffer output resistance at pins 15 and 16		120	150	180	k $\Omega$
<b>Data slicer</b> ; see Chapter "DC characteristics"						
$B_{ds}$	internal data slicer bandwidth		50	–	100	kHz

**Notes**

- 100% AM modulation (ASK); available power from generator into a 50  $\Omega$  load.
- With external matching network, to transform the impedance to 50  $\Omega$ .
- $\Delta f = 10$  kHz; available power from generator into a 50  $\Omega$  load.
- Measured at the RF input connector of the test board into a 50  $\Omega$  load;  $f_{i(RF)} = 25$  MHz to 1 GHz.
- The data frequency range can be varied by changing C30 to C32 (see Figs 9 and 10) to match other bit rates. Data frequency determined by data slicer application.
- $t_{on} = 50$  ms;  $t_{off} = 138$  ms;  $P = P_{sens} + 3$  dB.
- The given turn-on time is only valid during strobing by pin PWD; if the IC is strobed on and off by the supply voltage the turn-on time will be longer.
- LC tank circuit (L60, C60) tuned to maximum phase slope.
- $G_{PMA}$  is typically 6 dB lower when measured in the application, because of the load of the ceramic filter.

# Frequency Shift Keying (FSK)/Amplitude Shift Keying (ASK) receiver

UAA3220TS

## INTERNAL CIRCUITRY

**Table 1** Equivalent pin circuits and pin voltages for rough test of printed-circuit board;  $V_{CC} = 2.7$  V; no input signal

PIN NO.	PIN SYMBOL	DC VOLTAGE (V)	EQUIVALENT CIRCUIT
1	OGND	0	<p>MHA780</p>
2	OSE	0.38	
3	OSB	1.15	
5	OSC	2.7	
4	$V_{CC}$	2.7	<p>MHA781</p>
6	TEM	0.39	
7	TN	2.21	
8	TP	2.21	
9	PWD	—	<p>MGM750</p>
10	DEMO1	2.24	<p>MGM751</p>
11	DEMO2	2.24	
12	GND	0	

Frequency Shift Keying (FSK)/Amplitude Shift Keying (ASK) receiver

UAA3220TS

PIN NO.	PIN SYMBOL	DC VOLTAGE (V)	EQUIVALENT CIRCUIT
13	CGND	0	
15	CPA	1.95	
16	CPB	1.95	
14	DATA	—	
17	CPC	1.95	
18	RSSI	1.16	

Frequency Shift Keying (FSK)/Amplitude Shift Keying (ASK) receiver

UAA3220TS

PIN NO.	PIN SYMBOL	DC VOLTAGE (V)	EQUIVALENT CIRCUIT
19	LFB	1.95	
20	LIN	1.95	
21	V <sub>CCI</sub>	2.7	
22	FA	1.25	
23	MIXIN	0.78	
24	MGND	0	

# Frequency Shift Keying (FSK)/Amplitude Shift Keying (ASK) receiver

UAA3220TS

## TEST INFORMATION

### Tuning procedures

#### TUNING PROCEDURE FOR AC TESTS

1. Turn on the signal generator ( $f_{i(RF)} = 433.92$  or  $868.35$  MHz; no modulation; RF input level =  $-50$  dBm).
2. Tune first C50 (multiplier tank circuit), second C11 (RF stage input) to obtain a peak IF voltage at pin FA.

#### TUNING PROCEDURE FOR ASK RECEPTION

1. Make sure that pin DEMO1 is short circuited to ground.
2. Turn on ASK modulation and check that data is appearing on the DATA output pin and proceed with the AC tests.

#### TUNING PROCEDURE FOR FSK RECEPTION

1. Make sure that pins DEMO1 and DEMO2 are connected by the LC tank circuit.
2. Turn on FSK modulation ( $\Delta f = 10$  kHz; RF input level =  $-103$  dBm).
3. Tune C61 (or L60) (phase shifter LC tank circuit) to obtain a peak LF voltage at pin CPC.
4. Check that data is appearing on pin DATA and proceed with the AC tests.

### AC test conditions

**Table 2** Test signals

The reference signal level  $P_{ref}$  for the following tests is defined as the minimum input level in dBm to give a  $BER \leq 3 \times 10^{-2}$  (e.g. 60 bit errors per second for 2000 bits/s). All test signal levels refer to  $50 \Omega$  load condition.

TEST SIGNAL	FREQUENCY (MHz)	DATA SIGNAL	MODULATION	MODULATION INDEX	FREQUENCY DEVIATION
1	433.92/868.35	1000 Hz square wave	AM (ASK)	100%	–
2	433.92/868.35	1000 Hz square wave	FM (FSK)	–	10 kHz
3	433.92/868.35	–	no modulation	–	–
4	433.82/868.35	–	no modulation	–	–

# Frequency Shift Keying (FSK)/Amplitude Shift Keying (ASK) receiver

UAA3220TS

**Table 3** Tests and results

$P_1$  is the maximum available power from signal generator 1 at the input of the test board;  $P_2$  is the maximum available power from signal generator 2 at the input of the test board.

TEST	GENERATOR		RESULT
	1	2	
ASK sensitivity into pin MIXIN (see Fig.5)	modulated test signal 1; $P_1 \leq -113$ dBm for $f_{i(RF)} = 433.92$ MHz; $P_1 \leq -110$ dBm for $f_{i(RF)} = 868.35$ MHz	–	$BER \leq 3 \times 10^{-2}$ (e.g. 60 bit errors per second for 2000 bits/s)
FSK sensitivity into pin MIXIN (see Fig.5)	modulated test signal 2; $P_1 \leq -100$ dBm	–	$BER \leq 3 \times 10^{-2}$ (e.g. 60 bit errors per second for 2000 bits/s)
Maximum input power for ASK (see Fig.5)	modulated test signal 1; $P_1 \geq -22$ dBm	–	$BER \leq 3 \times 10^{-2}$ (e.g. 60 bit errors per second for 2000 bits/s)
Maximum input power for FSK (see Fig.5)	modulated test signal 2; $P_1 \geq -6$ dBm	–	$BER \leq 3 \times 10^{-2}$ (e.g. 60 bit errors per second for 2000 bits/s)
Receiver turn-on time; see note 1 and Fig.4	modulated test signal 1 or 2; $P_1 = P_{ref} + 3$ dB	–	check that the first 10 bits are correct; error counting is started 10 ms after power down is switched into operating mode on
Interception point (mixer + PMA) see note 2 and Fig.6	test signal 3; $P_1 = -40$ dBm	test signal 4; $P_2 = P_1$	measure with high impedance probe at pin FA $IP3_{PMA} = P_1 + \frac{IM3}{2}$ dBm (for IM3 see Fig.6)
Spurious radiation; see note 3 and Fig.7	–	–	no spurious signals (25 MHz to 1 GHz) with level higher than maximum $P_{SPUR}$

**Notes**

1. The voltage at pin PWD of the test circuit alternates between operating mode: on (50 ms; 0 V) and off (138 ms;  $V_{CC}$ ); see Fig.4.
2. Probe of spectrum analyzer connected to pin FA (pin 22).
3. Spectrum analyzer connected to the input of the test board.

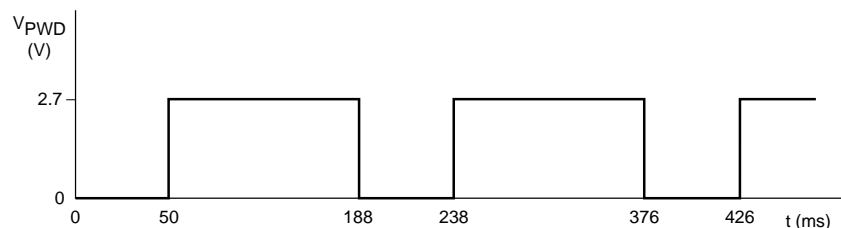

MGM745

Fig.4 Timing diagram for pulsed power down voltage.



Frequency Shift Keying (FSK)/Amplitude Shift Keying (ASK) receiver

UAA3220TS

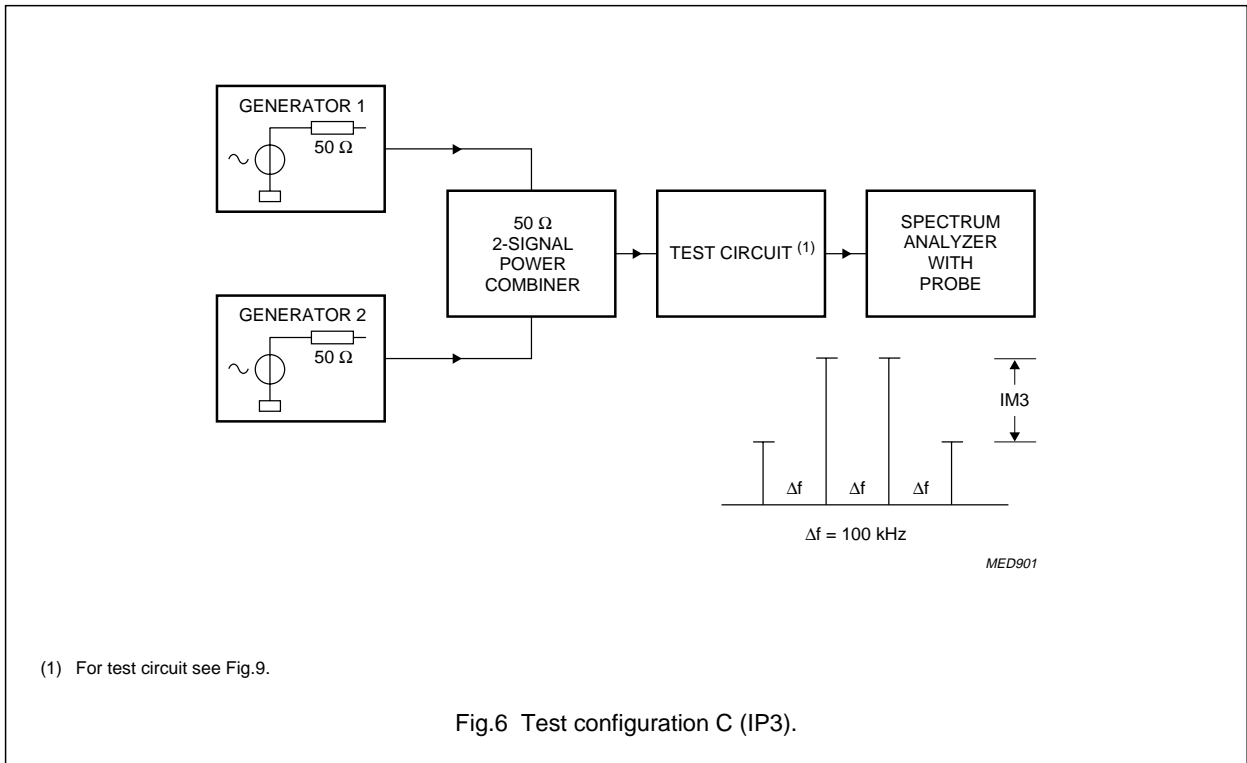
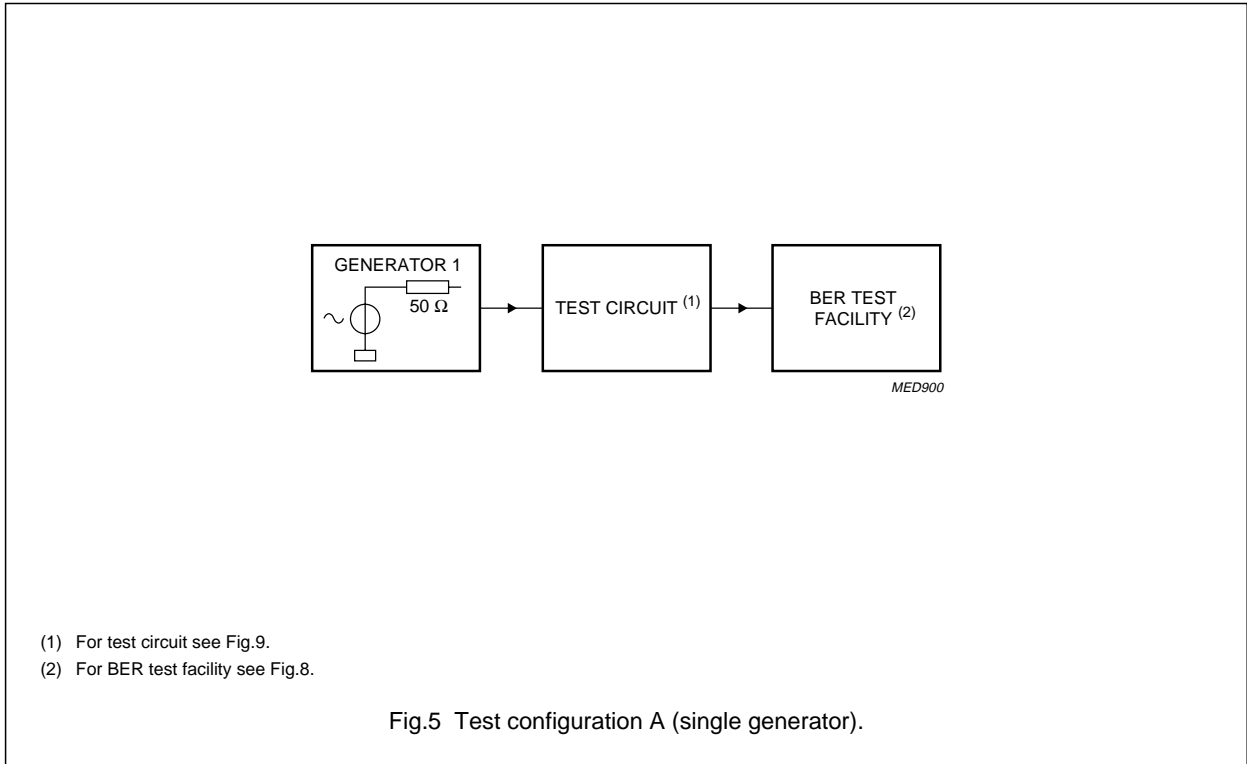

Frequency Shift Keying (FSK)/Amplitude Shift Keying (ASK) receiver

UAA3220TS

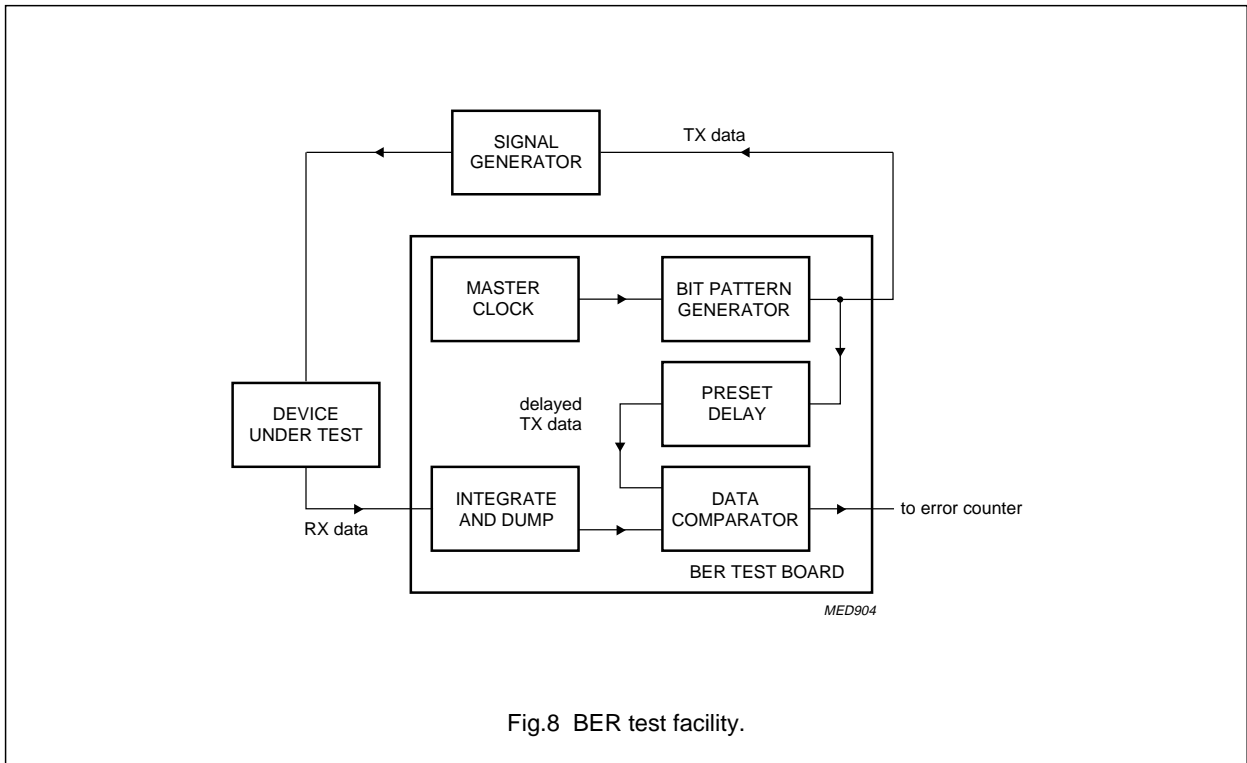
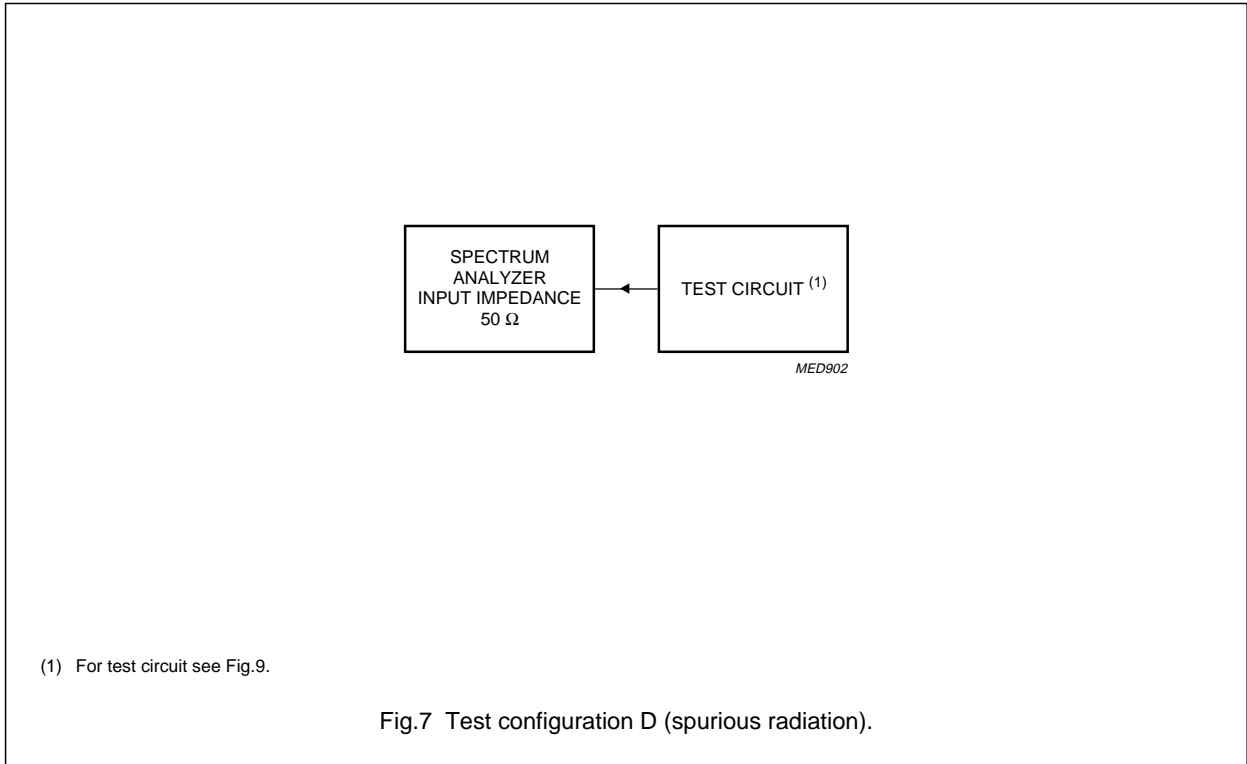

Frequency Shift Keying (FSK)/Amplitude Shift Keying (ASK) receiver

UAA3220TS

APPLICATION INFORMATION

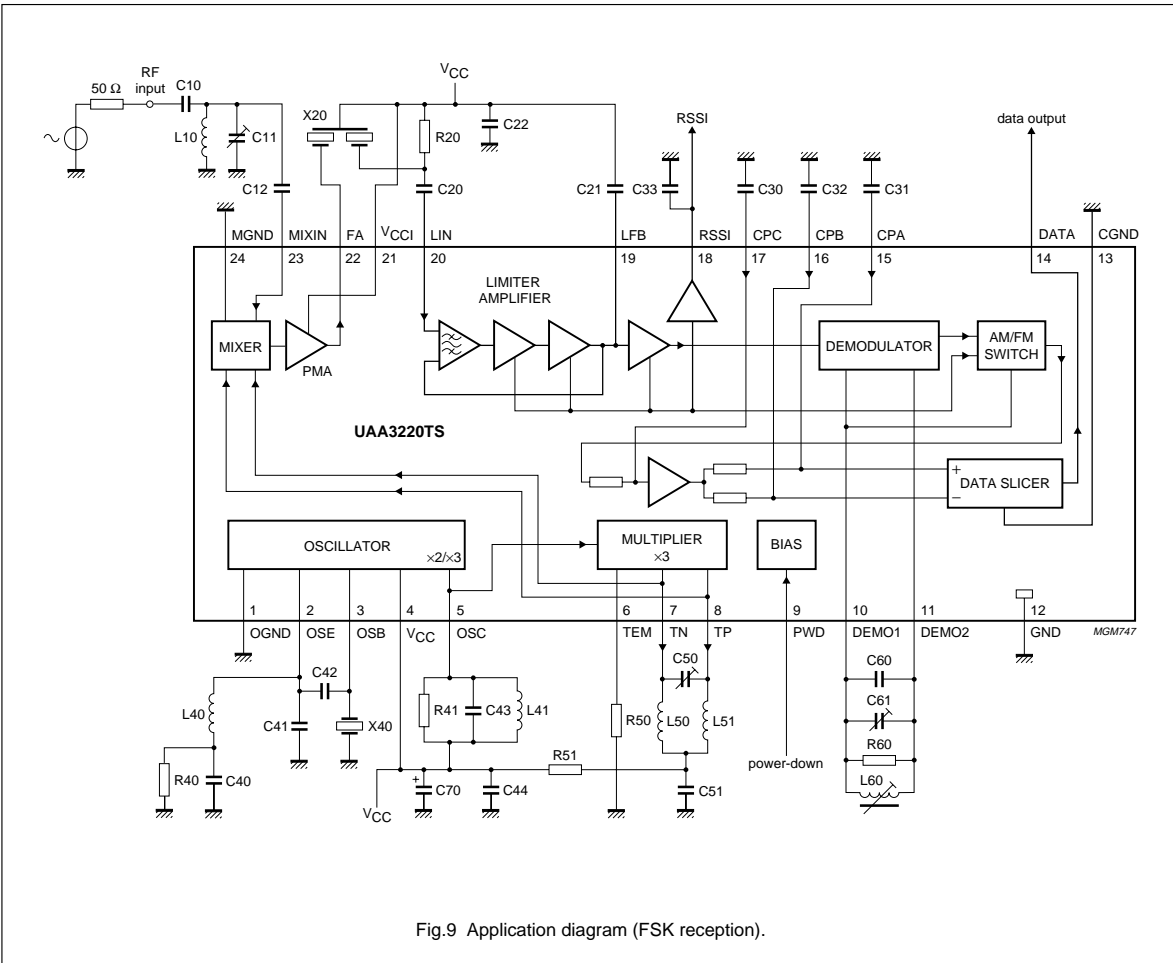

Fig.9 Application diagram (FSK reception).

### Frequency Shift Keying (FSK)/Amplitude Shift Keying (ASK) receiver

### UAA3220TS

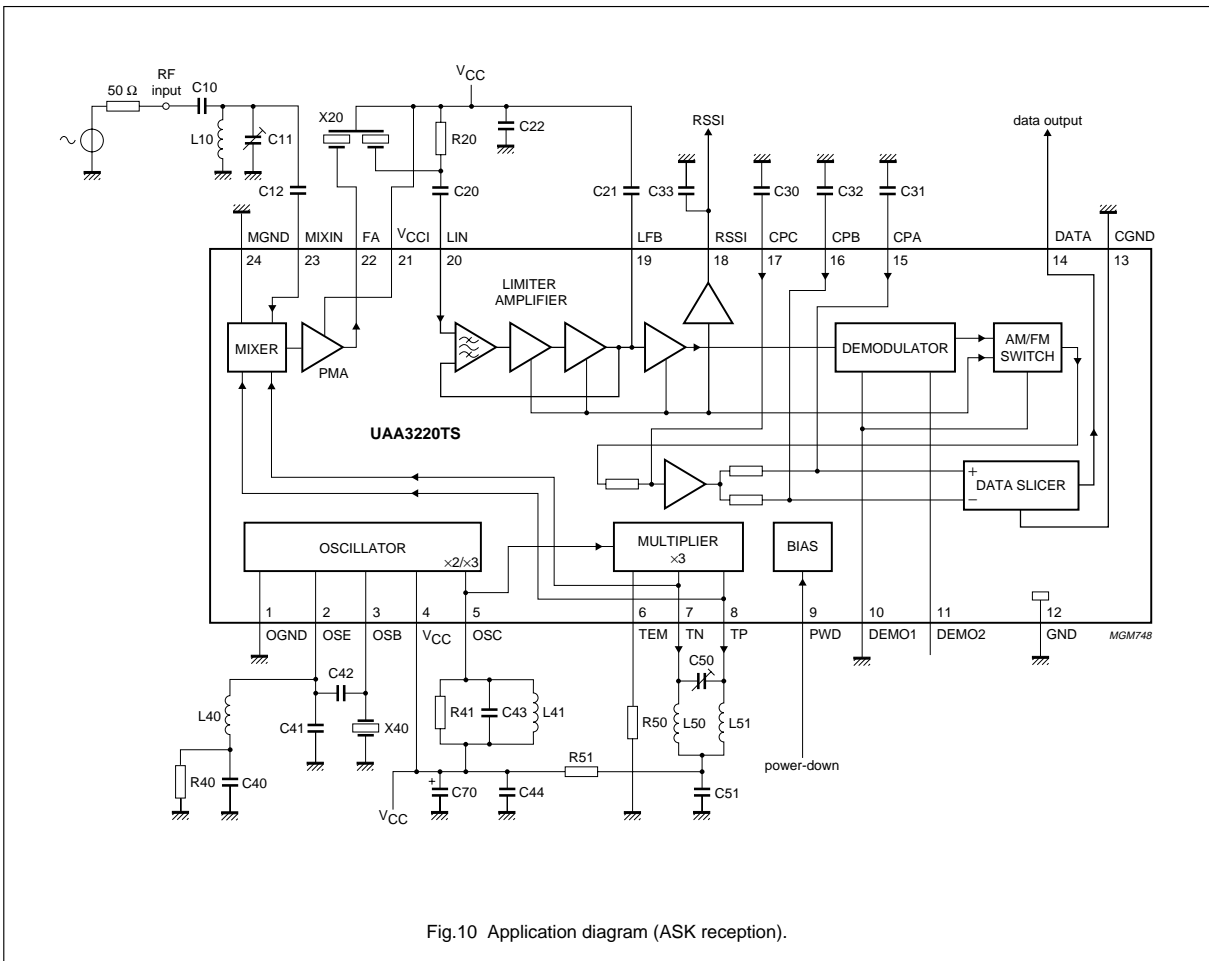

Fig.10 Application diagram (ASK reception).

# Frequency Shift Keying (FSK)/Amplitude Shift Keying (ASK) receiver

UAA3220TS

**Table 4** Component list for Figs 9 and 10;  $f_{i(RF)} = 433.92$  MHz

COMPONENT	COMPONENT CHARACTERISTICS					
	VALUE	TOLERANCE	TEMPERATURE COEFFICIENT (ppm/K)	LOSS FACTOR AT 1 MHz	QUALITY FACTOR	SELF RESONANCE FREQUENCY
R20	330 $\Omega$	$\pm 2\%$	+50	–	–	–
R40	1.8 k $\Omega$	$\pm 2\%$	+50	–	–	–
R41	not placed	–	–	–	–	–
R50	1.2 k $\Omega$	$\pm 2\%$	+50	–	–	–
R51	1.5 k $\Omega$	$\pm 2\%$	+50	–	–	–
R60	4.7 k $\Omega$	$\pm 2\%$	+50	–	–	–
C10 <sup>(1)</sup>	2.7 pF	$\pm 10\%$	0 $\pm 30$	$\tan \delta \leq 20 \times 10^{-4}$	–	–
C11	3 to 10 pF	–	0 $\pm 300$	$\tan \delta \leq 20 \times 10^{-4}$	–	–
C12	100 pF	$\pm 10\%$	0 $\pm 30$	$\tan \delta \leq 10 \times 10^{-4}$	–	–
C20	1 nF	$\pm 10\%$	0 $\pm 30$	$\tan \delta \leq 10 \times 10^{-4}$	–	–
C21	47 nF	$\pm 10\%$	0 $\pm 30$	$\tan \delta \leq 10 \times 10^{-4}$	–	–
C22	1 nF	$\pm 10\%$	0 $\pm 30$	$\tan \delta \leq 10 \times 10^{-4}$	–	–
C30	2.7 nF	$\pm 10\%$	0 $\pm 30$	$\tan \delta \leq 10 \times 10^{-4}$	–	–
C31	470 pF	$\pm 10\%$	0 $\pm 30$	$\tan \delta \leq 10 \times 10^{-4}$	–	–
C32	47 nF	$\pm 10\%$	0 $\pm 30$	$\tan \delta \leq 10 \times 10^{-4}$	–	–
C33	10 nF	$\pm 10\%$	0 $\pm 30$	$\tan \delta \leq 10 \times 10^{-4}$	–	–
C40	1 nF	$\pm 10\%$	0 $\pm 30$	$\tan \delta \leq 20 \times 10^{-4}$	–	–
C41 <sup>(1)</sup>	15 pF	$\pm 10\%$	0 $\pm 30$	$\tan \delta \leq 20 \times 10^{-4}$	–	–
C42	15 pF	$\pm 10\%$	0 $\pm 30$	$\tan \delta \leq 10 \times 10^{-4}$	–	–
C43 <sup>(1)</sup>	8.2 pF	$\pm 10\%$	0 $\pm 30$	$\tan \delta \leq 20 \times 10^{-4}$	–	–
C44	1 nF	$\pm 10\%$	0 $\pm 30$	$\tan \delta \leq 10 \times 10^{-4}$	–	–
C50	3 to 10 pF	–	0 $\pm 300$	$\tan \delta \leq 20 \times 10^{-4}$	–	–
C51	1 nF	$\pm 10\%$	0 $\pm 30$	$\tan \delta \leq 10 \times 10^{-4}$	–	–
C60 <sup>(2)</sup>	82 pF	$\pm 10\%$	0 $\pm 30$	$\tan \delta \leq 10 \times 10^{-4}$	–	–
C61 <sup>(2)</sup>	5 to 30 pF	–	0 $\pm 300$	$\tan \delta \leq 10 \times 10^{-4}$	–	–
C70	not placed	–	–	–	–	–
L10 <sup>(3)</sup>	8 nH	$\pm 5\%$	+25 to +125	–	$\geq 140$ at 150 MHz	$\geq 3$ GHz
L40	560 nH	$\pm 10\%$	+25 to +125	–	$\geq 45$ at 100 MHz	$\geq 400$ MHz
L41	100 nH	$\pm 10\%$	+25 to +125	–	$\geq 60$ at 350 MHz	$\geq 1$ GHz
L50 <sup>(3)</sup>	8 nH	$\pm 5\%$	+25 to +125	–	$\geq 140$ at 150 MHz	$\geq 3$ GHz
L51 <sup>(3)</sup>	8 nH	$\pm 5\%$	+25 to +125	–	$\geq 140$ at 150 MHz	$\geq 3$ GHz
L60 <sup>(2)</sup>	2.2 $\mu$ H	$\pm 10\%$	+25 to +125	–	$\geq 37$ at 7.9 MHz	$\geq 150$ MHz
X20	ceramic filter, Murata SFE 10.7 MA 5 A; see note 4					
X40	3rd overtone crystal, 70.5367 MHz; see note 5					

---

**Frequency Shift Keying (FSK)/Amplitude  
Shift Keying (ASK) receiver**

---

UAA3220TS

**Notes**

1. C10, C41 and C43 can be placed as tuning capacitors on the PCB.
2. C60, C61 and L60 can be substituted by an LC tank.
3. L10, L50 and L51 are 3 turn air coils.
4. 3 dB bandwidth:  $280 \pm 50$  kHz; insertion loss: 4 dB typical and 6 dB maximum; spurious: 30 dB minimum at 8 to 12 MHz; input and output impedance:  $330 \Omega$ .
5. Motional resistance:  $R_m \leq 20 \Omega$ ; static capacitance:  $C_0 \leq 6$  pF; load capacitance:  $C_L = 6$  pF; loaded parallel resonance frequency: 70.5367 MHz; drive level dependency:  $R_m \leq 20 \Omega$  ( $1 \text{ nW} \leq P \leq 1 \text{ mW}$ ).

# Frequency Shift Keying (FSK)/Amplitude Shift Keying (ASK) receiver

UAA3220TS

**Table 5** Component list for Figs 9 and 10;  $f_{i(RF)} = 868.35$  MHz

COMPONENT	COMPONENT CHARACTERISTICS					
	VALUE	TOLERANCE	TEMPERATURE COEFFICIENT (ppm/K)	LOSS FACTOR AT 1 MHz	QUALITY FACTOR	SELF RESONANCE FREQUENCY
R20	330 $\Omega$	$\pm 5\%$	$\leq \pm 100$	–	–	–
R40	1.5 k $\Omega$	$\pm 5\%$	$\leq \pm 100$	–	–	–
R41	not placed	–	–	–	–	–
R50	390 $\Omega$	$\pm 5\%$	$\leq \pm 100$	–	–	–
R51	330 $\Omega$	$\pm 5\%$	$\leq \pm 100$	–	–	–
R60	4.7 k $\Omega$	$\pm 5\%$	$\leq \pm 100$	–	–	–
C10	27 pF	$\pm 5\%$	0 $\pm 30$	$\tan \delta \leq 10 \times 10^{-4}$	–	–
C11	1.7 to 3 pF	–	0 $\pm 300$	$\tan \delta \leq 20 \times 10^{-4}$	–	–
C12	27 pF	$\pm 5\%$	0 $\pm 30$	$\tan \delta \leq 10 \times 10^{-4}$	–	–
C20	1 nF	$\pm 10\%$	$\pm 15\%$ <sup>(1)</sup>	$\tan \delta \leq 2.5\%$	–	–
C21	47 nF	$\pm 10\%$	$\pm 15\%$ <sup>(1)</sup>	$\tan \delta \leq 2.5\%$	–	–
C22	1 nF	$\pm 10\%$	$\pm 15\%$ <sup>(1)</sup>	$\tan \delta \leq 2.5\%$	–	–
C30	3.3 nF	$\pm 10\%$	$\pm 15\%$ <sup>(1)</sup>	$\tan \delta \leq 2.5\%$	–	–
C31	680 pF	$\pm 10\%$	$\pm 15\%$ <sup>(1)</sup>	$\tan \delta \leq 2.5\%$	–	–
C32	10 nF	$\pm 10\%$	$\pm 15\%$ <sup>(1)</sup>	$\tan \delta \leq 2.5\%$	–	–
C33	10 nF	$\pm 10\%$	$\pm 15\%$ <sup>(1)</sup>	$\tan \delta \leq 2.5\%$	–	–
C40	1 nF	$\pm 10\%$	$\pm 15\%$ <sup>(1)</sup>	$\tan \delta \leq 2.5\%$	–	–
C41	12 pF	$\pm 5\%$	0 $\pm 30$	$\tan \delta \leq 10 \times 10^{-4}$	–	–
C42	12 pF	$\pm 5\%$	0 $\pm 30$	$\tan \delta \leq 10 \times 10^{-4}$	–	–
C43	4 pF	$\pm 0.25$ pF	0 $\pm 30$	$\tan \delta \leq 15 \times 10^{-4}$	–	–
C44	47 pF	$\pm 5\%$	0 $\pm 30$	$\tan \delta \leq 10 \times 10^{-4}$	–	–
C50	2.5 to 6 pF	–	0 $\pm 300$	$\tan \delta \leq 20 \times 10^{-4}$	–	–
C51	47 pF	$\pm 5\%$	0 $\pm 30$	$\tan \delta \leq 10 \times 10^{-4}$	–	–
C60 <sup>(2)</sup>	82 pF	$\pm 5\%$	0 $\pm 30$	$\tan \delta \leq 10 \times 10^{-4}$	–	–
C61 <sup>(2)</sup>	5 to 30 pF	–	0 $\pm 300$	$\tan \delta \leq 3.4 \times 10^{-4}$	–	–
C70	4.7 $\mu$ F	$\pm 20\%$	$\pm 15\%$ <sup>(1)</sup>	$\tan \delta \leq 0.06$	–	–
L10 <sup>(3)</sup>	–	–	–	–	–	–
L40	560 nH	$\pm 10\%$	+25 to +125	–	$\geq 30$ at 25 MHz	$\geq 415$ MHz
L41	39 nH	$\pm 10\%$	+25 to +125	–	$\geq 50$ at 50 MHz	$\geq 1.5$ GHz
L50 <sup>(3)</sup>	–	–	–	–	–	–
L51 <sup>(3)</sup>	–	–	–	–	–	–
L60 <sup>(2)</sup>	2.2 $\mu$ H	$\pm 10\%$	+25 to +125	–	$\geq 20$ at 7.9 MHz	$\geq 140$ MHz
X20	ceramic filter, Murata SFE 107 MA 5 A; see note 4					
X40	3rd overtone crystal, 95.2944 MHz; see note 5					

---

**Frequency Shift Keying (FSK)/Amplitude  
Shift Keying (ASK) receiver**

---

UAA3220TS

**Notes**

1. Temperature coefficient given as maximum  $\Delta C/C$  over temperature range.
2. C60, C61 and L60 can be substituted by an LC tank.
3. Realized as microstrip line; see Fig.12.
4. 3 dB bandwidth:  $280 \pm 50$  kHz; insertion loss: 4 dB typical and 6 dB maximum; spurious: 30 dB minimum at 8 to 12 MHz; input and output impedance:  $330 \Omega$ .
5. Motional resistance:  $R_m \leq 20 \Omega$ ; static capacitance:  $C_0 \leq 6$  pF; load capacitance:  $C_L = 6$  pF; loaded parallel resonance frequency: 95.2944 MHz; drive level dependency:  $R_m \leq 20 \Omega$  ( $1 \text{ nW} \leq P \leq 1 \text{ mW}$ ).



Frequency Shift Keying (FSK)/Amplitude Shift Keying (ASK) receiver

UAA3220TS

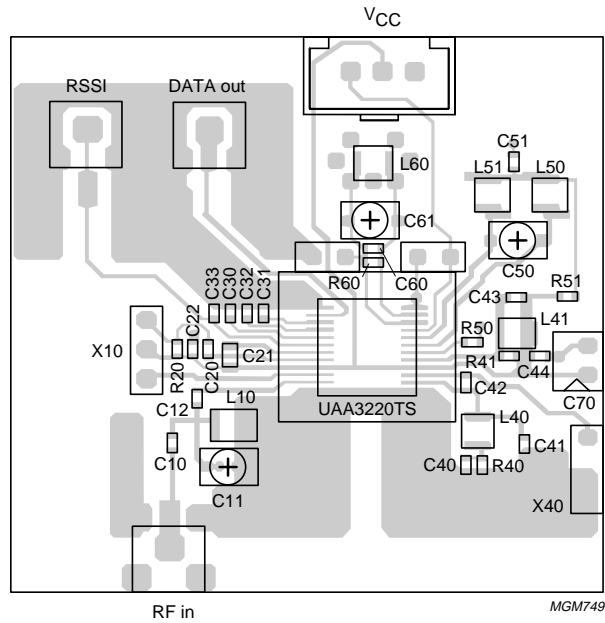
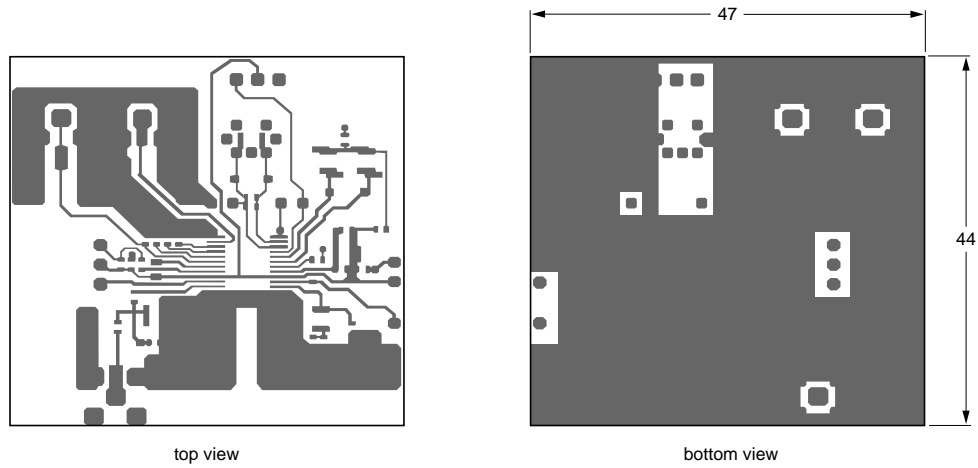

Dimensions in mm.

Fig.11 Printed-circuit board layout for  $f_{i(RF)} = 433.92$  MHz.

Frequency Shift Keying (FSK)/Amplitude Shift Keying (ASK) receiver

UAA3220TS

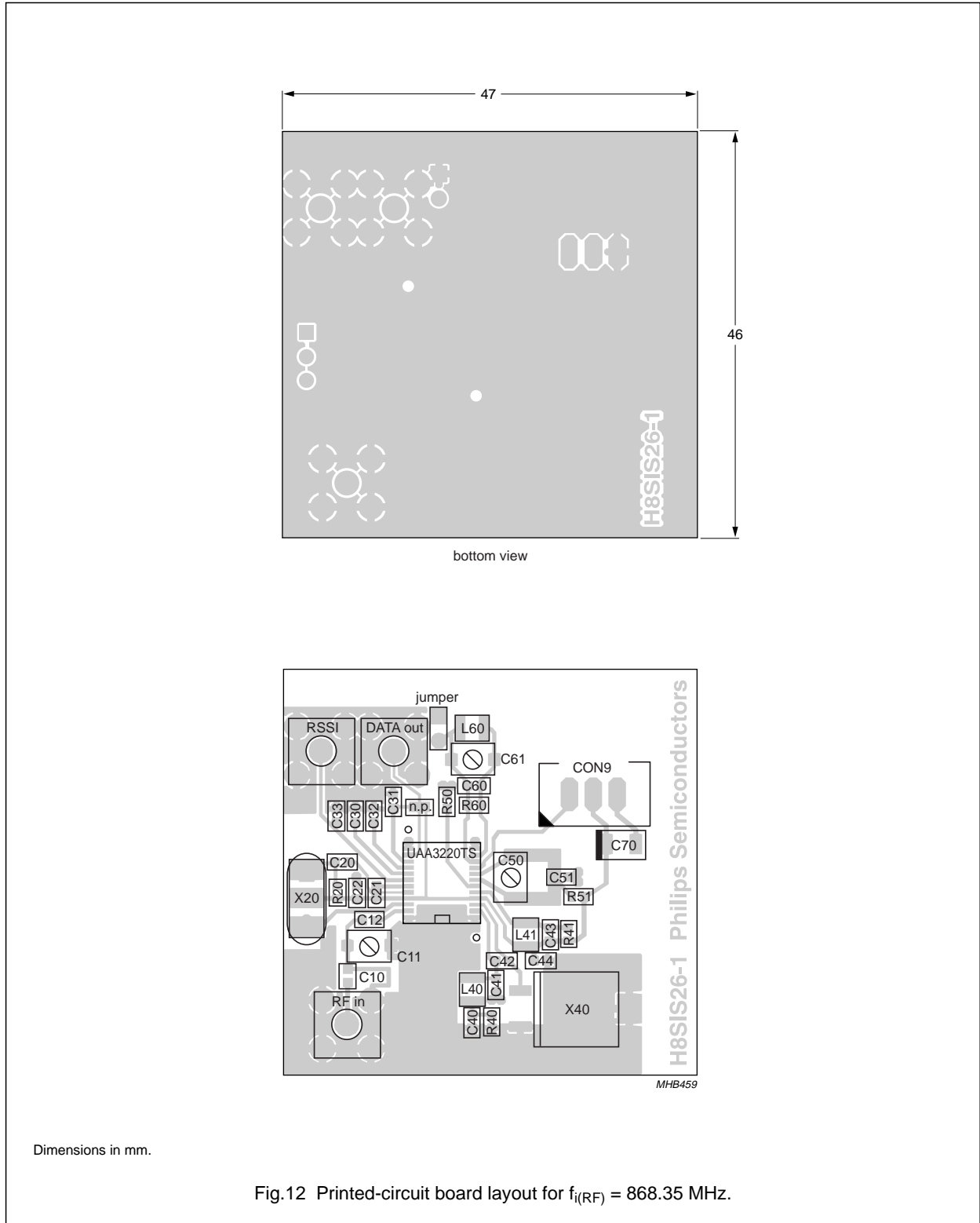

Frequency Shift Keying (FSK)/Amplitude Shift Keying (ASK) receiver

UAA3220TS

PACKAGE OUTLINE

SSOP24: plastic shrink small outline package; 24 leads; body width 5.3 mm

SOT340-1

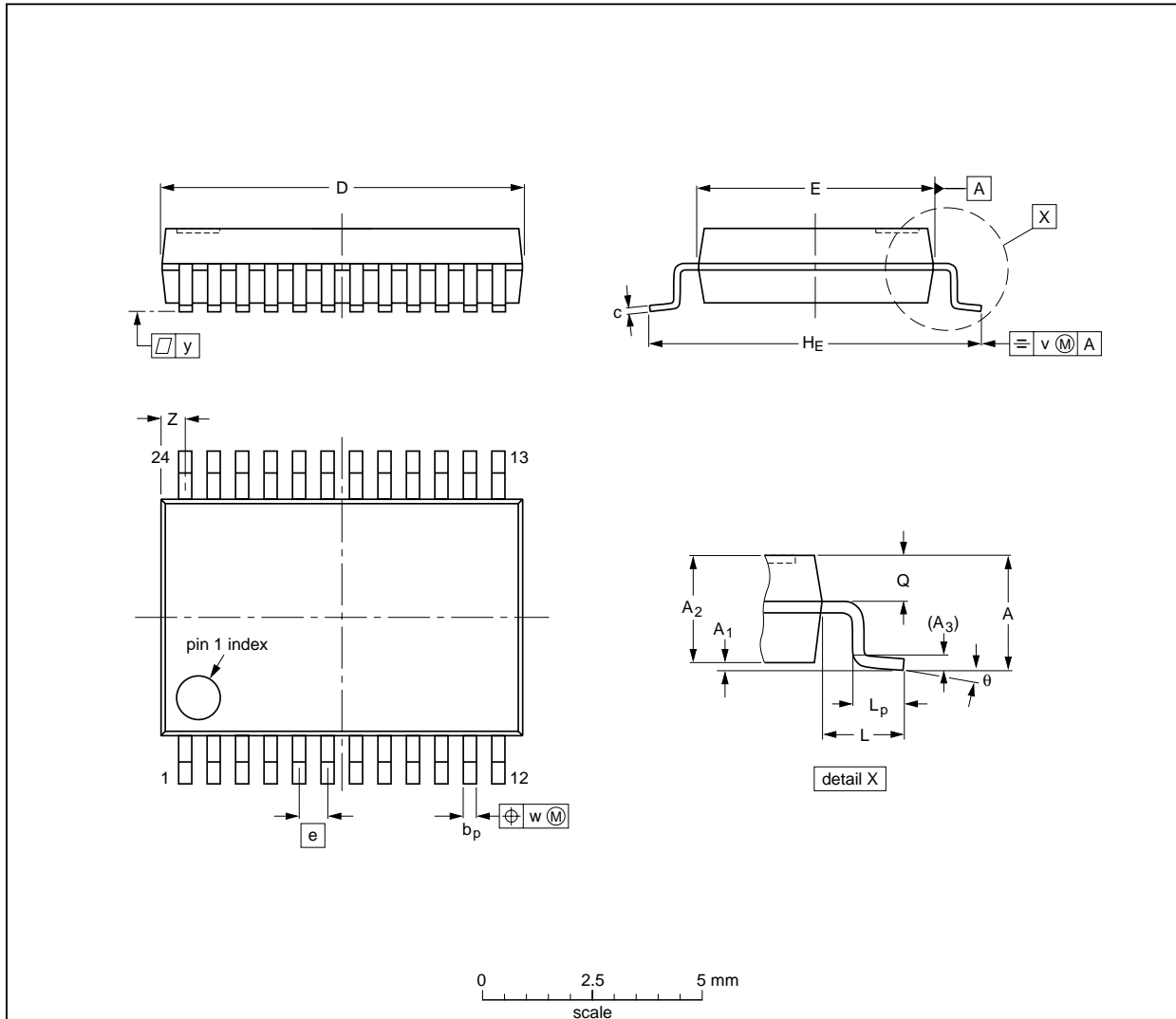

DIMENSIONS (mm are the original dimensions)

UNIT	A max.	A <sub>1</sub>	A <sub>2</sub>	A <sub>3</sub>	b <sub>p</sub>	c	D <sup>(1)</sup>	E <sup>(1)</sup>	e	H <sub>E</sub>	L	L <sub>p</sub>	Q	v	w	y	Z <sup>(1)</sup>	θ
mm	2.0	0.21 0.05	1.80 1.65	0.25	0.38 0.25	0.20 0.09	8.4 8.0	5.4 5.2	0.65	7.9 7.6	1.25	1.03 0.63	0.9 0.7	0.2	0.13	0.1	0.8 0.4	8° 0°

Note

1. Plastic or metal protrusions of 0.20 mm maximum per side are not included.

OUTLINE VERSION	REFERENCES				EUROPEAN PROJECTION	ISSUE DATE
	IEC	JEDEC	EIAJ			
SOT340-1		MO-150AG				93-09-08 95-02-04

## Frequency Shift Keying (FSK)/Amplitude Shift Keying (ASK) receiver

UAA3220TS

### SOLDERING

#### Introduction to soldering surface mount packages

This text gives a very brief insight to a complex technology. A more in-depth account of soldering ICs can be found in our "*Data Handbook IC26; Integrated Circuit Packages*" (document order number 9398 652 90011).

There is no soldering method that is ideal for all surface mount IC packages. Wave soldering is not always suitable for surface mount ICs, or for printed-circuit boards with high population densities. In these situations reflow soldering is often used.

#### Reflow soldering

Reflow soldering requires solder paste (a suspension of fine solder particles, flux and binding agent) to be applied to the printed-circuit board by screen printing, stencilling or pressure-syringe dispensing before package placement.

Several methods exist for reflowing; for example, infrared/convection heating in a conveyor type oven. Throughput times (preheating, soldering and cooling) vary between 100 and 200 seconds depending on heating method.

Typical reflow peak temperatures range from 215 to 250 °C. The top-surface temperature of the packages should preferably be kept below 230 °C.

#### Wave soldering

Conventional single wave soldering is not recommended for surface mount devices (SMDs) or printed-circuit boards with a high component density, as solder bridging and non-wetting can present major problems.

To overcome these problems the double-wave soldering method was specifically developed.

If wave soldering is used the following conditions must be observed for optimal results:

- Use a double-wave soldering method comprising a turbulent wave with high upward pressure followed by a smooth laminar wave.
- For packages with leads on two sides and a pitch (e):
  - larger than or equal to 1.27 mm, the footprint longitudinal axis is **preferred** to be parallel to the transport direction of the printed-circuit board;
  - smaller than 1.27 mm, the footprint longitudinal axis **must** be parallel to the transport direction of the printed-circuit board.

The footprint must incorporate solder thieves at the downstream end.

- For packages with leads on four sides, the footprint must be placed at a 45° angle to the transport direction of the printed-circuit board. The footprint must incorporate solder thieves downstream and at the side corners.

During placement and before soldering, the package must be fixed with a droplet of adhesive. The adhesive can be applied by screen printing, pin transfer or syringe dispensing. The package can be soldered after the adhesive is cured.

Typical dwell time is 4 seconds at 250 °C.

A mildly-activated flux will eliminate the need for removal of corrosive residues in most applications.

#### Manual soldering

Fix the component by first soldering two diagonally-opposite end leads. Use a low voltage (24 V or less) soldering iron applied to the flat part of the lead. Contact time must be limited to 10 seconds at up to 300 °C.

When using a dedicated tool, all other leads can be soldered in one operation within 2 to 5 seconds between 270 and 320 °C.

# Frequency Shift Keying (FSK)/Amplitude Shift Keying (ASK) receiver

UAA3220TS

## Suitability of surface mount IC packages for wave and reflow soldering methods

PACKAGE	SOLDERING METHOD	
	WAVE	REFLOW <sup>(1)</sup>
BGA, SQFP	not suitable	suitable
HLQFP, HSQFP, HSOP, HTSSOP, SMS	not suitable <sup>(2)</sup>	suitable
PLCC <sup>(3)</sup> , SO, SOJ	suitable	suitable
LQFP, QFP, TQFP	not recommended <sup>(3)(4)</sup>	suitable
SSOP, TSSOP, VSO	not recommended <sup>(5)</sup>	suitable

### Notes

1. All surface mount (SMD) packages are moisture sensitive. Depending upon the moisture content, the maximum temperature (with respect to time) and body size of the package, there is a risk that internal or external package cracks may occur due to vaporization of the moisture in them (the so called popcorn effect). For details, refer to the Drypack information in the "Data Handbook IC26; Integrated Circuit Packages; Section: Packing Methods".
2. These packages are not suitable for wave soldering as a solder joint between the printed-circuit board and heatsink (at bottom version) can not be achieved, and as solder may stick to the heatsink (on top version).
3. If wave soldering is considered, then the package must be placed at a 45° angle to the solder wave direction. The package footprint must incorporate solder thieves downstream and at the side corners.
4. Wave soldering is only suitable for LQFP, TQFP and QFP packages with a pitch (e) equal to or larger than 0.8 mm; it is definitely not suitable for packages with a pitch (e) equal to or smaller than 0.65 mm.
5. Wave soldering is only suitable for SSOP and TSSOP packages with a pitch (e) equal to or larger than 0.65 mm; it is definitely not suitable for packages with a pitch (e) equal to or smaller than 0.5 mm.

### DEFINITIONS

Data sheet status	
Objective specification	This data sheet contains target or goal specifications for product development.
Preliminary specification	This data sheet contains preliminary data; supplementary data may be published later.
Product specification	This data sheet contains final product specifications.
Limiting values	
Limiting values given are in accordance with the Absolute Maximum Rating System (IEC 134). Stress above one or more of the limiting values may cause permanent damage to the device. These are stress ratings only and operation of the device at these or at any other conditions above those given in the Characteristics sections of the specification is not implied. Exposure to limiting values for extended periods may affect device reliability.	
Application information	
Where application information is given, it is advisory and does not form part of the specification.	

### LIFE SUPPORT APPLICATIONS

These products are not designed for use in life support appliances, devices, or systems where malfunction of these products can reasonably be expected to result in personal injury. Philips customers using or selling these products for use in such applications do so at their own risk and agree to fully indemnify Philips for any damages resulting from such improper use or sale.

---

Frequency Shift Keying (FSK)/Amplitude  
Shift Keying (ASK) receiver

---

UAA3220TS

**NOTES**

---

Frequency Shift Keying (FSK)/Amplitude  
Shift Keying (ASK) receiver

---

UAA3220TS

**NOTES**

# Philips Semiconductors – a worldwide company

**Argentina:** see South America

**Australia:** 34 Waterloo Road, NORTH RYDE, NSW 2113,  
Tel. +61 2 9805 4455, Fax. +61 2 9805 4466

**Austria:** Computerstr. 6, A-1101 WIEN, P.O. Box 213,  
Tel. +43 1 60 101 1248, Fax. +43 1 60 101 1210

**Belarus:** Hotel Minsk Business Center, Bld. 3, r. 1211, Volodarski Str. 6,  
220050 MINSK, Tel. +375 172 20 0733, Fax. +375 172 20 0773

**Belgium:** see The Netherlands

**Brazil:** see South America

**Bulgaria:** Philips Bulgaria Ltd., Energoproject, 15th floor,  
51 James Bouchier Blvd., 1407 SOFIA,  
Tel. +359 2 68 9211, Fax. +359 2 68 9102

**Canada:** PHILIPS SEMICONDUCTORS/COMPONENTS,  
Tel. +1 800 234 7381, Fax. +1 800 943 0087

**China/Hong Kong:** 501 Hong Kong Industrial Technology Centre,  
72 Tat Chee Avenue, Kowloon Tong, HONG KONG,  
Tel. +852 2319 7888, Fax. +852 2319 7700

**Colombia:** see South America

**Czech Republic:** see Austria

**Denmark:** Sydhavnsgade 23, 1780 COPENHAGEN V,  
Tel. +45 33 29 3333, Fax. +45 33 29 3905

**Finland:** Sinikalliontie 3, FIN-02630 ESPOO,  
Tel. +358 9 615 800, Fax. +358 9 6158 0920

**France:** 51 Rue Carnot, BP317, 92156 SURESNES Cedex,  
Tel. +33 1 4099 6161, Fax. +33 1 4099 6427

**Germany:** Hammerbrookstraße 69, D-20097 HAMBURG,  
Tel. +49 40 2353 60, Fax. +49 40 2353 6300

**Greece:** No. 15, 25th March Street, GR 17778 TAVROS/ATHENS,  
Tel. +30 1 489 4339/4239, Fax. +30 1 481 4240

**Hungary:** see Austria

**India:** Philips INDIA Ltd, Band Box Building, 2nd floor,  
254-D, Dr. Annie Besant Road, Worli, MUMBAI 400 025,  
Tel. +91 22 493 8541, Fax. +91 22 493 0966

**Indonesia:** PT Philips Development Corporation, Semiconductors Division,  
Gedung Philips, Jl. Buncit Raya Kav.99-100, JAKARTA 12510,  
Tel. +62 21 794 0040 ext. 2501, Fax. +62 21 794 0080

**Ireland:** Newstead, Clonskeagh, DUBLIN 14,  
Tel. +353 1 7640 000, Fax. +353 1 7640 200

**Israel:** RAPAC Electronics, 7 Kehilat Saloniki St, PO Box 18053,  
TEL AVIV 61180, Tel. +972 3 645 0444, Fax. +972 3 649 1007

**Italy:** PHILIPS SEMICONDUCTORS, Piazza IV Novembre 3,  
20124 MILANO, Tel. +39 2 6752 2531, Fax. +39 2 6752 2557

**Japan:** Philips Bldg 13-37, Kohnan 2-chome, Minato-ku,  
TOKYO 108-8507, Tel. +81 3 3740 5130, Fax. +81 3 3740 5077

**Korea:** Philips House, 260-199 Itaewon-dong, Yongsan-ku, SEOUL,  
Tel. +82 2 709 1412, Fax. +82 2 709 1415

**Malaysia:** No. 76 Jalan Universiti, 46200 PETALING JAYA, SELANGOR,  
Tel. +60 3 750 5214, Fax. +60 3 757 4880

**Mexico:** 5900 Gateway East, Suite 200, EL PASO, TEXAS 79905,  
Tel. +9-5 800 234 7381, Fax +9-5 800 943 0087

**Middle East:** see Italy

**Netherlands:** Postbus 90050, 5600 PB EINDHOVEN, Bldg. VB,  
Tel. +31 40 27 82785, Fax. +31 40 27 88399

**New Zealand:** 2 Wagener Place, C.P.O. Box 1041, AUCKLAND,  
Tel. +64 9 849 4160, Fax. +64 9 849 7811

**Norway:** Box 1, Manglerud 0612, OSLO,  
Tel. +47 22 74 8000, Fax. +47 22 74 8341

**Pakistan:** see Singapore

**Philippines:** Philips Semiconductors Philippines Inc.,  
106 Valero St. Salcedo Village, P.O. Box 2108 MCC, MAKATI,  
Metro MANILA, Tel. +63 2 816 6380, Fax. +63 2 817 3474

**Poland:** Ul. Lukiska 10, PL 04-123 WARSZAWA,  
Tel. +48 22 612 2831, Fax. +48 22 612 2327

**Portugal:** see Spain

**Romania:** see Italy

**Russia:** Philips Russia, Ul. Usatcheva 35A, 119048 MOSCOW,  
Tel. +7 095 755 6918, Fax. +7 095 755 6919

**Singapore:** Lorong 1, Toa Payoh, SINGAPORE 319762,  
Tel. +65 350 2538, Fax. +65 251 6500

**Slovakia:** see Austria

**Slovenia:** see Italy

**South Africa:** S.A. PHILIPS Pty Ltd., 195-215 Main Road Martindale,  
2092 JOHANNESBURG, P.O. Box 7430 Johannesburg 2000,  
Tel. +27 11 470 5911, Fax. +27 11 470 5494

**South America:** Al. Vicente Pinzon, 173, 6th floor,  
04547-130 SÃO PAULO, SP, Brazil,  
Tel. +55 11 821 2333, Fax. +55 11 821 2382

**Spain:** Balmes 22, 08007 BARCELONA,  
Tel. +34 93 301 6312, Fax. +34 93 301 4107

**Sweden:** Kottbygatan 7, Akalla, S-16485 STOCKHOLM,  
Tel. +46 8 5985 2000, Fax. +46 8 5985 2745

**Switzerland:** Allmendstrasse 140, CH-8027 ZÜRICH,  
Tel. +41 1 488 2741 Fax. +41 1 488 3263

**Taiwan:** Philips Semiconductors, 6F, No. 96, Chien Kuo N. Rd., Sec. 1,  
TAIPEI, Taiwan Tel. +886 2 2134 2865, Fax. +886 2 2134 2874

**Thailand:** PHILIPS ELECTRONICS (THAILAND) Ltd.,  
209/2 Sanpavuth-Bangna Road Prakanong, BANGKOK 10260,  
Tel. +66 2 745 4090, Fax. +66 2 398 0793

**Turkey:** Talatpasa Cad. No. 5, 80640 GÜLTEPE/ISTANBUL,  
Tel. +90 212 279 2770, Fax. +90 212 282 6707

**Ukraine:** PHILIPS UKRAINE, 4 Patrice Lumumba str., Building B, Floor 7,  
252042 KIEV, Tel. +380 44 264 2776, Fax. +380 44 268 0461

**United Kingdom:** Philips Semiconductors Ltd., 276 Bath Road, Hayes,  
MIDDLESEX UB3 5BX, Tel. +44 181 730 5000, Fax. +44 181 754 8421

**United States:** 811 East Arques Avenue, SUNNYVALE, CA 94088-3409,  
Tel. +1 800 234 7381, Fax. +1 800 943 0087

**Uruguay:** see South America

**Vietnam:** see Singapore

**Yugoslavia:** PHILIPS, Trg N. Pasicca 5/v, 11000 BEOGRAD,  
Tel. +381 11 62 5344, Fax. +381 11 63 5777

**For all other countries apply to:** Philips Semiconductors,  
International Marketing & Sales Communications, Building BE-p, P.O. Box 218,  
5600 MD EINDHOVEN, The Netherlands, Fax. +31 40 27 24825

**Internet:** <http://www.semiconductors.philips.com>

© Philips Electronics N.V. 1999

SCA61

All rights are reserved. Reproduction in whole or in part is prohibited without the prior written consent of the copyright owner.

The information presented in this document does not form part of any quotation or contract, is believed to be accurate and reliable and may be changed without notice. No liability will be accepted by the publisher for any consequence of its use. Publication thereof does not convey nor imply any license under patent- or other industrial or intellectual property rights.

Printed in The Netherlands

545002/00/02/pp32

Date of release: 1999 Jan 22

Document order number: 9397 750 04896

*Let's make things better.*

**Philips**  
Semiconductors



**PHILIPS**