



MASTER INSTRUMENT CORPORATION

SINGLE-PHASE BRIDGE RECTIFIER W005MF THRU W10MF

VOLTAGE RANGE 50 to 1000 Volts
CURRENT 1.5 Amperes

FEATURES

- I Low cost
- I This series is UL recognized under component index, file number E127707
- I High forward surge current capability
- I Ideal for printed circuit board
- I High temperature soldering guaranteed: 260°C/10 second, at 5 lbs. (2.3kg) tension.

MECHANICAL DATA

- I Case: Molded plastic body
- I Terminal: Lead solderable per MIL-STD-202E method 208C.
- I Polarity: Polarity symbols molded on case
- I Mounting position: Any
- I Weight: 0.042ounce, 1.2grams

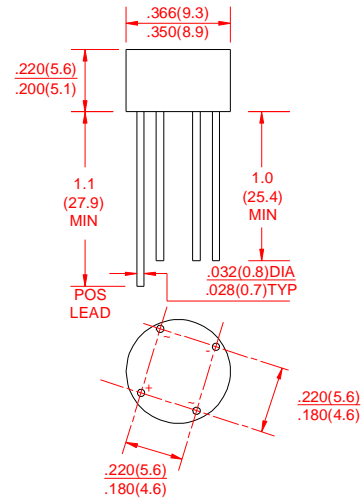

Dimensions in inches and (millimeters)

MAXIMUM RATINGS AND ELECTRICAL CHARACTERISTICS

Ratings at 25°C ambient temperature unless otherwise specified.
Single phase, half wave, 60Hz, resistive or inductive load.
For capacitive load derate current by 20%.

	SYMBOLS	W005MF	W01MF	W02MF	W04MF	W06MF	W08MF	W10MF	UNITS
Maximum Repetitive Peak Reverse Voltage	V_{RRM}	50	100	200	400	600	800	1000	Volts
Maximum RMS Voltage	V_{RMS}	35	70	140	280	420	560	700	Volts
Maximum DC Blocking Voltage	V_{DC}	50	100	200	400	600	800	1000	Volts
Maximum Average Forward Rectified Output Current, at $T_A=25^\circ\text{C}$ (Note1)	$I_{(AV)}$	1.5							Amps
Peak Forward Surge Current 8.3ms single half sine-wave superimposed on rated load (JEDEC Method)	I_{FSM}	50							Amps
Ratings for Fusing ($t < 8.3\text{ms}$)	I^2T	10							A^2S
Maximum Instantaneous Forward Voltage at 1.0A	V_F	1.3							Volts
Maximum DC Reverse Current at rated DC blocking voltage per element	$T_A=25^\circ\text{C}$	5.0				10			μAmps
	$T_A=100^\circ\text{C}$	0.5							mAmps
Typical Junction Capacitance(Note2)	C_J	25							pF
Maximum reverse recovery time (Note 3) $T_J=25^\circ\text{C}$	T_{RR}	150				250	500		nS
Operating Temperature Range	T_J	-55 to +150							$^\circ\text{C}$
Storage Temperature Range	T_{STG}	-55 to +150							$^\circ\text{C}$

NOTES:

1. Unit mounted on P.C. board with $0.22'' \times 0.22'' (5.5 \times 5.5\text{mm})$ copper pads, $0.375'' (9.5\text{mm})$ lead length.
2. Measured at 1.0MHz and applied reverse voltage of 4.0 volts.
3. Reverse recovery test conditions: $I_F=0.5\text{A}$, $I_R=1.0\text{A}$, $I_{RR}=0.25\text{A}$



MASTER INSTRUMENT CORPORATION

SINGLE-PHASE BRIDGE RECTIFIER
W005MF THRU W10MF

VOLTAGE RANGE 50 to 1000 Volts
CURRENT 1.5 Amperes

RATINGS AND CHARACTERISTIC CURVES W005MF THRU W10MF

FIG.1- DERATING CURVE FOR OUTPUT RECTIFIED CURRENT

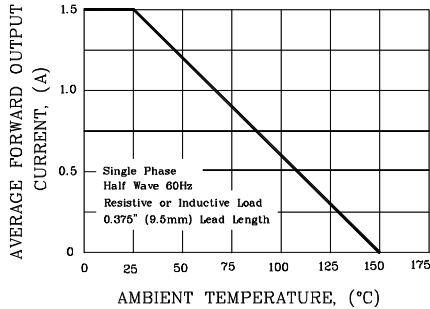

FIG.2- MAXIMUM NON-REPETITIVE PEAK FORWARD SURGE CURRENT PER ELEMENT

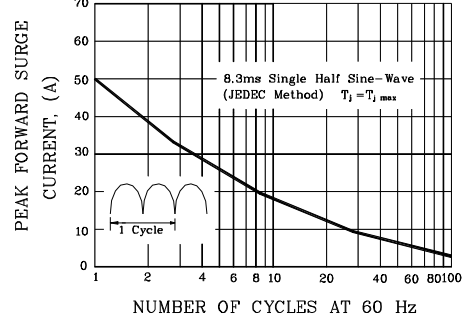

FIG.3- TYPICAL FORWARD CHARACTERISTICS PER BRIDGE ELEMENT

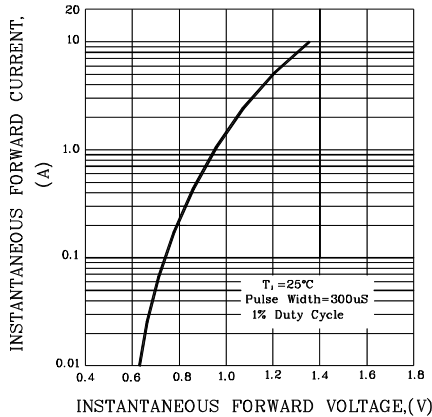

FIG.4- TYPICAL REVERSE CHARACTERISTICS PER BRIDGE ELEMENT

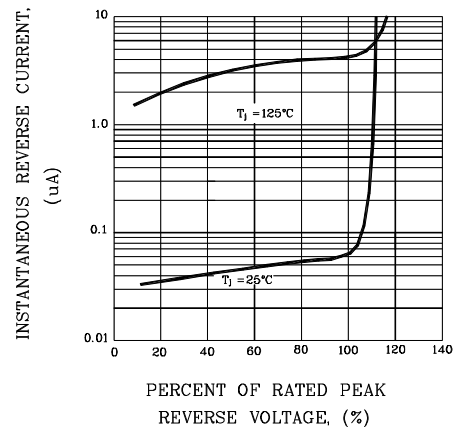

FIG.5- TYPICAL JUNCTION CAPACITANCE PER BRIDGE ELEMENT

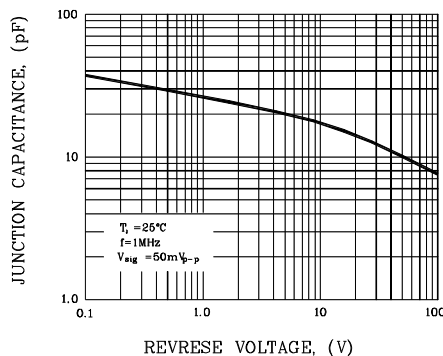

FIG.6- TEST CIRCUIT DIAGRAM AND REVERSE RECOVERY TIME CHARACTERISTIC

