

SP100 and V400 Series Speakers and Speaker/Strobes

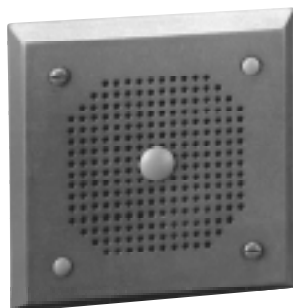

A Division of Pittway
3825 Ohio Avenue, St. Charles, IL 60174
1-800-SENSOR2 (736-7672), Fax 630-377-6495
<http://www.systemsensor.com>



SP101 Speaker



**V400 Speaker
with ADA Strobe**



SP100 Speaker

Features

- Dual voltages: 25 and 70.7 Vrms
- Multiple selectable taps
 - SP100: $\frac{1}{8}$ - 4 watts
 - V400: $\frac{1}{4}$ - 2 watts
- Peak dBA:
 - SP100: 96 @ 4 watts
 - V400: 90 @ 2 watts
- Multiple strobe options
 - ADA/UL 1971 @ 15, 15/75, 75, or 110 cd (24 VDC only)
- Listed to UL Standard 1480 for speakers for fire protective signaling systems

System Sensor SP100 Series and V400 Series Speakers are the Sound Choice™ for voice, tone, and visible signaling. The SP100 Series are high quality speakers and speaker/strobe combinations for evacuation signaling

designed to meet UL1480 Fire Standard Specifications. Sound Choice speakers are available with ADA/UL1971 listed strobes for public mode applications.

Specifications – SP100 Series

Mechanical

Input Terminals:	12 to 18 AWG
Grille Size/Color:	
Round:	8" (203 mm)/white
Square:	5" (127 mm)/red or white
Weight:	1.6 lb (725 gm)
Mounting:	4" × 4" × 2 ¹ / ₈ " backbox with 4" × 4" × 1 ¹ / ₂ " extension ring

Filler Plugs:	Included
Operating Temperature Range:	32° to 120° F (0° to 49° C)

Electrical

Voltage Input:	25 volts or 70.7 volts (nominal)
Frequency Range:	400 – 4000 Hz

Although the SP100 Series speaker/strobe combination is sold as a unit, the speaker and strobe are electrically independent and require separate power sources. See chart on page 2 for strobe operating requirements.



SP100 Series Speaker/Strobe Power Requirements

	<u>SP1W2415ADA</u> <u>SP1R2415ADA</u>	<u>SP1W241575ADA</u> <u>SP1R241575ADA</u>	<u>SP1W2475ADA</u> <u>SP1R2475ADA</u>	<u>SP1W24110ADA</u> <u>SP1R24110ADA</u>
Supply Voltage:	20-30 VDC	20-30 VDC	20-30 VDC	20-30 VDC
Max. Current @ Listed Voltage:	75 mA	93 mA	170 mA	210 mA
Operating Current				
@ Rectified Unfiltered Voltage:	90 mA	120 mA	200 mA	245 mA
Rated Light Output	15.0 cd	15/75 cd	75.0 cd	110.0 cd

Specifications – V400 Series

Mechanical

Input Terminals:	14 to 18 AWG
Grille Size/Color:	4" (102 mm)/red or beige
Weight:	.7 lb (317 gm)
Mounting:	
Semiflush*:	4" × 4" × 1 ¹ / ₂ "-2 ¹ / ₈ " standard backbox**
Flush*:	deep backbox (BBD) with flush mounting plate

Operating

Temperature Range: 32° to 120° F (0° to 49° C)

Electrical

Voltage Input: 25 volts or 70.7 volts (nominal)
Frequency Range: 400 – 4000 Hz

*Order mounting plates separately.

**For 12- or 14-gauge wire, a 2¹/₈" backbox is recommended.

Engineering Specifications

Speaker shall be a System Sensor Model _____ dual transformer speaker capable of operating at 25 and 70.7 Vrms. Speaker shall be listed to Underwriter's Laboratories Standard 1480 for fire protective signaling systems. Speaker shall have a frequency range of 400 to 4000 Hz and shall have an operating temperature between 32° and 120° F. Speaker shall have power taps which are selected by means of a jumper wire(s).

For speaker/strobe combination:

Speaker/strobe shall be a System Sensor Speaker/Strobe Model _____ dual transformer speaker capable of

operating at 25 and 70.7 Vrms. Speaker/strobe shall be listed to Underwriter's Laboratories Standard 1480 for fire protective signaling systems. Speaker shall have a frequency range of 400 to 4000 Hz and shall have an operating temperature between 32° and 120° F. Speaker shall have power taps which are selected by means of a jumper wire(s). Strobe shall be powered independently of the speaker and shall operate from a 24 VDC or 24 Vrms full wave rectified unfiltered power supply. Strobe shall have a light output rating of 15, 75, or 110 candela and shall be UL 1971 listed as a primary signaling device.

Power Tap Selection and Sound Output

	SP100*						V400			
	4 W	2 W	1 W	1/2 W	1/4 W	1/8 W	2	1	1/2	1/4
Jumper Wire, 25 V:	1 B	1 A	2 B	2 A	3 B	4 B	-	-	-	-
Jumper Wire, 70.7 V:	2 A	3 B	4 B	5 B	6 B	6 A	-	-	-	-
UL Reverberant (dBA @ 10 ft):	90	87	84	81	78	75	84	81	78	75
Anechoic (dBA @ 10 ft):	93	90	87	84	81	78	87	84	81	78
Peak Anechoic (dBA @ 10 ft):	96	93	90	87	84	81	90	87	84	81

* Example: To select 1/4 watt output @ 25 V connect blue lead to post #3, yellow to post B.

Power Tap Selection

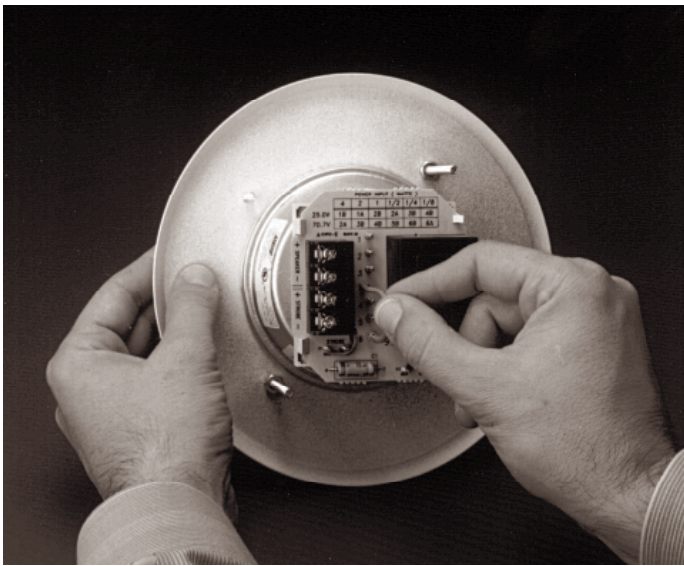

SP100

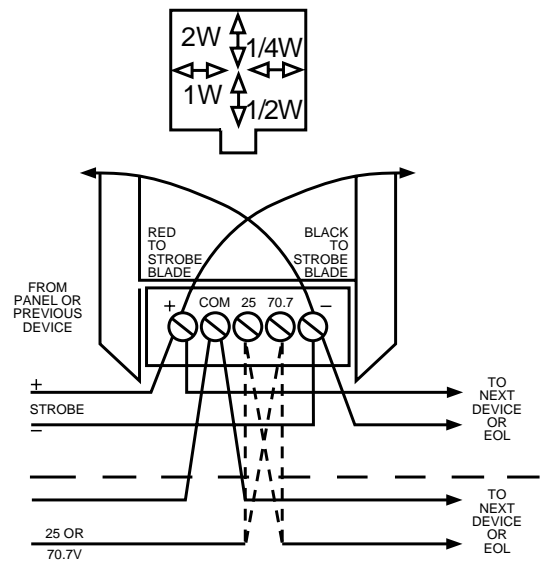

V400

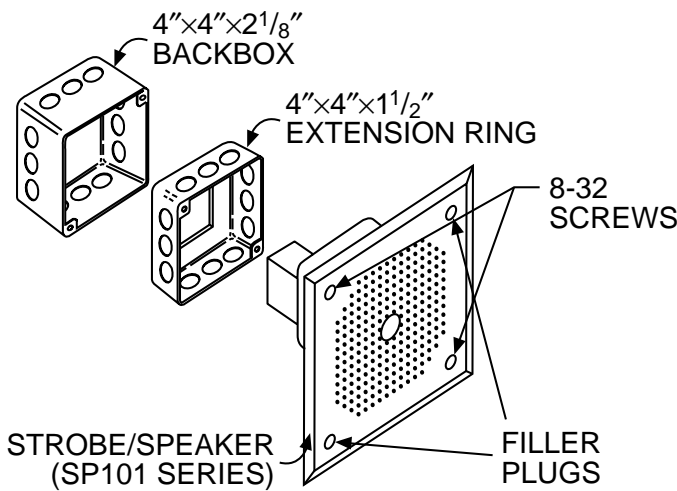

SP101 Mounting Diagram

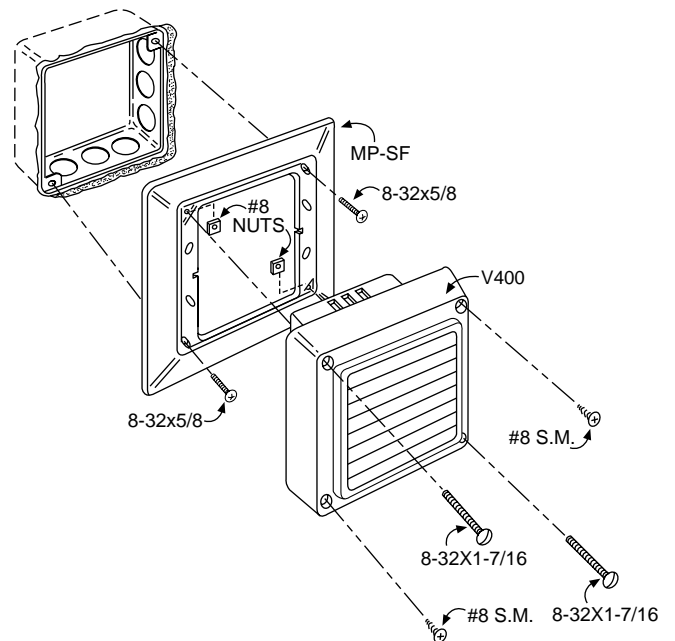

V400 Semiflush Mounting Diagram

Ordering Information – Sound Choice™ Speakers

		Description	Speaker Voltage	Strobe Voltage	Candela
<u>SP100 Series Speakers</u>					
Red	White				
-	SP100W	Round, 8" grille, 1/8-4 watt power taps	25/70.7 Vrms	-	-
SP101R	SP101W	Square, 5" grille, 1/8-4 watt power taps	25/70.7 Vrms	-	-
SP1R2415ADA	SP1W2415ADA	Square, 5" grille, 1/8-4 watt power taps, wall strobe, UL 1971	25/70.7 Vrms	24 VDC	15 cd
SP1R241575ADA	SP1W241575ADA	Square, 5" grille, 1/8-4 watt power taps, wall strobe, UL 1971	25/70.7 Vrms	24 VDC	15/75 cd
SP1R2475ADA	SP1W2475ADA	Square, 5" grille, 1/8-4 watt power taps, wall strobe, UL 1971	25/70.7 Vrms	24 VDC	75 cd
SP1R24110ADA	SP1W24110ADA	Square, 5" grille, 1/8-4 watt power taps, wall strobe, UL 1971	25/70.7 Vrms	24 VDC	110 cd

V400 Series Speakers

Red	Beige	White			
V400R	V400B	V400W	Square, 4" grille, 1/4-2 watt power taps	25/70.7 Vrms	-
V4R2415ADA	-	-	Square, 4" grille, 1/4-2 watt power taps, wall strobe, UL 1971	25/70.7 Vrms	24 VDC
V4R241575ADA	-	-	Square, 4" grille, 1/4-2 watt power taps, wall strobe, UL 1971	25/70.7 Vrms	24 VDC
V4R2475ADA	-	-	Square, 4" grille, 1/4-2 watt power taps, wall strobe, UL 1971	25/70.7 Vrms	24 VDC
V4R24110ADA	-	-	Square, 4" grille, 1/4-2 watt power taps, wall strobe, UL 1971	25/70.7 Vrms	24 VDC
MP-F	MP-FB	MP-FW	Flush mounting plate		
BB-D	-	-	Flush mounting deep backbox, 2 3/4" deep		
MP-SF	MP-SFB	MP-SFW	Semi-flush mounting plate		

UL 1638 Strobe attachments for V400*

Red	Beige				
SS12LO	-	Signal strobe	-	12 VDC	1.5 cd
SS24LO	SS24LOB	Signal strobe	-	24 VDC	1.5 cd
SS24LOC	-	Ceiling mount signal strobe	-	24 VDC	1.5 cd
SS24M	-	Signal strobe	-	24 VDC	15 cd
SS24MC	-	Ceiling mount signal strobe	-	24 VDC	15 cd

* Although the SSLO and SSM Series signal strobes are UL listed as primary signaling devices, when combined with the V400 speaker they are considered as a secondary signaling device only.

How to Order SP100 Series Speakers with Strobes

SP1R2415ADA

15 = 15 cd, UL 1971 Strobe
 1575 = 15 cd, UL 1971, 75 cd on axis
 75 = 75 cd, UL 1971 Strobe
 110 = 110 cd, UL 1971 Strobe
 24 = 24 VDC Strobe
 SP1R = Square Grille, Red Speaker
 SP1W = Square Grille, White Speaker
 V4R = V400 Square, Red Speaker

System Sensor Worldwide Manufacturing & Distribution

In Canada:

Telephone: 905-812-0767
 Fax: 905-812-0771

In the Far East:

Telephone: 852-2191-9003
 Fax: 852-2736-6580

In Italy:

Telephone: 39-40-9490-111
 Fax: 39-40-382137

In China:

Telephone: 852-2191-9003
 Fax: 852-2736-6580

In India:

Telefax: 91-022-8202564

In the United Kingdom:

Telephone: 44-1403-276500
 Fax: 44-1403-276501