

March 2003

MIL-STD-1553 / 1760 5V Monolithic Dual Transceiver

DESCRIPTION

The HI-1569 is a low power CMOS dual transceiver designed to meet the requirements of MIL-STD-1553 /1760 specifications.

The transmitter section of each channel takes complementary CMOS /TTL digital input data and converts it to bi-phase Manchester encoded 1553 signals suitable for driving the bus isolation transformer. Separate transmitter inhibit control signals are provided for each transmitter.

The receiver section of each channel converts the 1553 bus bi-phase data to complementary CMOS / TTL data suitable for inputting to a Manchester decoder. Each receiver has a separate enable input which can be used to force the output of the receiver to a logic 0.

The transmitter outputs and receiver inputs for each channel are brought out to separate sets of pins. For typical MIL-STD-1553 applications the transmitter output and receiver input will be tied together at the isolation transformer.

FEATURES

- Compliant to MIL-STD-1553A & B, MIL-STD-1760, ARINC 708A
- CMOS technology for low standby power
- Single 5V power supply
- Less than 1.0W maximum power dissipation
- Military processing options
- Industry standard 64-pin PQFP package

PIN CONFIGURATION (Top View)

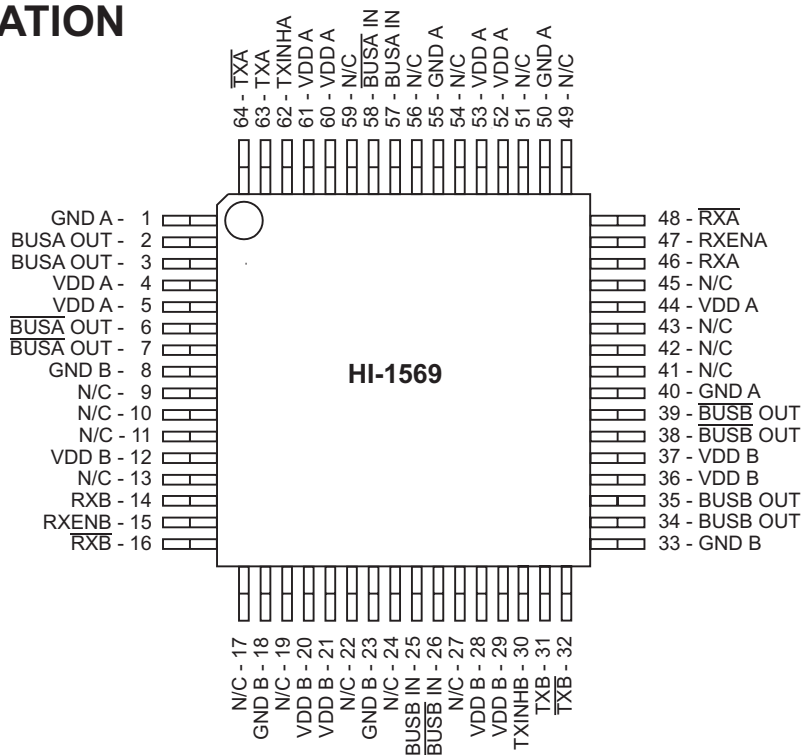

64 - Pin Plastic Quad Flat Pack (PQFP)

PIN DESCRIPTIONS

PIN	SYMBOL	FUNCTION	DESCRIPTION
1, 40, 50, 55	GNDA	power supply	Ground for channel A (Connect ALL pins)
2, 3	BUSA OUT	analog output	MIL-STD-1533 bus driver A, positive signal
4, 5, 44, 52, 53, 60, 61	VDDA	power supply	+5 volt power for channel A (Connect ALL pins)
6, 7	$\overline{\text{BUSA}} \text{ OUT}$	analog output	MIL-STD-1533 bus driver A, negative signal
8, 18, 23, 33	GNDB	power supply	Ground for channel B (Connect ALL pins)
12, 20, 21, 28, 29, 36, 37	Vddb	power supply	+5 volt power for channel B (Connect ALL pins)
14	RXB	digital output	Receiver B output, non-inverted
15	RXENB	digital input	Receiver B enable. If low, forces RXB and $\overline{\text{RXB}}$ low
16	$\overline{\text{RXB}}$	digital output	Receiver B output, inverted
25	BUSB IN	analog input	MIL-STD-1553 bus receiver B, positive signal
26	$\overline{\text{BUSB}} \text{ IN}$	analog input	MIL-STD-1553 bus receiver B, negative signal
30	TXINHB	digital input	Transmit inhibit, channel B. If high BUSB OUT, $\overline{\text{BUSB}} \text{ OUT}$ disabled
31	TXB	digital input	Transmitter B digital data input, non-inverted
32	$\overline{\text{TXB}}$	digital input	Transmitter B digital data input, inverted
34, 35	BUSB OUT	analog output	MIL-STD-1533 bus driver B, positive signal
38, 39	$\overline{\text{BUSB}} \text{ OUT}$	analog output	MIL-STD-1533 bus driver B, negative signal
46	RXA	digital output	Receiver A output, non-inverted
47	RXENA	digital input	Receiver B enable. If low, forces RXB and $\overline{\text{RXB}}$ low
48	$\overline{\text{RXA}}$	digital output	Receiver B output, inverted
57	BUSA IN	analog input	MIL-STD-1553 bus receiver A, positive signal
58	$\overline{\text{BUSA}} \text{ IN}$	analog input	MIL-STD-1553 bus receiver A, negative signal
62	TXINHA	digital input	Transmit inhibit, channel A. If high BUSA OUT, $\overline{\text{BUSA}} \text{ OUT}$ disabled
63	TXA	digital input	Transmitter A digital data input, non-inverted
64	$\overline{\text{TXA}}$	digital input	Transmitter A digital data input, inverted
9 -11, 13, 17,19, 22, 24, 27 41 - 43, 45, 49, 51, 54, 56, 59	N/C	-	Not connected. May be left open or connected to power or ground

FUNCTIONAL DESCRIPTION

The HI-1569 data bus transceiver contains differential voltage source drivers and differential receivers. It is intended for applications using a MIL-STD-1553 A/B data bus. The device produces a trapezoidal output waveform during transmission.

TRANSMITTER

Data input to the device's transmitter section is from the complementary CMOS /TTL inputs TXA/B and $\overline{\text{TXA/B}}$. The transmitter accepts Manchester II bi-phase data and converts it to differential voltages on BUSA/B OUT and $\overline{\text{BUSA/B}} \text{ OUT}$. The transceiver outputs are either direct or transformer coupled to the MIL-STD-1553 data bus. Both coupling methods produce a nominal voltage on the bus of 7.5 volts peak to peak.

The transmitter is automatically inhibited and placed in the high impedance state when both TXA/B and $\overline{\text{TXA/B}}$ are either at a logic "1" or logic "0" simultaneously. A logic "1" applied to the TXINHA/B input will force the transmitter to the high impedance state, regardless of the state of TXA/B and $\overline{\text{TXA/B}}$.

RECEIVER

The receiver accepts bi-phase differential data from the MIL-STD-1553 bus through a direct or transformer coupled interface. The receiver's differential input stage drives a filter and threshold comparator that produces CMOS/TTL data at the RXA/B and $\overline{\text{RXA/B}}$ output pins.

Each set of receiver outputs can be independently forced to a logic "0" by setting RXENA or RXENB low.

MIL-STD-1553 BUS INTERFACE

A direct coupled interface (see Figure 2) uses a 1:2.5 ratio isolation transformer and two 55 ohm isolation resistors between the transformer and the bus.

In a transformer coupled interface (see Figure 3), the transceiver is connected to a 1:1.79 isolation transformer which in turn is connected to a 1:1.4 coupling transformer. The transformer coupled method also requires two coupling resistors equal to 75% of the bus characteristic impedance (Z_0) between the coupling transformer and the bus.

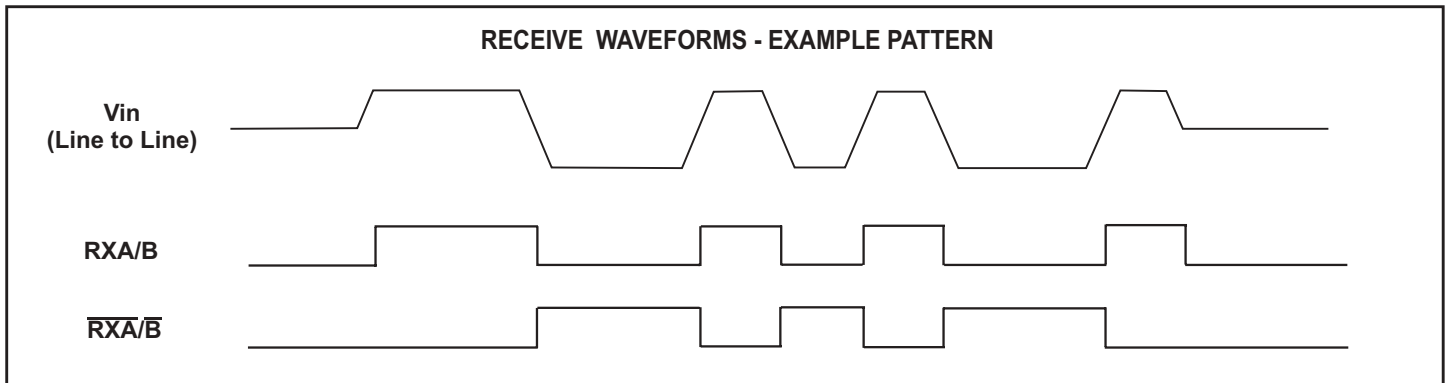
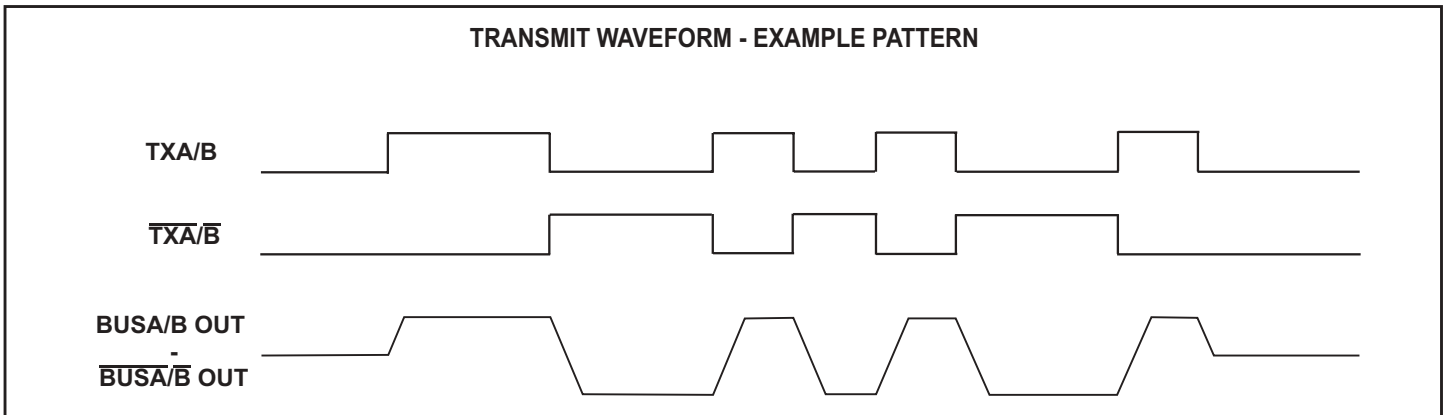
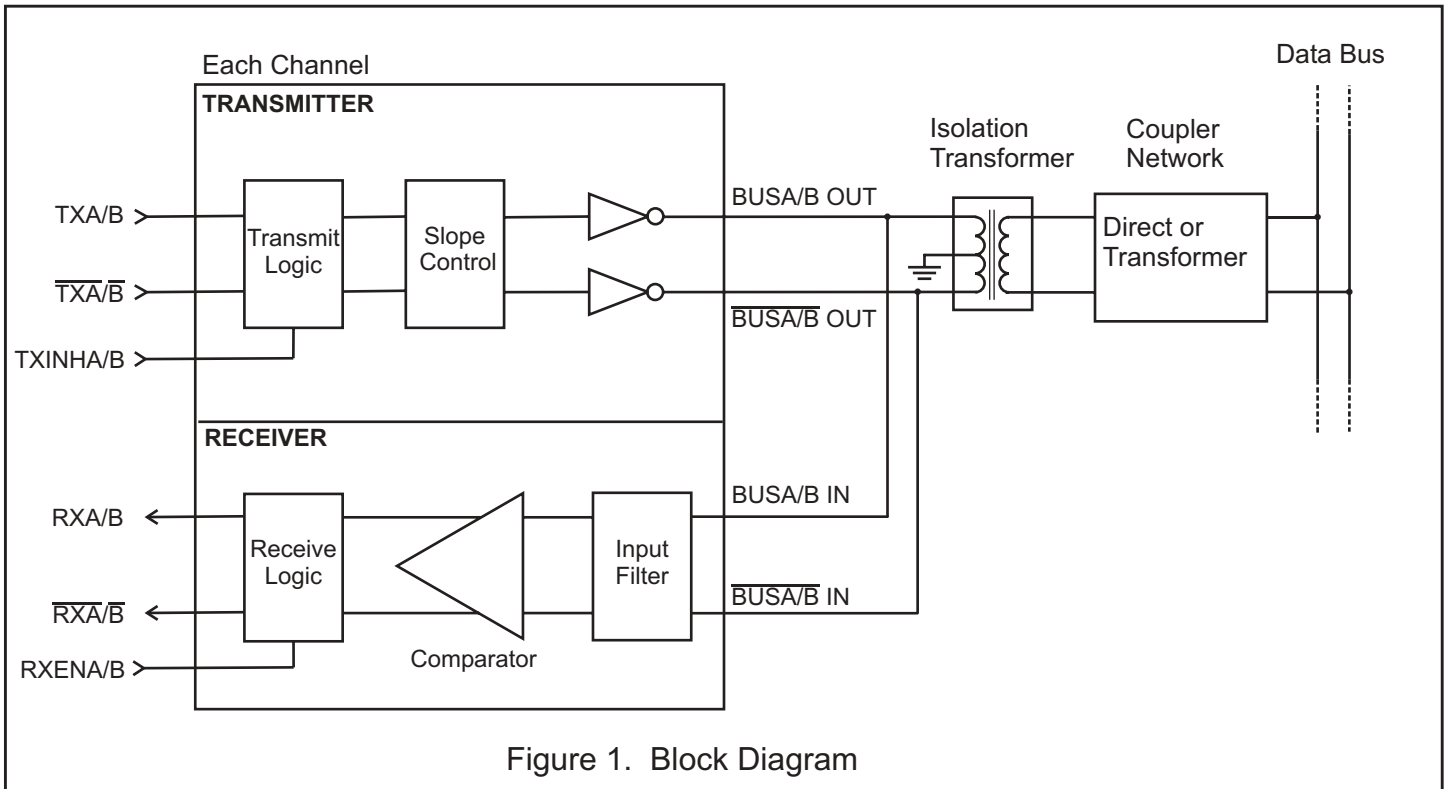

ABSOLUTE MAXIMUM RATINGS

Supply voltage (VDD)	-0.3 V to +7 V
Logic input voltage range	-0.3 V dc to +5.5 V
Receiver differential voltage	10 Vp-p
Driver peak output current	+1.0 A
Power dissipation at 25°C	1.0 W
Solder Temperature	275°C for 10 sec.
Junction Temperature	175°C
Storage Temperature	-65°C to +150°C

RECOMMENDED OPERATING CONDITIONS

Supply Voltage
VDD..... 5V... ±5%
Temperature Range
Industrial Screening.....-40°C to +85°C
Hi-Temp Screening.....-55°C to +125°C
Military Screening.....-55°C to +125°C

NOTE: Stresses above absolute maximum ratings or outside recommended operating conditions may cause permanent damage to the device. These are stress ratings only. Operation at the limits is not recommended.

DC ELECTRICAL CHARACTERISTICS

VDD = 5.0V, GND = 0V, TA = Operating Temperature Range (unless otherwise specified).

PARAMETER	SYMBOL	CONDITION	MIN	TYP	MAX	UNITS
Operating Voltage	VDD		4.75	5	5.25	V
Total Supply Current	ICC1	Not Transmitting		14	22	mA
	ICC2	Transmit one channel @ 50% duty cycle		200	340	mA
	ICC3	Transmit one channel @ 100% duty cycle		400	550	mA
Power Dissipation	PD1	Not Transmitting			0.11	W
	PD2	Transmit one channel @ 100% duty cycle		0.70	0.95	W
Min. Input Voltage (HI)	V _{IH}	Digital inputs	2.0	1.4		V
Max. Input Voltage (LO)	V _{IL}	Digital inputs		1.4	0.8	V
Min. Input Current (HI)	I _{IH}	V _{IH} = 4.9V, Digital inputs			20	µA
Max. Input Current (LO)	I _{IL}	V _{IL} = 0.1V, Digital inputs	-20			µA
Min. Output Voltage (HI)	V _{OH}	I _{OUT} = -4mA, Digital outputs	4.0			V
Max. Output Voltage (LO)	V _{IH}	I _{OUT} = 4.0mA, Digital outputs			0.4	V
RECEIVER (Measured at Point "Ad" in Figure 2 unless otherwise specified)						
Input resistance	R _{IN}	Differential	20			Kohm
Input capacitance	C _{IN}	Differential			5	pF
Common mode rejection ratio	CMRR		40			dB
Input Level	V _{IN}	Differential			9	Vp-p
Input common mode voltage	V _{ICM}		-5.0		5.0	V-pk
Threshold Voltage - Direct-coupled	Detect	V _{THD}	1 Mhz Sine Wave (Measured at Point "Ad" in Figure 2)	1.15	20.0	Vp-p
	No Detect	V _{THND}			0.28	Vp-p
Theshold Voltage - Transformer-coupled	Detect	V _{THD}	1 MHz Sine Wave (Measured at Point "At" in Figure 3)	0.86	14.0	Vp-p
	No Detect	V _{THND}			0.20	Vp-p

DC ELECTRICAL CHARACTERISTICS (cont.)

VDD = 5.0V, GND = 0V, TA = Operating Temperature Range (unless otherwise specified).

PARAMETER	SYMBOL	CONDITION	MIN	TYP	MAX	UNITS	
TRANSMITTER (Measured at Point "Ad" in Figure 2 unless otherwise specified)							
Output Voltage	Direct coupled	V _{OUT}	35 ohm load (Measured at Point "Ad" in Figure 2)	6.0		9.0	Vp-p
	Transformer coupled	V _{OUT}	70 ohm load (Measured at Point "At" in Figure 3)	20.0		27.0	Vp-p
Output Noise		V _{ON}	Differential, inhibited			10.0	mVp-p
Output Dynamic Offset Voltage	Direct coupled	V _{DYN}	35 ohm load (Measured at Point "Ad" in Figure 2)	-90		90	mV
	Transformer coupled	V _{DYN}	70 ohm load (Measured at Point "At" in Figure 3)	-250		250	mV
Output resistance		R _{OUT}	Differential, not transmitting	10			Kohm
Output Capacitance		C _{OUT}	1 MHz sine wave			15	pF

AC ELECTRICAL CHARACTERISTICS

VDD = 5.0V, GND = 0V, TA = Operating Temperature Range (unless otherwise specified).

PARAMETER	SYMBOL	TEST CONDITIONS	MIN	TYP	MAX	UNITS
RECEIVER (Measured at Point "Ad" in Figure 2)						
Receiver Delay	t _{DR}	From input zero crossing to RXA/B or $\overline{RXA/B}$			450	ns
Receiver Enable Delay	t _{REN}	From RXENA/B rising or falling edge to RXA/B or $\overline{RXA/B}$			40	ns
TRANSMITTER (Measured at Point "Ad" in Figure 2)						
Driver Delay	t _{DT}	TXA/B, TXA/B to BUSA/B OUT, $\overline{BUSA/B}$ OUT			150	ns
Rise time	t _r	35 ohm load	100		300	ns
Fall Time	t _f	35 ohm load	100		300	ns
Inhibit Delay	t _{DI-H}	Inhibited output			100	ns
	t _{DI-L}	Active output			150	ns

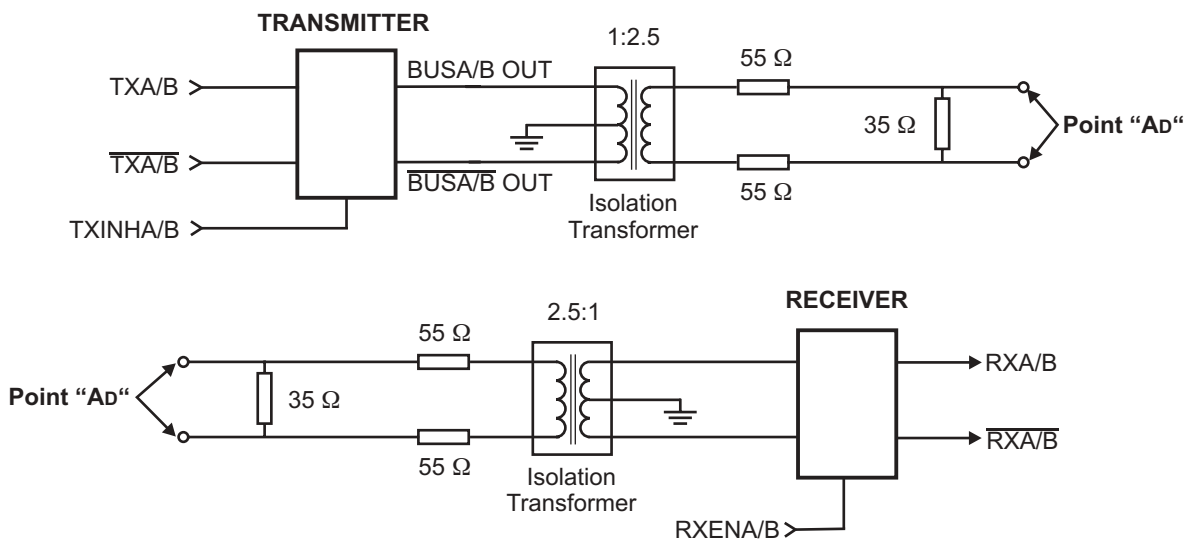

Figure 2. Direct Coupled Test Circuits

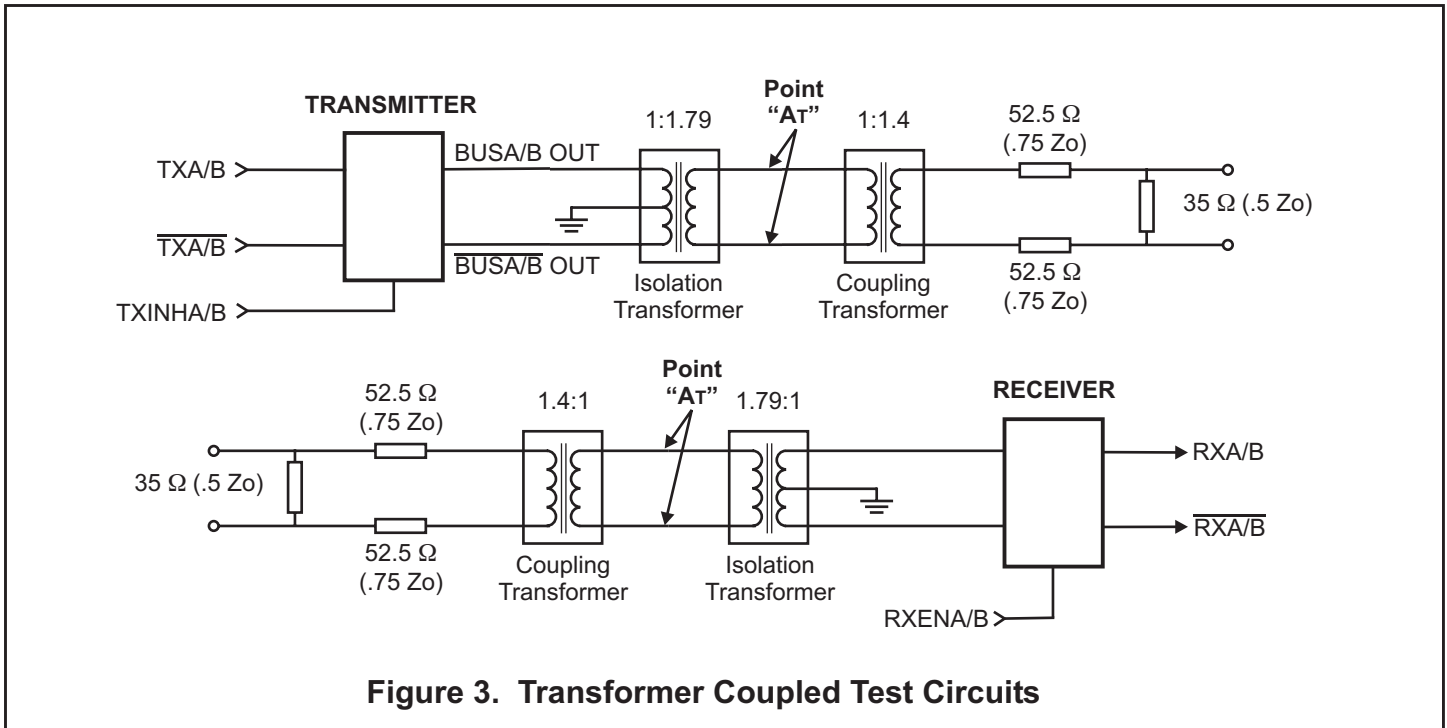

Figure 3. Transformer Coupled Test Circuits

ORDERING INFORMATION

PART NUMBER	PACKAGE DESCRIPTION	TEMPERATURE RANGE	PROCESS FLOW	BURN IN	LEAD FINISH
HI-1569PQI	64 PIN PLASTIC PQFP	-40°C TO +85°C	I	NO	SOLDER
HI-1569PQT	64 PIN PLASTIC PQFP	-55°C TO +125°C	T	NO	SOLDER
HI-1569PQM	64 PIN PLASTIC PQFP	-55°C TO +125°C	M	YES	SOLDER

CIRCUIT DESIGN CONSIDERATIONS

Holt's Application Note AN-500 contains useful information regarding circuit design and layout when using MIL-STD-1553 transceivers.

THERMAL CHARACTERISTICS

PART NUMBER	PACKAGE DESCRIPTION	CONDITION	θ _{JA}	JUNCTION TEMPERATURE		
				T _A =25°C	T _A =85°C	T _A =125°C
HI-1569PQI HI-1569PQT HI-1569PQM	64 PIN PLASTIC PQFP	Socketed	46.3°C/W	58°C	118°C	157°C

Data taken at VDD=5.0V, continuous transmission at 1Mbit/s, single transmitter enabled.

RECOMMENDED TRANSFORMERS

The HI-1569 transceiver has been characterized for compliance with the electrical requirements of MIL-STD-1553 when used with the following transformers. Holt recommends the Premier Magnetics parts as offering the best combination of electrical performance, low cost and small footprint.

MANUFACTURER	PART NUMBER	APPLICATION	TURNS RATIO(S)	DIMENSIONS
Technotrol	TL1553-45	Isolation	Dual tapped 1:1.79, 1:2.5	.630 x .630 x .155 inches
Premier Magnetics	PM-DB2725EX	Isolation	Dual tapped 1:1.79, 1:2.5	.500 x .500 x .375 inches
Technotrol	TQ1553-2	Stub coupling	1:1.4	.625 x .625 x .250 inches
Premier Magnetics	PM-DB2702	Stub coupling	1:1.4	.625 x .500 x .250 inches

64-PIN PLASTIC QUAD FLAT PACK (PQFP)

Package Type: 64PQS

