

800MHz TDMA FRONT-END GaAs MMIC

■GENERAL DESCRIPTION

NJG1707PG1 is a front-end IC for a digital cellular phone of 800MHz band. A 2x6 antenna switches and a low noise amplifier are included.

The parallel control signals of three bits logic connect T/R circuits to internal two antennas or external two antennas. The termination ports with external matching circuits make low interference between diversity antennas.

The ultra small & thin FFP32-G1 package is adopted.

■PACKAGE OUTLINE

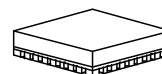

NJG1707PG1

■FEATURES

- Ultra small & thin package FFP32-G1 (Mount Size: 4.5x4.5x0.85mm)
- Antenna Switch
 - Low voltage operation -2.5V (Tx only) and +3.5V
 - Low current consumption 10uA typ. (Tx Mode, $P_{in}=30\text{dBm}$), 2uA typ. (Rx Mode, $P_{in}=10\text{dBm}$)
 - Low insertion loss 0.5dB typ. @ (Tx-ANT1, Tx-EXT1) $f_{in}=960\text{MHz}$, $P_{in}=30\text{dBm}$
 - Low Adjacent Channel Leakage Power -63dBc typ. @ $V_{DD}=+3.5\text{V}$, $V_{SS}=-2.5\text{V}$, $f_{in}=960\text{MHz}$, $P_{in}=30\text{dBm}$
- Low Noise Amplifier
 - Low voltage operation +2.7V typ.
 - Low current consumption +2.7mA typ.
 - Small signal gain 17.5dB typ. @ $f=820\text{MHz}$
 - Low noise figure 1.4dB typ. @ $f=820\text{MHz}$
 - High input IP3 IIP3=-4.5dBm typ. OIP3=+13dBm typ. @ $f=820\text{MHz}+820.1\text{MHz}$

■PIN CONFIGURATION

FFP32 Type
(Top View)

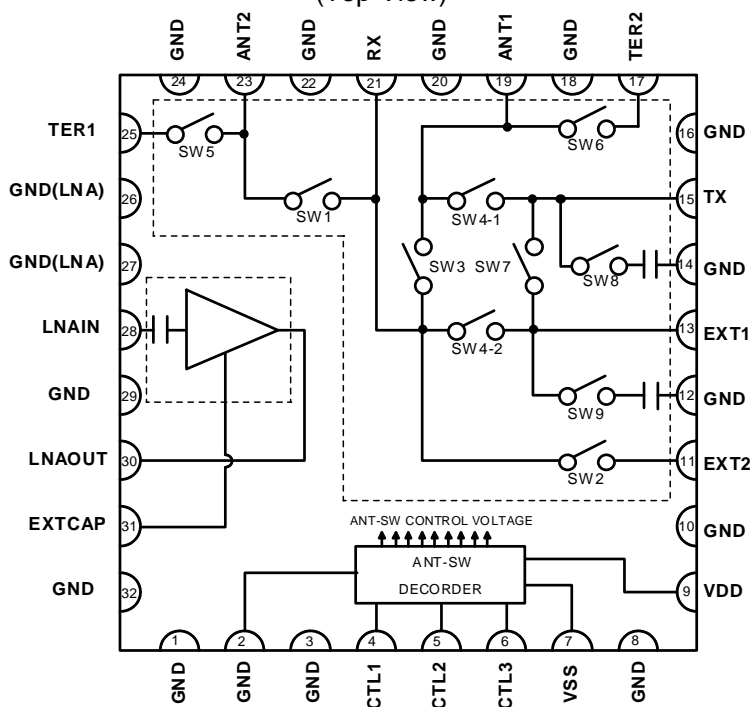

NJG1707PG1

■ABSOLUTE MAXIMUM RATINGS

(T_a=25°C)

PARAMETER	SYMBOL	CONDITONS	RATINGS	UNITS
Supply Voltage 1	V _{DD1}	V _{DD} Terminal	6.0	V
Supply Voltage 2	V _{DD2}	LNAOUT Terminal	5.0	V
Supply Voltage 3	V _{SS}	V _{SS} Terminal	-4.0~+0.3	V
Control Voltage	V _{CTL}	CTL1, CTL2, CTL3 Terminals	6.0	V
Input Power	P _{in}	TX, ANT1, EXT1 Terminals	37	dBm
		RX, ANT2, EXT2 Terminals	28	dBm
		LNAIN Terminal	10	dBm
Power Dissipation	P _D		600	mW
Operating Temperature	T _{opr}		-40~+85	°C
Storage Temperature	T _{stg}		-55~+125	°C

■ELECTRICAL CHARACTERISTICS 1 [ANTENNA SWITCH DC CHARACTERISTICS]

General Conditions: T_a=25°C, V_{DD}=3.5V, V_{SS}=-2.5V
 TX, RX, ANT1, ANT2, EXT1, EXT2: terminated (50Ω)
 TER1, TER2 : grounded by 10pF capacitor

PARAMETER	SYMBOL	CONDITIONS	MIN	TYP	MAX	UNITS
Positive Supply Voltage	V _{DD}	V _{DD} Terminal	2.7	3.5	5.0	V
Negative Supply Voltage	V _{SS}	V _{SS} Terminal	-3.5	-2.5	-2.0	V
Current Consumption 1	I _{DD1}	V _{DD} Terminal Rx Mode, No RF Signal	-	2.0	5.0	μA
Current Consumption 2	I _{SS1}	V _{SS} Terminal Rx Mode, No RF Signal	-0.1	-	0	uA
Current Consumption 3	I _{DD2}	V _{DD} Terminal, f _{in} =0.1~2GHz Tx Mode, P _{in} =30dBm	-	10	30	uA
Current Consumption 4	I _{SS2}	V _{SS} Terminal, f _{in} =0.1~2GHz Tx Mode, P _{in} =30dBm	-30	-10	-	uA
Control Voltage (H)	V _{CTL(H)}	CTL1, CTL2, CTL3 Terminals	2.0	3.0	V _{DD}	V
Control Voltage (L)	V _{CTL(L)}	CTL1, CTL2, CTL3 Terminals	0	0	0.6	V
Control Current	I _{CTL}	CTL1, CTL2, CTL3=V _{DD} or CTL1, CTL2, CTL3=0V	-1.3	-	1.3	uA
Control terminal Input Impedance	R _{in}	CTL1, CTL2, CTL3 Terminals	4	-	-	MΩ

* The voltage of this terminal should be supplied before or same time with other DC supplying terminals. (CTL1~3, V_{SS}).

■ELECTRICAL CHARACTERISTICS 2 [Tx Mode]

General Conditions: $T_a=25^{\circ}\text{C}$, $V_{DD}=3.5\text{V}$, $V_{SS}=-2.5\text{V}$, $f_{in}=885\sim 940\text{MHz}$

Tested on PCB circuit as shown below.

Insertion loss of each connectors, striplines, and capacitors are excluded.

TX, RX, ANT1, ANT2, EXT1, EXT2: terminated (50Ω)

TER1, TER2: grounded by 10pF capacitor.

PARAMETER	SYMBOL	CONDITION	MIN	TYP	MAX	UNITS
Tx-ANT1 Insertion Loss	LOSS1	$P_{in}=30\text{dBm}$	-	0.50	0.65	dB
Tx-EXT1 Insertion Loss	LOSS2	$P_{in}=30\text{dBm}$	-	0.50	0.65	dB
Tx-Rx Isolation	ISL1	$P_{in}=30\text{dBm}$ Tx-ANT1, Tx-EXT1 passing	24	27	-	dB
Tx-ANT1 Isolation	ISL2	$P_{in}=30\text{dBm}$ Tx-EXT1 passing	22	25	-	dB
Tx-ANT2 Isolation	ISL3	$P_{in}=30\text{dBm}$ Tx-ANT1, Tx-EXT1 passing	33	38	-	dB
Tx-EXT1 Isolation	ISL4	$P_{in}=30\text{dBm}$ Tx-ANT1 passing	21	24	-	dB
Tx-EXT2 Isolation	ISL5	$P_{in}=30\text{dBm}$ Tx-ANT1, Tx-EXT1 passing	32	37	-	dB
Input Power at 0.5dB Compression 1	$P_{-0.5\text{dB}}(1)$	Tx-ANT1, Tx-EXT1 passing	33	35	-	dBm
Adjacent Channel Leakage Power 1	ACP1	PDC Standard, $\pm 50\text{kHz}$ offset $P_{in}=30\text{dBm}$ Input Signal ACP=-64dBc @ 30dBm	-	-63	-60	dBc
Adjacent Channel Leakage Power 2	ACP2	PDC Standard, $\pm 100\text{kHz}$ offset $P_{in}=30\text{dBm}$ Input Signal ACP=-76dBc @ 30dBm	-	-74	-70	dBc
2nd Harmonics 1	$2f_0(1)$	$P_{in}=30\text{dBm}$ Input Signal 2nd Harmonics=-70dBc	-	-65	-63	dBc
3rd Harmonics 1	$3f_0(1)$	$P_{in}=30\text{dBm}$ Input Signal 3rd Harmonics=-100dBc	-	-64	-62	dBc
VSWR 1	VSWR1	Tx-ANT1, Tx-EXT1 passing	-	1.2	1.5	
Switching Time 1	T_D1	CTL1~3	-	120	500	nsec

NJG1707PG1

■ELECTRICAL CHARACTERISTICS 3 [Rx Mode]

General Conditions: $T_a=25^{\circ}\text{C}$, $V_{DD}=3.5\text{V}$, $V_{SS}=0\text{V}$, $f_{in}=810\sim 885\text{MHz}$

Tested on PCB circuit as shown below.

Insertion loss of each connectors, striplines, and capacitors are excluded.

TX, RX, ANT1, ANT2, EXT1, EXT2: terminated (50Ω)

TER1, TER2: grounded by 10pF capacitor.

PARAMETER	SYMBOL	CONDITION	MIN	TYP	MAX	UNITS
Rx-ANT1 Insertion Loss	LOSS3	$P_{in}=10\text{dBm}$	-	0.65	0.80	dB
Rx-ANT2 Insertion Loss	LOSS4	$P_{in}=10\text{dBm}$	-	0.60	0.75	dB
Rx-EXT1 Insertion Loss	LOSS5	$P_{in}=10\text{dBm}$	-	0.70	0.85	dB
Rx-EXT2 Insertion Loss	LOSS6	$P_{in}=10\text{dBm}$	-	0.65	0.80	dB
Rx-ANT1 Isolation	ISL6	$P_{in}=10\text{dBm}$ Rx-ANT2, Rx-EXT1, Rx-EXT2 passing	22	26	-	dB
Rx-ANT2 Isolation	ISL7	$P_{in}=10\text{dBm}$ Rx-ANT1, Rx-EXT1, Rx-EXT2 passing	24	30	-	dB
Rx-EXT1 Isolation	ISL8	$P_{in}=10\text{dBm}$ Rx-ANT1, Rx-ANT2, Rx-EXT2 passing	22	26	-	dB
Rx-EXT2 Isolation	ISL9	$P_{in}=10\text{dBm}$ Rx-ANT1, Rx-ANT2, Rx-EXT1 passing	22	26	-	dB
Input Power at 1dB Compression 1	$P_{-1\text{dB}}(1)$	Rx-ANT1, Rx-ANT2, Rx-EXT1, Rx-EXT2 passing	21	26	-	dBm
VSWR 2	VSWR2	RX-ANT1, RX-ANT2, RX-EXT1, RX-EXT2 passing	-	1.2	1.6	
Switching Time 2	T_{D2}	CTL1~3	-	120	500	nsec

■ELECTRICAL CHARACTERISTICS 4 [LNA]

General Conditions: $T_a=25^{\circ}\text{C}$, $V_{DD}=3.5\text{V}$, $V_{SS}=0\text{V}$, $f_{in}=820\text{MHz}$

Tested on PCB circuit as shown below.

PARAMETER	SYMBOL	CONDITION	MIN	TYP	MAX	UNITS
Operation Frequency	f_{RF}		810	-	885	MHz
Drain Voltage	V_{DD3}		2.5	2.7	4.5	V
Current Consumption	I_{DD3}	No RF input	-	2.7	3.6	mA
Small Signal Gain	Gain		16.0	17.5	18.5	dB
Gain Flatness	G_{flat}	$f_{RF}=810\sim 885\text{MHz}$	-	0.5	1.0	dB
Noise Figure	NF		-	1.4	1.6	dB
Pout at 1dB Gain Compression Point	$P_{-1\text{dB}}(2)$		-3.0	+1.0	-	dBm
Input 3 rd order Intercept Point	IIP3		-8.0	-4.5	-	dBm
LNAIN Port VSWR	$VSWR_i$		-	1.5	2.5	
LNAOUT Port VSWR	$VSWR_o$		-	1.5	2.5	

■TERMINAL INFORMATION

PIN NO.	SYMBOL	DESCRIPTIONS
4	CTL1	Control signal input terminal of high impedance C-MOS logic. Logic level: High; more than +2V, Low; 0~+0.6V. Please connect to GND or V _{DD} with 100kΩ if potential is open or uncertain.
5	CTL2	
6	CTL3	
7	V _{SS}	Negative supply terminal. Negative voltage of -3.5~-2.0V must be supplied on Tx mode. This terminal is isolated on Rx mode, so open or -2.5~0V condition can be used. Please connect bypass capacitor with GND to keep RF performance.
9	V _{DD}	Positive supply terminal. The voltage of this terminal should be supplied before or same time with other DC supplying terminals (CTL1~3, V _{SS}). The bias voltage should be +2.7~+5.0V. Please connect bypass capacitor with GND to keep RF performance.
11	EXT2	RF port for Rx signal. A DC cut capacitor (56pF~100pF) is required to block V _{DD} voltage.
13	EXT1	RF port for Tx/Rx signal. A DC cut capacitor (56pF~100pF) is required to block V _{DD} voltage.
15	TX	Tx power input terminal. A DC cut capacitor is required to block V _{DD} voltage, and also an external matching circuit is required to improve VSWR(See Application circuit).
17	TER2	A termination terminal for ANT1 in case ANT2 is in use. The influence of ANT1 against ANT2 is reduced. A DC cut capacitor (10pF) is required to block V _{DD} voltage.
19	ANT1	RF port for Tx/Rx signal. A DC cut capacitor (56pF~100pF) is required to block V _{DD} voltage.
21	RX	Rx output terminal. A DC cut capacitor is required to block V _{DD} voltage, and also an external matching circuit is required to improve VSWR(See Application circuit).
23	ANT2	RF port for Rx signal. A DC cut capacitor (56pF~100pF) is required to block V _{DD} voltage.
25	TER1	A termination terminal for ANT2 in case ANT1 is in use. The influence of ANT2 against ANT1 is reduced. A DC cut capacitor (10pF) is required to block V _{DD} voltage.
26,27	GND(LNA)	Ground terminal of LNA. Please place ground plane close to this pin for good RF performance.
28	LNAIN	LNA input terminal. An external matching circuit is required.
30	LNAOUT	LNA output terminal. An external matching circuit with LNA biasing element L3, L4 as in application circuit is required.
31	EXTCAP	Bypass capacitor terminal of LNA. Please place C9 as in application circuit close to this terminal.
1,2,3,8,10,12,14,16,18,20,22,24,29,32	GND	Ground terminal. Please connect to ground plane as close as possible for good RF performance.

■TRUTH TABLE

"H"=V_{CTL} (H), "L"=V_{CTL} (L), "X"=H or L

ROUTE	CONTROL INPUT			CONTROL OUTPUT								
	Tx/Rx	Diversity	IN/OUT	SW1	SW2	SW3	SW4	SW5	SW6	SW7	SW8	SW9
	CTL1	CTL2	CTL3									
Tx-ANT1	H	X	H	OFF	OFF	OFF	ON	ON	OFF	OFF	OFF	ON
Tx-EXT1	H	X	L	OFF	OFF	ON	OFF	ON	ON	ON	OFF	OFF
Rx-ANT1	L	L	H	OFF	OFF	ON	OFF	ON	OFF	ON	ON	ON
Rx-ANT2	L	H	H	ON	OFF	OFF	OFF	OFF	ON	ON	ON	ON
Rx-EXT1	L	L	L	OFF	OFF	OFF	ON	ON	ON	OFF	ON	OFF
Rx-EXT2	L	H	L	OFF	ON	OFF	OFF	ON	ON	ON	ON	ON

TYPICAL CHARACTERISTICS (ANTENNA SWITCH)

Measured on the PCB evaluation circuit, losses of circuits are eliminated.

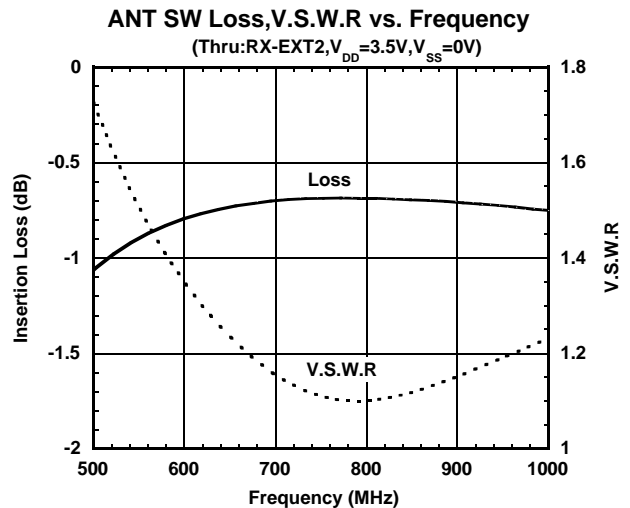
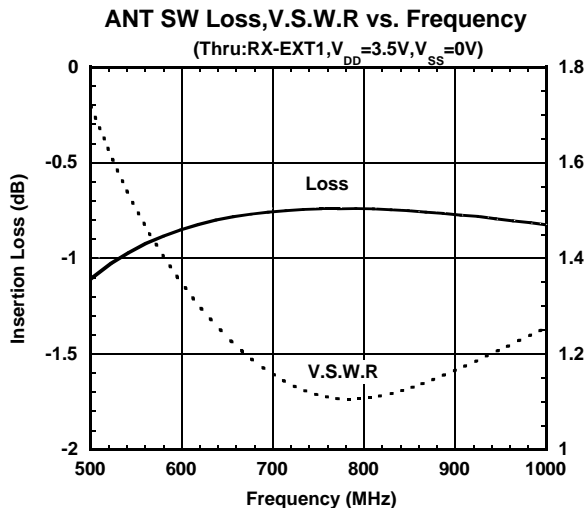
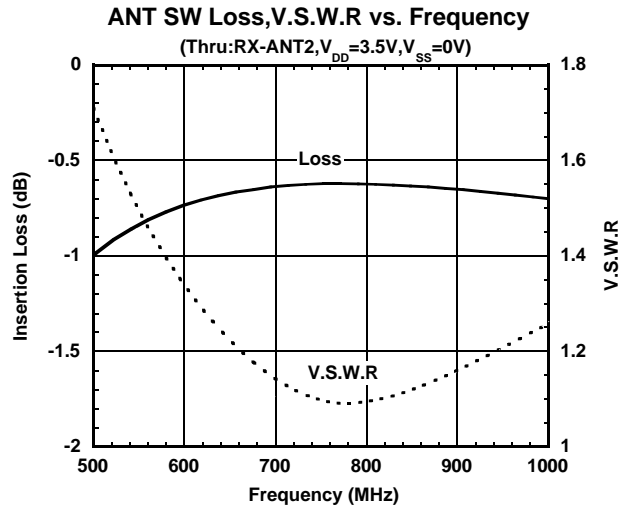
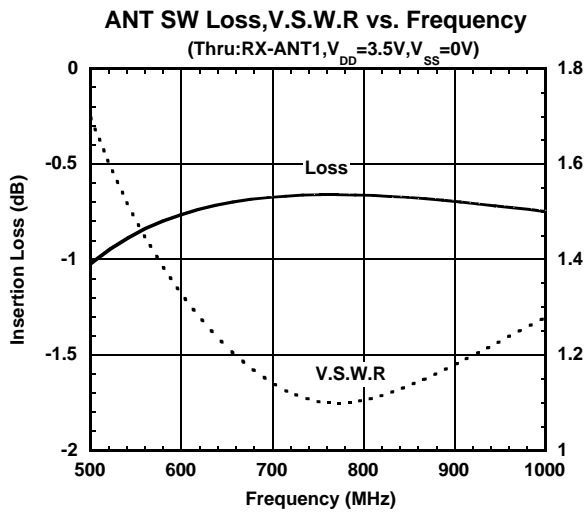
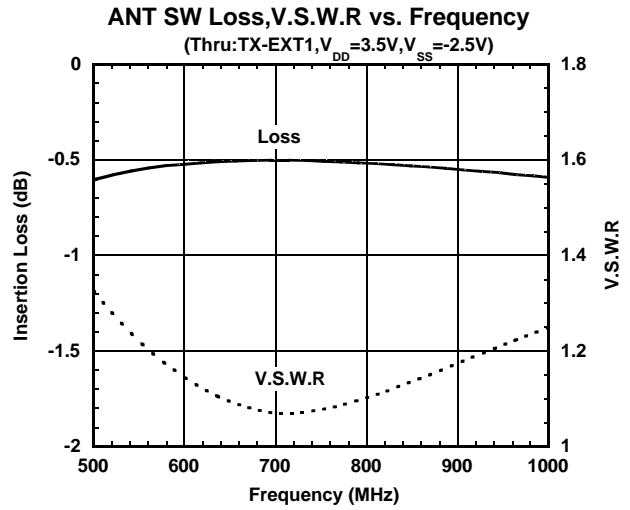
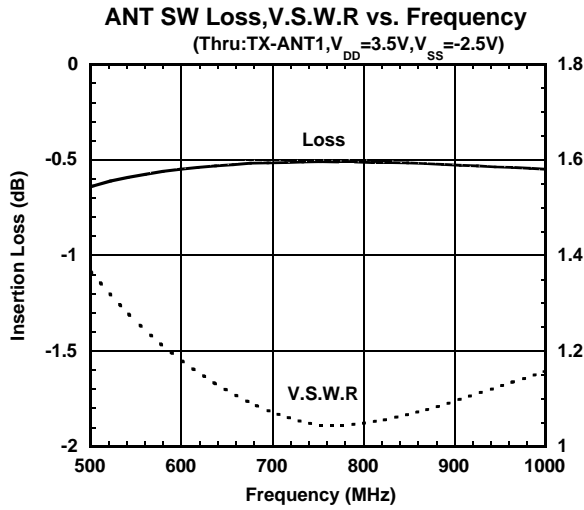

■ TYPICAL CHARACTERISTICS (ANTENNA SWITCH)

Measured on the PCB evaluation circuit, losses of circuits are eliminated.

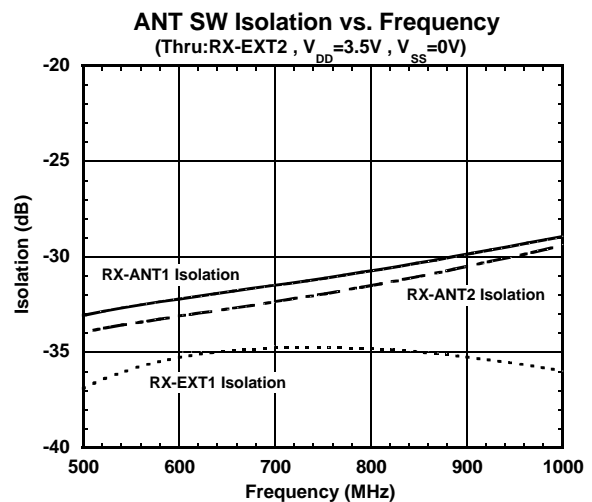
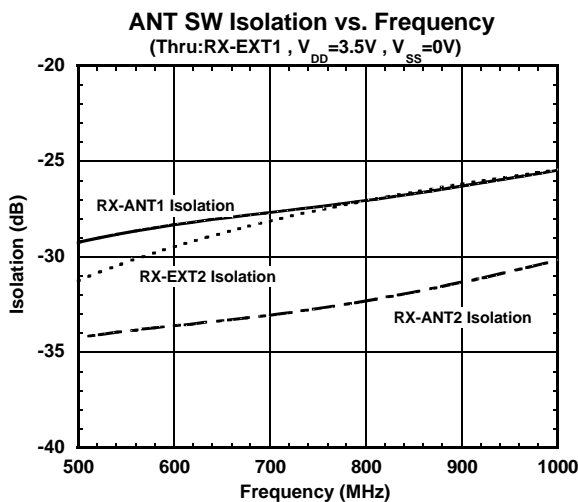
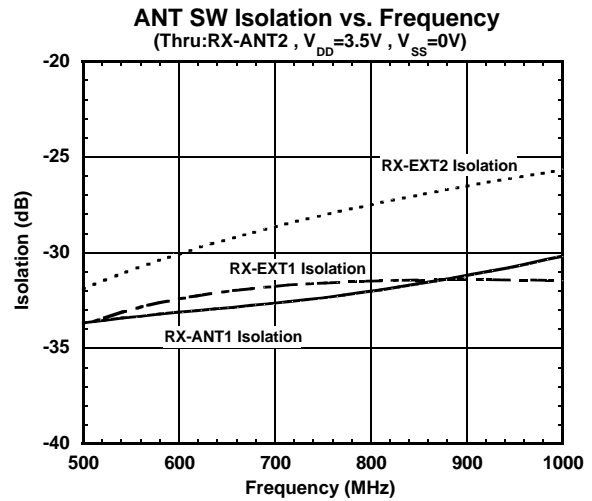
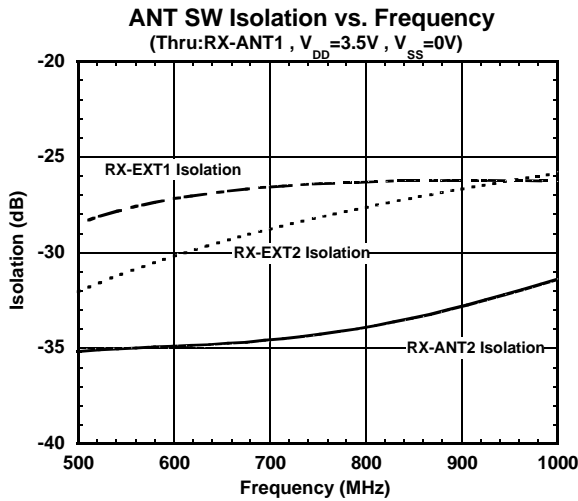
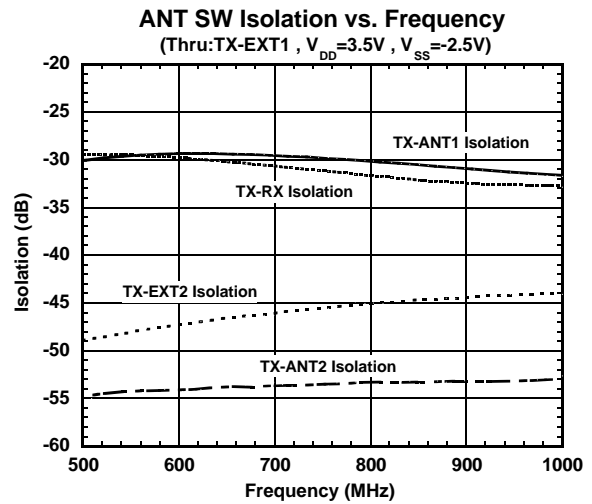
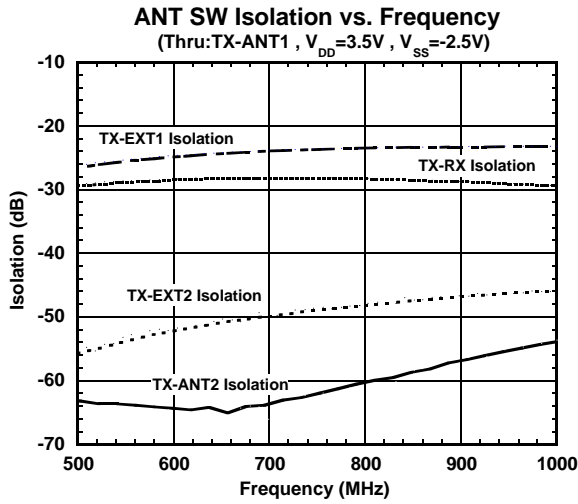

NJG1707PG1

TYPICAL CHARACTERISTICS (ANTENNA SWITCH)

Measured on the PCB evaluation circuit. losses of circuits are eliminated.

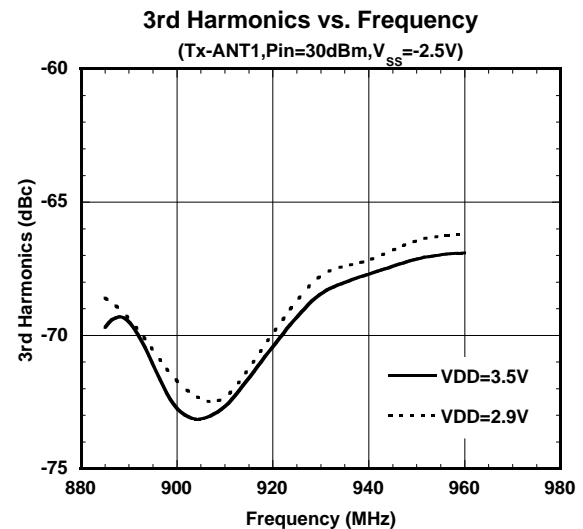
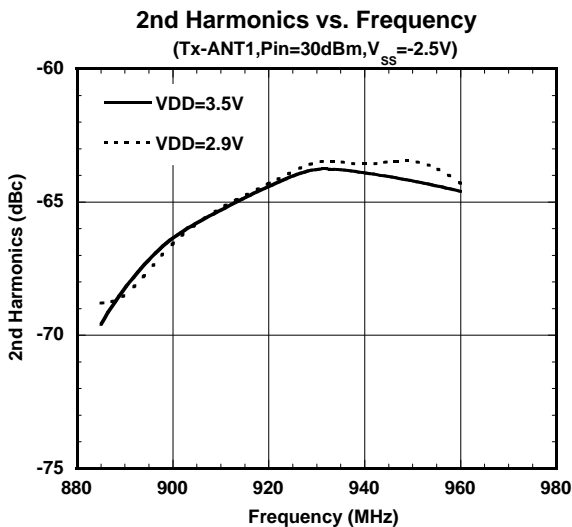
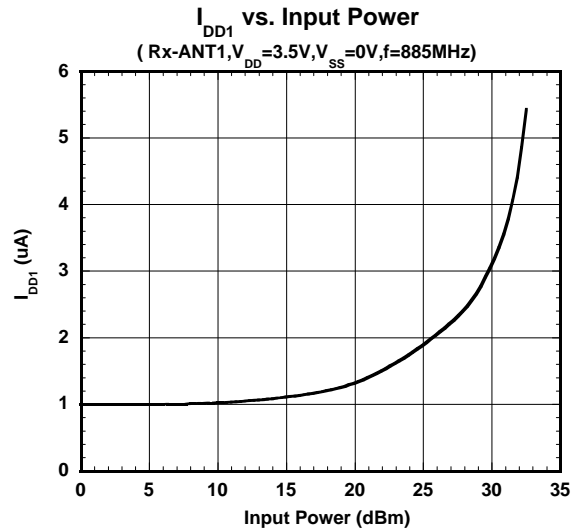
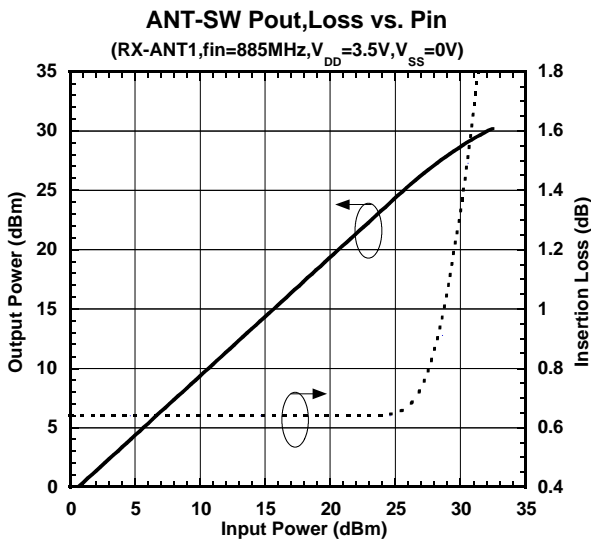
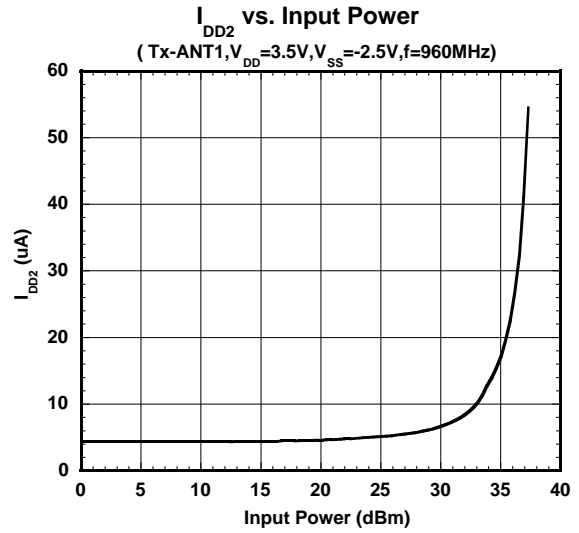
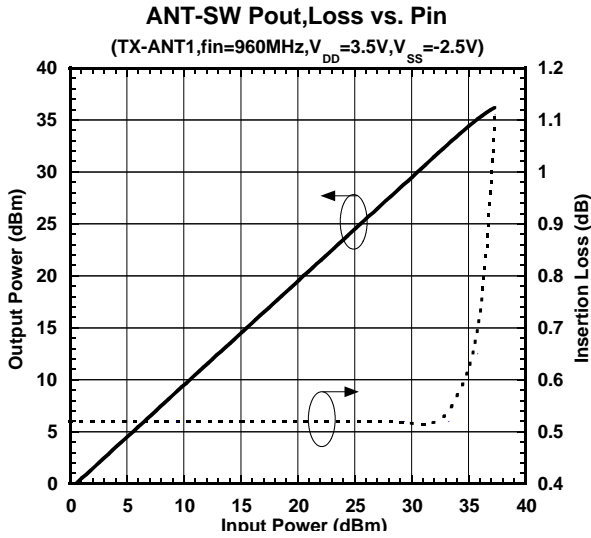

TYPICAL CHARACTERISTICS (ANTENNA SWITCH)

Measured on the PCB evaluation circuit, losses of circuits are eliminated.

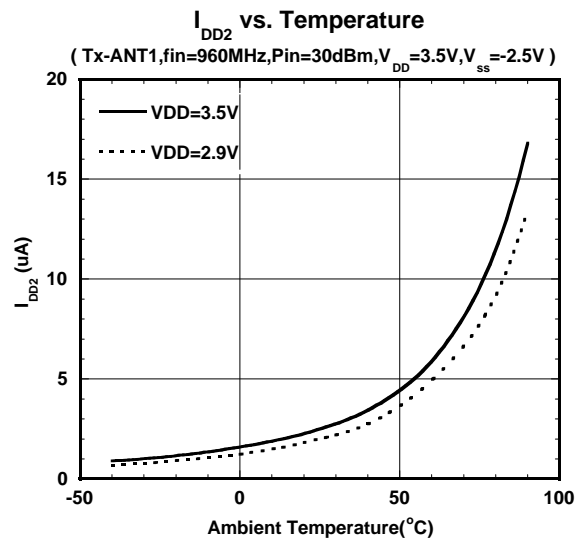
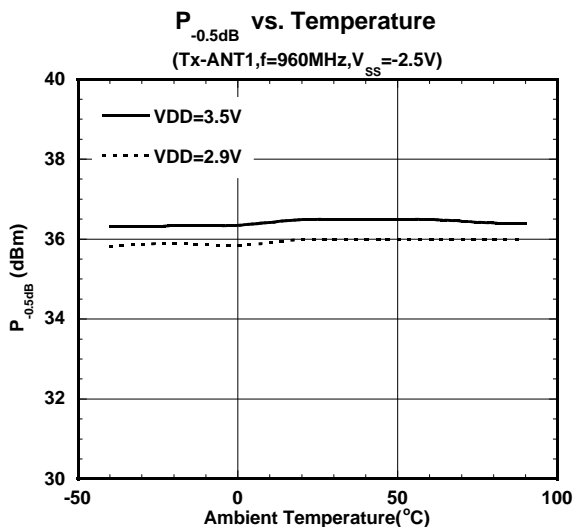
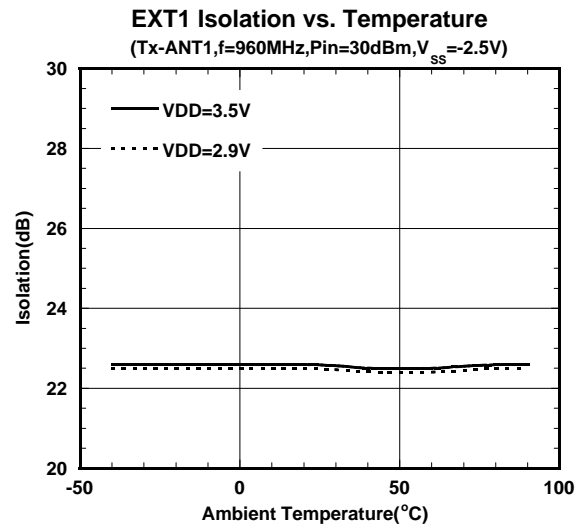
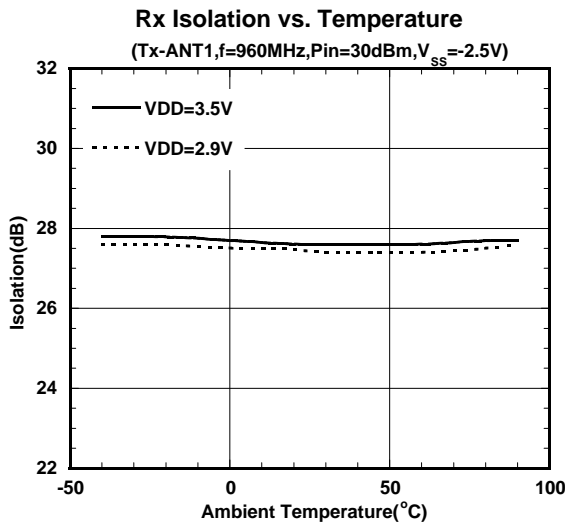
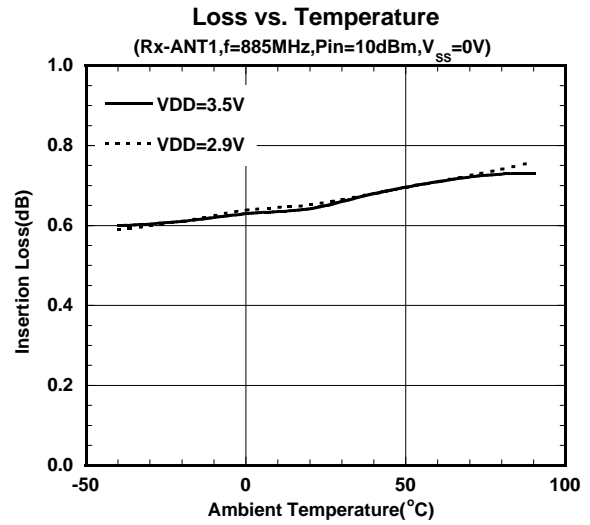
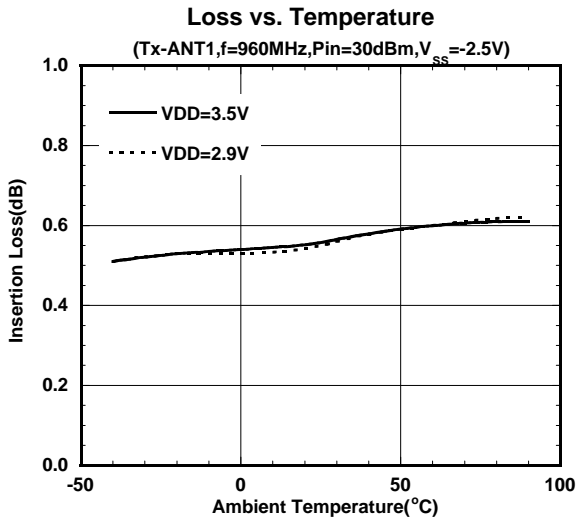

NJG1707PG1

TYPICAL CHARACTERISTICS (ANTENNA SWITCH)

Measured on the PCB evaluation circuit.

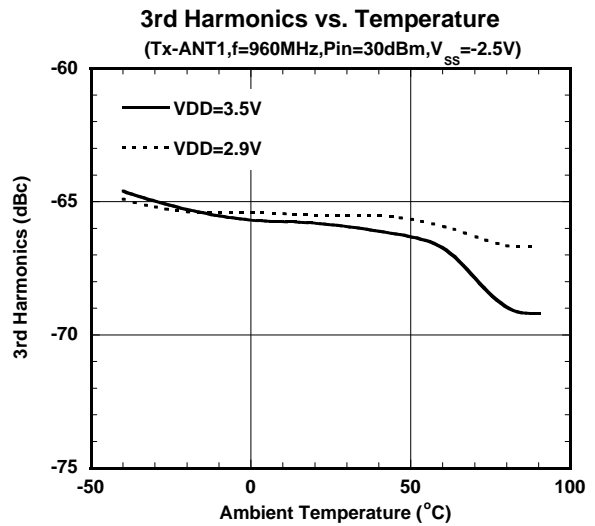
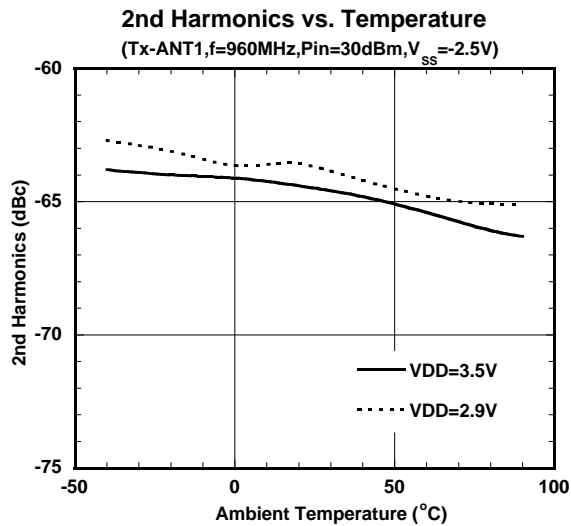
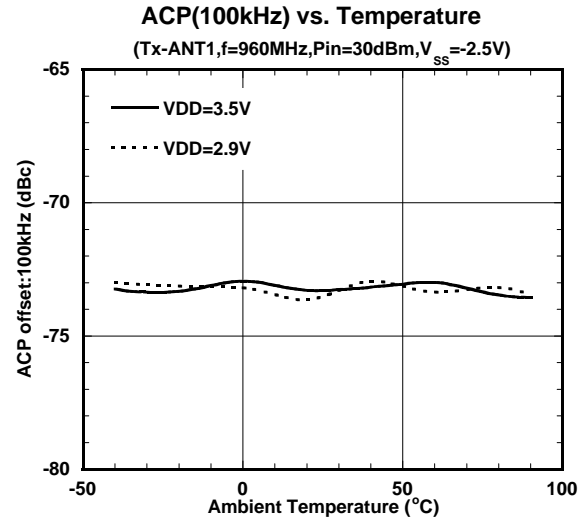
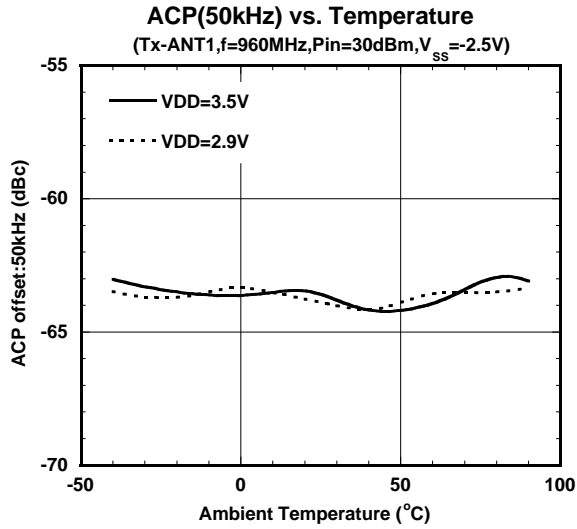

TYPICAL CHARACTERISTICS (LNA)

Measured on the PCB evaluation circuit.

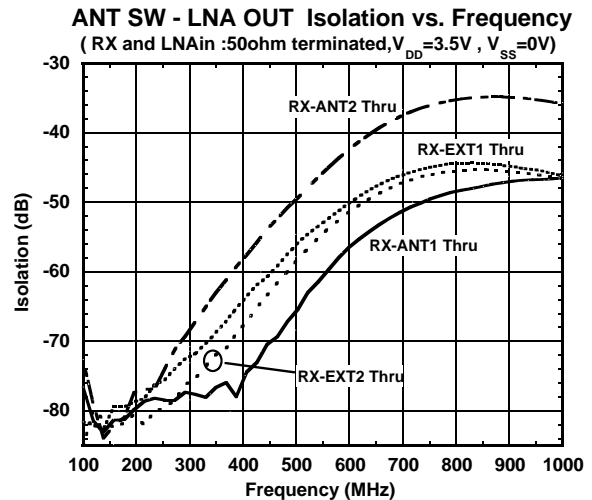
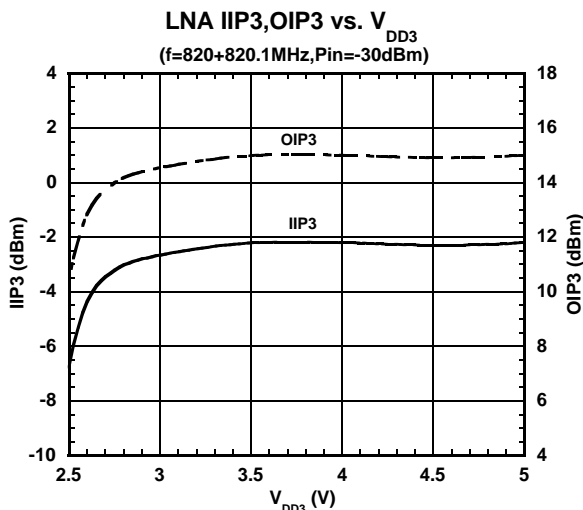
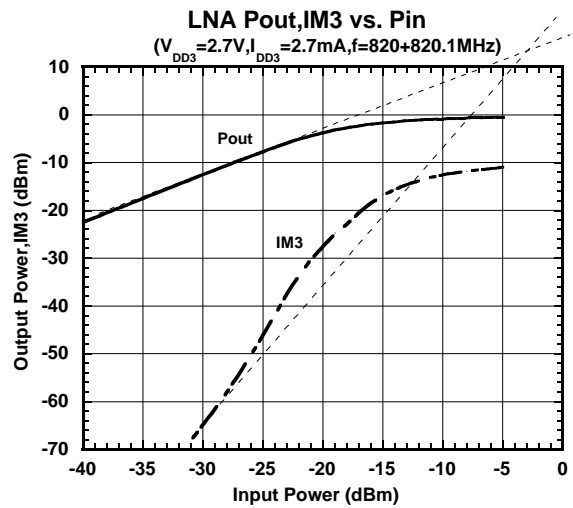
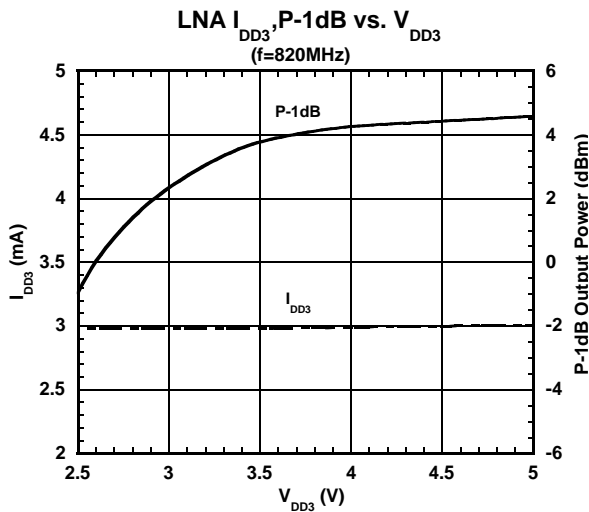
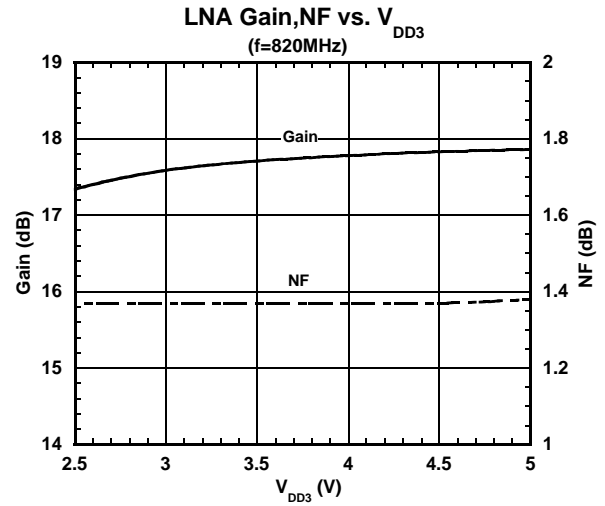
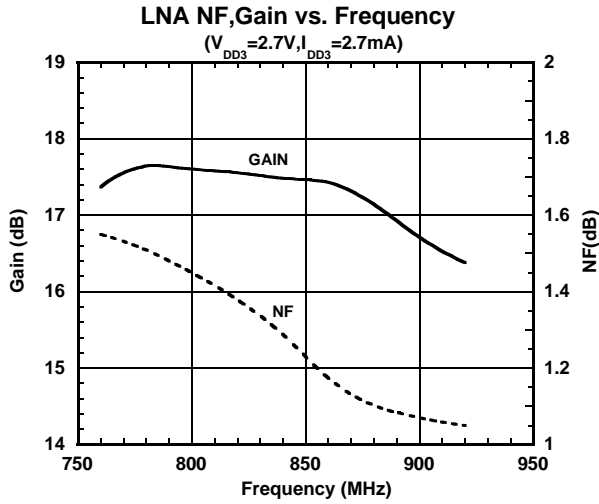

NJG1707PG1

TYPICAL CHARACTERISTICS (LNA)

Measured on the PCB evaluation circuit. $V_{DD3}=2.7V$

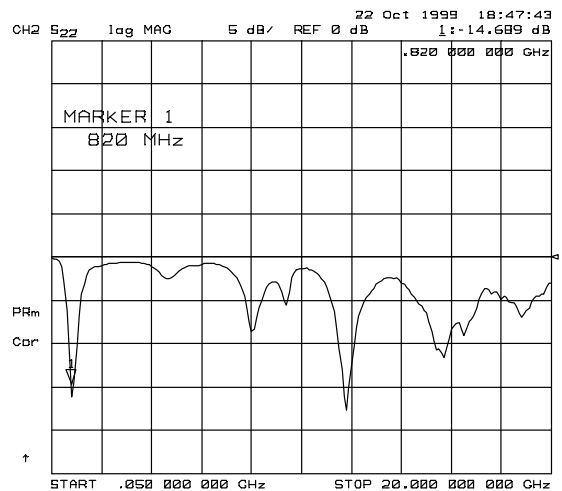
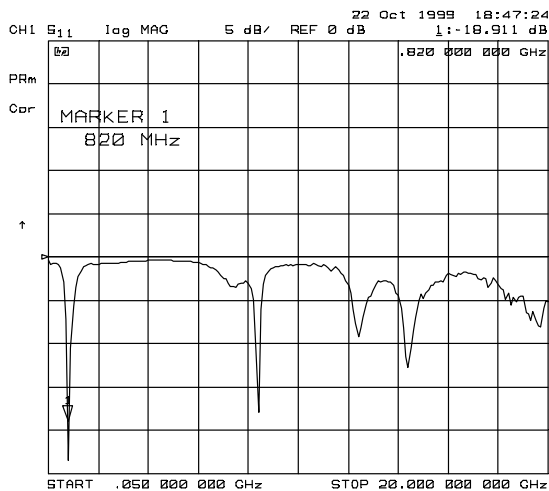
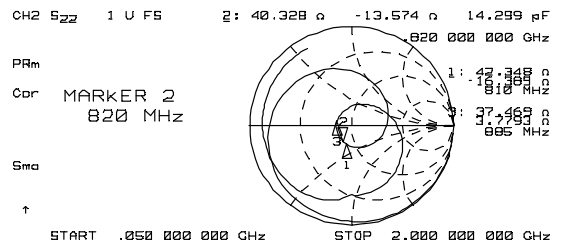
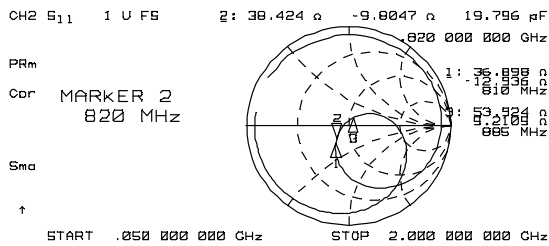
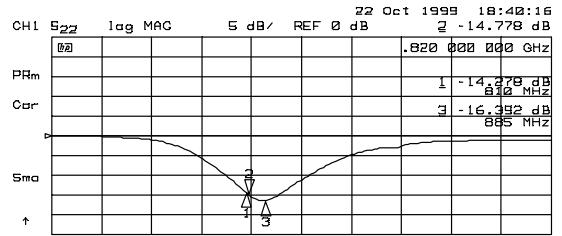
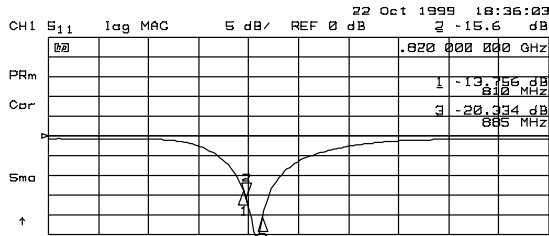
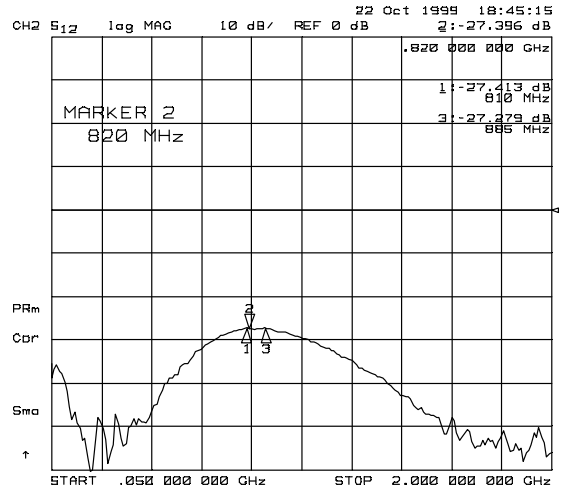
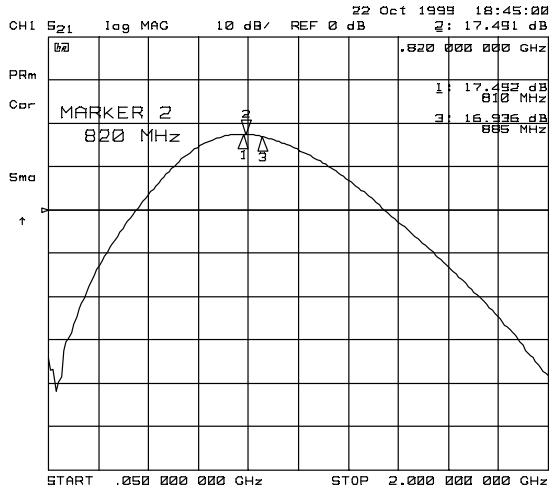

■ TYPICAL CHARACTERISTICS (LNA)

Measured on the PCB evaluation circuit.

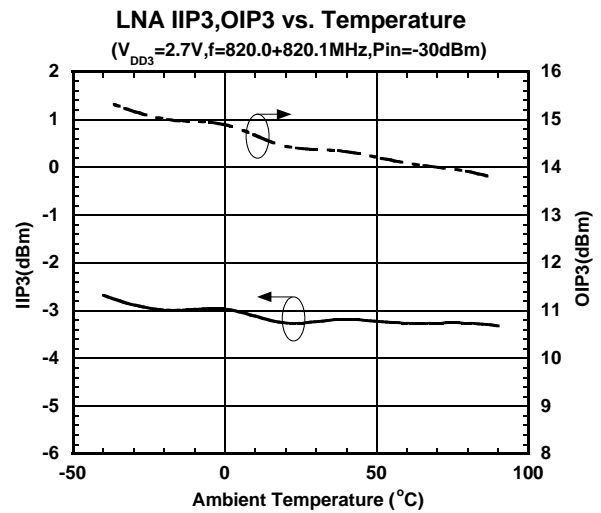
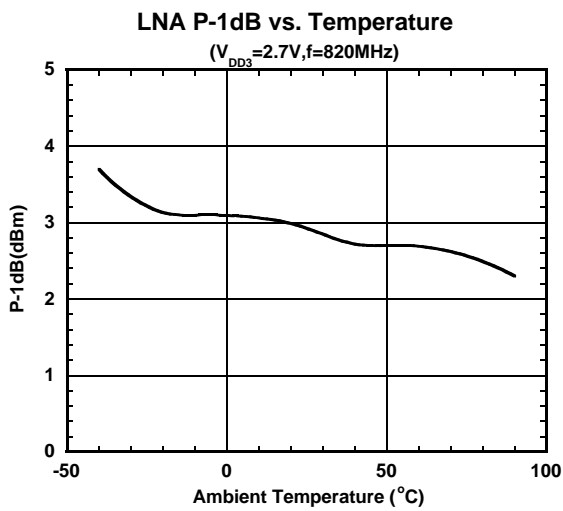
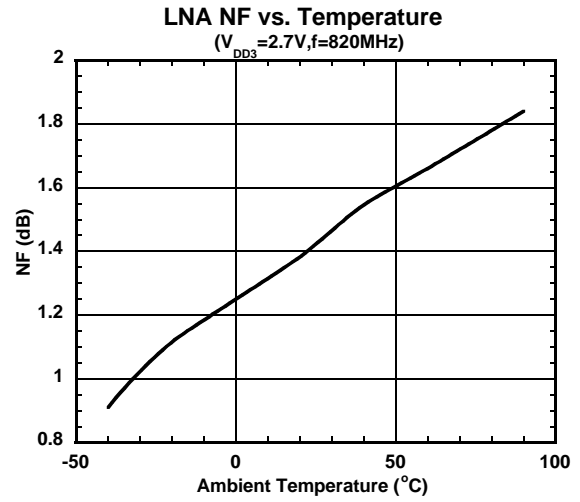
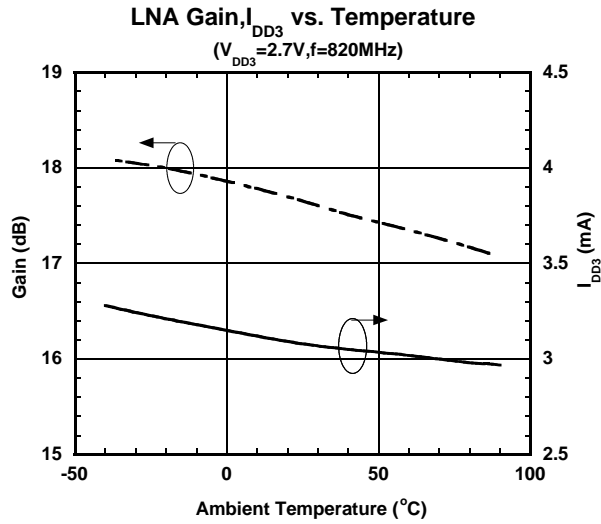

NJG1707PG1

■TYPICAL CHARACTERISTICS (LNA)

LNA Scattering Parameter Table

Freq. (GHz)	S11		S21		S12		S22	
	mag. (unit)	ang. (deg.)	mag. (unit)	ang. (deg.)	mag. (unit)	ang. (deg.)	mag. (unit)	ang. (deg.)
0.1	1.000	-2.22	2.147	176.00	0.009	48.67	0.949	-1.04
0.2	0.987	-5.10	2.087	168.16	0.008	38.98	0.940	-3.71
0.3	0.985	-7.12	2.053	161.77	0.005	68.44	0.954	-4.61
0.4	0.987	-10.49	2.079	154.25	0.010	61.48	0.940	-7.50
0.5	0.967	-12.19	2.020	147.74	0.008	58.51	0.939	-8.86
0.6	0.967	-15.33	1.998	141.28	0.007	57.29	0.931	-11.32
0.7	0.943	-17.89	1.947	134.57	0.010	62.79	0.921	-13.70
0.8	0.928	-20.65	1.899	128.63	0.010	57.35	0.918	-15.28
0.9	0.911	-23.45	1.845	122.18	0.013	61.22	0.924	-18.33
1	0.894	-26.19	1.795	116.45	0.013	64.15	0.914	-20.15
1.1	0.882	-28.43	1.723	111.16	0.013	68.15	0.923	-22.40
1.2	0.867	-30.91	1.675	105.79	0.014	66.63	0.910	-24.64
1.3	0.861	-33.29	1.613	100.76	0.014	69.43	0.927	-26.98
1.4	0.853	-35.74	1.556	95.80	0.015	65.80	0.916	-28.74
1.5	0.848	-37.65	1.498	90.90	0.015	69.41	0.921	-30.73
1.6	0.843	-39.63	1.442	86.45	0.017	75.17	0.915	-32.14
1.7	0.834	-41.23	1.384	82.25	0.018	76.93	0.913	-33.86
1.8	0.832	-42.72	1.344	78.49	0.018	80.33	0.913	-35.13
1.9	0.823	-43.91	1.288	74.67	0.021	84.19	0.908	-36.37
2	0.816	-44.93	1.253	71.30	0.022	82.05	0.912	-37.14

$V_{DD3}=2.7V$, $I_{DD3}=3mA$, $Z_0=50\Omega$

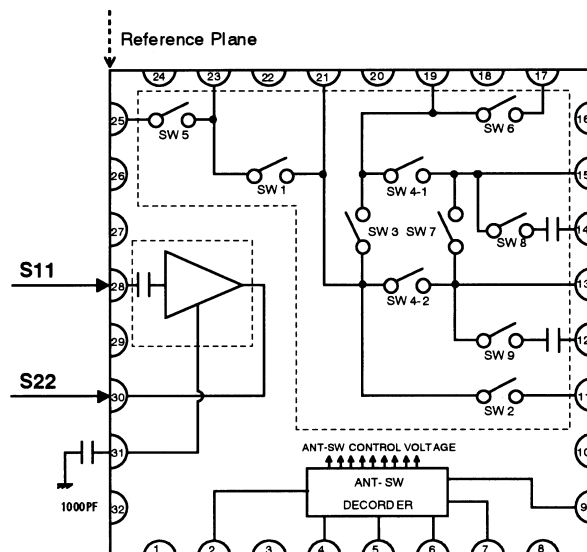

RECOMMENDED CIRCUIT (Tx-ANT1 PASSING)

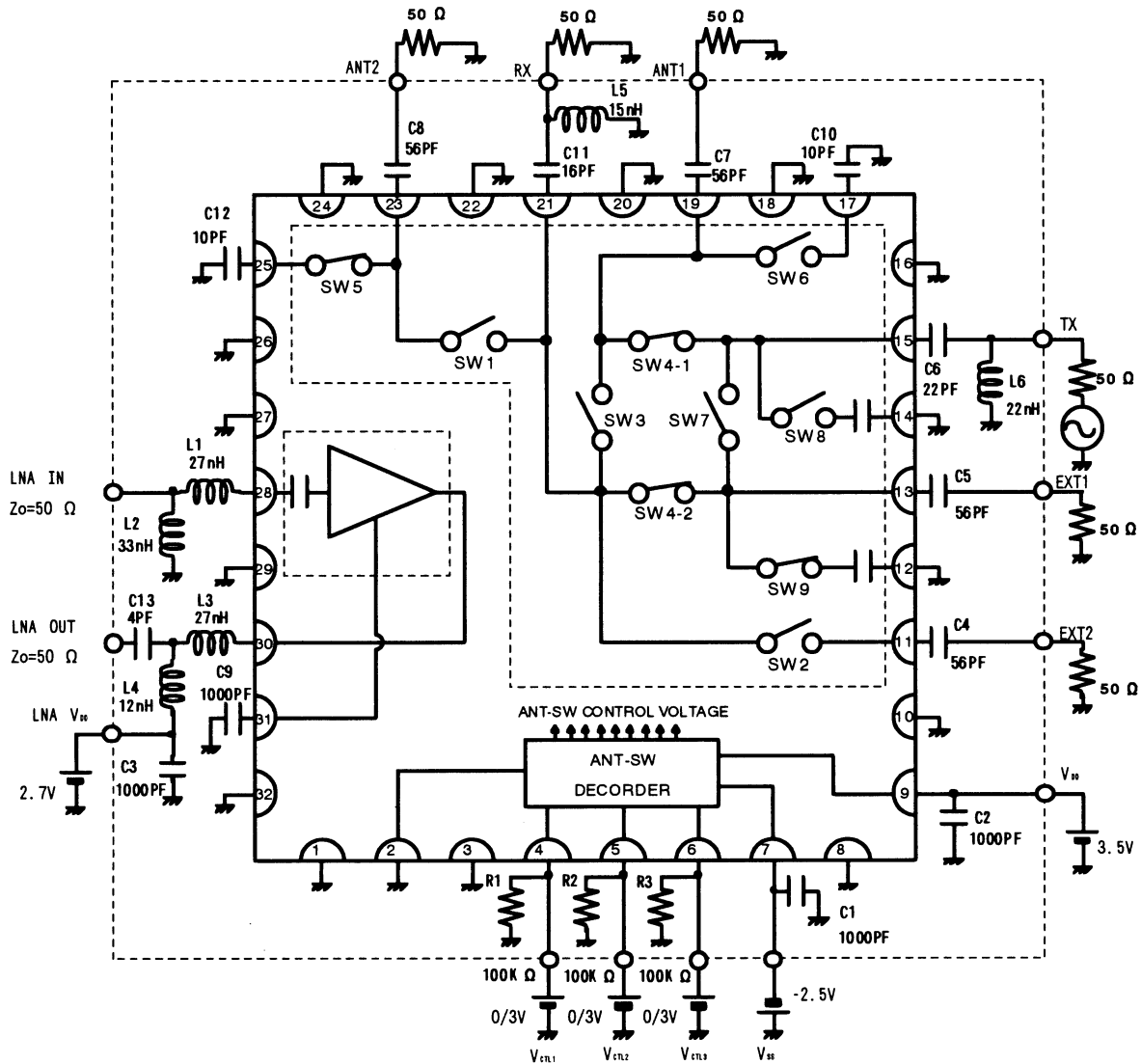

PRECAUTIONS

Please connect resistors R1~R3 between VCTL1~VCTL3 terminals (Pin#4, 5, 6) and GND or V_{DD} only when CTL1~CTL3 voltage is required to clip to H or L level.

NJG1707PG1

RECOMMENDED PCB DESIGN

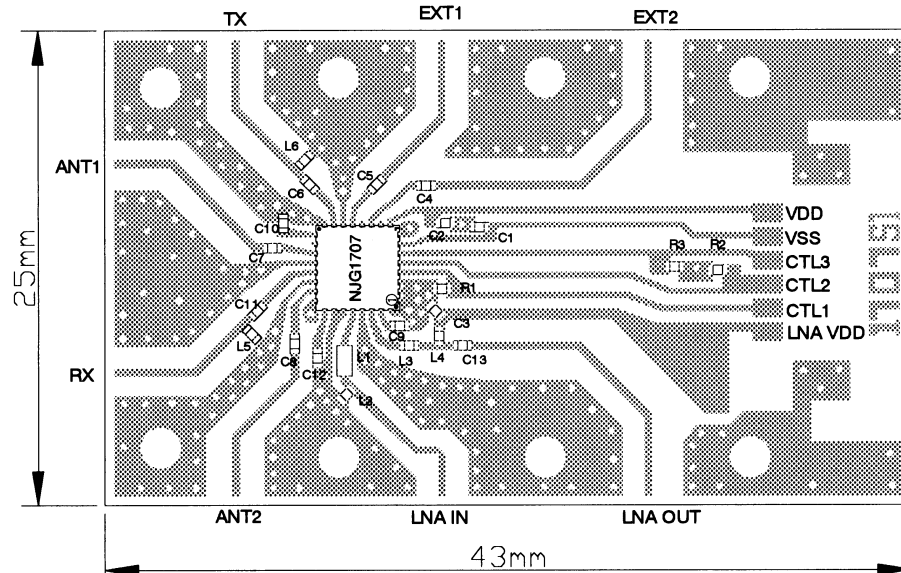

PCB: FR-4, t= 0.2mm
Stripline width: 0.4mm

Board total loss (Capacitors, Connectors, and PCB)

Pass route	800MHz band (dB)	Frequency (MHz)
TX-ANT1	0.30	960
TX-EXT1	0.26	
RX-ANT1	0.28	885
RX-ANT2	0.29	
RX-EXT1	0.32	
RX-EXT2	0.37	

PARTS LIST

PARTS ID	VALUE	COMMENT
R1-R3	100Ω	1005 Size
C1~3, C9	1000pF	MURATA(GRM36)
C4, C5, C7, C8	22pF	MURATA(GRM36)
C10, C12	10pF	MURATA(GRM36)
C11	16pF	MURATA(GRM36)
C13	4pF	MURATA(GRM36)
L1	27nH	TAIYO-YUDEN(HK1608)
L2	33nH	TAIYO-YUDEN(HK1005)
L3	27nH	TAIYO-YUDEN(HK1005)
L4	12nH	TAIYO-YUDEN(HK1005)
L5	15nH	TAIYO-YUDEN(HK1005)
L6	22nH	TAIYO-YUDEN(HK1005)

PRECAUTIONS

- [1] The bypass capacitors should be connected to the V_{DD} , V_{SS} terminals as close as possible respectively.
- [2] For good RF performance, the ground terminals should be directly connected to the ground patterns and through-holes as close as possible by using relatively wide pattern.

PACKAGE OUTLINE (FFP32-G1)

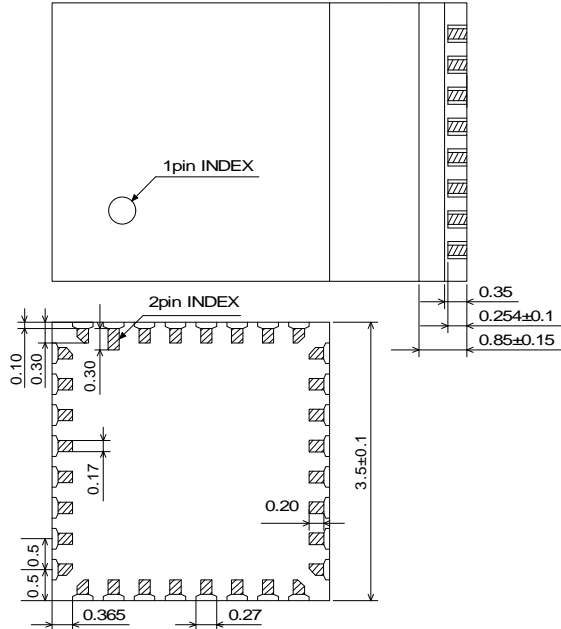

UNITS	: mm
PCB	: Ceramic
OVER COAT	: Epoxy resin
LEAD SURFACE	: Au
WEIGHT	: 30mg

Cautions on using this product

This product contains Gallium-Arsenide (GaAs) which is a harmful material.

- Do NOT eat or put into mouth.
- Do NOT dispose in fire or break up this product.
- Do NOT chemically make gas or powder with this product.
- To waste this product, please obey the relating law of your country.

[CAUTION]

The specifications on this databook are only given for information, without any guarantee as regards either mistakes or omissions. The application circuits in this databook are described only to show representative usages of the product and not intended for the guarantee or permission of any right including the industrial rights.

This product may be damaged with electric static discharge (ESD) or spike voltage. Please handle