HM5212325F-B60

128M LVTTL interface SDRAM
100 MHz
1-Mword × 32-bit × 4-bank
PC/100 SDRAM

HITACHI

ADE-203-1053A (Z)
Rev. 1.0
Oct. 18, 1999

Description

The Hitachi HM5212325F is a 128-Mbit SDRAM organized as 1048576-word × 32-bit × 4-bank. All inputs and outputs are referred to the rising edge of the clock input. It is packaged in standard 108 bump BGA.

Features

- Single chip wide bit solution (× 32)
- 3.3 V power supply
- Clock frequency: 100 MHz (max)
- LVTTL interface
- Extremely small foot print: 1.27 mm pitch
 - Package: BGA (BP-108)
- 4 banks can operate simultaneously and independently
- Burst read/write operation and burst read/single write operation capability
- Programmable burst length: 4/8/full page
- 2 variations of burst sequence
 - Sequential (BL = 4/8/full page)
 - Interleave (BL = 4/8)
- Programmable $\overline{\text{CAS}}$ latency: 2/3
- Byte control by DQMB
- Refresh cycles: 4096 refresh cycles/64 ms
- 2 variations of refresh
 - Auto refresh
 - Self refresh



HM5212325F-B60

- Full page burst length capability
 - Sequential burst
 - Burst stop capability

Ordering Information

Type No.	Frequency	$\overline{\text{CAS}}$ latency	Package
HM5212325FBP-B60*	100 MHz	3	14 mm × 22 mm 108 bump BGA (BP-108)

Note: 66 MHz operation at $\overline{\text{CAS}}$ latency = 2.

Pin Arrangement

108-bump BGA

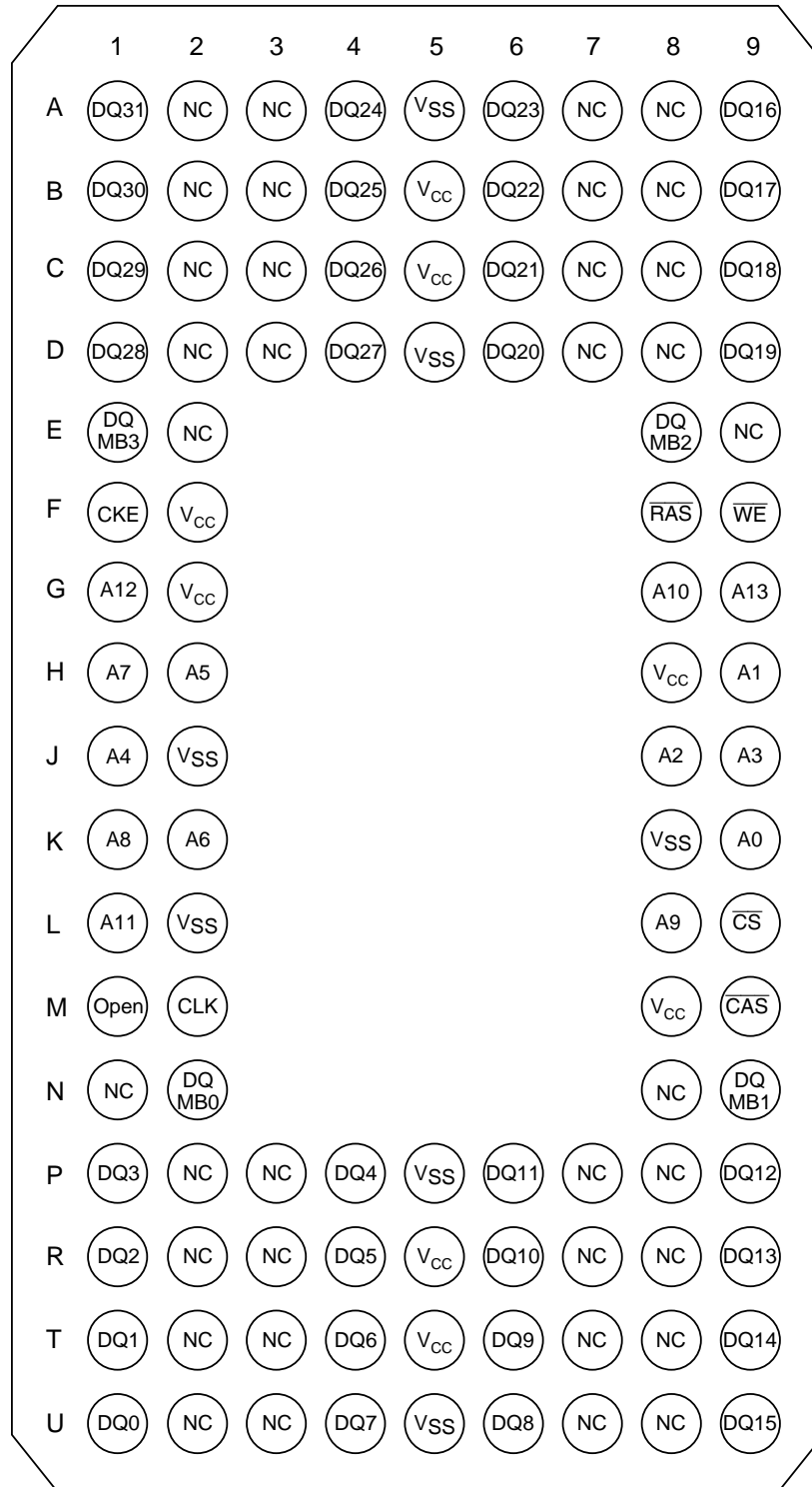

(Top view)

Pin Description

Pin name	Function
A0 to A13	Address input Row address A0 to A11 Column address A0 to A7 Bank select address A12/A13 (BS)
DQ0 to DQ31	Data-input/output
$\overline{\text{CS}}$	Chip select
$\overline{\text{RAS}}$	Row address strobe command
$\overline{\text{CAS}}$	Column address strobe command
$\overline{\text{WE}}$	Write enable
DQMB0 to DQMB3	Byte data mask* ¹
CLK	Clock input
CKE	Clock enable
V _{CC}	Power supply
V _{SS}	Ground
Open	Open* ²

- Note:
1. DQMB0: DQ0 to DQ7
DQMB1: DQ8 to DQ15
DQMB2: DQ16 to DQ23
DQMB3: DQ24 to DQ31
 2. Don't connect. Internally connected with die.

Block Diagram

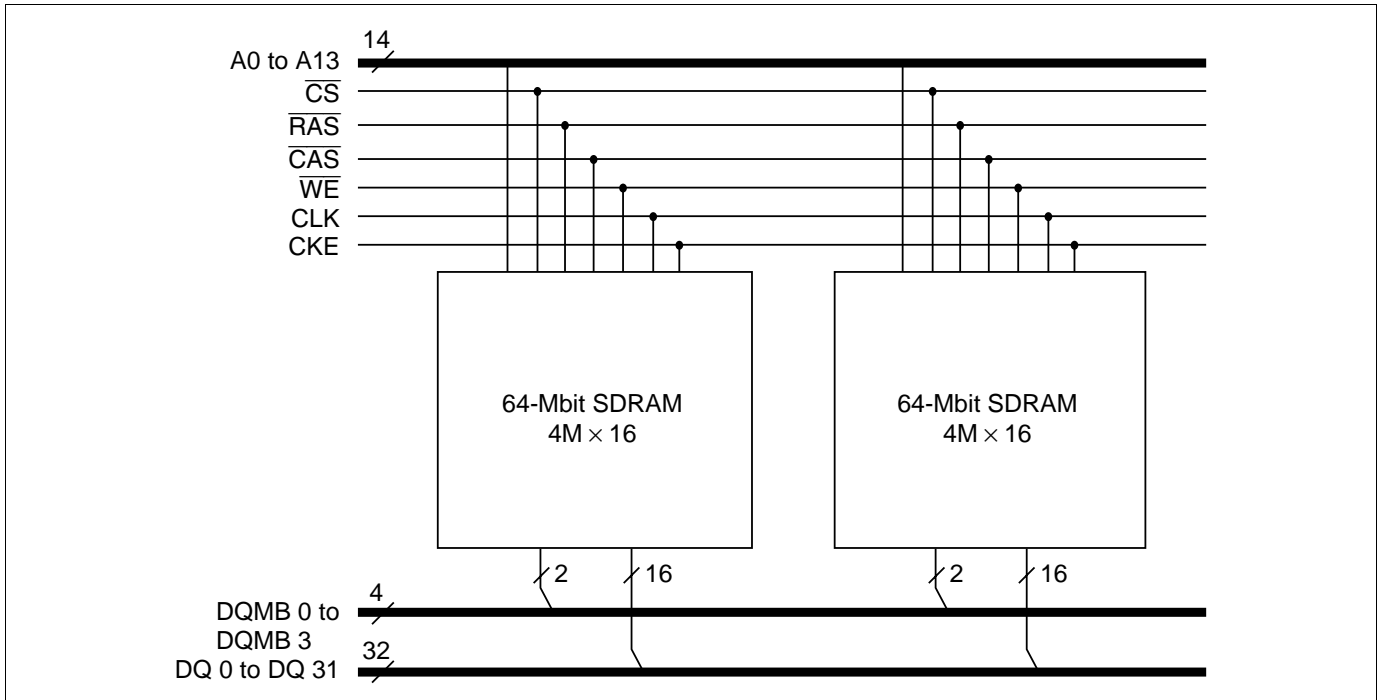

Power-up Sequence and Initialization Sequence

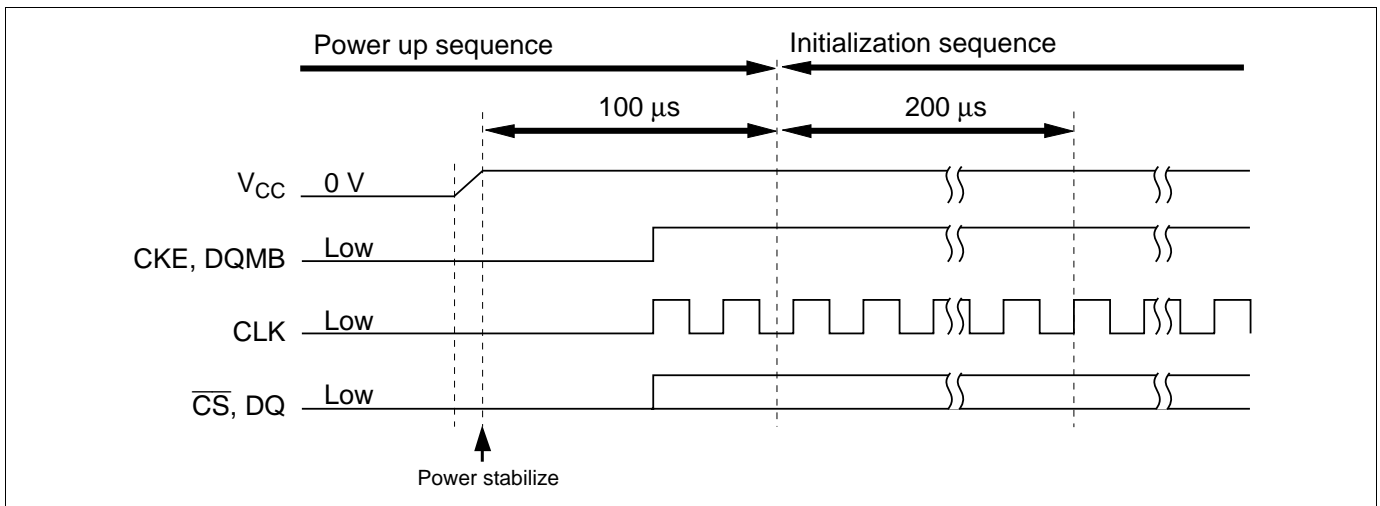

Absolute Maximum Ratings

Parameter	Symbol	Value	Unit	Note
Voltage on any pin relative to V_{SS}	V_T	-0.5 to $V_{CC} + 0.5$ (≤ 4.6 (max))	V	1
Supply voltage relative to V_{SS}	V_{CC}	-0.5 to +4.6	V	1
Short circuit output current	I_{out}	50	mA	
Operating temperature	T_{opr}	0 to +70 (T_j max = 110)	°C	
Storage temperature	T_{stg}	-55 to +125	°C	

Note: 1. Respect to V_{SS} .

DC Operating Conditions ($T_{case} = 0$ to +70°C [T_j max = 110°C])

Parameter	Symbol	Min	Max	Unit	Notes
Supply voltage	V_{CC}	3.0	3.6	V	1, 2
	V_{SS}	0	0	V	3
Input high voltage	V_{IH}	2.0	$V_{CC} + 0.3$	V	1, 4
Input low voltage	V_{IL}	-0.3	0.8	V	1, 5

Notes: 1. All voltage referred to V_{SS} .

2. The supply voltage with all V_{CC} pins must be on the same level.
3. The supply voltage with all V_{SS} pins must be on the same level.
4. V_{IH} (max) = $V_{CC} + 2.0$ V for pulse width ≤ 3 ns at V_{CC} .
5. V_{IL} (min) = $V_{SS} - 2.0$ V for pulse width ≤ 3 ns at V_{SS} .

DC Characteristics(T_{case} = 0 to +70°C [T_j max = 110°C]), V_{CC} = 3.3 V ± 0.3 V, V_{SS} = 0 V)

Parameter	Symbol	HM5212325F		Unit	Test conditions	Notes
		Min	Max			
Operating current ($\overline{\text{CAS}}$ latency = 2)	I _{CC1}	—	100	mA	Burst length = 1 t _{RC} = min	1, 2, 3
	I _{CC1}	—	110			
Standby current in power down	I _{CC2P}	—	6	mA	CKE = V _{IL} , t _{CK} = 12 ns	6
Standby current in power down (input signal stable)	I _{CC2PS}	—	4			
Standby current in non power down	I _{CC2N}	—	32	mA	CKE, $\overline{\text{CS}}$ = V _{IH} , t _{CK} = 12 ns	4
Standby current in non power down (input signal stable)	I _{CC2NS}	—	18			
Active standby current in power down	I _{CC3P}	—	8	mA	CKE = V _{IL} , t _{CK} = 12 ns	1, 2, 6
Active standby current in power down (input signal stable)	I _{CC3PS}	—	6			
Active standby current in non power down	I _{CC3N}	—	40	mA	CKE, $\overline{\text{CS}}$ = V _{IH} , t _{CK} = 12 ns	1, 2, 4
Active standby current in non power down (input signal stable)	I _{CC3NS}	—	30			
Burst operating current ($\overline{\text{CAS}}$ latency = 2)	I _{CC4}	—	110	mA	t _{CK} = min, BL = 4	1, 2, 5
	I _{CC4}	—	135			
Refresh current	I _{CC5}	—	190	mA	t _{RC} = min	3
Self refresh current	I _{CC6}	—	2			
Self refresh current (L-version)	I _{CC6}	—	0.8	mA	V _{IH} ≥ V _{CC} - 0.2 V V _{IL} ≤ 0.2 V	8
Input leakage current	I _{LI}	-4	4			
Output leakage current	I _{LO}	-6	6	μA	0 ≤ V _{out} ≤ V _{CC} DQ = disable	
Output high voltage	V _{OH}	2.4	—			
Output low voltage	V _{OL}	—	0.4	V	I _{OL} = 4 mA	

HM5212325F-B60

- Notes:
1. I_{CC} depends on output load condition when the device is selected. I_{CC} (max) is specified at the output open condition.
 2. One bank operation.
 3. Input signals are changed once per one clock.
 4. Input signals are changed once per two clocks.
 5. Input signals are changed once per four clocks.
 6. After power down mode, CLK operating current.
 7. After power down mode, no CLK operating current.
 8. After self refresh mode set, self refresh current.
 9. Input signals are V_{IH} or V_{IL} fixed.

Capacitance ($T_a = 25^\circ\text{C}$, $V_{CC} = 3.3\text{ V} \pm 0.3\text{ V}$)

Parameter	Symbol	Min	Max	Unit	Notes
Input capacitance (CLK)	C_{I1}	5	8	pF	1, 2, 4
Input capacitance (Input except DQM)	C_{I2}	5	8	pF	1, 2, 4
Input capacitance (DQM)	C_{I3}	2.5	5	pF	1, 2, 4
Output capacitance (DQ)	C_O	3	5	pF	1, 2, 3, 4

- Notes:
1. Capacitance measured with Boonton Meter or effective capacitance measuring method.
 2. Measurement condition: $f = 1\text{ MHz}$, 1.4 V bias, 200 mV swing.
 3. $DQMB = V_{IH}$ to disable Dout.
 4. This parameter is sampled and not 100% tested.

AC Characteristics(T_{case} = 0 to +70°C [T_j max = 110°C]), V_{CC} = 3.3 V ± 0.3 V, V_{SS} = 0 V)

Parameter	HITACHI Symbol	PC/100 Symbol	HM5212325F		Unit	Notes
			Min	Max		
System clock cycle time ($\overline{\text{CAS}}$ latency = 2)	t _{CK}	Tclk	15	—	ns	1
($\overline{\text{CAS}}$ latency = 3)	t _{CK}	Tclk	10	—	ns	
CLK high pulse width	t _{CKH}	Tch	3	—	ns	1
CLK low pulse width	t _{CKL}	Tcl	3	—	ns	1
Access time from CLK ($\overline{\text{CAS}}$ latency = 2)	t _{AC}	Tac	—	8	ns	1, 2
($\overline{\text{CAS}}$ latency = 3)	t _{AC}	Tac	—	6	ns	
Data-out hold time	t _{OH}	Toh	3	—	ns	1, 2
CLK to Data-out low impedance	t _{LZ}		2	—	ns	1, 2, 3
CLK to Data-out high impedance	t _{HZ}		—	6	ns	1, 4
Input setup time	t _{AS} , t _{CS} , t _{DS} , t _{CES}	Tsi	2	—	ns	1, 5, 6
CKE setup time for power down exit	t _{CESP}	Tpde	2	—	ns	1
Input hold time	t _{AH} , t _{CH} , t _{DH} , t _{CEH}	Thi	1	—	ns	1, 5
Ref/Active to Ref/Active command period	t _{RC}	Trc	70	—	ns	1
Active to Precharge command period	t _{RAS}	Tras	50	120000	ns	1
Active command to column command (same bank)	t _{RCD}	Trcd	20	—	ns	1
Precharge to active command period	t _{RP}	Trp	20	—	ns	1
Write recovery or data-in to precharge lead time	t _{DPL}	Tdpl	10	—	ns	1
Active (a) to Active (b) command period	t _{RRD}	Trrd	20	—	ns	1
Transition time (rise and fall)	t _T		1	5	ns	
Refresh period	t _{REF}		—	64	ms	

HM5212325F-B60

- Notes:
1. AC measurement assumes $t_T = 1$ ns. Reference level for timing of input signals is 1.5 V.
 2. Access time is measured at 1.5 V. Load condition is $CL = 50$ pF.
 3. t_{LZ} (min) defines the time at which the outputs achieves the low impedance state.
 4. t_{HZ} (max) defines the time at which the outputs achieves the high impedance state.
 5. t_{CES} define CKE setup time to CLK rising edge except power down exit command.
 6. t_{AS}/t_{AH} : Address, t_{CS}/t_{CH} : \overline{CS} , \overline{RAS} , \overline{CAS} , \overline{WE} , \overline{DQM} .
 t_{DS}/t_{DH} : Data-in, t_{CES}/t_{CEH} : CKE

Test Conditions

- Input and output timing reference levels: 1.5 V
- Input waveform and output load: See following figures

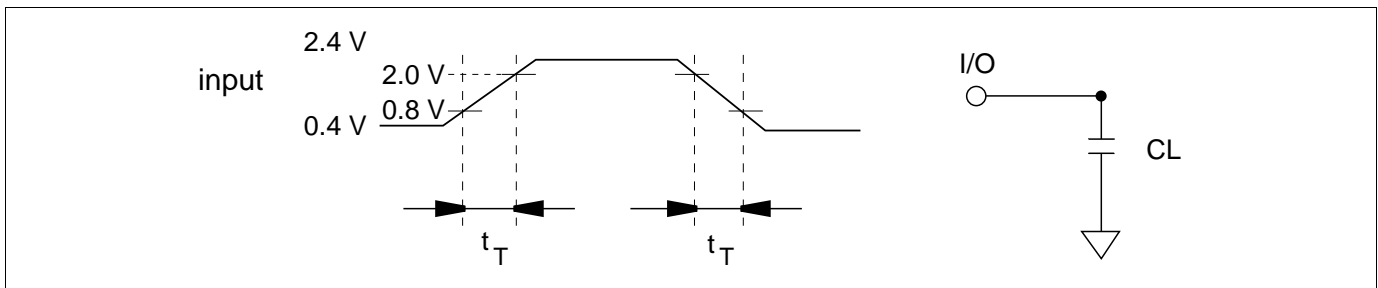

Package Dimensions

HM5212325FBP Series (BP-108)

Preliminary

Unit: mm

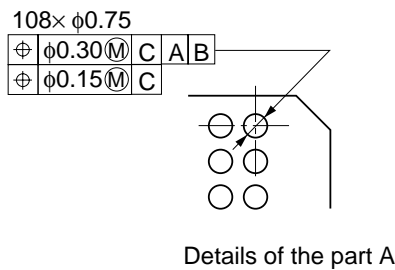
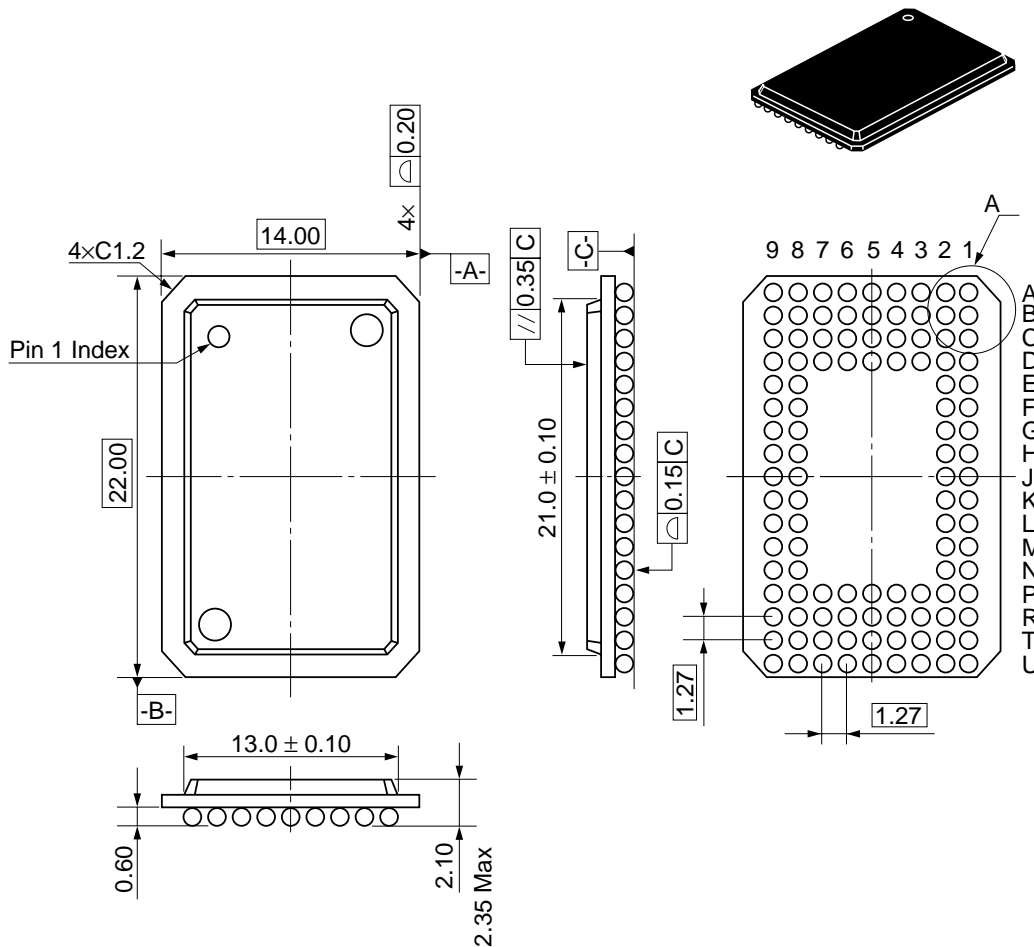

Hitachi Code	BP-108
JEDEC	—
EIAJ	—
Weight (reference value)	1.2 g

Cautions

1. Hitachi neither warrants nor grants licenses of any rights of Hitachi's or any third party's patent, copyright, trademark, or other intellectual property rights for information contained in this document. Hitachi bears no responsibility for problems that may arise with third party's rights, including intellectual property rights, in connection with use of the information contained in this document.
2. Products and product specifications may be subject to change without notice. Confirm that you have received the latest product standards or specifications before final design, purchase or use.
3. Hitachi makes every attempt to ensure that its products are of high quality and reliability. However, contact Hitachi's sales office before using the product in an application that demands especially high quality and reliability or where its failure or malfunction may directly threaten human life or cause risk of bodily injury, such as aerospace, aeronautics, nuclear power, combustion control, transportation, traffic, safety equipment or medical equipment for life support.
4. Design your application so that the product is used within the ranges guaranteed by Hitachi particularly for maximum rating, operating supply voltage range, heat radiation characteristics, installation conditions and other characteristics. Hitachi bears no responsibility for failure or damage when used beyond the guaranteed ranges. Even within the guaranteed ranges, consider normally foreseeable failure rates or failure modes in semiconductor devices and employ systemic measures such as fail-safes, so that the equipment incorporating Hitachi product does not cause bodily injury, fire or other consequential damage due to operation of the Hitachi product.
5. This product is not designed to be radiation resistant.
6. No one is permitted to reproduce or duplicate, in any form, the whole or part of this document without written approval from Hitachi.
7. Contact Hitachi's sales office for any questions regarding this document or Hitachi semiconductor products.

HITACHI

Hitachi, Ltd.

Semiconductor & Integrated Circuits.

Nippon Bldg., 2-6-2, Ohte-machi, Chiyoda-ku, Tokyo 100-0004, Japan

Tel: Tokyo (03) 3270-2111 Fax: (03) 3270-5109

URL NorthAmerica : <http://semiconductor.hitachi.com/>
 Europe : <http://www.hitachi-eu.com/hel/ecg>
 Asia (Singapore) : <http://www.has.hitachi.com.sg/grp3/sicd/index.htm>
 Asia (Taiwan) : http://www.hitachi.com.tw/E/Product/SICD_Frame.htm
 Asia (HongKong) : <http://www.hitachi.com.hk/eng/bo/grp3/index.htm>
 Japan : <http://www.hitachi.co.jp/Sicd/indx.htm>

For further information write to:

Hitachi Semiconductor
(America) Inc.
179 East Tasman Drive,
San Jose, CA 95134
Tel: <1> (408) 433-1990
Fax: <1> (408) 433-0223

Hitachi Europe GmbH
Electronic components Group
Dornacher Straße 3
D-85622 Feldkirchen, Munich
Germany
Tel: <49> (89) 9 9180-0
Fax: <49> (89) 9 29 30 00

Hitachi Europe Ltd.
Electronic Components Group.
Whitebrook Park
Lower Cookham Road
Maidenhead
Berkshire SL6 8YA, United Kingdom
Tel: <44> (1628) 585000
Fax: <44> (1628) 778322

Hitachi Asia Pte. Ltd.
16 Collyer Quay #20-00
Hitachi Tower
Singapore 049318
Tel: 535-2100
Fax: 535-1533

Hitachi Asia Ltd.
Taipei Branch Office
3F, Hung Kuo Building, No.167,
Tun-Hwa North Road, Taipei (105)
Tel: <886> (2) 2718-3666
Fax: <886> (2) 2718-8180

Hitachi Asia (Hong Kong) Ltd.
Group III (Electronic Components)
7/F., North Tower, World Finance Centre,
Harbour City, Canton Road, Tsim Sha Tsui,
Kowloon, Hong Kong
Tel: <852> (2) 735 9218
Fax: <852> (2) 730 0281
Telex: 40815 HITEC HX

Copyright © Hitachi, Ltd., 1998. All rights reserved. Printed in Japan.

Revision Record

Rev.	Date	Contents of Modification	Drawn by	Approved by
0.0	May. 12, 1999	Initial issue	S. Hatano	S. Hatano
1.0	Oct. 18, 1999	Programmable $\overline{\text{CAS}}$ latency: 3 to 2/3 Ordering information Addition of note Pin description Addition of note 1 DC Characteristics I_{CC1} max (CL = 3): 150 mA to 110 mA I_{CC4} max (CL = 3): 180 mA to 135 mA I_{CC5} max: 230 mA to 190 mA Addition of I_{CC1} max (CL = 2): 100 mA Addition of I_{CC4} max (CL = 2): 110 mA Capacitance C_{12} max: 10 pF to 8 pF C_{13} max: 6 pF to 5 pF C_{O} min: 4 pF to 3 pF C_{O} max: 6.5 pF to 5 pF AC Characteristics Addition of t_{CK} min (CL = 2): 15 ns Addition of t_{AC} max (CL = 2): 8 ns Package dimension Change tolerance of height		