

800MHz BAND MIXER GaAs MMIC

■GENERAL DESCRIPTION

NJG1551F is a mixer GaAs MMIC featured low distortion, high conversion gain and low noise figure.

NJG1551F includes a mixer and a local amplifier, and ideally suitable for 800MHz band digital mobile phone handsets.

The very small MTP package is adopted.

■PACKAGE OUTLINE

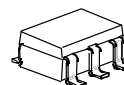

NJG1551F

■FEATURES

- Low voltage operation
- High conversion gain
- High IP3

+2.7V
 13dB typ. @ $f_{RF}=820\text{MHz}$, $P_{LO}=-10\text{dBm}$, $P_{RF}=-30\text{dBm}$
 OIP3=12dBm typ. @ $f_{RF1}=820.0\text{MHz}$, $f_{RF2}=820.1\text{MHz}$
 $P_{LO}=-10\text{dBm}$, $P_{RF}=-30\text{dBm}$
 IIP3=-1dBm typ. @ $f_{RF1}=820.0\text{MHz}$, $f_{RF2}=820.1\text{MHz}$
 $P_{LO}=-10\text{dBm}$, $P_{RF}=-30\text{dBm}$
 5dB typ. @ $f_{RF}=820\text{MHz}$, $P_{LO}=-10\text{dBm}$
 MTP6 (Mount Size: 2.8x2.9x1.2mm)

- Low noise figure
- Package

■PIN CONFIGURATION

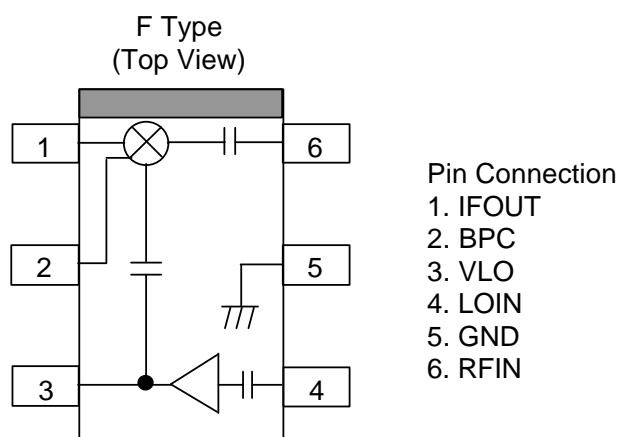

NOTE :The portion above shows orientation mark printed on the package surface.

NJG1551F

■ABSOLUTE MAXIMUM RATINGS

($T_a=25^{\circ}\text{C}$, $Z_s=Z_l=50\Omega$)

PARAMETERS	SYMBOL	CONDITIONS	RATINGS	UNITS
Mixer Supply Voltage	V_{MIX}		5	V
Local Amplifier Supply Voltage	V_{LO}		5	V
Mixer RF Input Power	P_{RFIN}	$V_{\text{MIX}}=2.7\text{V}$, $V_{\text{LO}}=2.7\text{V}$	10	dBm
Mixer LO Input Power	P_{LOIN}	$V_{\text{MIX}}=2.7\text{V}$, $V_{\text{LO}}=2.7\text{V}$	10	dBm
Power Dissipation	P_{D}		150	mW
Operating Temp.	T_{opr}		-30~+85	$^{\circ}\text{C}$
Storage Temp.	T_{stg}		-40~+150	$^{\circ}\text{C}$

■RECOMMENDED OPERATING RANGE

PARAMETER	SYMBOL	MIN	TYP	MAX	UNITS
Mixer Supply Voltage	V_{MIX}	2.5	2.7	4.5	V
Local Amplifier Supply Voltage	V_{LO}	2.5	2.7	4.5	V

■ELECTRICAL CHARACTERISTICS

($T_a=25^{\circ}\text{C}$, $V_{\text{MIX}}=2.7\text{V}$, $V_{\text{LO}}=2.7\text{V}$, $f_{\text{IF}}=130\text{MHz}$, $P_{\text{LO}}=-10\text{dBm}$)

PARAMETERS	SYMBOL	CONDITIONS	MIN	TYP	MAX	UNITS
Mixer Current	I_{MIX}	$P_{\text{RF}}=\text{OFF}$, $P_{\text{LO}}=\text{OFF}$	-	5.0	7.0	mA
Local Amplifier Current	I_{LO}	$P_{\text{RF}}=\text{OFF}$, $P_{\text{LO}}=\text{OFF}$	-	2.0	3.2	mA
Conversion Gain	G_{C}	$f_{\text{RF}}=820\text{MHz}$, $P_{\text{RF}}=-30\text{dBm}$ $f_{\text{LO}}=690\text{MHz}$	9.5	13.0	-	dB
Input 3rd Order Intercept Point	IIP3	$f_{\text{RF}}=820.0\text{MHz}+820.1\text{MHz}$ $f_{\text{LO}}=690\text{MHz}$	-	-1.0	-	dBm
Noise Figure	NF	$f_{\text{RF}}=820\text{MHz}$ $f_{\text{LO}}=690\text{MHz}$	-	5.0	6.0	dB

■ TYPICAL CHARACTERISTICS (Application 1, $f_{LO}=690\text{MHz}$)

Conversion Gain , Noise Figure vs. LO Power

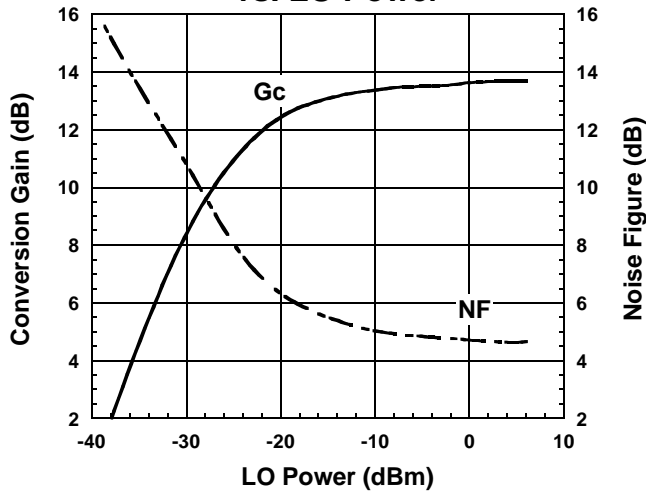

Condition
 $f_{IF}=130\text{MHz}$
 $f_{RF1}=820\text{MHz}$, $P_{RF}=-30\text{dBm}$
 $f_{LO}=690\text{MHz}$
 $V_{MIX}=V_{LO}=2.7\text{V}$

IF , IM3 , IM5 vs. RF Power

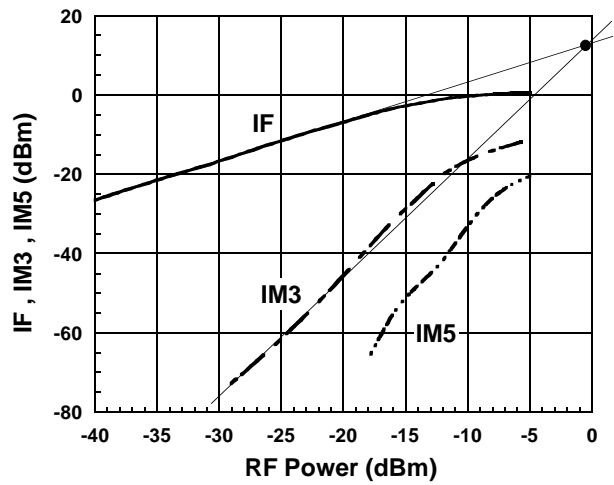

Condition
 $f_{IF}=130\text{MHz}$
 $f_{RF1}=820.0\text{MHz}$
 $f_{RF2}=820.1\text{MHz}$
 $f_{LO}=690\text{MHz}$, $P_{LO}=-10\text{dBm}$
 $V_{MIX}=V_{LO}=2.7\text{V}$

Input-IP3 vs. LO Power

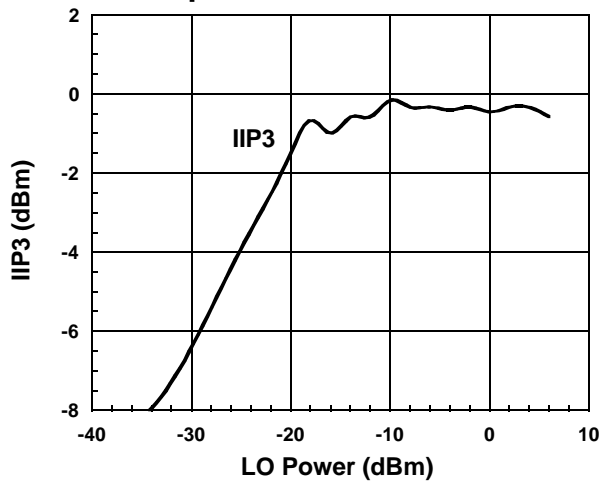

Condition
 $f_{IF}=130\text{MHz}$
 $f_{RF1}=820.0\text{MHz}$, $P_{RF}=-30\text{dBm}$
 $f_{RF2}=820.1\text{MHz}$
 $f_{LO}=690\text{MHz}$
 $V_{MIX}=V_{LO}=2.7\text{V}$

$$\text{IIP3} = \frac{3\text{IF}-\text{IM3}}{2} - G_c$$
 @ $P_{RF}=-27\text{dBm}$

Conversion Gain , Noise Figure , Input-IP3 vs. V_{MIX} , V_{LO}

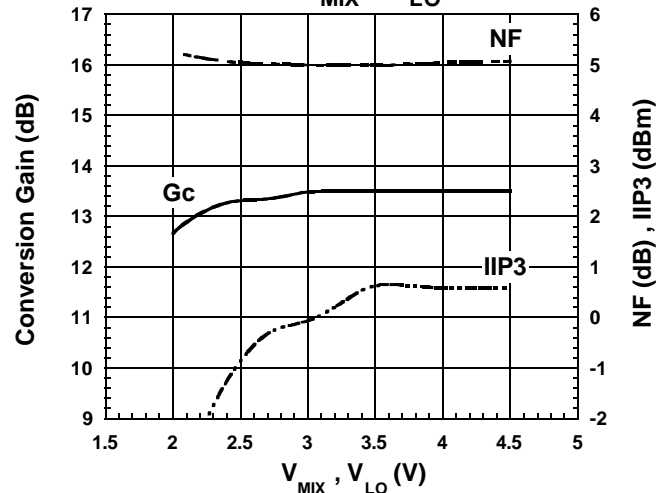

Condition
 $f_{IF}=130\text{MHz}$
 $f_{RF1}=820.0\text{MHz}$, $P_{RF}=-30\text{dBm}$
 $f_{RF2}=820.1\text{MHz}$
 $f_{LO}=690\text{MHz}$, $P_{LO}=-10\text{dBm}$

$$\text{IIP3} = \frac{3\text{IF}-\text{IM3}}{2} - G_c$$
 @ $P_{RF}=-27\text{dBm}$

NJG1551F

TYPICAL CHARACTERISTICS (Continued)

Conversion Gain , Noise Figure vs. Temperature

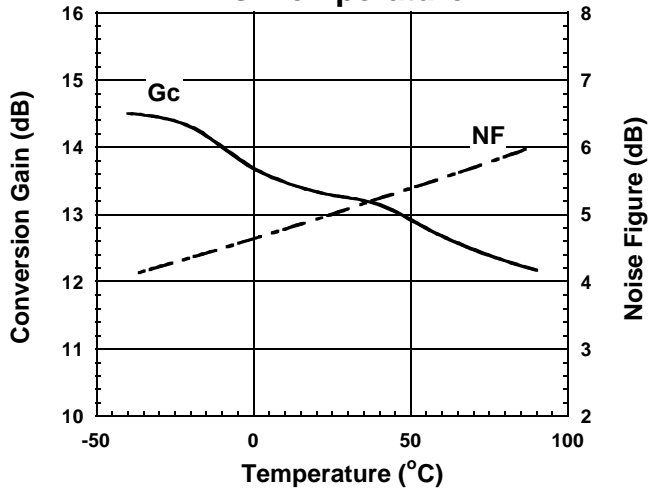

Condition
 $f_{IF}=130\text{MHz}$
 $f_{RF}=820\text{MHz}$, $P_{RF}=-30\text{dBm}$
 $f_{LO}=690\text{MHz}$, $P_{LO}=-10\text{dBm}$
 $V_{MIX}=V_{LO}=2.7\text{V}$

Input-IP3 vs. Temperature

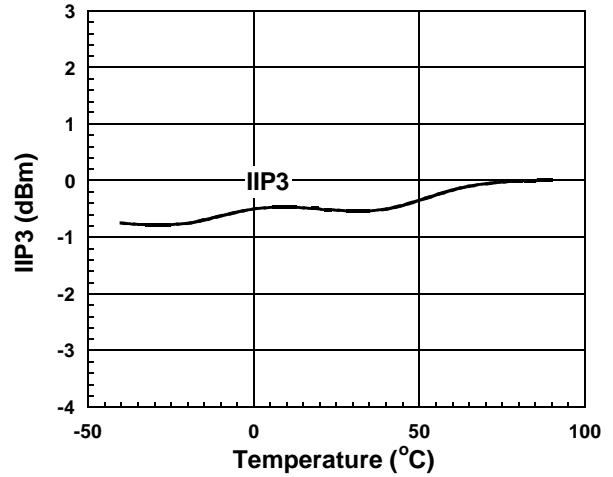

Condition
 $f_{IF}=130\text{MHz}$
 $f_{RF1}=820.0\text{MHz}$, $P_{RF}=-30\text{dBm}$
 $f_{RF2}=820.1\text{MHz}$
 $f_{LO}=690\text{MHz}$, $P_{LO}=-10\text{dBm}$
 $V_{MIX}=V_{LO}=2.7\text{V}$

$$IIP3 = \frac{3IF-IM3}{2} - G_c$$

@ $P_{RF}=-27\text{dBm}$

Conversion Gain vs. LO Power Temperature Response

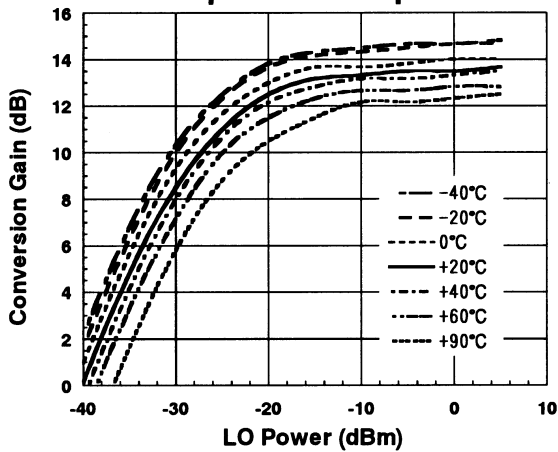

Condition
 $f_{IF}=130\text{MHz}$
 $f_{RF}=820\text{MHz}$, $P_{RF}=-30\text{dBm}$
 $f_{LO}=690\text{MHz}$
 $V_{MIX}=V_{LO}=2.7\text{V}$

Noise Figure vs. LO Power Temperature Response

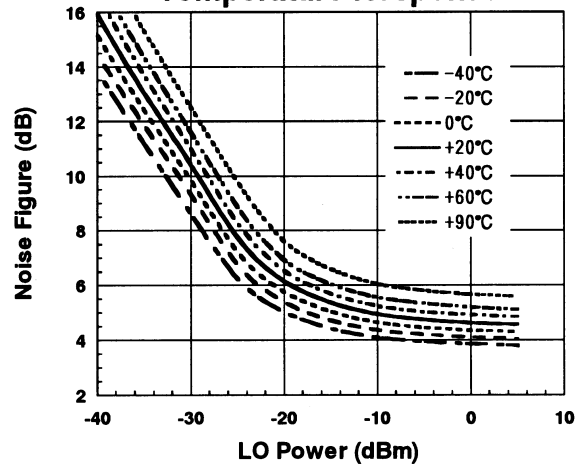

Condition
 $f_{IF}=130\text{MHz}$
 $f_{RF}=820\text{MHz}$
 $f_{LO}=690\text{MHz}$
 $V_{MIX}=V_{LO}=2.7\text{V}$

TYPICAL CHARACTERISTICS (Continued)

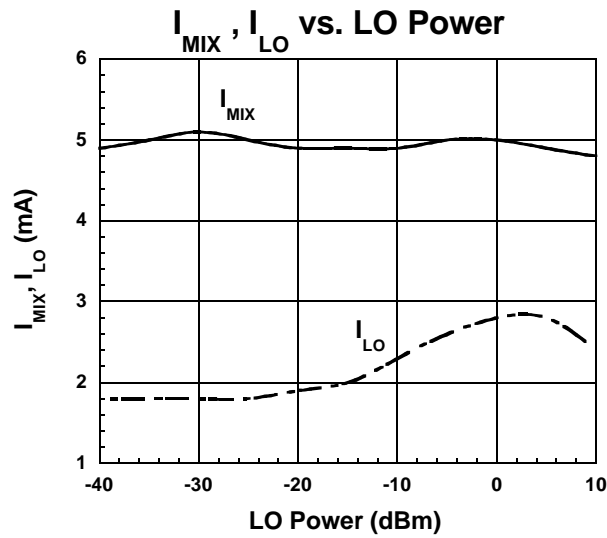

Condition
 $f_{RF}=820\text{MHz}$, $P_{RF}=-30\text{dBm}$
 $f_{LO}=690\text{MHz}$
 $V_{MIX}=V_{LO}=2.7\text{V}$

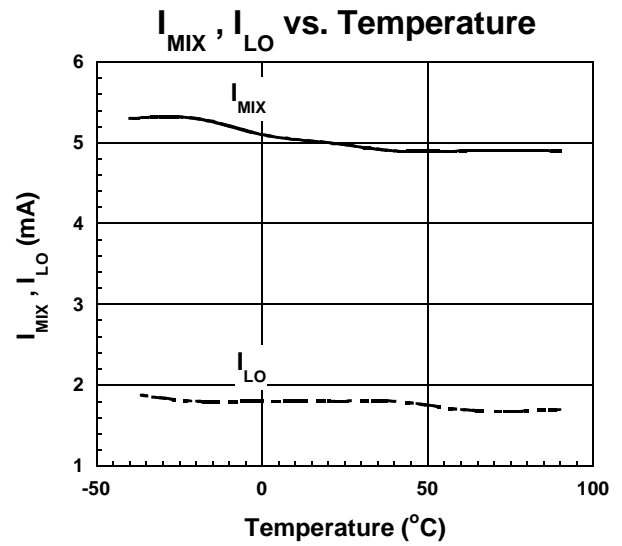

Condition
 $P_{RF}=\text{OFF}$
 $P_{LO}=\text{OFF}$
 $V_{MIX}=V_{LO}=2.7\text{V}$

TYPICAL CHARACTERISTICS (Application 1, $f_{LO}=720\text{MHz}$)

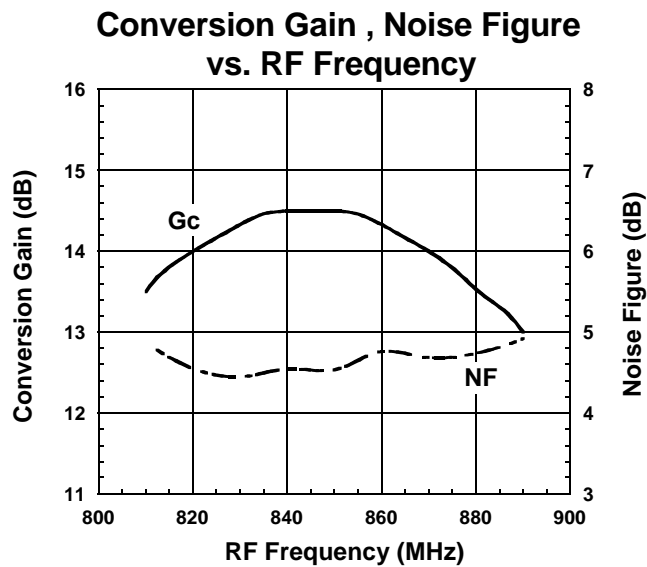

Condition
 $f_{IF}=130\text{MHz}$
 $P_{RF}=-30\text{dBm}$
 $P_{LO}=-10\text{dBm}$
 $V_{MIX}=V_{LO}=2.7\text{V}$
 Lower LOCAL

NJG1551F

■TYPICAL CHARACTERISTICS (Application 1, $f_{LO}=690\text{MHz}$)

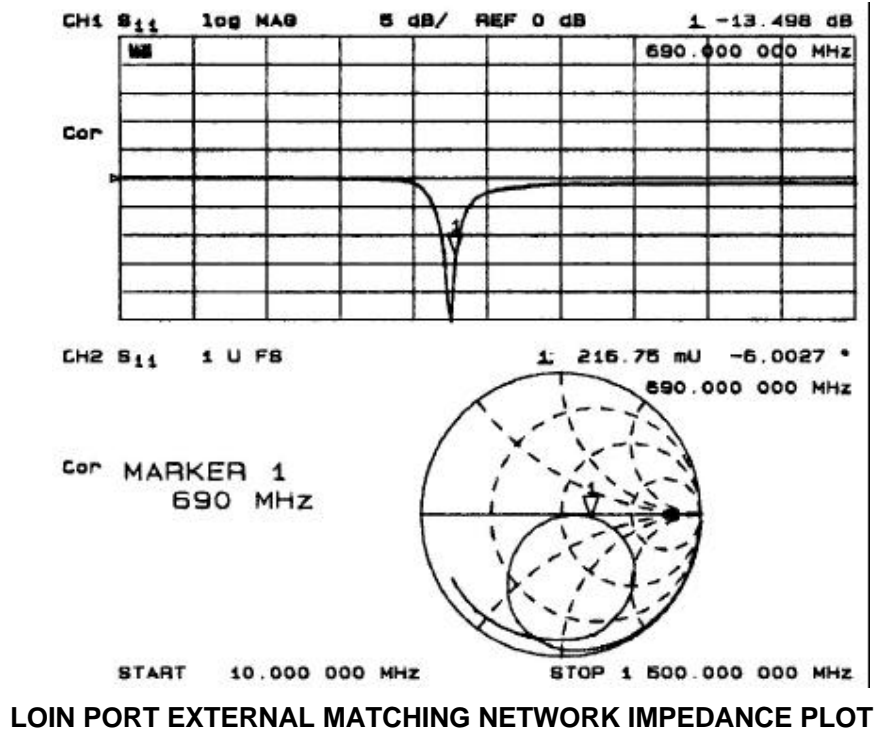
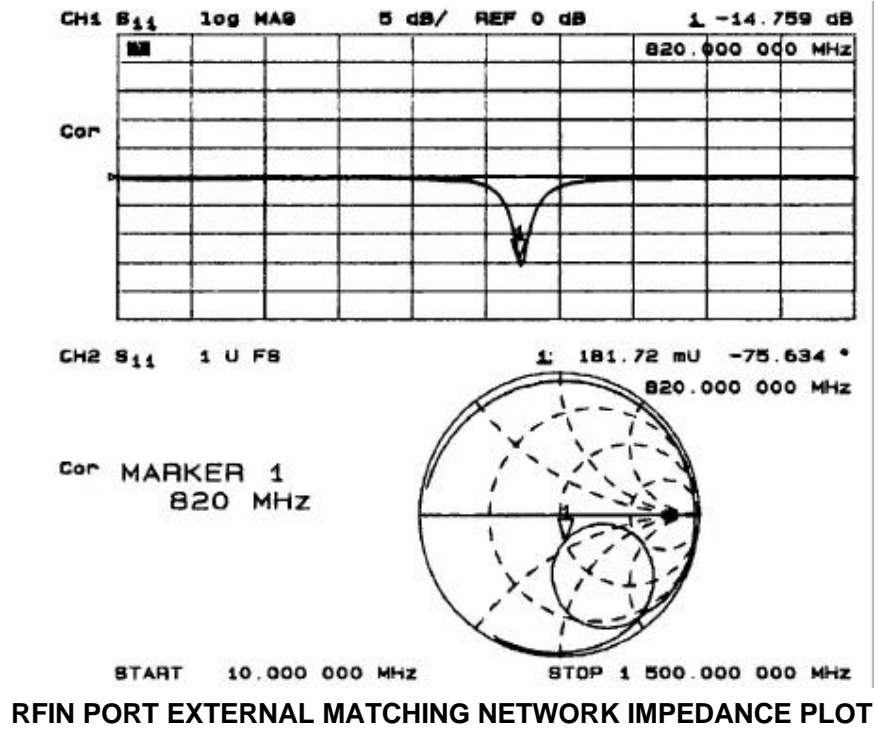

■TYPICAL CHARACTERISTICS (Continued)

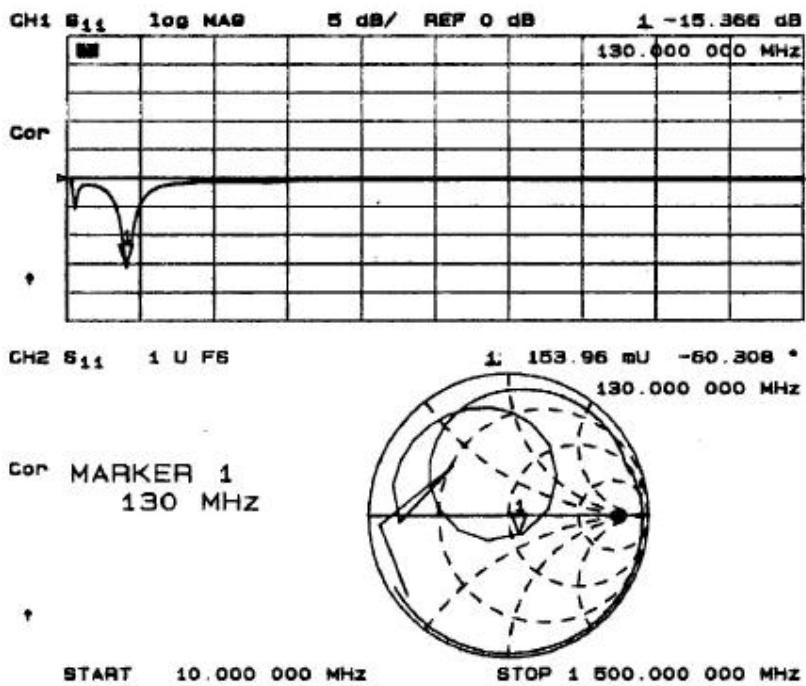

IFOUT PORT EXTERNAL MATCHING NETWORK IMPEDANCE PLOT

NJG1551F

■ TYPICAL CHARACTERISTICS (Application 2, $f_{LO}=796.12\text{MHz}$)

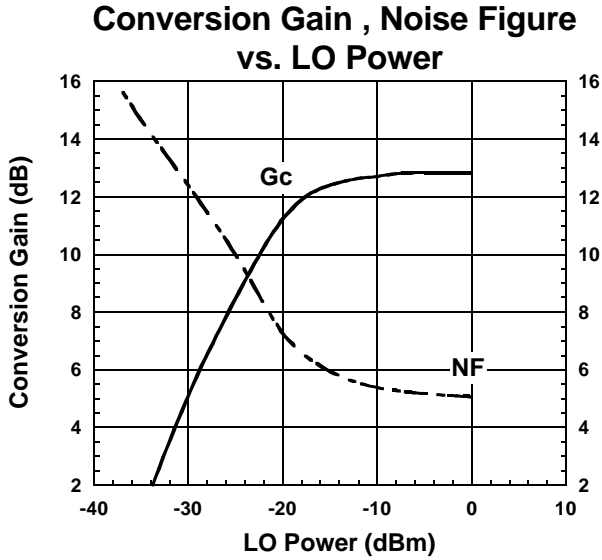

Condition
 $f_{IF}=85.38\text{MHz}$
 $f_{RF}=881.5\text{MHz}$, $P_{RF}=-30\text{dBm}$
 $f_{LO}=796.12\text{MHz}$
 $V_{MIX}=V_{LO}=2.7\text{V}$

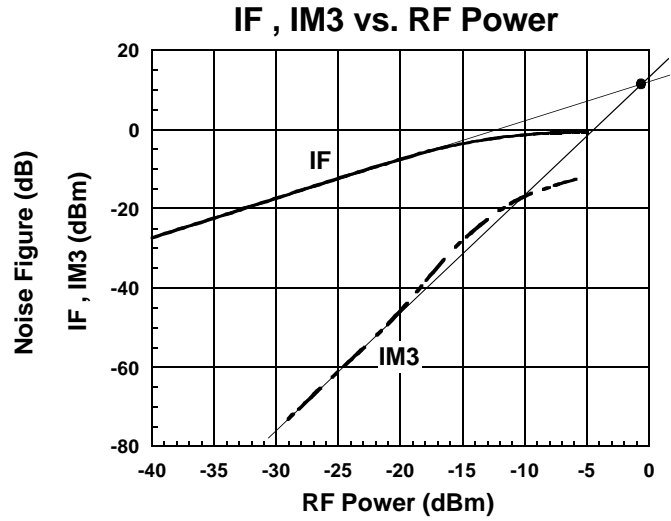

Condition
 $f_{IF}=85.38\text{MHz}$
 $f_{RF1}=881.5\text{MHz}$
 $f_{RF2}=881.6\text{MHz}$
 $f_{LO}=796.12\text{MHz}$, $P_{LO}=-10\text{dBm}$
 $V_{MIX}=V_{LO}=2.7\text{V}$

■ TYPICAL CHARACTERISTICS (Application 2, $f_{LO}=980\text{MHz}$)

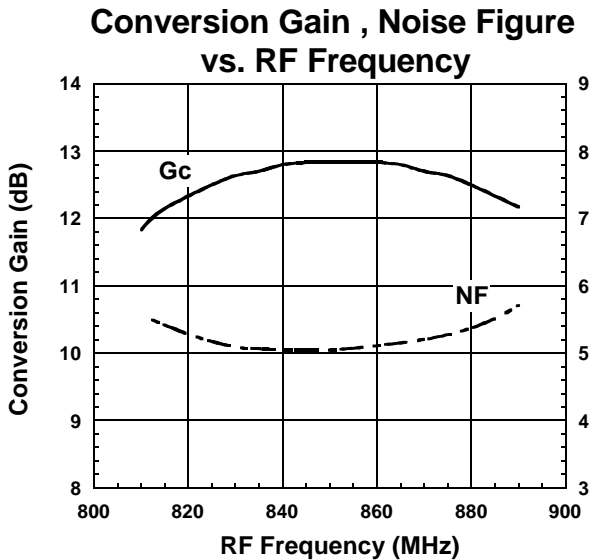

Condition
 $f_{IF}=130\text{MHz}$
 $P_{RF}=-30\text{dBm}$
 $P_{LO}=-10\text{dBm}$
 $V_{MIX}=V_{LO}=2.7\text{V}$
 Upper LOCAL

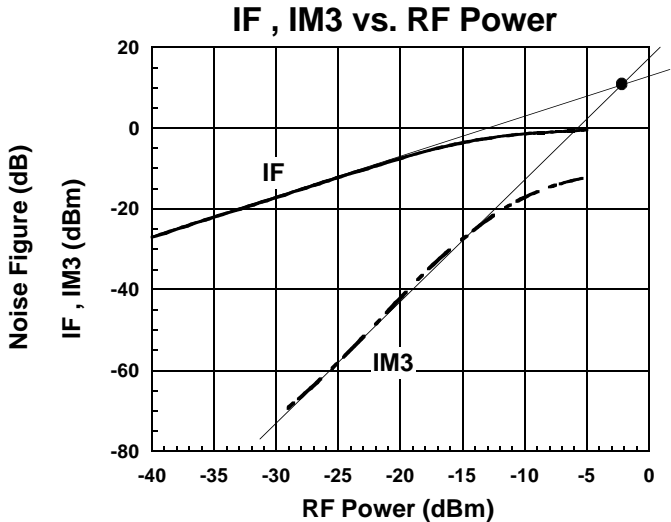

Condition
 $f_{IF}=130\text{MHz}$
 $f_{RF1}=850.0\text{MHz}$
 $f_{RF2}=850.1\text{MHz}$
 $f_{LO}=980\text{MHz}$, $P_{LO}=-10\text{dBm}$
 $V_{MIX}=V_{LO}=2.7\text{V}$

APPLICATION CIRCUIT 1 (Application 1)

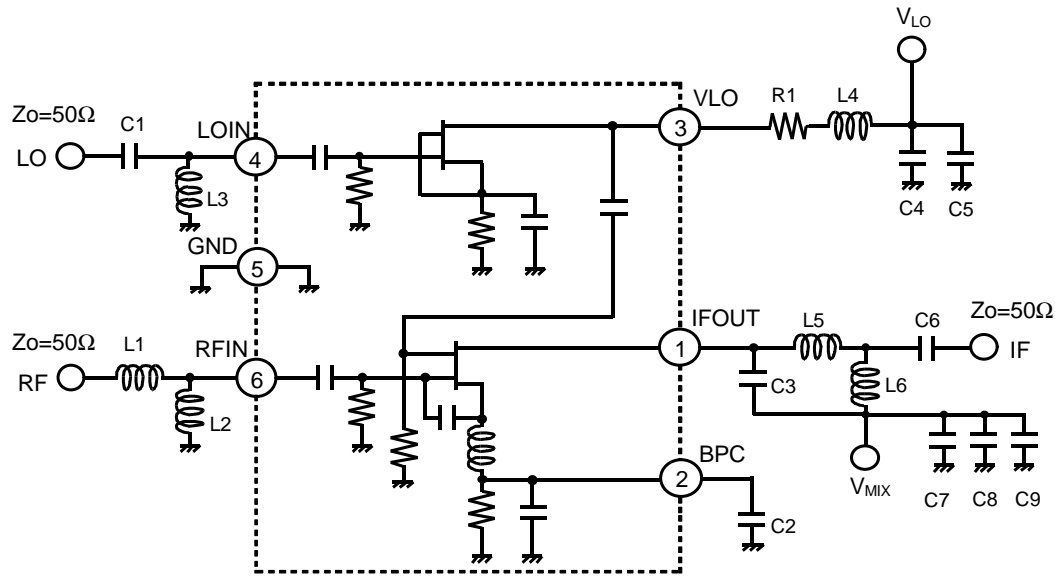

PARTS LIST

PART ID	800MHz BAND			COMMENT
	Lower LOCAL	Lower LOCAL		
	$f_{LO}=690\text{MHz}$ $f_{IF}=130\text{MHz}$	$f_{LO}=720\text{MHz}$ $f_{IF}=130\text{MHz}$		
L1	39nH	33nH		TAIYO-YUDEN (HK1608)
L2	27nH	27nH		TAIYO-YUDEN (HK1608)
L3	22nH	18nH		TAIYO-YUDEN (HK1608)
L4	33nH	33nH		TAIYO-YUDEN (HK1608)
L5	82nH	82nH		TAIYO-YUDEN (HK1608)
L6	56nH	56nH		TAIYO-YUDEN (HK1608)
C1	1pF	1pF		MURATA (GRM39)
C2	470pF	470pF		MURATA (GRM39)
C3	11pF	11pF		MURATA (GRM39)
C4	100pF	100pF		MURATA (GRM39)
C5	1000pF	1000pF		MURATA (GRM39)
C6	1000pF	1000pF		MURATA (GRM39)
C7	10pF	10pF		MURATA (GRM39)
C8	100pF	100pF		MURATA (GRM39)
C9	1000pF	1000pF		MURATA (GRM39)
R1	120Ω	120Ω		TAMA Electronics (CRG16G)

NJG1551F

APPLICATION CIRCUIT 2 (Application 2)

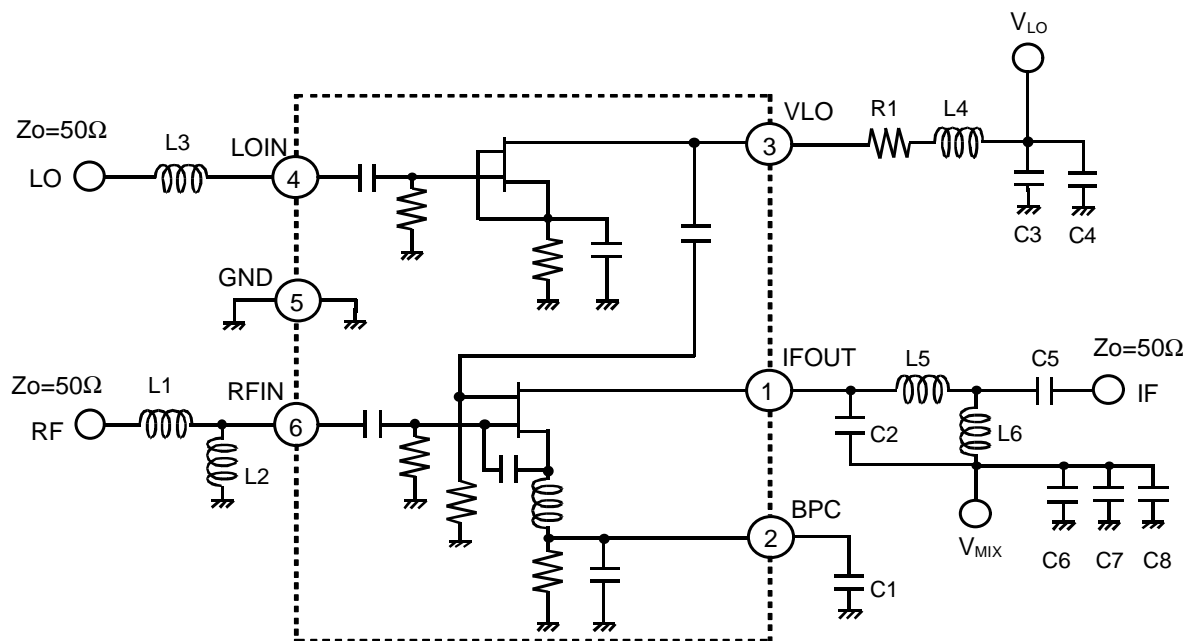

PARTS LIST

PART ID	800MHz BAND			COMMENT
	Lower LOCAL	Upper LOCAL		
	$f_{LO}=796.12\text{MHz}$ $f_{IF}=85.38\text{MHz}$	$f_{LO}=980\text{MHz}$ $f_{IF}=130\text{MHz}$		
L1	39nH	33nH		TAIYO-YUDEN (HK1608)
L2	22nH	27nH		TAIYO-YUDEN (HK1608)
L3	27nH	18nH		TAIYO-YUDEN (HK1608)
L4	27nH	22nH		TAIYO-YUDEN (HK1608)
L5	100nH	82nH		TAIYO-YUDEN (HK1608)
L6	47nH	56nH		TAIYO-YUDEN (HK1608)
C1	470pF	470pF		MURATA (GRM39)
C2	24pF	11pF		MURATA (GRM39)
C3	100pF	100pF		MURATA (GRM39)
C4	1000pF	1000pF		MURATA (GRM39)
C5	1000pF	1000pF		MURATA (GRM39)
C6	10pF	10pF		MURATA (GRM39)
C7	100pF	100pF		MURATA (GRM39)
C8	1000pF	1000pF		MURATA (GRM39)
R1	100Ω	100Ω		TAMA Electronics (CRG16G)

RECOMMENDED PCB DESIGN

(TOP VIEW)

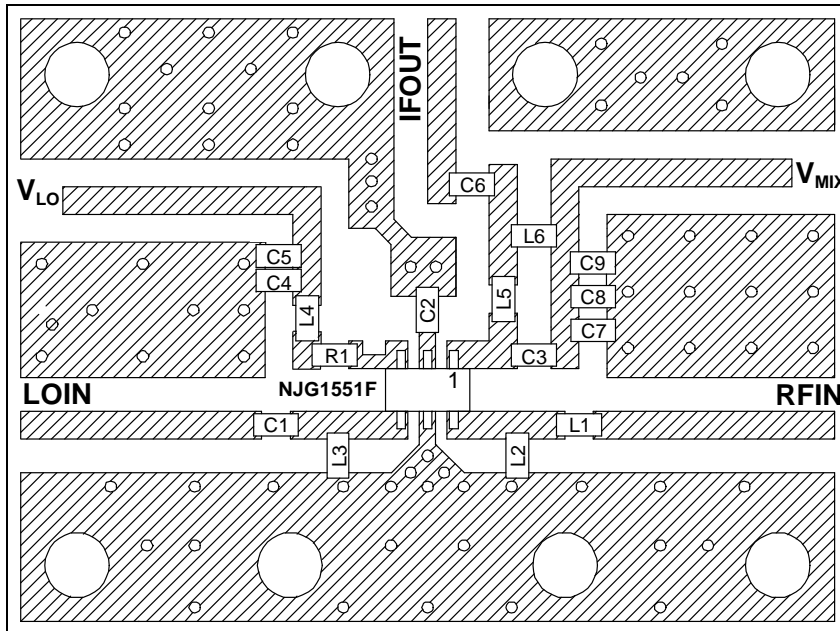

PCB: FR-4, $t=0.5\text{mm}$
 STRIPLINE WIDTH=1mm
 ($Z_0=50\Omega$)

(SIZE: 22.5mmx30mm)

PRECAUTIONS

- [1] Please locate L4 and R1 close to VLO terminal (3).
- [2] Distance from L1 and RFIN terminal (6) is 3.5mm.
- [3] Distance from C1 and LOIN terminal (4) is 3.5mm.
- [4] Please locate C2 close to BPC terminal (2).
- [5] Please locate C7, C8 and C9 close to C3, L6.
- [6] Please locate C4, C5 close to L4.

MEASURING BLOCK DIAGRAM

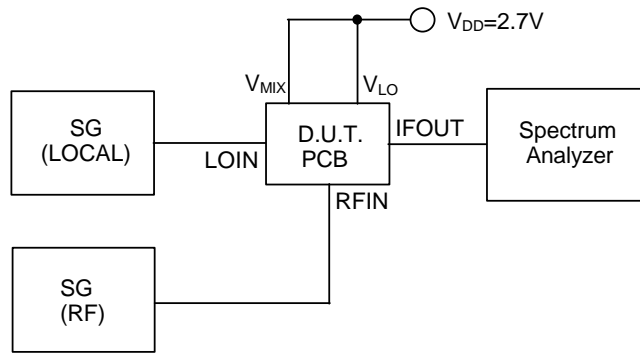

Conversion Gain Measurement Block Diagram

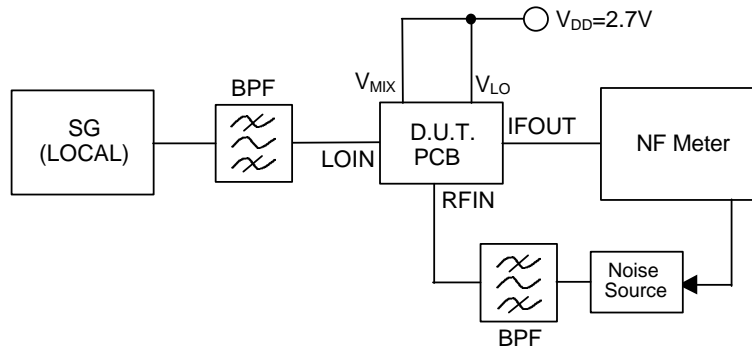

Noise Figure Measurement Block Diagram

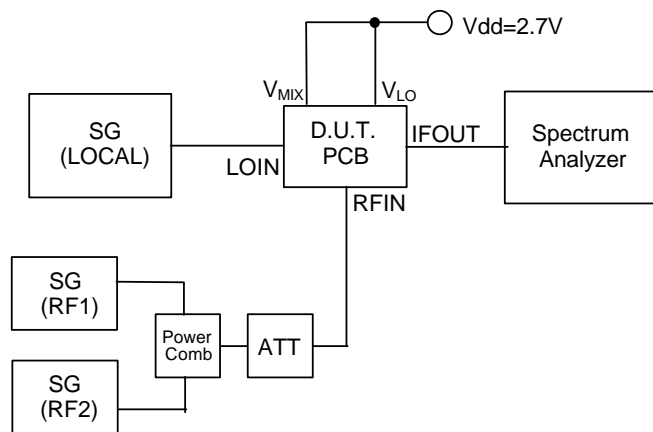

IF, IM3, IM5 Measurement Block Diagram

PACKAGE OUTLINE (MTP6)

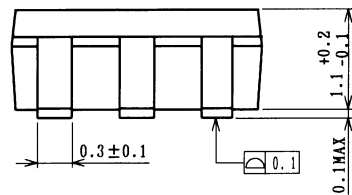
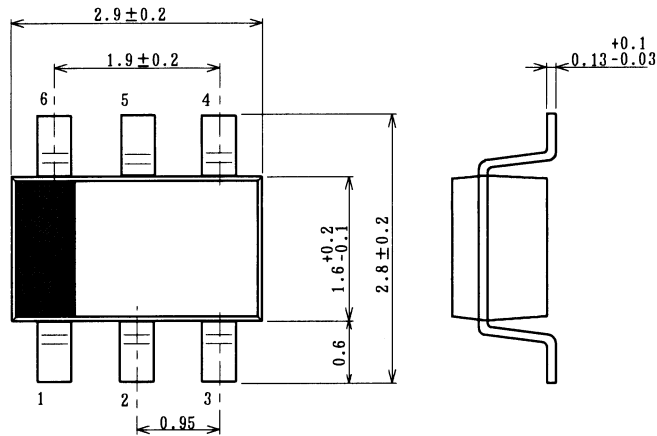

Lead material	: Copper
Lead surface finish	: Solder plating
Molding material	: Epoxy resin
UNIT	: mm
Weight	: 14mg

Cautions on using this product

This product contains Gallium-Arsenide (GaAs) which is a harmful material.

- Do NOT eat or put into mouth.
- Do NOT dispose in fire or break up this product.
- Do NOT chemically make gas or powder with this product.
- To waste this product, please obey the relating law of your country.

This product may be damaged with electric static discharge (ESD) or spike voltage. Please handle with care to avoid these damages.

[CAUTION]

The specifications on this databook are only given for information, without any guarantee as regards either mistakes or omissions. The application circuits in this databook are described only to show representative usages of the product and not intended for the guarantee or permission of any right including the industrial rights.