

## 800MHz BAND MIXER GaAs MMIC

### ■GENERAL DESCRIPTION

NJG1550F is a mixer GaAs MMIC featured low power consumption, high conversion gain and low noise figure.

NJG1550F includes a mixer and a local amplifier, and ideally suitable for 800MHz band digital mobile phone handsets.

A small MTP package is adopted.

### ■PACKAGE OUTLINE

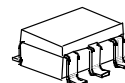

NJG1550F

### ■FEATURES

- Low voltage operation +2.7V
- Low current consumption 4.5mA typ.
- High conversion gain 14dB typ. @ $f_{RF}=820\text{MHz}$ ,  $P_{LO}=-10\text{dBm}$ ,  $P_{RF}=-30\text{dBm}$
- Low noise figure 5dB typ. @ $f_{RF}=820\text{MHz}$ ,  $P_{LO}=-10\text{dBm}$
- Package MTP6 (Mount Size: 2.8x2.9x1.2mm)

### ■PIN CONFIGURATION

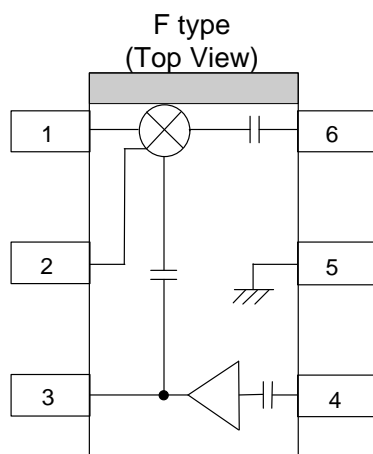

Pin connection

1. IFOUT
2. BPC
3. VLO
4. LOIN
5. GND
6. RFIN

NOTE :The portion above shows orientation mark printed on the package surface.

# NJG1550F

## ■ABSOLUTE MAXIMUM RATINGS

( $T_a=25^{\circ}\text{C}$ ,  $Z_s=Z_l=50\Omega$ )

PARAMETERS	SYMBOL	CONDITIONS	RATINGS	UNITS
Mixer Supply Voltage	$V_{\text{MIX}}$		5	V
Local Amplifier Supply Voltage	$V_{\text{DD}}$		5	V
Mixer RF Input Power	$P_{\text{RFIN}}$	$V_{\text{MIX}}=2.7\text{V}$ , $V_{\text{LO}}=2.7\text{V}$	10	dBm
Mixer LO Input Power	$P_{\text{LOIN}}$	$V_{\text{MIX}}=2.7\text{V}$ , $V_{\text{LO}}=2.7\text{V}$	10	dBm
Power Dissipation	$P_{\text{D}}$		150	mW
Operating Temp.	$T_{\text{opr}}$		-30~+85	$^{\circ}\text{C}$
Storage Tempe.	$T_{\text{stg}}$		-40~+150	$^{\circ}\text{C}$

## ■RECOMMENDED OPERATING RANGE

PARAMETER	SYMBOL	MIN	TYP	MAX	UNITS
Mixer Supply Voltage	$V_{\text{MIX}}$	2.5	2.7	4.5	V
Local Amplifier Supply Voltage	$V_{\text{LO}}$	2.5	2.7	4.5	V

## ■ELECTRICAL CHARACTERISTICS

( $T_a=25^{\circ}\text{C}$ ,  $V_{\text{MIX}}=2.7\text{V}$ ,  $V_{\text{LO}}=2.7\text{V}$ ,  $f_{\text{IF}}=130\text{MHz}$ ,  $P_{\text{LO}}=-10\text{dBm}$ )

PARAMETERS	SYMBOL	CONDITIONS	MIN	TYP	MAX	UNITS
Mixer Current	$I_{\text{MIX}}$	$P_{\text{RF}}=\text{OFF}$ , $P_{\text{LO}}=\text{OFF}$	-	3.0	4.5	mA
Local Amplifier Current	$I_{\text{LO}}$	$P_{\text{RF}}=\text{OFF}$ , $P_{\text{LO}}=\text{OFF}$	-	1.5	2.3	mA
Conversion Gain	$G_{\text{C}}$	$f_{\text{RF}}=820\text{MHz}$ , $P_{\text{RF}}=-30\text{dBm}$ $f_{\text{LO}}=690\text{MHz}$	11.0	14.0	-	dB
Input 3rd Order Intercept Point	IIP3	$f_{\text{RF}}=820.0\text{MHz}+820.1\text{MHz}$ $f_{\text{LO}}=690\text{MHz}$	-	-6.0	-	dBm
Noise Figure	NF	$f_{\text{RF}}=820\text{MHz}$ $f_{\text{LO}}=690\text{MHz}$	-	5.0	6.0	dB

## TYPICAL CHARACTERISTICS (Application 1, $f_{LO}=690\text{MHz}$ )

### Conversion Gain , Noise Figure vs. LO Power

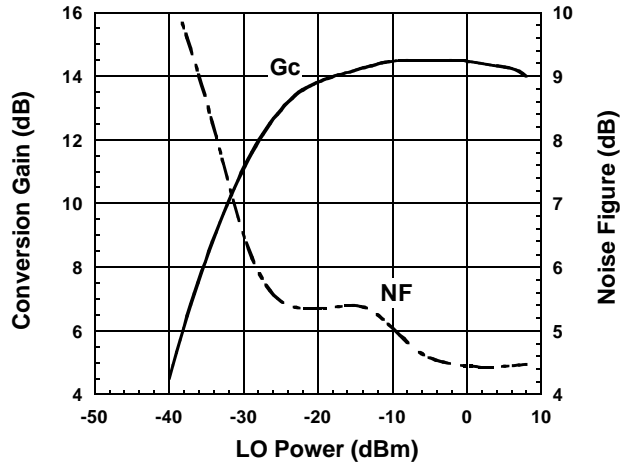

Condition  
 $f_{IF}=130\text{MHz}$   
 $f_{RF}=820\text{MHz}, P_{RF}=-30\text{dBm}$   
 $f_{LO}=690\text{MHz}$   
 $V_{MIX}=V_{LO}=2.7\text{V}$

### IF , IM3 , IM5 vs. RF Power

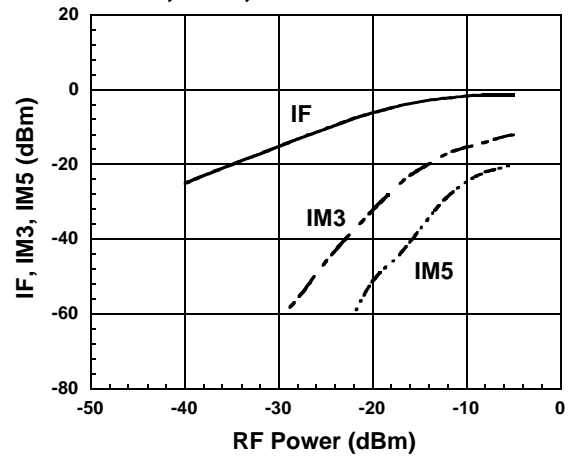

Condition  
 $f_{IF}=130\text{MHz}$   
 $f_{RF1}=820.0\text{MHz}$   
 $f_{RF2}=820.1\text{MHz}$   
 $f_{LO}=690\text{MHz}, P_{LO}=-10\text{dBm}$   
 $V_{MIX}=V_{LO}=2.7\text{V}$

### Input-IP3 vs. LO Power

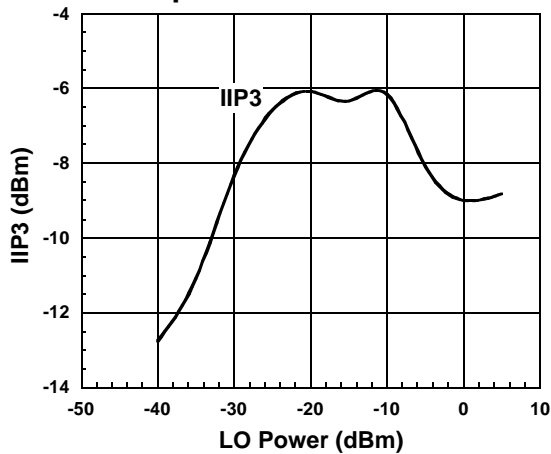

Condition  
 $f_{IF}=130\text{MHz}$   
 $f_{RF1}=820.0\text{MHz}, P_{RF}=-30\text{dBm}$   
 $f_{RF2}=820.1\text{MHz}$   
 $f_{LO}=690\text{MHz}$   
 $V_{MIX}=V_{LO}=2.7\text{V}$   

$$IIP3 = \frac{3IF-IM3}{2} - G_c$$
 @  $P_{RF} = -30\text{dBm}$

### Conversion Gain , Noise Figure , Input-IP3 vs. $V_{MIX}, V_{LO}$

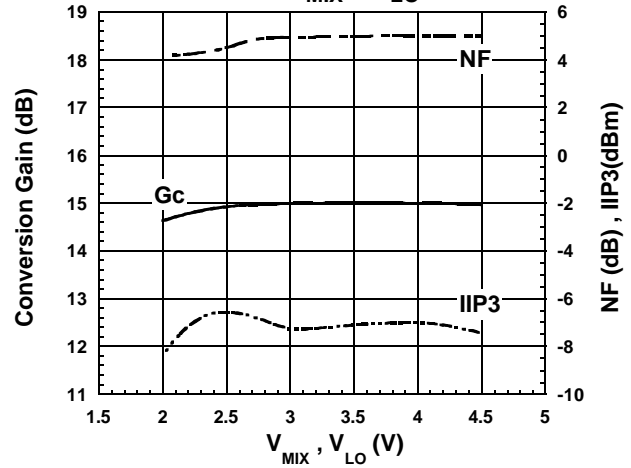

Condition  
 $f_{IF}=130\text{MHz}$   
 $f_{RF1}=820.0\text{MHz}, P_{RF}=-30\text{dBm}$   
 $f_{RF2}=820.1\text{MHz}$   
 $f_{LO}=690\text{MHz}, P_{LO}=-10\text{dBm}$   

$$IIP3 = \frac{3IF-IM3}{2} - G_c$$
 @  $P_{RF} = -30\text{dBm}$

## TYPICAL CHARACTERISTICS (Continued)

### Conversion Gain , Noise Figure vs. Temperature

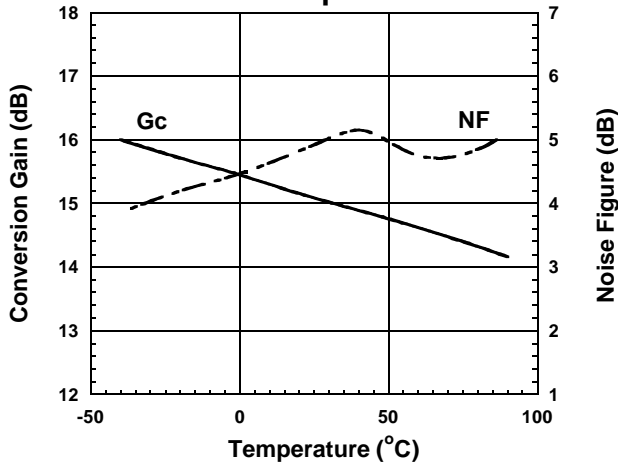

Condition  
 $f_{IF}=130\text{MHz}$   
 $f_{RF}=820\text{MHz}, P_{RF}=-30\text{dBm}$   
 $f_{LO}=690\text{MHz}, P_{LO}=-10\text{dBm}$   
 $V_{MIX}=V_{LO}=2.7\text{V}$

### Input-IP3 vs. Temperature

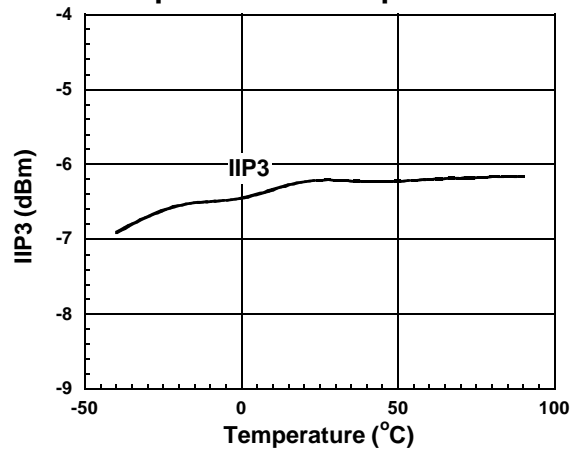

Condition  
 $f_{IF}=130\text{MHz}$   
 $f_{RF1}=820.0\text{MHz}, P_{RF}=-30\text{dBm}$   
 $f_{RF2}=820.1\text{MHz}$   
 $f_{LO}=690\text{MHz}, P_{LO}=-10\text{dBm}$   
 $V_{MIX}=V_{LO}=2.7\text{V}$

$$IIP3 = \frac{3IF-IM3}{2} - G_c$$

@  $P_{RF}=-30\text{dBm}$

### Conversion Gain vs. LO Power Temperature Response

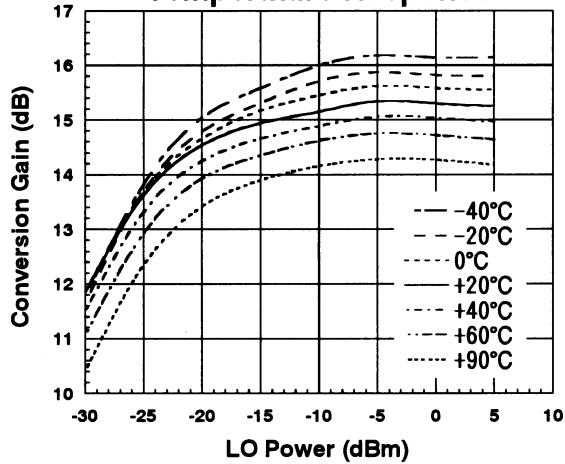

Condition  
 $f_{IF}=130\text{MHz}$   
 $f_{RF}=820\text{MHz}, P_{RF}=-30\text{dBm}$   
 $f_{LO}=690\text{MHz}$   
 $V_{MIX}=V_{LO}=2.7\text{V}$

### Noise Figure vs. LO Power Temperature Response

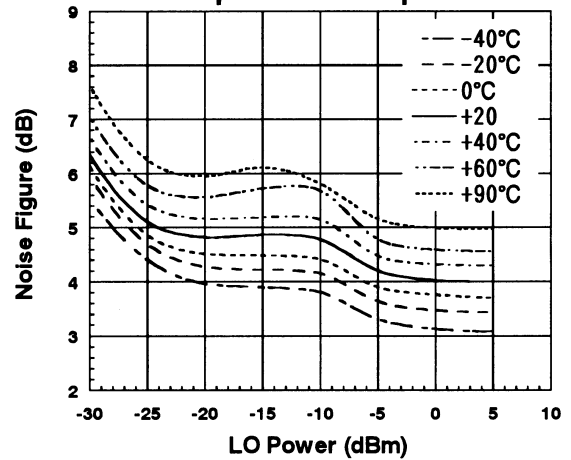

Condition  
 $f_{IF}=130\text{MHz}$   
 $f_{RF}=820\text{MHz}$   
 $f_{LO}=690\text{MHz}$   
 $V_{MIX}=V_{LO}=2.7\text{V}$

## ■ TYPICAL CHARACTERISTICS (Continued)

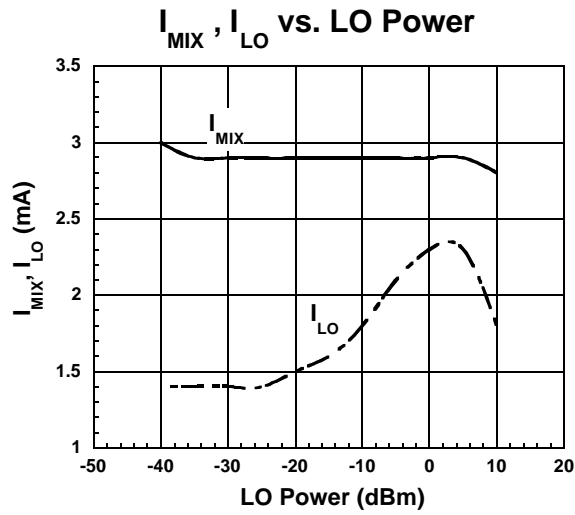

Condition  
 $f_{RF}=820\text{MHz}$   
 $P_{RF}=-30\text{dBm}$   
 $f_{LO}=690\text{MHz}$   
 $V_{MIX}=V_{LO}=2.7\text{V}$

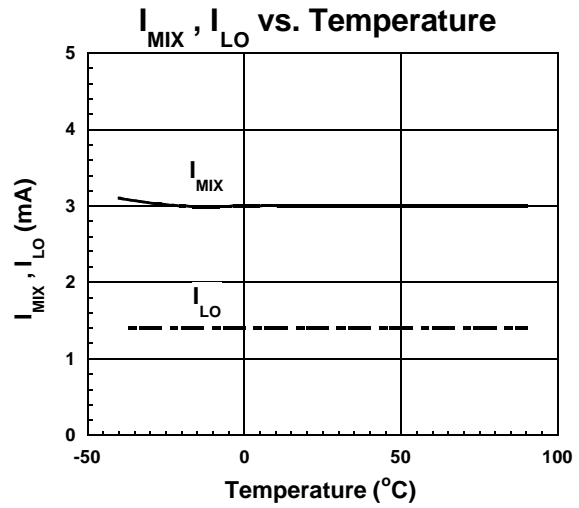

Condition  
 $P_{RF}=\text{OFF}$   
 $P_{LO}=\text{OFF}$   
 $V_{MIX}=V_{LO}=2.7\text{V}$

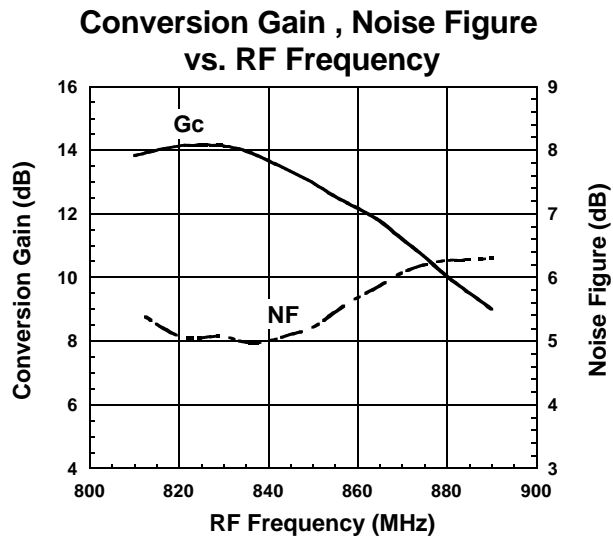

Condition  
 $f_{IF}=130\text{MHz}$   
 $P_{RF}=-30\text{dBm}$   
 $P_{LO}=-10\text{dBm}$   
 $V_{MIX}=V_{LO}=2.7\text{V}$   
 Lower LOCAL

# NJG1550F

## ■TYPICAL CHARACTERISTICS (Continued)

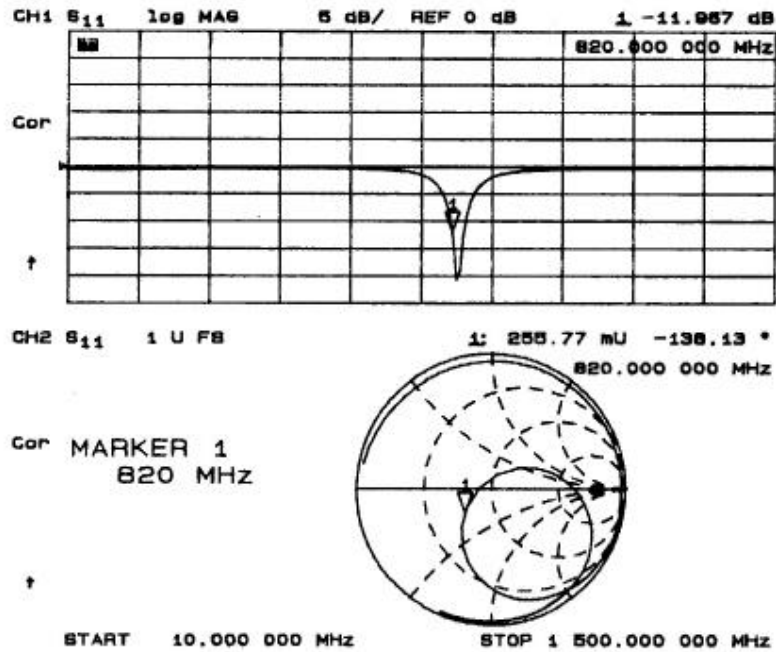

RFIN PORT EXTERNAL MATCHING NETWORK IMPEDANCE PLOT

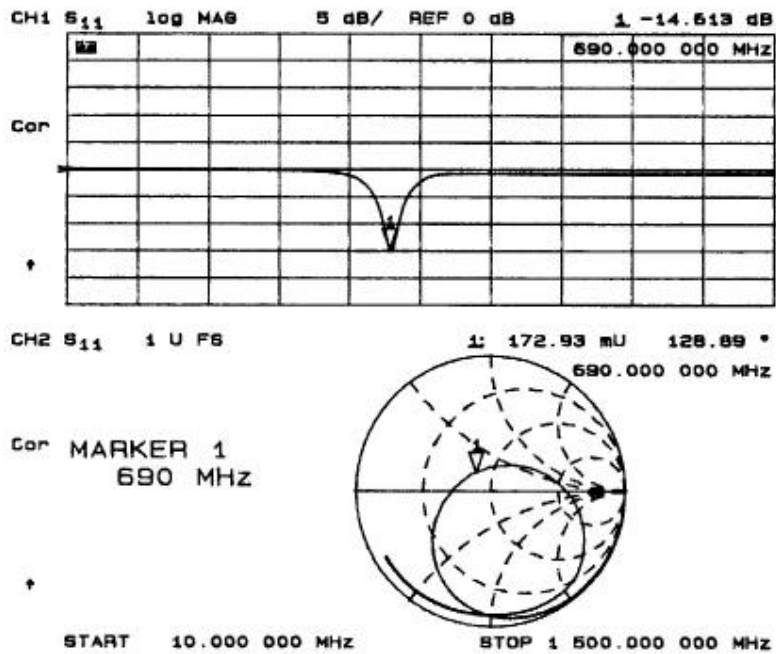

LOIN PORT EXTERNAL MATCHING NETWORK IMPEDANCE PLOT

## ■TYPICAL CHARACTERISTICS (Continued)

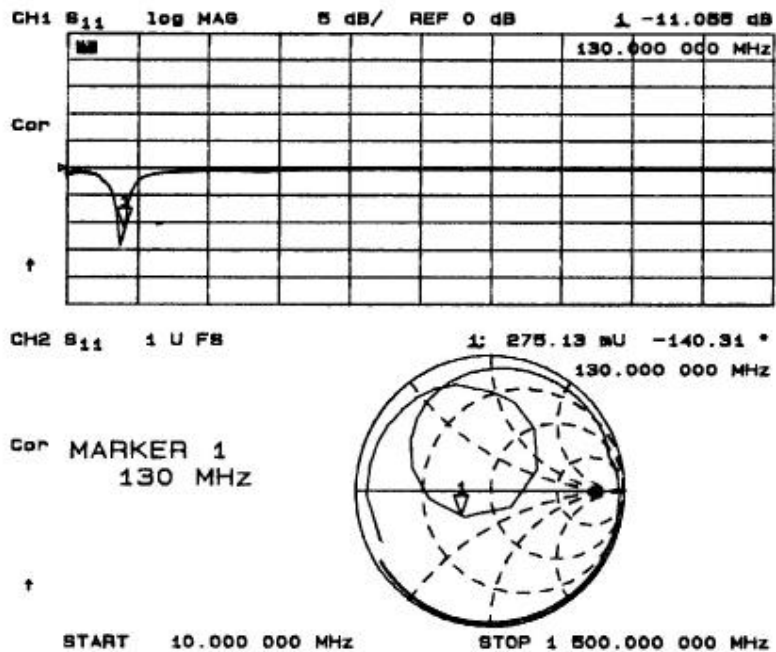

IFOUT PORT EXTERNAL MATCHING NETWORK IMPEDANCE PLOT

## ■ TYPICAL CHARACTERISTICS (Application 1, $f_{LO}=950\text{MHz}$ )

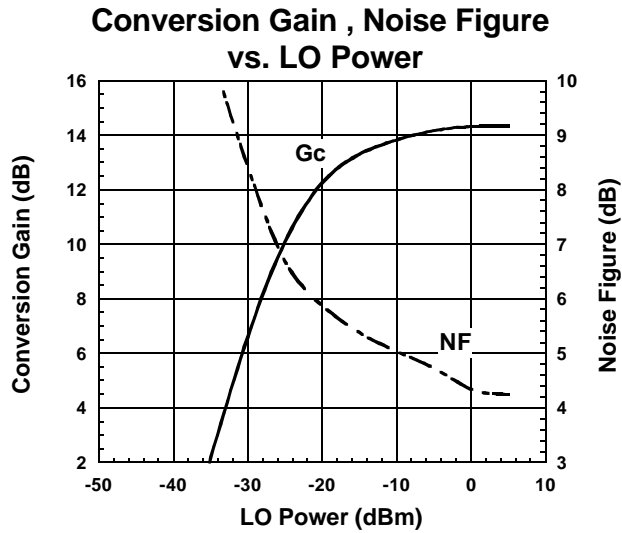

Condition  
 $f_{IF}=130\text{MHz}$   
 $f_{RF}=820\text{MHz}, P_{RF}=-30\text{dBm}$   
 $f_{LO}=950\text{MHz}$   
 $V_{MIX}=V_{LO}=2.7\text{V}$

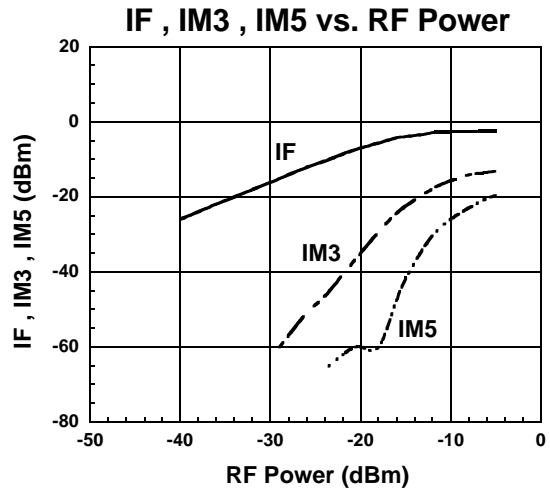

Condition  
 $f_{IF}=130\text{MHz}$   
 $f_{RF1}=820.0\text{MHz}$   
 $f_{RF2}=820.1\text{MHz}$   
 $f_{LO}=950\text{MHz}, P_{LO}=-10\text{dBm}$   
 $V_{MIX}=V_{LO}=2.7\text{V}$

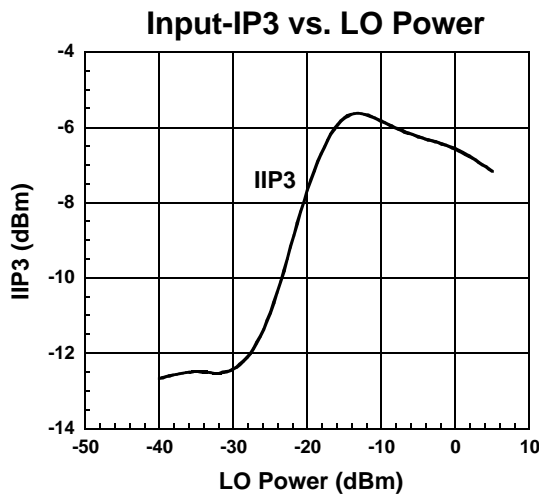

Condition  
 $f_{IF}=130\text{MHz}$   
 $f_{RF1}=820.0\text{MHz}, P_{RF}=-30\text{dBm}$   
 $f_{RF2}=820.1\text{MHz}$   
 $f_{LO}=950\text{MHz}$   
 $V_{MIX}=V_{LO}=2.7\text{V}$   

$$IIP3 = \frac{3IF - IM3}{2} - G_c$$
 @  $P_{RF}=-30\text{dBm}$

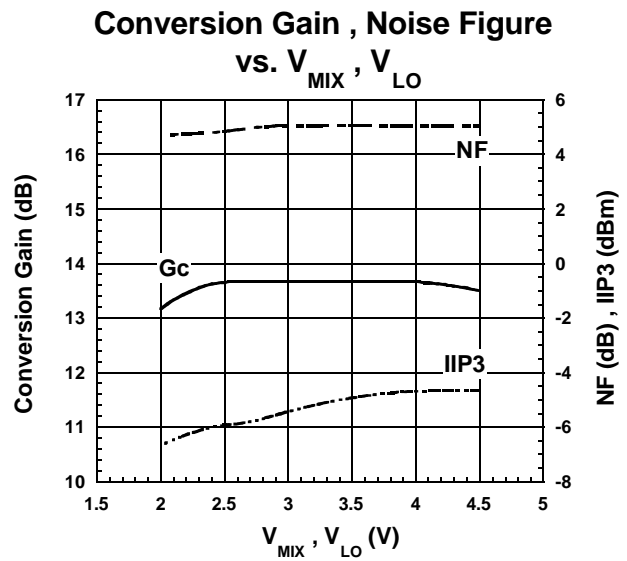

Condition  
 $f_{IF}=130\text{MHz}$   
 $f_{RF1}=820.0\text{MHz}, P_{RF}=-30\text{dBm}$   
 $f_{RF2}=820.1\text{MHz}$   
 $f_{LO}=950\text{MHz}, P_{LO}=-10\text{dBm}$   

$$IIP3 = \frac{3IF - IM3}{2} - G_c$$
 @  $P_{RF}=-30\text{dBm}$



## ■ TYPICAL CHARACTERISTICS (Application 1, $f_{LO}=964.66\text{MHz}$ )

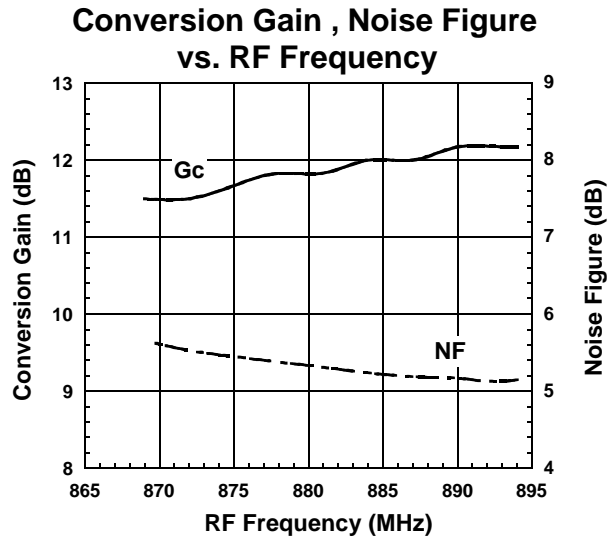

Condition  
 $f_{IF}=83.16\text{MHz}$   
 $P_{LO}=-10\text{dBm}$   
 $P_{RF}=-30\text{dBm}$   
 $V_{MIX}=V_{LO}=2.7\text{V}$   
 Upper LOCAL

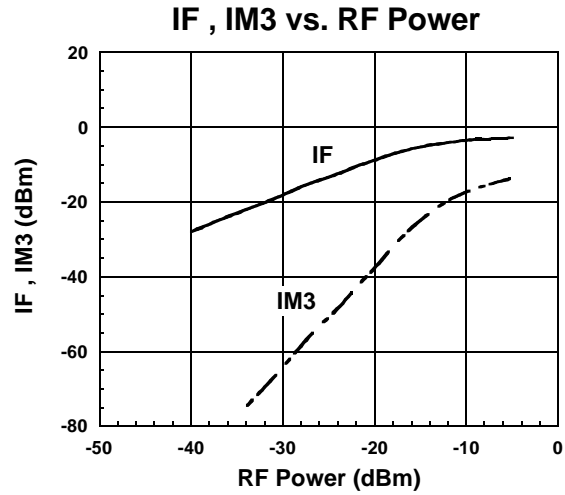

Condition  
 $f_{IF}=83.16\text{MHz}$   
 $f_{RF1}=881.5\text{MHz}$   
 $f_{RF2}=881.6\text{MHz}$   
 $f_{LO}=964.66\text{MHz}, P_{LO}=-10\text{dBm}$   
 $V_{MIX}=V_{LO}=2.7\text{V}$

## ■ TYPICAL CHARACTERISTICS (Application 1, $f_{LO}=926.5\text{MHz}$ )

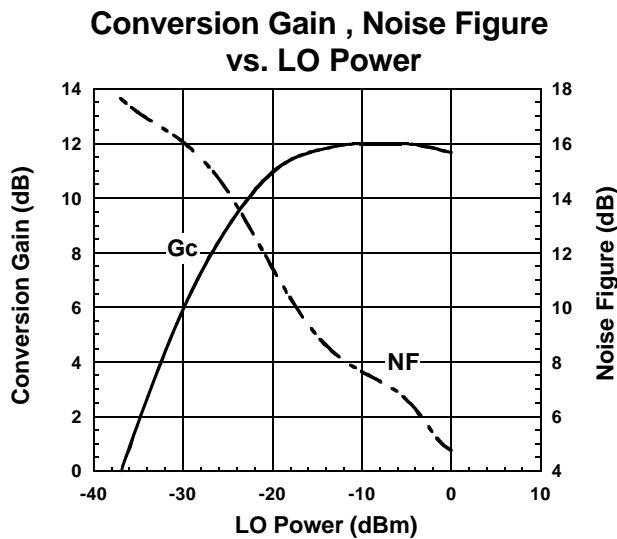

Condition  
 $f_{IF}=45\text{MHz}$   
 $f_{RF}=881.5\text{MHz}, P_{RF}=-30\text{dBm}$   
 $f_{LO}=926.5\text{MHz}$   
 $V_{MIX}=V_{LO}=2.7\text{V}$

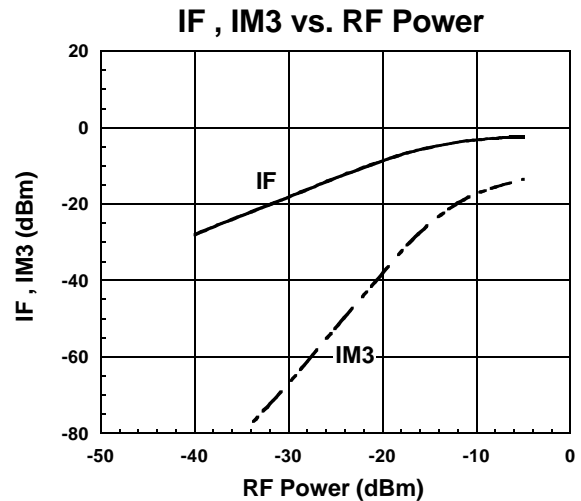

Condition  
 $f_{IF}=45\text{MHz}$   
 $f_{RF1}=881.5\text{MHz}$   
 $f_{RF2}=881.6\text{MHz}$   
 $f_{LO}=926.5\text{MHz}, P_{LO}=-10\text{dBm}$   
 $V_{MIX}=V_{LO}=2.7\text{V}$

# NJG1550F

## ■ TYPICAL CHARACTERISTICS (Application 2, $f_{LO}=796.12\text{MHz}$ )

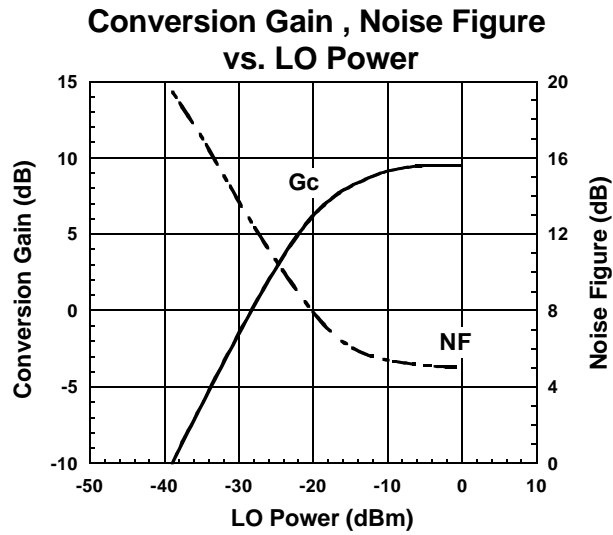

Condition  
 $f_{IF}=85.38\text{MHz}$   
 $f_{RF}=881.5\text{MHz}$ ,  $P_{RF}=-30\text{dBm}$   
 $f_{LO}=796.12\text{MHz}$   
 $V_{MIX}=V_{LO}=2.7\text{V}$

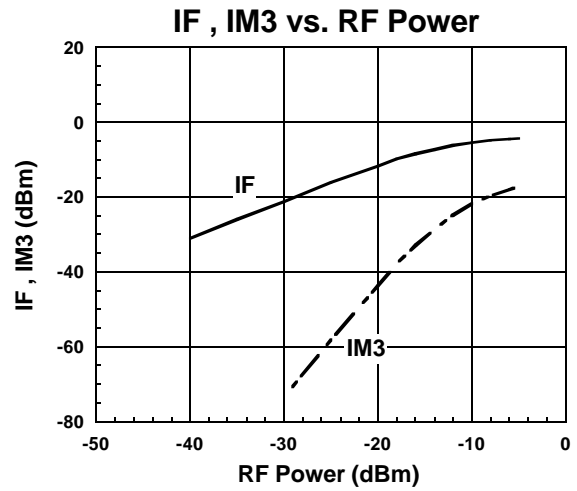

Condition  
 $f_{IF}=85.38\text{MHz}$   
 $f_{RF1}=881.5\text{MHz}$   
 $f_{RF2}=881.6\text{MHz}$   
 $f_{LO}=796.12\text{MHz}$ ,  $P_{LO}=-10\text{dBm}$   
 $V_{MIX}=V_{LO}=2.7\text{V}$

## APPLICATION CIRCUIT 1 (Application 1)

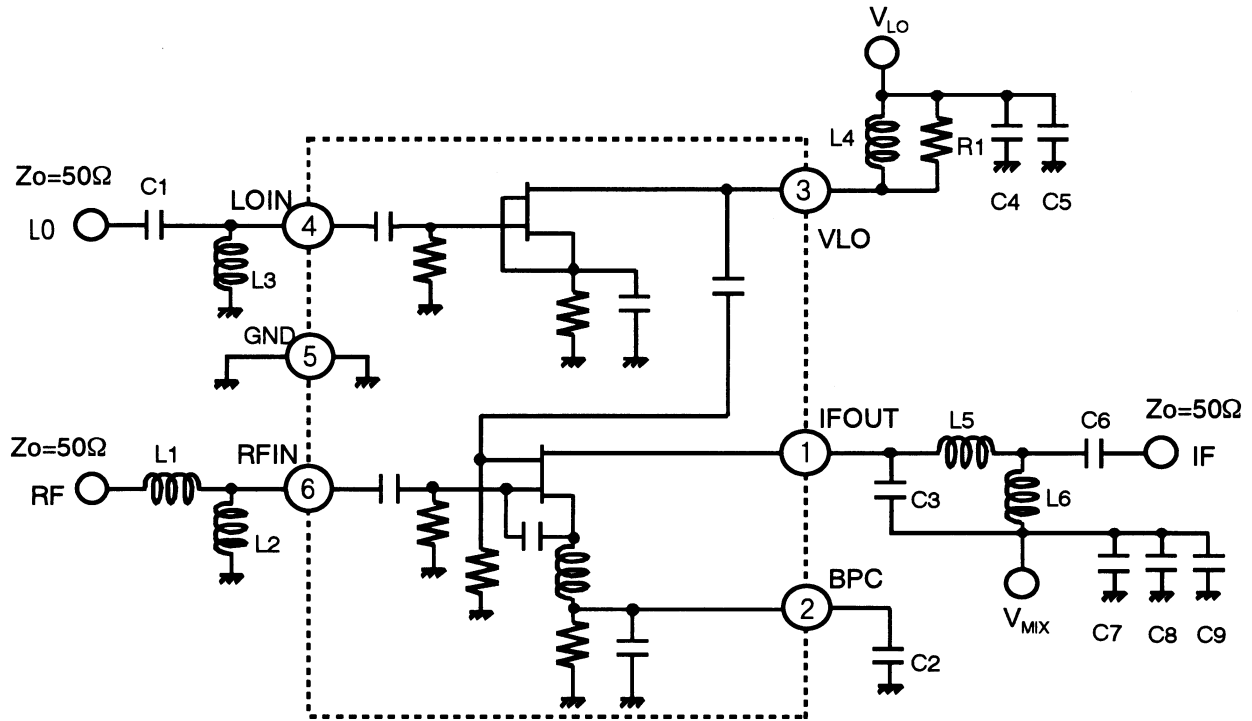

### PARTS LIST 1

PART ID	800MHz Band				COMMENT
	Lower LOCAL	Upper LOCAL	Upper LOCAL	Upper LOCAL	
	$f_{LO}=690\text{MHz}$ $f_{IF}=130\text{MHz}$	$f_{LO}=950\text{MHz}$ $f_{IF}=130\text{MHz}$	$f_{LO}=964.66\text{MHz}$ $f_{IF}=83.16\text{MHz}$	$f_{LO}=926.5\text{MHz}$ $f_{IF}=45\text{MHz}$	
L1	39nH	39nH	33nH	39nH	TAIYO-YUDEN(HK1608)
L2	27nH	27nH	22nH	22nH	TAIYO-YUDEN(HK1608)
L3	22nH	15nH	12nH	15nH	TAIYO-YUDEN(HK1608)
L4	27nH	22nH	22nH	18nH	TAIYO-YUDEN(HK1608)
L5	100nH	100nH	100nH	150nH	TAIYO-YUDEN(HK1608)
L6	56nH	56nH	47nH	120nH	TAIYO-YUDEN(HK1608)
C1	1pF	0.5pF	0.5pF	0.5pF	MURATA(GRM39)
C2	470pF	470pF	470pF	470pF	MURATA(GRM39)
C3	11pF	11pF	24pF	39pF	MURATA(GRM39)
C4	100pF	100pF	100pF	100pF	MURATA(GRM39)
C5	1000pF	1000pF	1000pF	1000pF	MURATA(GRM39)
C6	1000pF	1000pF	1000pF	47pF	MURATA(GRM39)
C7	10pF	10pF	10pF	10pF	MURATA(GRM39)
C8	100pF	100pF	100pF	100pF	MURATA(GRM39)
C9	1000pF	1000pF	0.1uF	1000pF	MURATA(GRM39)
R1	560Ω	360Ω	360Ω	470Ω	TAMA Electronics(CRG16G)

# NJG1550F

## APPLICATION CIRCUIT 2 (Application 2)

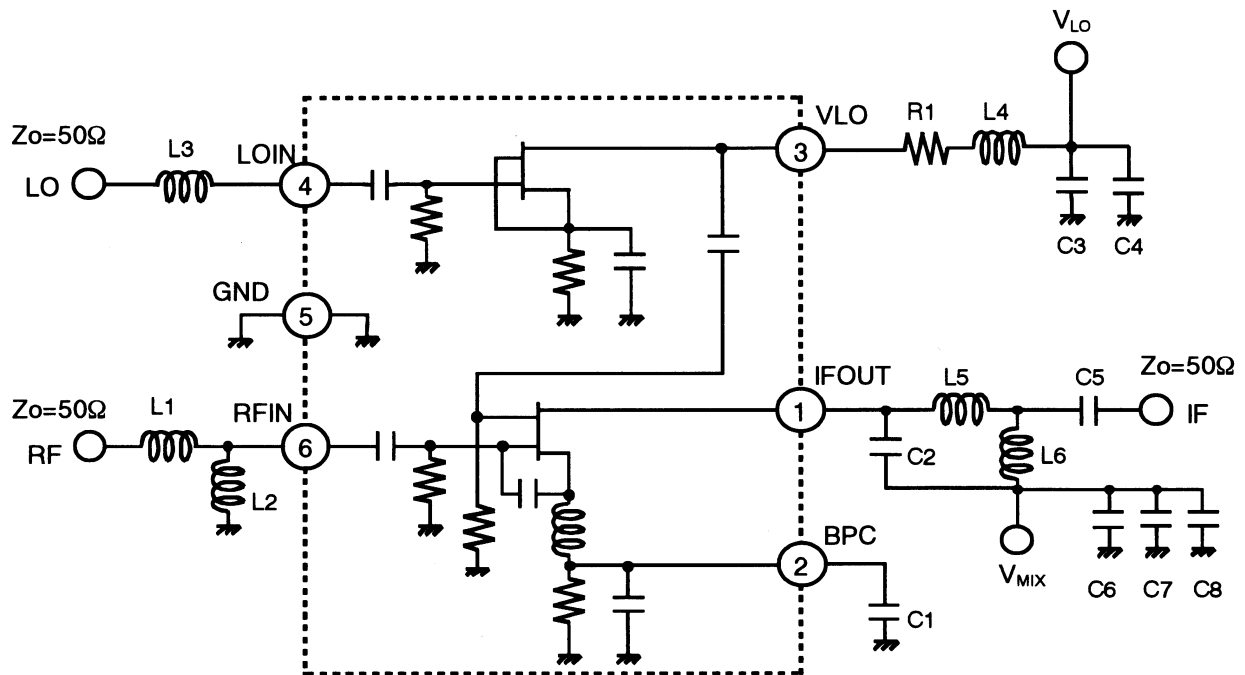

### PARTS LIST 2

PART ID	800MHz Band		COMMENT
	Lower LOCAL		
	$f_{LO}=796.12\text{MHz}$		
	$f_{IF}=85.38\text{MHz}$		
L1	33nH		TAIYO-YUDEN(HK1608)
L2	22nH		TAIYO-YUDEN(HK1608)
L3	27nH		TAIYO-YUDEN(HK1608)
L4	27nH		TAIYO-YUDEN(HK1608)
L5	100nH		TAIYO-YUDEN(HK1608)
L6	47nH		TAIYO-YUDEN(HK1608)
C1	470pF		MURATA(GRM39)
C2	24pF		MURATA(GRM39)
C3	100pF		MURATA(GRM39)
C4	1000pF		MURATA(GRM39)
C5	1000pF		MURATA(GRM39)
C6	10pF		MURATA(GRM39)
C7	100pF		MURATA(GRM39)
C8	1000pF		MURATA(GRM39)
R1	100Ω		TAMA Electronics(CRG16G)

## RECOMMENDED PCB DESIGN

(TOP VIEW)

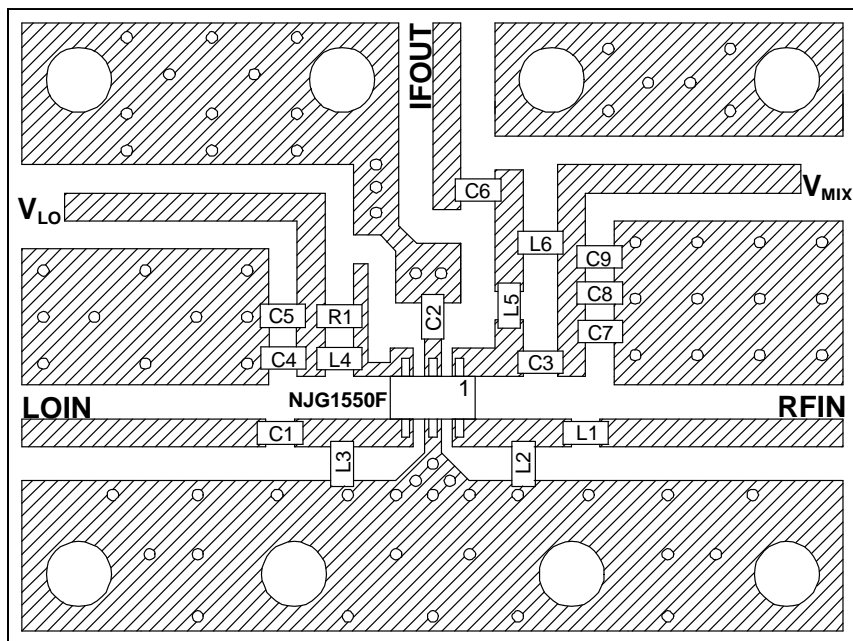

PCB: FR-4, t=0.5mm  
 STRIPLINE WIDTH=1mm  
 ( $Z_0=50\Omega$ )

(SIZE: 22.5mm x 30mm)

## PRECAUTIONS

- [1] Please locate L4 and R1 close to V<sub>LO</sub> terminal (3).
- [2] Distance from L1 and RFIN terminal (6) is 3.5mm.
- [3] Distance from C1 and LOIN terminal (4) is 3.5mm.
- [4] Please locate C2 close to BPC terminal (2).
- [5] Please locate C7, C8, C9 close to C3, L6.
- [6] Please locate C4, C5 close to R1, L4.

## MEASURING BLOCK DIAGRAM

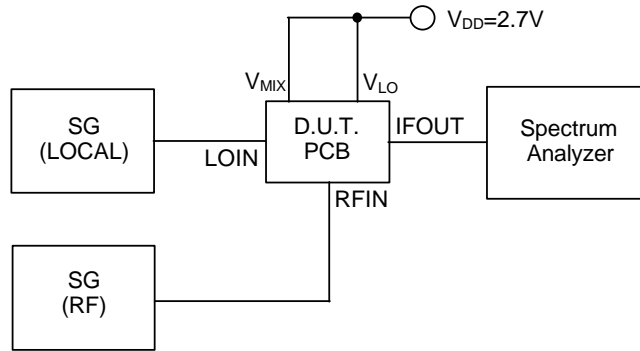

Conversion Gain Measurement Block Diagram

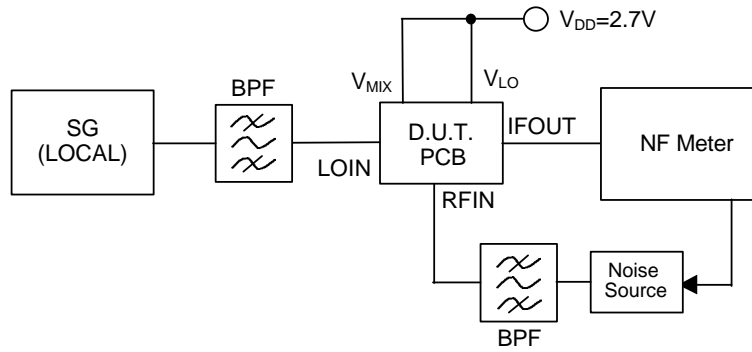

Noise Figure Measurement Block Diagram

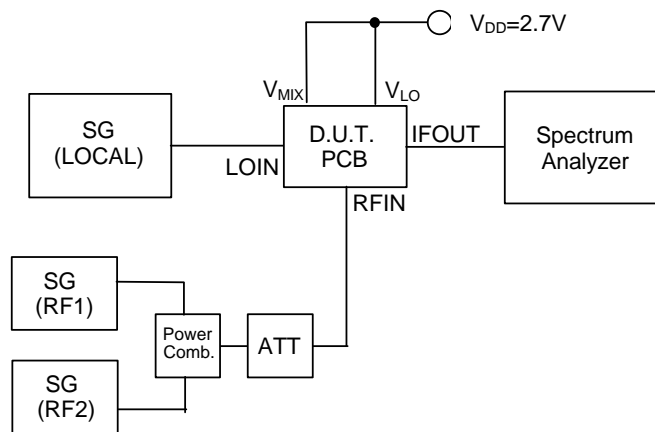

IF, IM3, IM5 Measurement Block Diagram

## PACKAGE OUTLINE (MTP6)

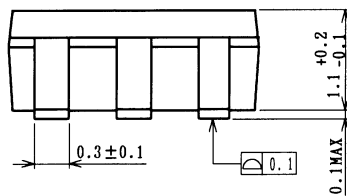
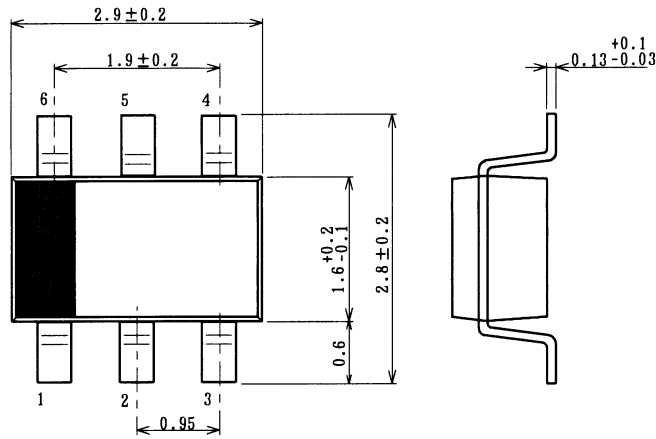

Lead material	: Copper
Lead surface finish	: Solder plating
Molding material	: Epoxy resin
UNIT	: mm
Weight	: 14mg

### Cautions on using this product

This product contains Gallium-Arsenide (GaAs) which is a harmful material.

- Do NOT eat or put into mouth.
- Do NOT dispose in fire or break up this product.
- Do NOT chemically make gas or powder with this product.
- To waste this product, please obey the relating law of your country.

### [CAUTION]

The specifications on this databook are only given for information, without any guarantee as regards either mistakes or omissions. The application circuits in this databook are described only to show representative usages of the product and not intended for the guarantee or permission of any right including the industrial rights.

This product may be damaged with electric static discharge (ESD) or spike voltage. Please handle with care to avoid these damages.