

BIPOLAR DIGITAL INTEGRATED CIRCUIT

μ PB1510GV

3 GHz INPUT DIVIDE BY 4 PRESCALER IC FOR DBS TUNERS

The μ PB1510GV is a 3.0 GHz input divide by 4 prescaler IC for DBS tuner applications. The μ PB1510GV is suitable for use of frequency divider for PLL synthesizer block. The μ PB1510GV is a shrink package version of the μ PB585G so that this small package contributes to reduce the mounting space.

The μ PB1510GV is manufactured using NEC's high fr NESAT™ IV silicon bipolar process. This process uses silicon nitride passivation film and gold electrodes. These materials can protect chip surface from external pollution and prevent corrosion/migration. Thus, this IC has excellent performance, uniformity and reliability.

FEATURES

- High toggle frequency : $f_{in} = 0.5 \text{ GHz to } 3.0 \text{ GHz}$
- High-density surface mounting : 8-pin plastic SSOP (175 mil)
- Low current consumption : 5 V, 14 mA TYP.
- Fixed division : +4

APPLICATION

- Prescaler between local oscillator and PLL frequency synthesizer included modulus prescaler
- DBS tuners with kit use of VHF/UHF band PLL frequency synthesizer

ORDERING INFORMATION

Part Number	Package	Marking	Supplying Form
μ PB1510GV-E1	8-pin plastic SSOP (175 mil)	1510	Embossed tape 8 mm wide. Pin 1 is in tape pull-out direction. 1000 p/reel

Remark To order evaluation samples, please contact your local NEC sales office.
(Part number for sample order: μ PB1510GV)

Caution Electro-static sensitive devices

The information in this document is subject to change without notice.

PIN CONNECTION (Top View)

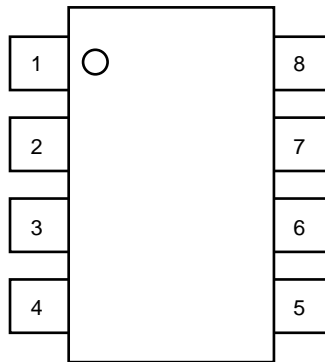

Pin No.	Pin name
1	V _{cc}
2	IN
3	$\overline{\text{IN}}$
4	GND
5	GND
6	NC
7	OUT
8	NC

PRODUCT LINE-UP

Features (Division, Frequency)	Part number	I _{cc} (mA)	f _{in} (GHz)	V _{cc} (V)	Package	Pin Connection
$\div 4$, 2.5 GHz input	μ PB585G	18	0.5 to 2.5	4.5 to 5.5	8-pin SOP (225 mil)	NEC Original
$\div 4$, 3.0 GHz input	μ PB1510GV	14	0.5 to 3.0	4.5 to 5.5	8-pin SSOP (175 mil)	

Remark This table shows the TYP values of main parameters. Please refer to ELECTRICAL CHARACTERISTICS.

μ PB585G is discontinued.

★ INTERNAL BLOCK DIAGRAM

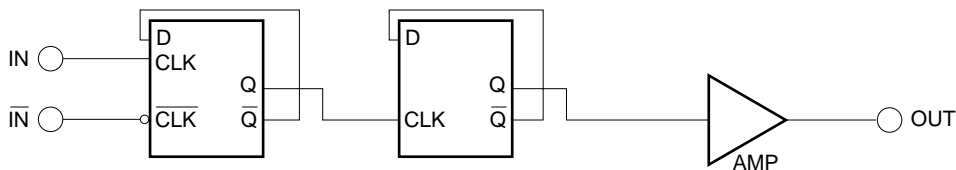

SYSTEM APPLICATION EXAMPLE

RF unit block of DBS tuners

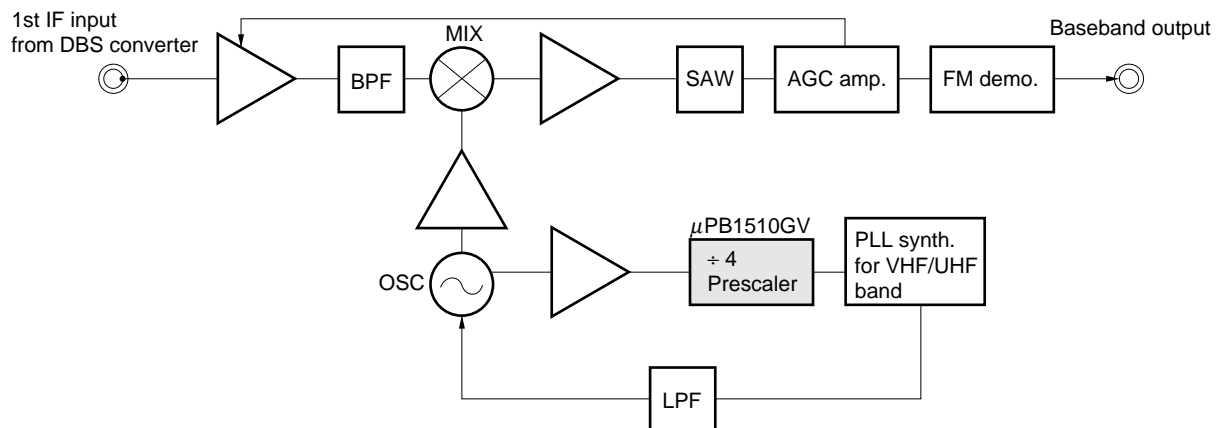

PIN EXPLANATION

Pin No.	Symbol	Applied Voltage (Unit: V)	Pin Voltage (Unit: V)	Functions and Explanation
1	V _{CC}	4.5 to 5.5	—	Supply voltage pin. This pin must be equipped with bypass capacitor (e.g. 1 000 pF) to minimize ground impedance.
2	IN	—	1.7 to 4.95	Signal input pin. This pin should be coupled to signal source with capacitor (e.g. 1 000 pF) for DC cut.
3	$\overline{\text{IN}}$	—	1.7 to 4.95	Signal input bypass pin. This pin must be equipped with bypass capacitor (e.g. 1 000 pF) to minimize ground impedance.
4, 5	GND	0	—	Ground pin. Ground pattern on the board should be formed as wide as possible to minimize ground impedance.
6, 8	NC	—	—	Non connection pins. These pins should be opened.
7	OUT	—	1.0 to 4.7	Divided frequency output pin. This pin is designed as emitter follower output. This pin can be connected to input of prescaler within PLL synthesizer through DC cut capacitor.

★ ABSOLUTE MAXIMUM RATINGS

Parameter	Symbol	Conditions	Ratings	Unit
Supply voltage	V _{CC}	T _A = +25 °C	6.0	V
Total power dissipation	P _D	Mounted on double sided copper clad 50 × 50 × 1.6 mm epoxy glass PWB (T _A = +85 °C)	250	mW
Operating ambient temperature	T _A		-40 to +85	°C
Storage temperature	T _{stg}		-55 to +150	°C

RECOMMENDED OPERATING CONDITIONS

Parameter	Symbol	MIN.	TYP.	MAX.	Unit	Notice
Supply voltage	V _{CC}	4.5	5.0	5.5	V	
Operating ambient temperature	T _A	-40	+25	+85	°C	

ELECTRICAL CHARACTERISTICS (T_A = -40 to +85 °C, V_{CC} = 4.5 to 5.5 V, Z_s = Z_L = 50 Ω)

Parameter	Symbol	Test Conditions	MIN.	TYP.	MAX.	Unit
Circuit current	I _{CC}	No signals	10.5	14	17	mA
Upper limit operating frequency 1	f _{in(U)1}	P _{in} = -10 to +6 dBm	3.0	—	—	GHz
Upper limit operating frequency 2	f _{in(U)2}	P _{in} = -15 to +6 dBm	2.7	—	—	GHz
Lower limit operating frequency	f _{in(L)}	P _{in} = -15 to +6 dBm	—	—	0.5	GHz
Input power 1	P _{in1}	f _{in} = 2.7 to 3.0 GHz	-10	—	+6	dBm
Input power 2	P _{in2}	f _{in} = 0.5 to 2.7 GHz	-15	—	+6	dBm
Output power	P _{out}	P _{in} = 0 dBm, f _{in} = 2.0 GHz	-12	-7	—	dBm

★ TYPICAL CHARACTERISTICS ($T_A = 25^\circ\text{C}$, $V_{CC} = 5\text{ V}$, unless otherwise specified)

CIRCUIT CURRENT vs. SUPPLY VOLTAGE

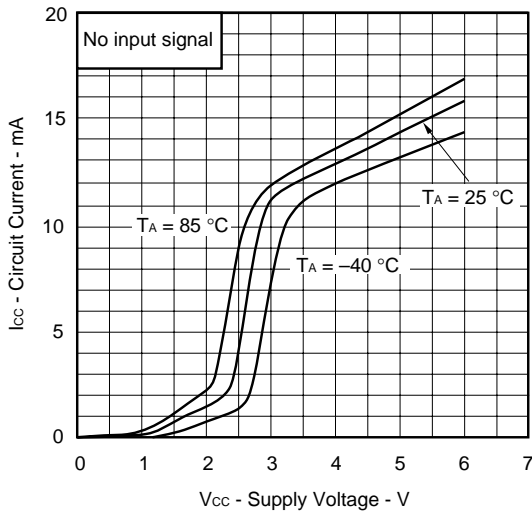

INPUT POWER vs. INPUT FREQUENCY

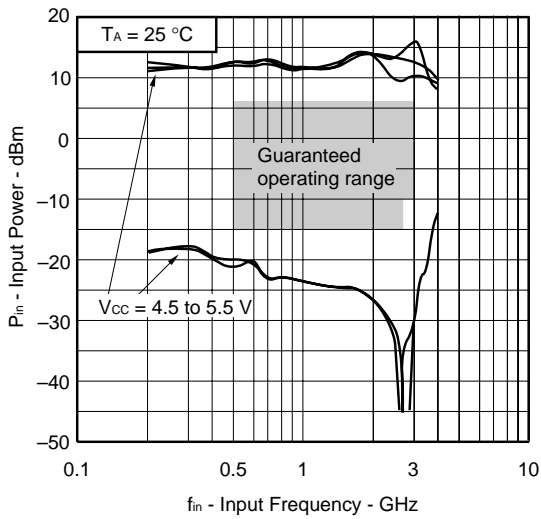

INPUT POWER vs. INPUT FREQUENCY

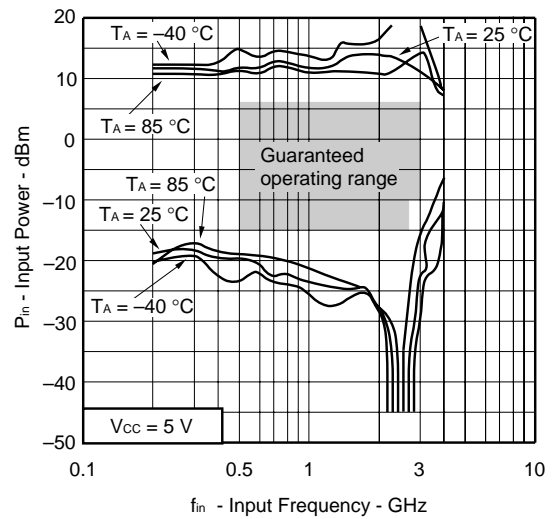

OUTPUT POWER vs. INPUT FREQUENCY

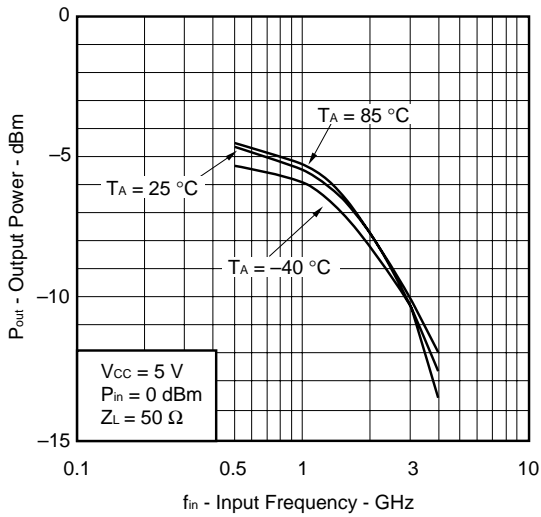

OUTPUT POWER vs. INPUT FREQUENCY

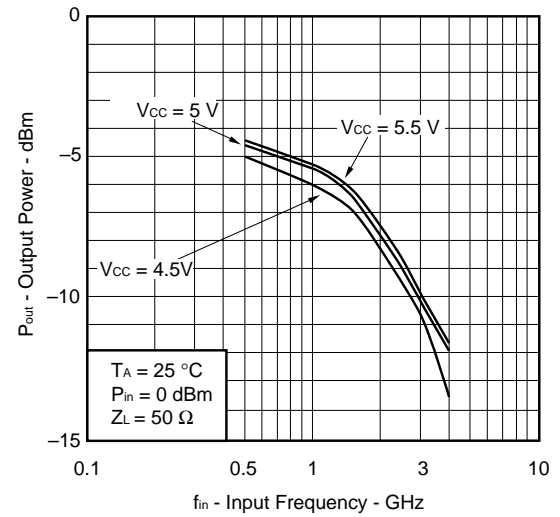

★ TYPICAL CHARACTERISTICS (T_A = 25°C, V_{CC} = 5V, unless otherwise specified)

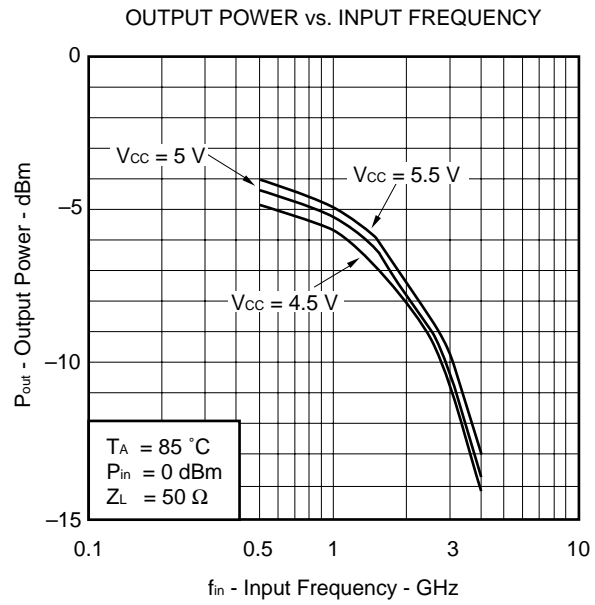
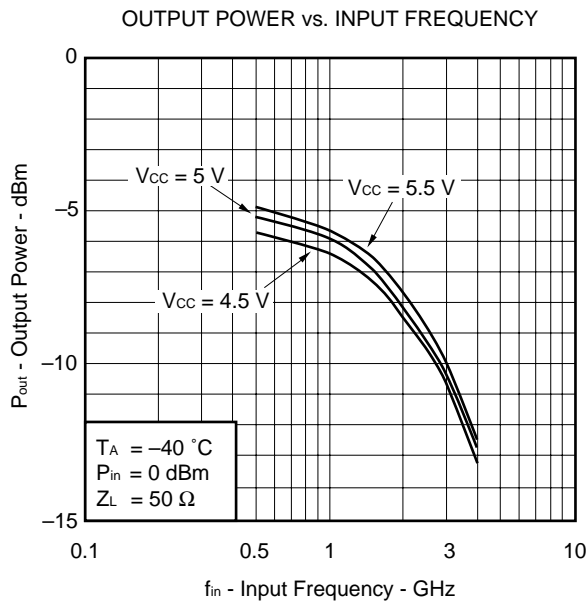

S₁₁ vs. INPUT FREQUENCY

V_{CC} = 5.0 V, T_A = 25°C, Z₀ = 50 Ω

S_{11} Z
 REF 1.0 Units
 4 200.0 mUnits/
 ▽ 27.159 Ω -27.582 Ω
 hp

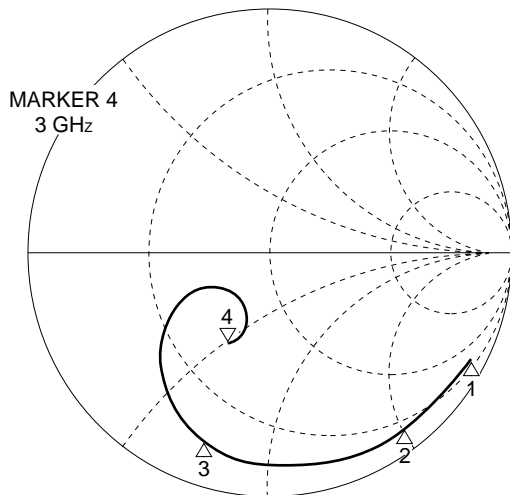

START 0.500000000 GHz
 STOP 3.000000000 GHz

▽1 : 500 MHz
 ▽2 : 1000 MHz
 ▽3 : 2000 MHz
 ▽4 : 3000 MHz

Frequency (MHz)	S ₁₁ (Ω)
500	37.1 - j207.8
1000	14.2 - j105.1
2000	7.9 - j35.8
3000	27.1 - j27.5

S₂₂ vs. OUTPUT FREQUENCY

V_{CC} = 5.0V, f_{in} = 500 MHz, T_A = 25°C, Z_o = 50 Ω

S₂₂ Z
 REF 1.0 Units
 4 200.0 mUnits/
 ▽ 60.925 Ω 104.77 Ω
 hp

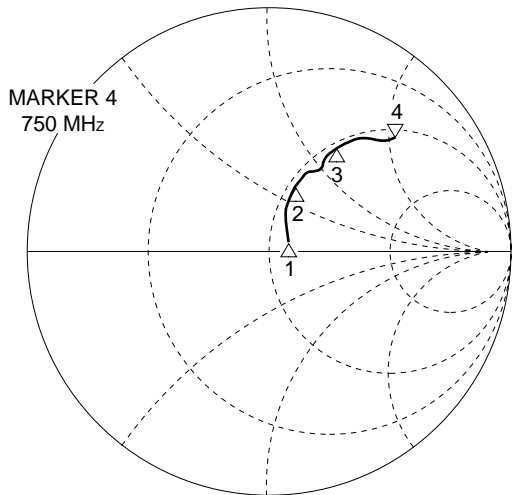

START 0.125000000 GHz
 STOP 0.750000000 GHz

- ▽ 1 : 125 MHz
- ▽ 2 : 250 MHz
- ▽ 3 : 500 MHz
- ▽ 4 : 750 MHz

Frequency (MHz)	S ₂₂ (Ω)
125	55.5 + j6.7
250	53.7 + j30.4
500	55.0 + j60.3
750	60.9 + j104.8

S₂₂ vs. OUTPUT FREQUENCY

V_{CC} = 5.0V, f_{in} = 3 GHz, T_A = 25°C, Z_o = 50 Ω

S₂₂ Z
 REF 1.0 Units
 4 200.0 mUnits/
 ▽ 15.613 Ω 98.168 Ω
 hp

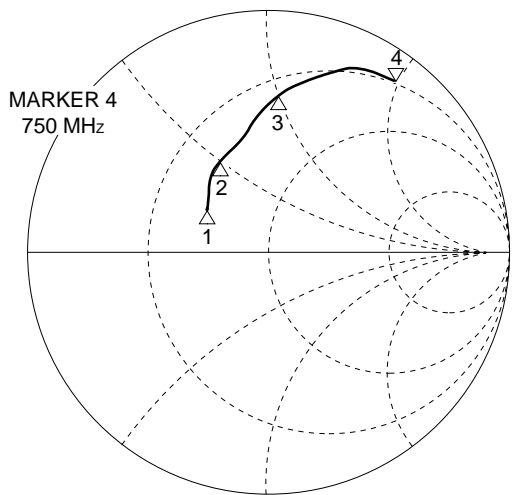

START 0.125000000 GHz
 STOP 0.750000000 GHz

- ▽ 1 : 125 MHz
- ▽ 2 : 250 MHz
- ▽ 3 : 500 MHz
- ▽ 4 : 750 MHz

Frequency (MHz)	S ₂₂ (Ω)
125	28.5 + j11.5
250	27.6 + j23.6
500	20.5 + j50.7
750	15.6 + j98.2

TEST CIRCUIT

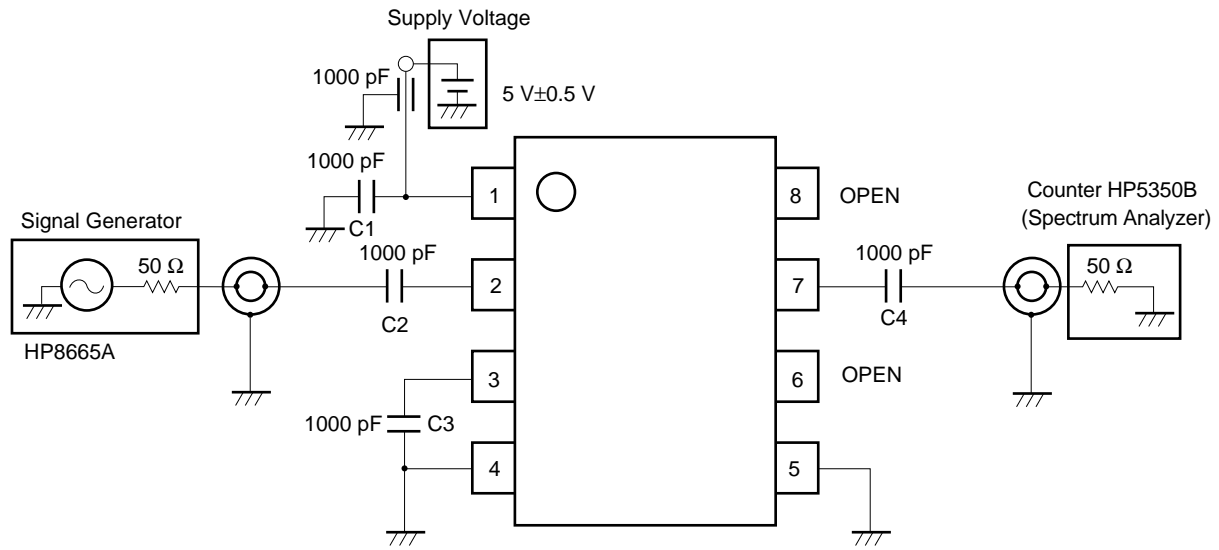
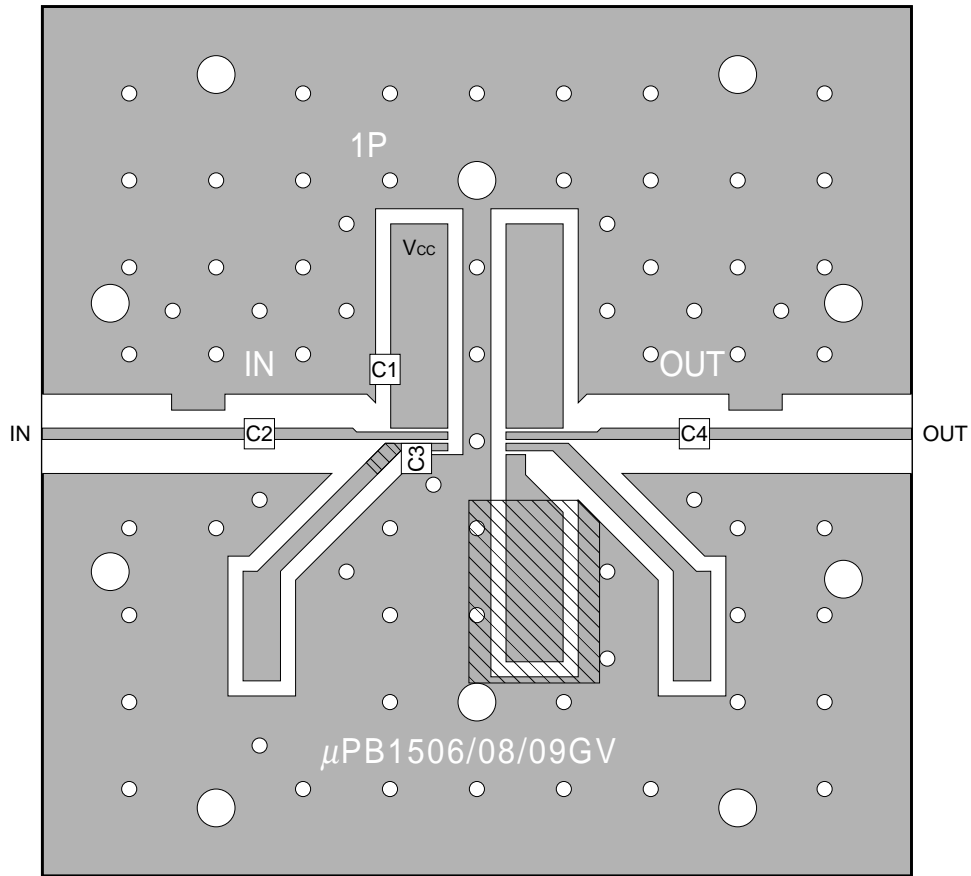

ILLUSTRATION OF THE TEST CIRCUIT ASSEMBLED ON EVALUATION BOARD



COMPONENT LIST

Symbol	Value
C1 to C4	1000 pF

EVALUATION BOARD CHARACTERS

- (1) 35 μm thick double-sided copper clad 50 × 50 × 0.4 mm polyimide board
- (2) Back side: GND pattern
- (3) Solder plated patterns
- (4) ○ : Through holes
- (5) of pin 3 : pattern should be removed.
- (6) of pin 5 : short chip must be attached to be grounded.

The application circuits and their parameters are for reference only and are not intended for use in actual design-ins.

PACKAGE DIMENSIONS

8 PIN PLASTIC SSOP (175 mil) (UNIT: mm)

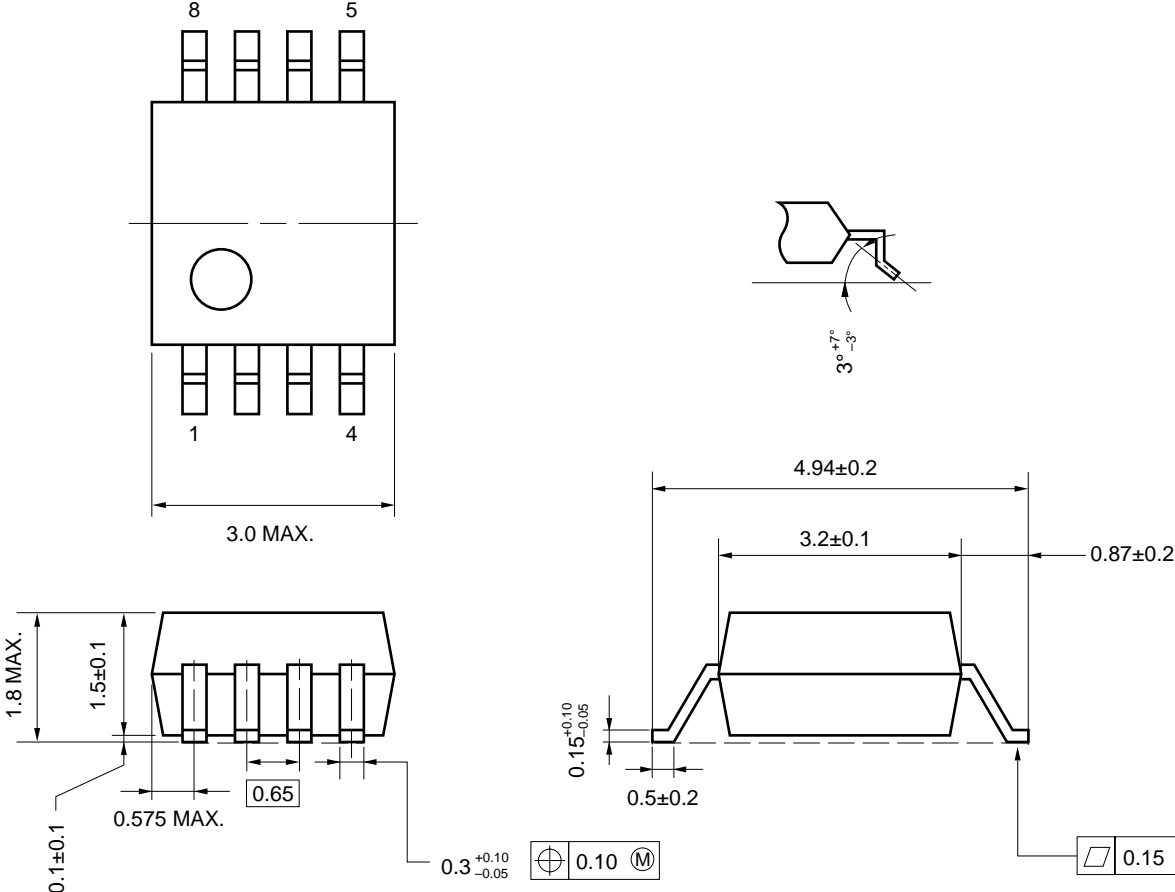

NOTE CORRECT USE

- (1) Observe precautions for handling because of electro-static sensitive devices.
- (2) Form a ground pattern as wide as possible to minimize ground impedance (to prevent undesired operation).
- (3) Keep the wiring length of the ground pins as short as possible.
- (4) Connect a bypass capacitor (e.g. 1 000 pF) to the Vcc pin.

RECOMMENDED SOLDERING CONDITIONS

This product should be soldered under the following recommended conditions. For soldering methods and conditions other than those recommended below, contact your NEC sales representative.

Soldering Method	Soldering Conditions	Recommended Condition Symbol
Infrared Reflow	Package peak temperature: 235 °C or below Time: 30 seconds or less (at 210 °C) Count: 3, Exposure limit ^{Note} : None	IR35-00-3
VPS	Package peak temperature: 215 °C or below Time: 40 seconds or less (at 200 °C) Count: 3, Exposure limit ^{Note} : None	VP15-00-3
Wave Soldering	Soldering bath temperature: 260 °C or below Time: 10 seconds or less Count: 1, Exposure limit ^{Note} : None	WS60-00-1
Partial Heating	Pin temperature: 300 °C Time: 3 seconds or less (per side of device) Exposure limit ^{Note} : None	-

Note After opening the dry pack, keep it in a place below 25 °C and 65 % RH for the allowable storage period.

Caution Do not use different soldering methods together (except for partial heating).

For details of recommended soldering conditions for surface mounting, refer to information document SEMICONDUCTOR DEVICE MOUNTING TECHNOLOGY MANUAL (C10535E).



ATTENTION

OBSERVE PRECAUTIONS
FOR HANDLING
ELECTROSTATIC
SENSITIVE
DEVICES

The application circuits and their parameters are for reference only and are not intended for use in actual design-ins.

NESAT (NEC Silicon Advanced Technology) is a trademark of NEC Corporation.

No part of this document may be copied or reproduced in any form or by any means without the prior written consent of NEC Corporation. NEC Corporation assumes no responsibility for any errors which may appear in this document.

NEC Corporation does not assume any liability for infringement of patents, copyrights or other intellectual property rights of third parties by or arising from use of a device described herein or any other liability arising from use of such device. No license, either express, implied or otherwise, is granted under any patents, copyrights or other intellectual property rights of NEC Corporation or others.

While NEC Corporation has been making continuous effort to enhance the reliability of its semiconductor devices, the possibility of defects cannot be eliminated entirely. To minimize risks of damage or injury to persons or property arising from a defect in an NEC semiconductor device, customers must incorporate sufficient safety measures in its design, such as redundancy, fire-containment, and anti-failure features.

NEC devices are classified into the following three quality grades:

"Standard", "Special", and "Specific". The Specific quality grade applies only to devices developed based on a customer designated "quality assurance program" for a specific application. The recommended applications of a device depend on its quality grade, as indicated below. Customers must check the quality grade of each device before using it in a particular application.

Standard: Computers, office equipment, communications equipment, test and measurement equipment, audio and visual equipment, home electronic appliances, machine tools, personal electronic equipment and industrial robots

Special: Transportation equipment (automobiles, trains, ships, etc.), traffic control systems, anti-disaster systems, anti-crime systems, safety equipment and medical equipment (not specifically designed for life support)

Specific: Aircrafts, aerospace equipment, submersible repeaters, nuclear reactor control systems, life support systems or medical equipment for life support, etc.

The quality grade of NEC devices is "Standard" unless otherwise specified in NEC's Data Sheets or Data Books. If customers intend to use NEC devices for applications other than those specified for Standard quality grade, they should contact an NEC sales representative in advance.

Anti-radioactive design is not implemented in this product.