

## Cascadable Amplifier 10 to 500 MHz

Rev. V2

### Features

- HIGH GAIN-TWO STAGES: 30 dB (TYP.)
- LOW POWER DRAIN 65 mW @ 5 VOLTS (TYP.)
- VOLTAGE CONTROLLED GAIN 27 dB TO 34 dB @  $V_{CC} = 3$  TO 12 VOLTS
- LOW VSWR 1.3:1 (TYP.)

### Description

The A83 RF amplifier is a discrete hybrid design, which uses thin film manufacturing processes for consistent performance and high reliability.

This 2 stage bipolar transistor feedback amplifier design displays impressive performance over a broadband frequency range. An active DC biasing network insures temperature-stable performance.

Both TO-8 and Surface Mount packages are hermetically sealed, and MIL-STD-883 environmental screening is available.

### Ordering Information

Part Number	Package
MAAM-008200-000A83	TO-8
MAAM-008200-0SMA83	Surface Mount
MAAM-008200-00CA83	SMA Connectorized **

\*\* The connectorized version is not RoHs compliant.

### Product Image

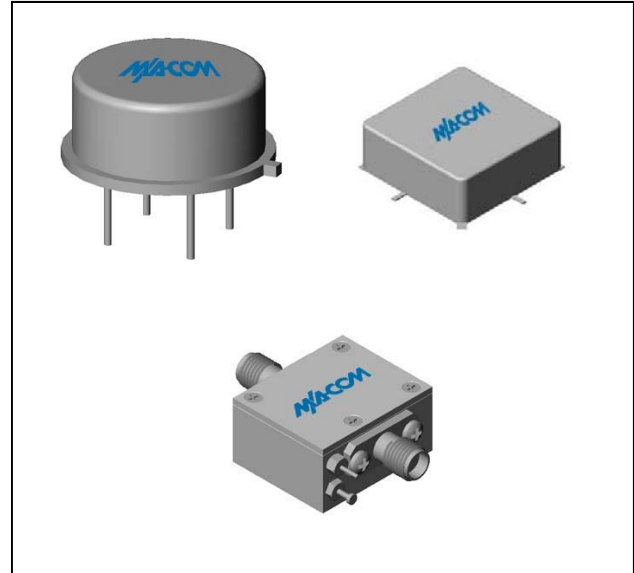

### Electrical Specifications: $Z_0 = 50\Omega$ , $V_{CC} = +15 V_{DC}$

Parameter	Units	Typical	Guaranteed	
		25°C	0° to 50°C	-54° to +85°C*
Frequency	MHz	10-600	10-500	10-500
Small Signal Gain (min)	dB	30.0	29.0	28.0
Gain Flatness (max)	dB	±0.3	±0.5	±0.8
Reverse Isolation	dB	40		
Noise Figure (max)	dB	3.0	3.5	4.0
Power Output @ 1 dB comp. (min)	dBm	-1.0	-2.0	-4.0
IP3	dBm	+10		
IP2	dBm	+14		
Second Order Harmonic IP	dBm	+20		
VSWR Input / Output (max)		1.3:1 / 1.3:1	1.8:1 / 1.8:1	2.0:1 / 2.0:1
DC Current @ 15 Volts (max)	mA	13	15	16

### Absolute Maximum Ratings

Parameter	Absolute Maximum
Storage Temperature	-62°C to +125°C
Case Temperature	+125°C
DC Voltage	+13 V
Continuous Input Power	+6 dBm
Short Term Input power (1 minute max.)	50 mW
Peak Power (3 µsec max.)	0.5 W
"S" Series Burn-In Temperature (case)	+125°C

### Thermal Data: $V_{CC} = +15 V_{DC}$

Parameter	Rating
Thermal Resistance $\theta_{jc}$	45°C/W
Transistor Power Dissipation $P_d$	0.193 W
Junction Temperature Rise Above Case $T_{jc}$	9°C

\* Over temperature performance limits for part number CA83, guaranteed from 0°C to +50°C only.

**ADVANCED:** Data Sheets contain information regarding a product M/A-COM Technology Solutions is considering for development. Performance is based on target specifications, simulated results, and/or prototype measurements. Commitment to develop is not guaranteed.

**PRELIMINARY:** Data Sheets contain information regarding a product M/A-COM Technology Solutions has under development. Performance is based on engineering tests. Specifications are typical. Mechanical outline has been fixed. Engineering samples and/or test data may be available. Commitment to produce in volume is not guaranteed.

• **North America** Tel: 800.366.2266 • **Europe** Tel: +353.21.244.6400  
 • **India** Tel: +91.80.4155721 • **China** Tel: +86.21.2407.1588  
 Visit [www.macomtech.com](http://www.macomtech.com) for additional data sheets and product information.

M/A-COM Technology Solutions Inc. and its affiliates reserve the right to make changes to the product(s) or information contained herein without notice.

# A83 / SMA83

Cascadable Amplifier  
10 to 500 MHz

Rev. V2

## Typical Performance Curves at +25°C

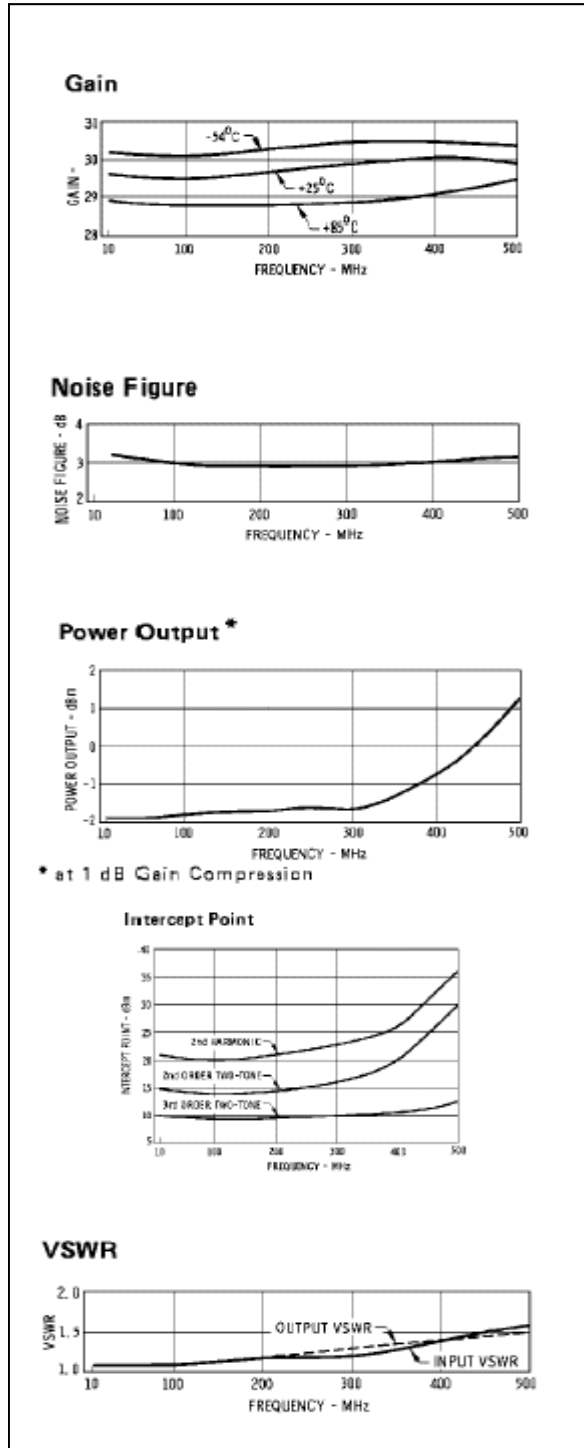

## Outline Drawing: TO-8 \*

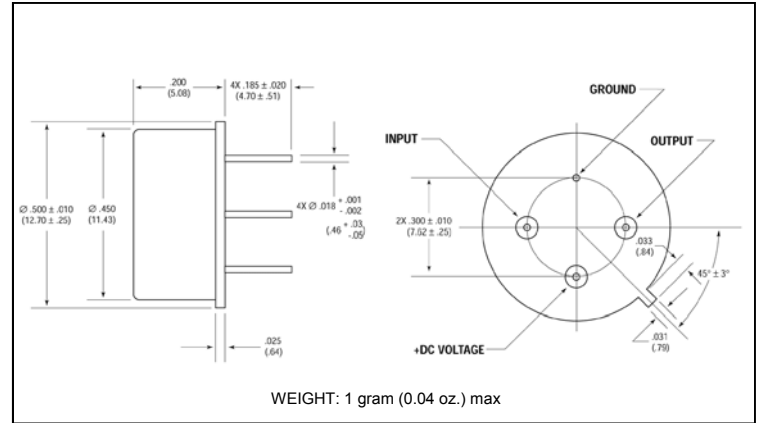

## Outline Drawing: Surface Mount \*

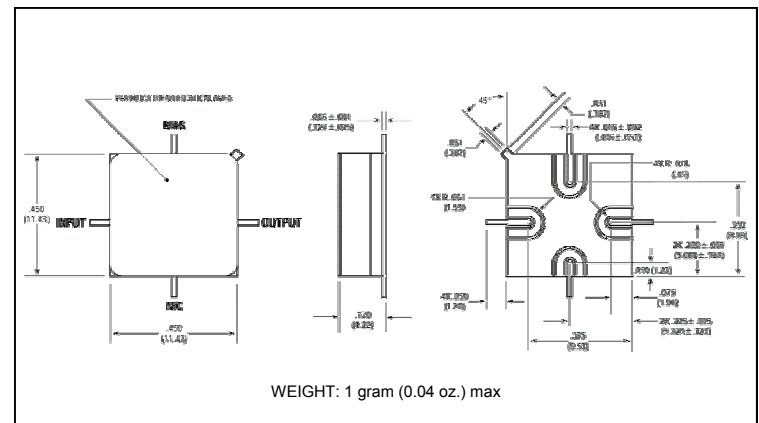

## Outline Drawing: SMA Connectorized \*

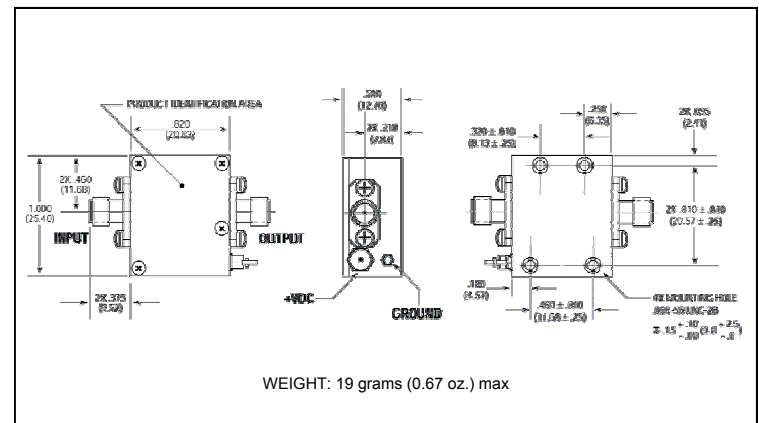

\* Dimensions are inches (millimeters)  $\pm 0.015$  (0.38) unless otherwise specified.

**ADVANCED:** Data Sheets contain information regarding a product M/A-COM Technology Solutions is considering for development. Performance is based on target specifications, simulated results, and/or prototype measurements. Commitment to develop is not guaranteed.  
**PRELIMINARY:** Data Sheets contain information regarding a product M/A-COM Technology Solutions has under development. Performance is based on engineering tests. Specifications are typical. Mechanical outline has been fixed. Engineering samples and/or test data may be available. Commitment to produce in volume is not guaranteed.

• **North America** Tel: 800.366.2266 • **Europe** Tel: +353.21.244.6400  
 • **India** Tel: +91.80.4155721 • **China** Tel: +86.21.2407.1588  
 Visit [www.macomtech.com](http://www.macomtech.com) for additional data sheets and product information.

M/A-COM Technology Solutions Inc. and its affiliates reserve the right to make changes to the product(s) or information contained herein without notice.