

**LO Buffer Amplifier**  
900 - 2000 MHz

MAAM-007217  
V2

**Features**

- High Gain 2-Stage Amplifier
- Single Supply, 3V Operation
- High Reverse Isolation
- Low Current
- Broadband Operation
- Lead-Free SOT-143 Package
- 100% Matte Tin Plating over Copper
- Halogen-Free "Green" Mold Compound
- 260°C Reflow Compatible
- RoHS\* Compliant version of MAAMSS0005

**Description**

M/A-COM's MAAM-007217 is a low current, high reverse isolation LO buffer amplifier in a low cost, lead-free SOT-143 plastic package. The MAAM-007217 is ideally suited for LO buffer handset applications in the Cellular, GPS and PCS frequency bands.

The MAAM-007217 is fabricated using M/A-COM's 0.5 micron low noise E/D GaAs MESFET process. The process features full passivation for increased performance and reliability.

**Ordering Information**<sup>1</sup>

Part Number	Package
MAAM-007217-000000	Bulk Packaging
MAAM-007217-TR3000	3000 piece reel

1. Reference Application Note M513 for reel size information.

**Recommended PCB Configuration**

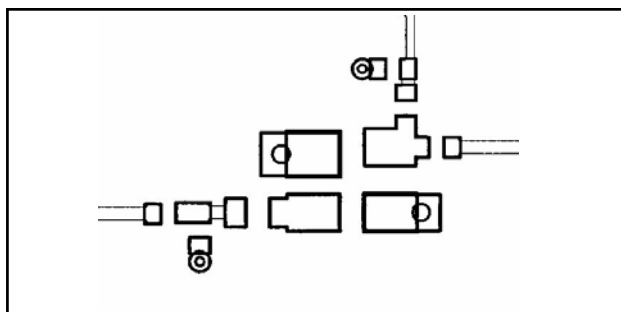

**Block Diagram**

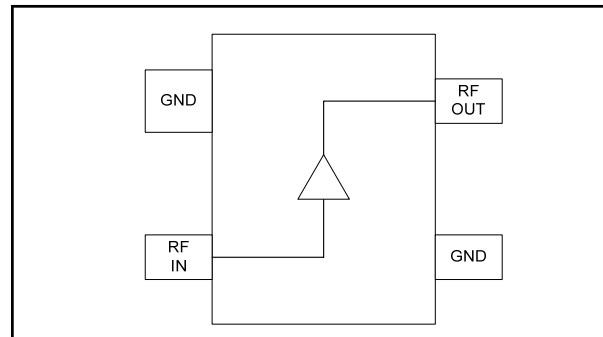

**Pin Configuration**

Pin No.	Function	Pin No.	Function
1	GND	3	GND
2	RF IN	4	RF OUT

**Absolute Maximum Ratings**<sup>2,3</sup>

Parameter	Absolute Maximum
Vbias	6.0 V
Max Input Level	0 dBm
Operating Temperature	-30°C to +85°C
Storage Temperature	-65°C to +150°C

2. Exceeding any one or combination of these limits may cause permanent damage to this device.
3. M/A-COM does not recommend sustained operation near these survivability limits.

**Handling Procedures**

Please observe the following precautions to avoid damage:

**Static Sensitivity**

Gallium Arsenide Integrated Circuits are sensitive to electrostatic discharge (ESD) and can be damaged by static electricity. Proper ESD control techniques should be used when handling these devices.

\* Restrictions on Hazardous Substances, European Union Directive 2002/95/EC.

**LO Buffer Amplifier  
900 - 2000 MHz**

**MAAM-007217  
V2**

**Electrical Specifications - Cellular Band (965 - 975 MHz):  $T_A = 25^\circ\text{C}$ ,  $V_{DD} = 3.0\text{ V}$ ,  $Z_0 = 50\ \Omega$**

Parameter	Test Conditions	Units	Min	Typ	Max
Gain	—	dB	13.0	15.5	17.0
Noise Figure	—	dB	—	2.8	—
VSWR In/Out	—	Ratio	—	1.4:1	—
Output P1dB	—	dBm	—	6	—
Reverse Isolation	—	dB	30	35	—
Output IP3	—	dBm	—	+17	—
I <sub>dd</sub>	—	mA	—	5	7

**Electrical Specifications - PCS Band (1580 - 1780 MHz):  $T_A = 25^\circ\text{C}$ ,  $V_{DD} = 3.0\text{ V}$ ,  $Z_0 = 50\ \Omega$**

Parameter	Test Conditions	Units	Min.	Typ.	Max.
Gain	—	dB	—	10.0	—
Noise Figure	—	dB	—	3.6	—
VSWR In/Out	—	Ratio	—	1.6:1	—
Output P1dB	—	dBm	—	4	—
Reverse Isolation	—	dB	—	36	—
Output IP3	—	dBm	—	+16	—
I <sub>dd</sub>	—	mA	—	5	7

**Lead Free SOT-143 †**

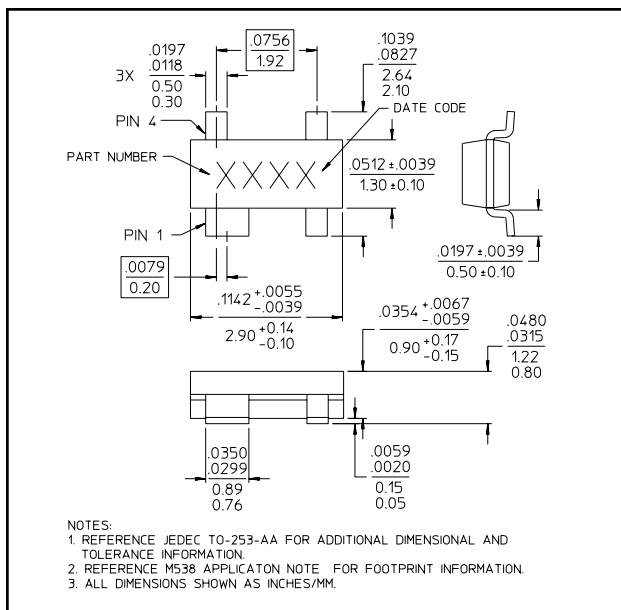

† Reference Application Note M538 for lead-free solder reflow recommendations.

**Sample Board Schematic**

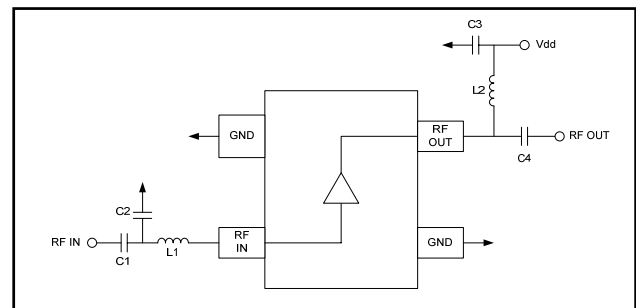

**External Circuitry Parts List**

Part	Value (Cellular/PCS)	Purpose
C1	1000 pF	DC Block
C2	3.3 pF / 2.2 pF	RF Matching
C3	0.1 $\mu\text{F}$	Bypass
C4	1.2 pF / 1.0 pF	RF Matching
L1	30 nH / 10 nH	RF Matching
L2	12 nH / 5.1 nH	RF Matching

**Typical Performance Curves vs. Temperature - Cellular Frequency Band  $V_{DD} = 3\text{ V}$**

**Input Return Loss**

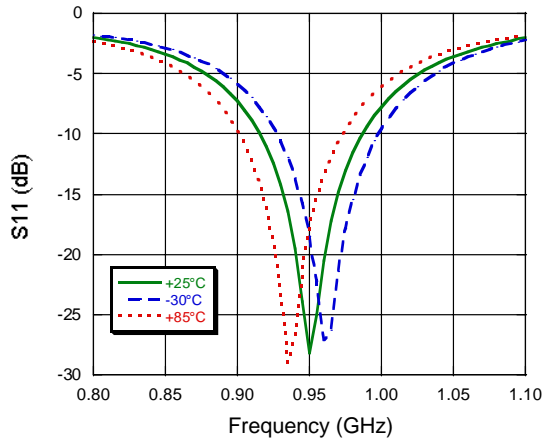

**Output Return Loss**

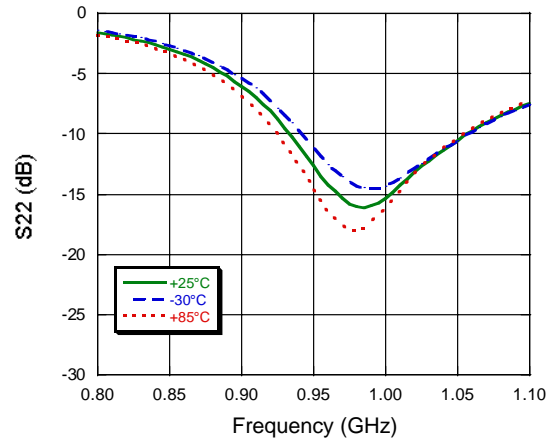

**Gain**

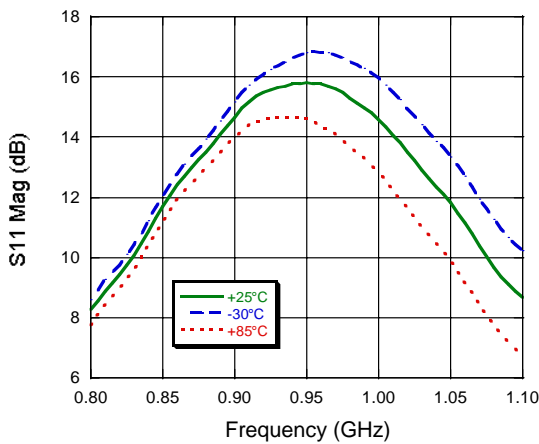

**Reverse Isolation**

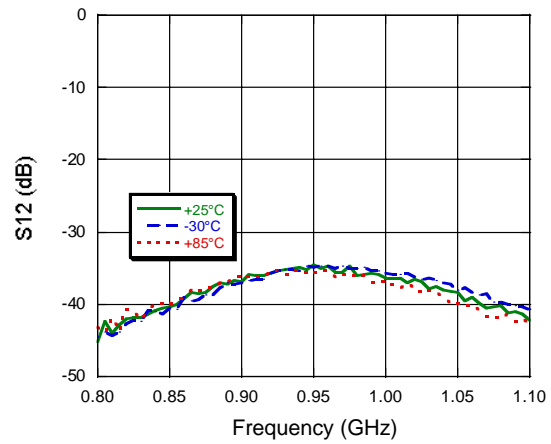

**Noise Figure**

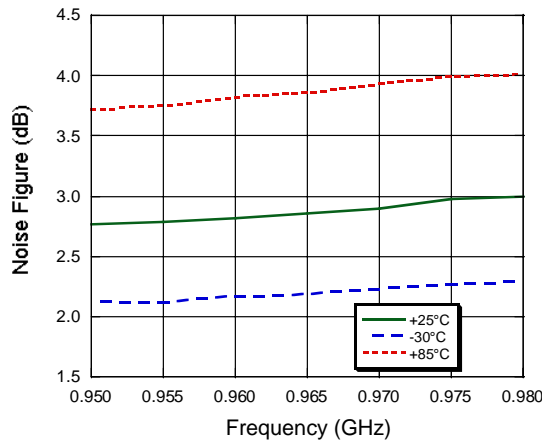

**P1dB @ 965 MHz**

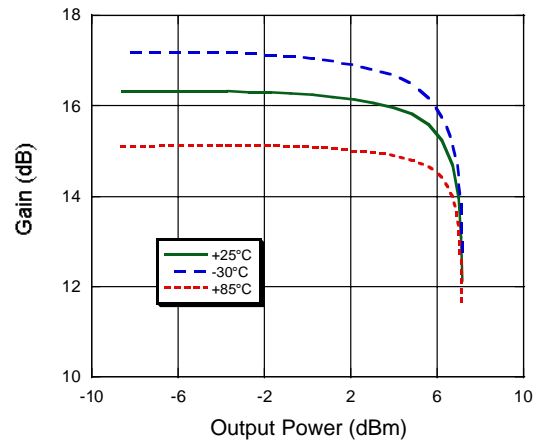

**Typical Performance Curves vs. Temperature - PCS Frequency Band  $V_{DD} = 3 V$**

**Input Return Loss**

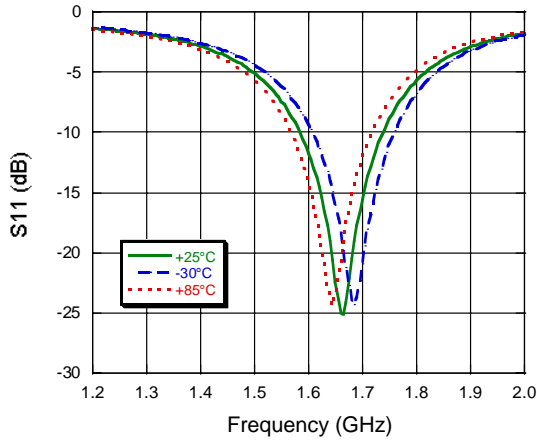

**Output Return Loss**

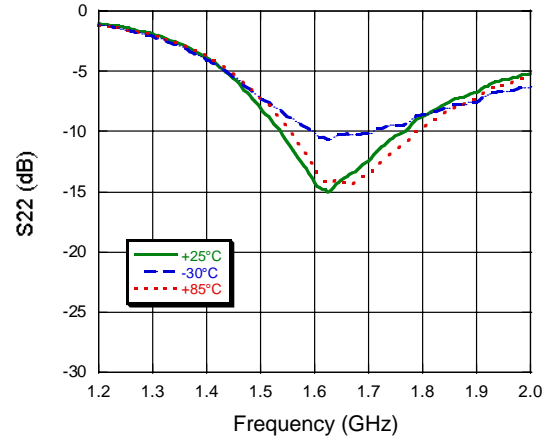

**Gain**

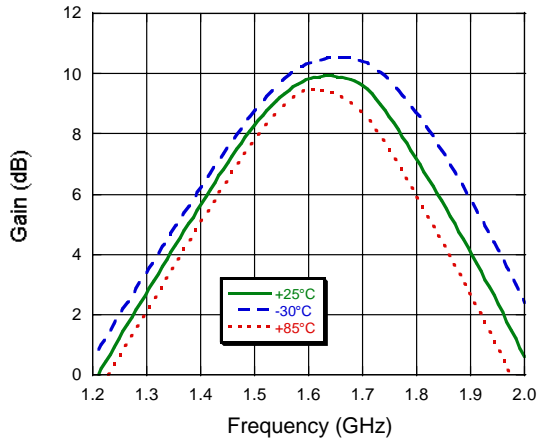

**Reverse Isolation**

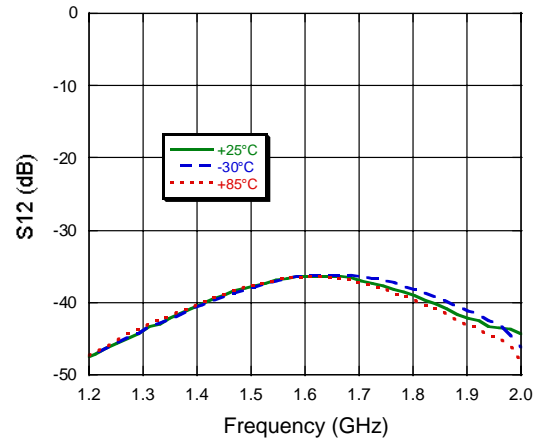

**Noise Figure**

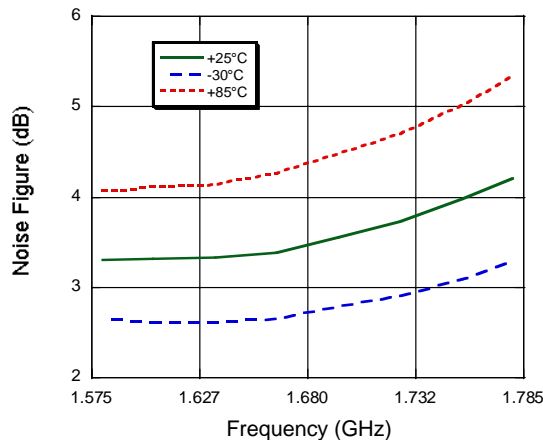

**P1dB @ 1635 MHz**

