

Portrait-type 8.9 cm (3.5-type) QVGA Reflective Color LCD Module
with Built-in Touch Panel and 4-bit D/A Converter

ACX706AKM

To provide color display for PDAs and other portable information terminals, Sony has now developed the ACX706AKM 8.9 cm (3.5-type) portrait-type QVGA color LCD module based on low-temperature polycrystalline silicon reflective LCD technology.

This new product adopts a full module form that consists of a portrait-type LCD panel with a built-in 4-bit D/A converter, a newly-developed thin high-efficiency LED front light, and a touch panel optimized for use with reflective LCD panels. The result is a high-brightness, high image quality, low-power (65 mW) LCD module.

Additionally, Sony has integrated the controller and driver functions that have conventionally been implemented with two chips in a single chip in the newly-developed CXD3513GG for simplification of the total system.

- QVGA reflective color LCD module
- 240 × RGB × 320 vertical stripe arrangement
- TFT panel with built-in 4-bit D/A converter
- Thin high-efficiency new LED front light
- High transmittance touch panel
- Low power consumption: 65 mW (with the front light off)

■ LCD Full Module Form Includes Touch Panel

The newly-developed ACX706AKM is Sony's first full module form, and as such includes an LCD panel, a front light, and a touch panel. By adopting the full module form, Sony was able to optimize the optical design of the touch panel, the front light, and the high reflection ratio panel that is based on the RMP (random multi-profile) structure and an advanced BDM design retardation film. This also allowed optimal matching of the polarizers. As a result, this product achieves, even with the touch panel included, a high contrast ratio (12:1 typical) and a high reflection ratio (24% typical). An anti-

reflective coating applied to the touch panel allows this device to be used outdoors.

■ Thin High-Efficiency Newly-Developed LED Front Light

The ACX706AKM adopts a newly-developed ultrasmall white LED, and features an optimized optical design that allows it to achieve a brightness of 5 cd/m² (typical) at a power consumption of 105 mW (typical). Furthermore, in addition to the LED front light featuring a rapid turn-on time, it also features superlative brightness stability at low temperatures. Thus this device supports use in a wide range of operating environments.

■ Low-Power Panel and Newly-Developed Single Chip IC

The ACX706AKM panel takes advantage of Sony's unique circuit and low-temperature polycrystalline silicon TFT technologies developed in previous 2.7-type and 3.8-type panels, and achieves high reliability, high quality, and low power (the panel itself consumes 20 mW). Furthermore, Sony has integrated the controller and driver functions that have conventionally been implemented with two chips in a single chip in the newly-developed CXD3513GG. The integration of these functions on a single chip increases the degrees of freedom available to the PWB layout designer, and achieves the low power consumption of 65 mW (with the front light off) when the panel is actually driven.

Following the development of 2.7-type and 3.8-type panels, Sony has now added the newly-developed ACX706AKM 3.5-type portrait-type LCD panel to its product line of reflective LCD products to respond to a wide range of needs in the portable information terminal area.

V O I C E

While this is our third reflective display module, it is no way inferior to either of the others.

I hope you will consider the ACX706AKM 3.5-type LCD, which is optimal for portable information terminals. I'm sure that, once you see it, you will be able to image a wide range of applications for this module.



New Products

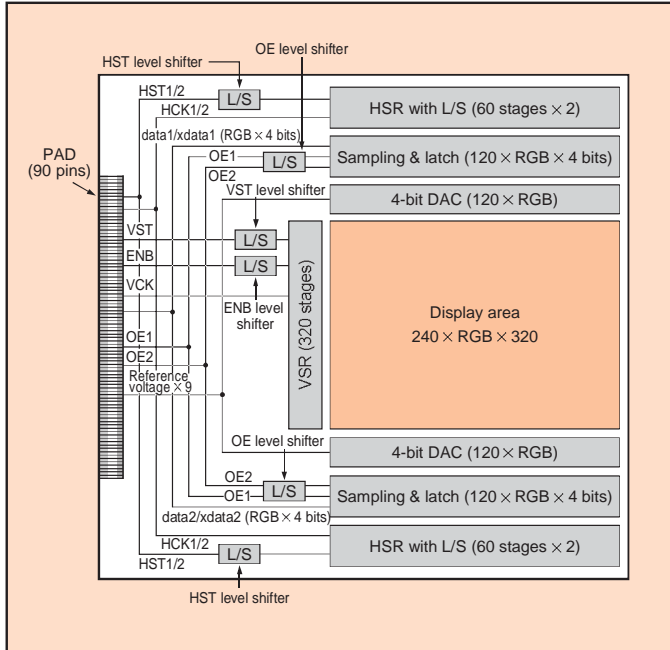

■ Figure 1 ACX706AKM Block Diagram

■ Table 1 ACX706AKM Basic Specifications

Item	Preliminary specification
Module structure	LCD + F/L + T/P
Screen size	53.28 mm (W) × 71.04 mm (H) : 8.9 cm diagonal (3.5-type)
Aspect ratio	3 : 4
Number of effective dots	QVGA [240 (H) × RGB × 320 (V)] 230.4K dots
Contrast ratio	12:1 Typ. (F/L off) 7:1 Typ. (F/L on)
Reflection ratio	Typ. 24 %
Number of colors	Four bits for each of RGB (4096 colors)
Supply voltage	-6.5 V, +9 V
Power consumption/ brightness	65 mW Typ. (F/L off) 170 mW Typ. (F/L on) (at 25 °C)
Module dimensions	66.2 mm (W) × 88.0 mm (H) × 6.0 mm (t)
Operating temperature	-10 to +60°C
Storage temperature	-20 to +70°C

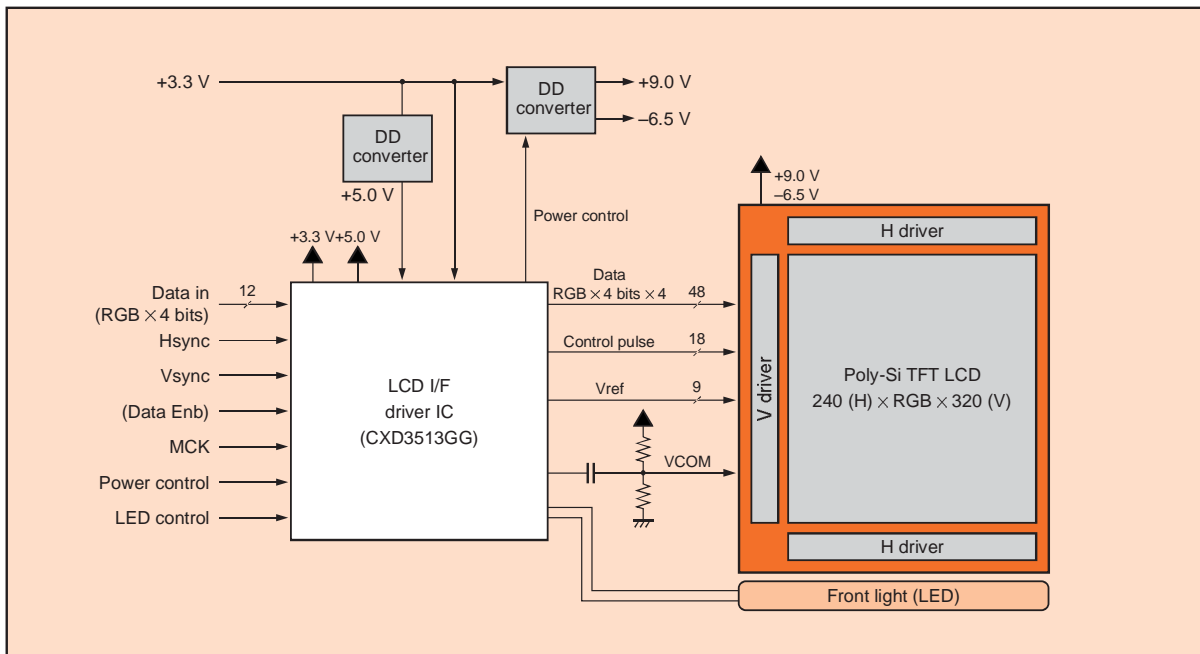

■ Figure 2 ACX706AKM System Block Diagram