

8.80cm (3.5 Type) NTSC/PAL Color LCD Panel

Description

The ACX302AK is a 8.80cm diagonal active matrix TFT-LCD panel addressed by low temperature polycrystalline silicon transistors with built-in peripheral driving circuitry. This panel provides full-color representation for NTSC and PAL systems. In addition, RGB dots are arranged in a delta pattern that provides smooth picture quality without fixed color patterns compared to vertical stripe and mosaic patterns.

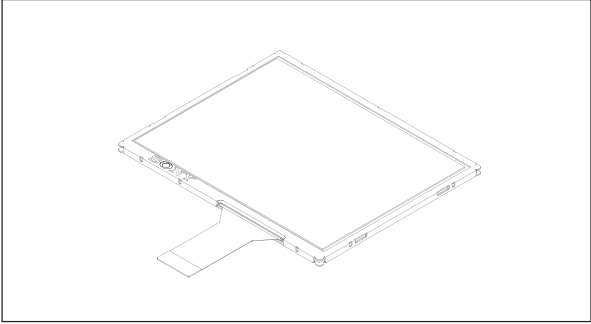

Features

- Number of active dots: 200,000, 8.80cm (3.5 Type) in diagonal
- Horizontal resolution: 440 TV lines
- Optical transmittance: 8.2% (typ.)
- High contrast ratio with normally white mode: 200 (typ.)
- Built-in H and V driving circuitry (built-in input level conversion circuit, 3V drive possible)
- Low voltage, low power consumption 12V drive: 60mW (typ.)
- Smooth pictures with a RGB delta arrangement
- Supports NTSC/PAL
- Built-in picture quality improvement circuit
- Up/down and/or right/left inverse display function
- 16:9 screen display function
- AR (anti-reflectance) surface treatment provides an easy-to-see display even outdoors
- Dirt-resistant surface treatment
- Narrow frame
- High color reproductivity

Element Structure

- Active matrix TFT-LCD panel with built-in peripheral driving circuitry using low temperature polycrystalline silicon transistors
- Number of pixels
 - Total number of dots : 884 (H) × 230 (V) = 203,320
 - Number of active dots : 880 (H) × 228 (V) = 200,640
- Panel dimensions
 - Package dimensions : 78.8 (W) × 63.3 (D) × 2.2 (H) (mm)
 - Effective display dimensions : 70.400 (H) × 52.725 (V) (mm)

Applications

LCD monitors, etc.

Sony reserves the right to change products and specifications without prior notice. This information does not convey any license by any implication or otherwise under any patents or other right. Application circuits shown, if any, are typical examples illustrating the operation of the devices. Sony cannot assume responsibility for any problems arising out of the use of these circuits.

Block Diagram

The panel block diagram is shown below.

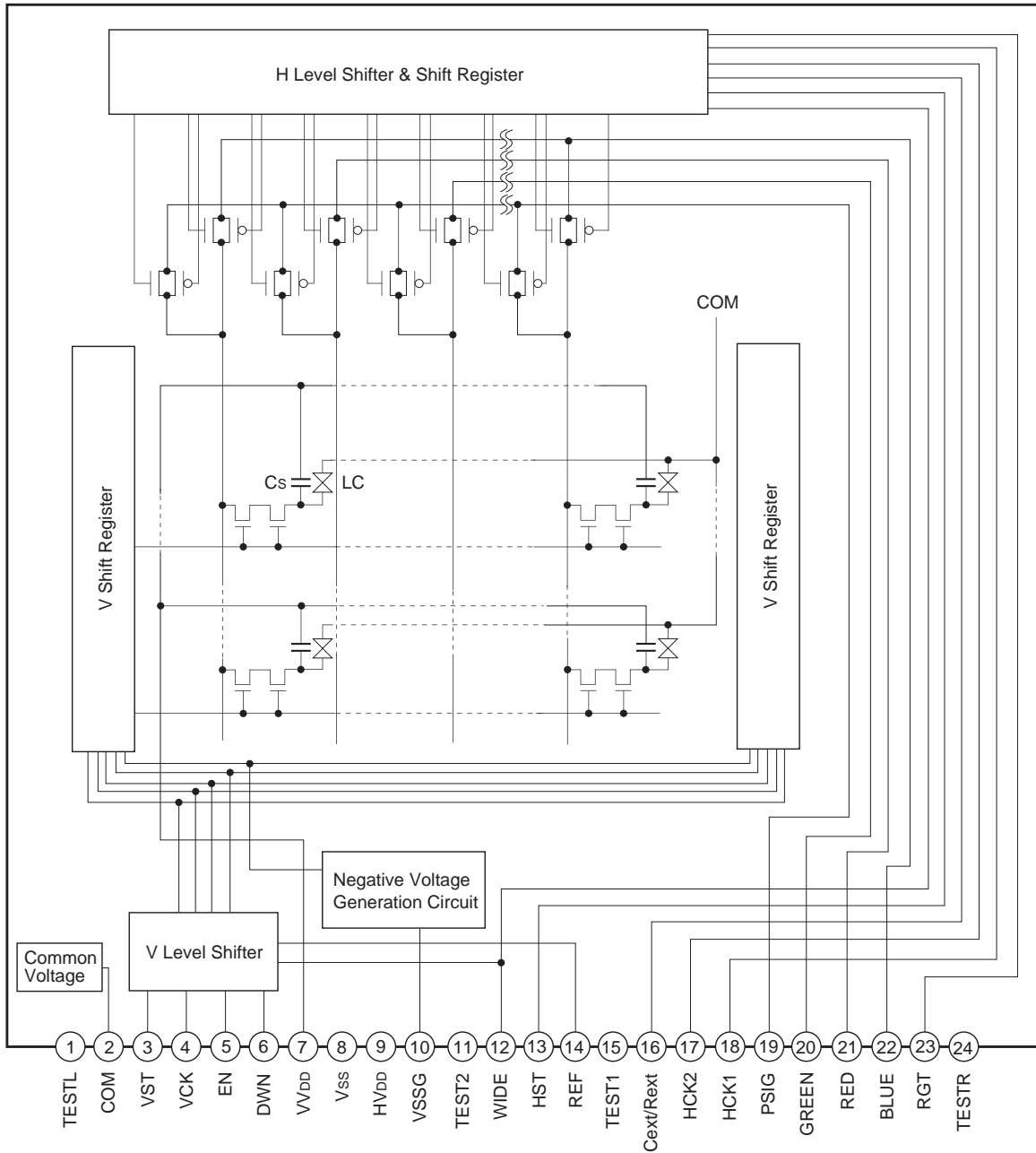

Absolute Maximum Ratings (V_{SS} = 0V)

• H driver supply voltage	HV _{DD} , Cext/Rext	-1.0 to +17	V
• V driver supply voltage	VV _{DD}	-1.0 to +15	V
• V driver negative supply voltage	VSSG	-3.0 to +1.0	V
• Common voltage of panel	COM	-1.0 to +17	V
• H driver input pin voltage	HST, HCK1, HCK2, RGT, WIDE	-1.0 to +17	V
• V driver input pin voltage	VST, VCK, EN, DWN, REF	-1.0 to +15	V
• Video signal, uniformity improvement signal input pin voltage	GREEN, RED, BLUE, PSIG	-1.0 to +13	V
• Operating temperature	T _{opr}	-10 to +60	°C
• Storage temperature	T _{stg}	-30 to +85	°C

Operating Conditions

1. Input/output supply voltage conditions*1

(V_{SS} = 0V)

Item	Symbol	Min.	Typ.	Max.	Unit
Supply voltage	HV _{DD}	11.4	12.0/13.5	14.0	V
	VV _{DD}	11.4	12.0/13.5	14.0	V
	Cext/Rext*2	HV _{DD} - 2.0	12.0/13.5	—	V
VSSG output voltage setting*3	VSSG	-2.3	-1.8	-1.5	V

*1 The HV_{DD}/VV_{DD} typical voltage setting is noted as 12.0V in these specifications.

*2 Connect the resistor and capacitor to the Cext/Rext pin as shown in the figure below.

*3 For the VSSG output setting, connect an external smoothing capacitor and a voltage stabilizing Zener diode as shown in the figure below.

The Cext/Rext value differs according to the rising time of the panel supply voltage.

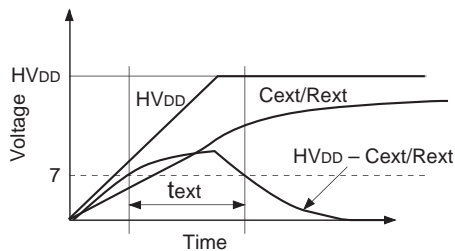

Set a Cext value that satisfies t_{text} > 1ms.

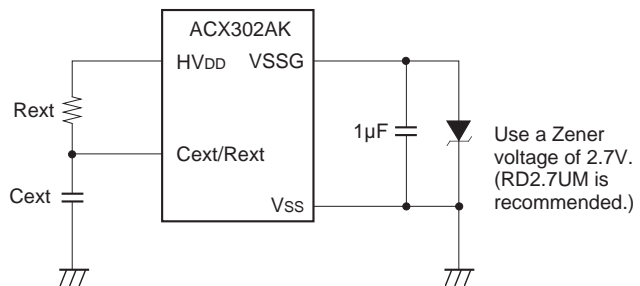

2. Input signal voltage conditions

(Vss = 0V)

Item		Symbol	Min.	Typ.	Max.	Unit
H/V driver input voltage	(Low)	VIL	-0.3	0.0	0.3	V
	(High)	VIH	2.6	3.0	5.5	V
REF input voltage		VREF	VIH/2 - 0.3	VIH/2	VIH/2 + 0.3	V
Video signal center voltage		VVC	5.3	5.5	5.7	V
Video signal input range		Vsig	1.0	VVC ± 4.0	VDD - 2.0 (however, 10V or less)	V
Uniformity improvement signal		Vpsig	VVC ± 2.3	VVC ± 2.5	VVC ± 2.7	V
16:9 display top/bottom black signal*4		VpsigBK		VVC ± 4.0	VVC ± 4.5	V
Common voltage of panel (Ta = 25°C)		Vcom	VVC - 0.4	VVC - 0.3	VVC - 0.2	V

*4 Input video and uniformity improvement signals should be symmetrical to VVC. The input conditions for the uniformity improvement signal Vpsig differ for 4:3 display and 16:9 display.

- 1) During 4:3 display, input the voltage amplitude symmetrical to VVC as shown in Fig. 1.
- 2) During 16:9 display, input the same signal amplitude as in 1) above during the effective display portion, and input the black signal level VpsigBK during the top/bottom black input portion as shown in Fig. 2.

During 4:3 display

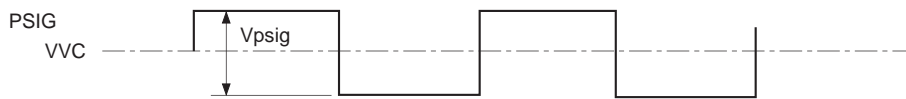

Fig. 1

During 16:9 display

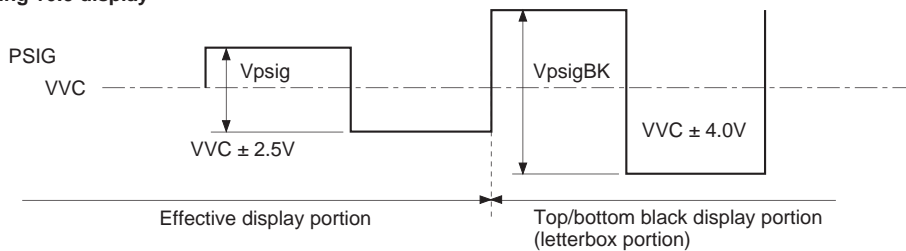

Fig. 2

Pin Description

Pin No.	Symbol	Description	Pin No.	Symbol	Description
1	TESTL	Panel test output; no connection	13	HST	Start pulse input for H shift register drive
2	COM	Common voltage input of panel	14	REF	Level shifter circuit REF voltage input
3	VST	Start pulse input for V shift register drive	15	TEST1	Panel test output; no connection
4	VCK	Clock input for V shift register drive	16	Cext/ Rext	Time constant power supply input for H shift register drive
5	EN	Gate selection pulse enable input	17	HCK2	Clock input for H shift register drive
6	DWN	V shift register drive direction signal input	18	HCK1	Clock input for H shift register drive
7	VV _{DD}	Power supply input for V driver	19	PSIG	Uniformity improvement signal input
8	V _{SS}	H and V driver GND	20	GREEN	Video signal (G) input to panel
9	HV _{DD}	Power supply input for H driver	21	RED	Video signal (R) input to panel
10	VSSG	Negative power supply setting for V driver	22	BLUE	Video signal (B) input to panel
11	TEST2	Test; no connection	23	RGT	H shift register drive direction signal input
12	WIDE	Pulse input for 16:9 mode	24	TESTR	Panel test output; no connection

Input Equivalent Circuits

To prevent static charges, protective diodes are provided for each pin except the power supplies. In addition, protective resistors are added to all pins except the video signal input pins. All pins are connected to Vss with a high resistance of 1MΩ (typ.). The equivalent circuit of each input pin is shown below: (Resistor value: typ.)

(1) RED, GREEN, BLUE, PSIG

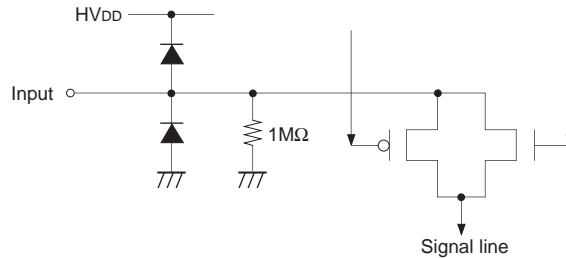

(2) HCK1, HCK2

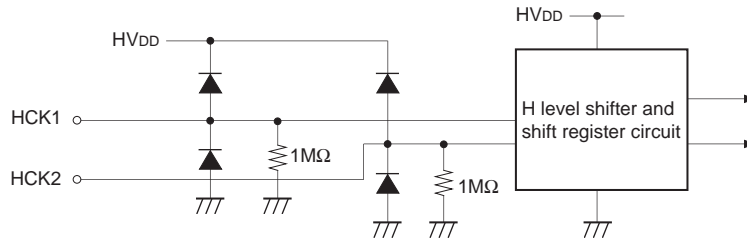

(3) HST, WIDE, REF

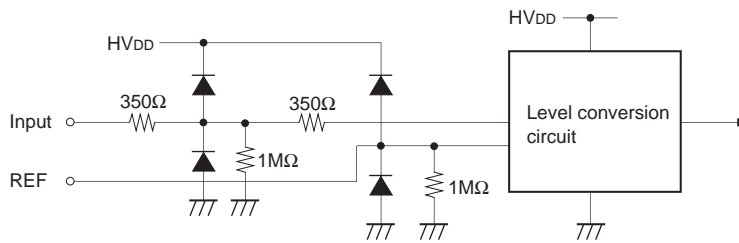

(4) RGT, REF

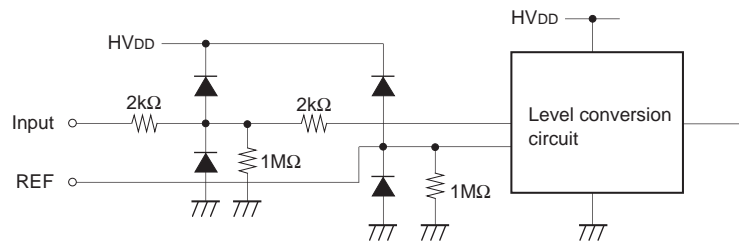

(5) VST, VCK, EN, REF

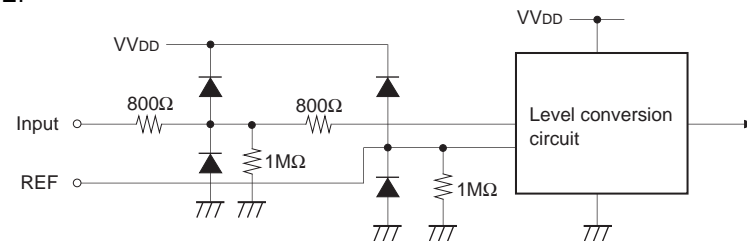

(6) DWN, REF

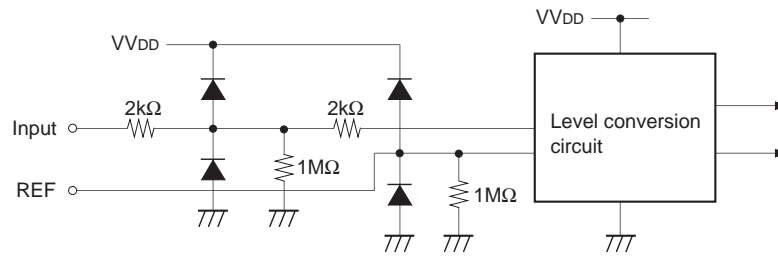

(7) VSSG

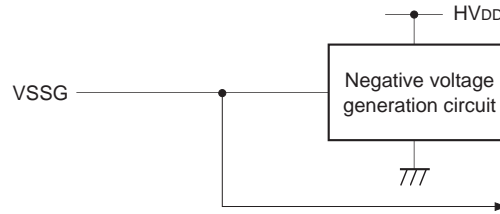

(8) COM

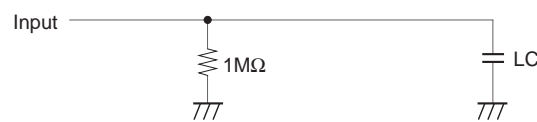

(9) Cext/Rext

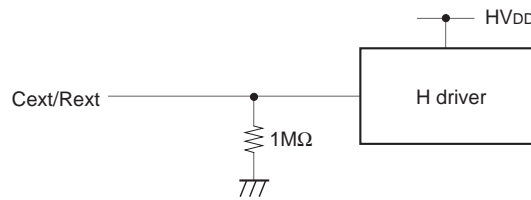

(10) TEST1/TEST2

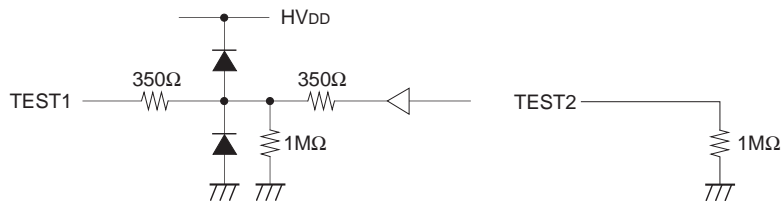

(11) TESTL, TESTR

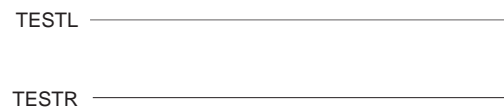

Clock Timing Conditions

(VIH = 3.0V, HVDD = VVDD = 12V, Ta = 25°C)

	Item	Symbol	Min.	Typ.	Max.	Unit
HST	HST rise time	trHst	—	—	30	ns
	HST fall time	tfHst	—	—	30	
	HST data setup time	tdHst	137	167	197	
	HST data hold time	thHst	-30	0	30	
HCK	HCKn rise time	trHckn	—	—	30	ns
	HCKn fall time	tfHckn	—	—	30	
	HCK1*5 fall to HCK2 rise time	to1Hck	-15	0	15	
	HCK1*5 rise to HCK2 fall time	to2Hck	-15	0	15	
VST	VST rise time	trVst	—	—	100	μs
	VST fall time	tfVst	—	—	100	
	VST data setup time	tdVst	30	32	34	
	VST data hold time	thVst	-34	-32	-30	
VCK	VCK rise time	trVckn	—	—	100	ns
	VCK fall time	tfVckn	—	—	100	
EN	EN rise time	trEn	—	—	100	ns
	EN fall time	tfEn	—	—	100	
	EN rise to VCK rise/fall time	tdEn	2400	2500	2600	
	EN pulse width	twEn	5400	5500	5600	
WIDE	WIDE rise time	trWide	—	—	100	μs
	WIDE fall time	tfWide	—	—	100	
	WIDE (H) rise to VCK rise/fall time	tdhWide	0.9	1.1	1.3	
	WIDE (H) pulse width	twhWide	2.8	3.0	3.3	
	WIDE (V) pulse width	twvWide	1928	1933	1938	
	WIDE (V) fall to EN rise time	tov1Wide	25	32	—	
	EN fall to WIDE (V) fall time	tov2Wide	25	32	—	

*5 HCKn means HCK1 and HCK2. (fHCKn = 3.0MHz)

Horizontal Standard Timing

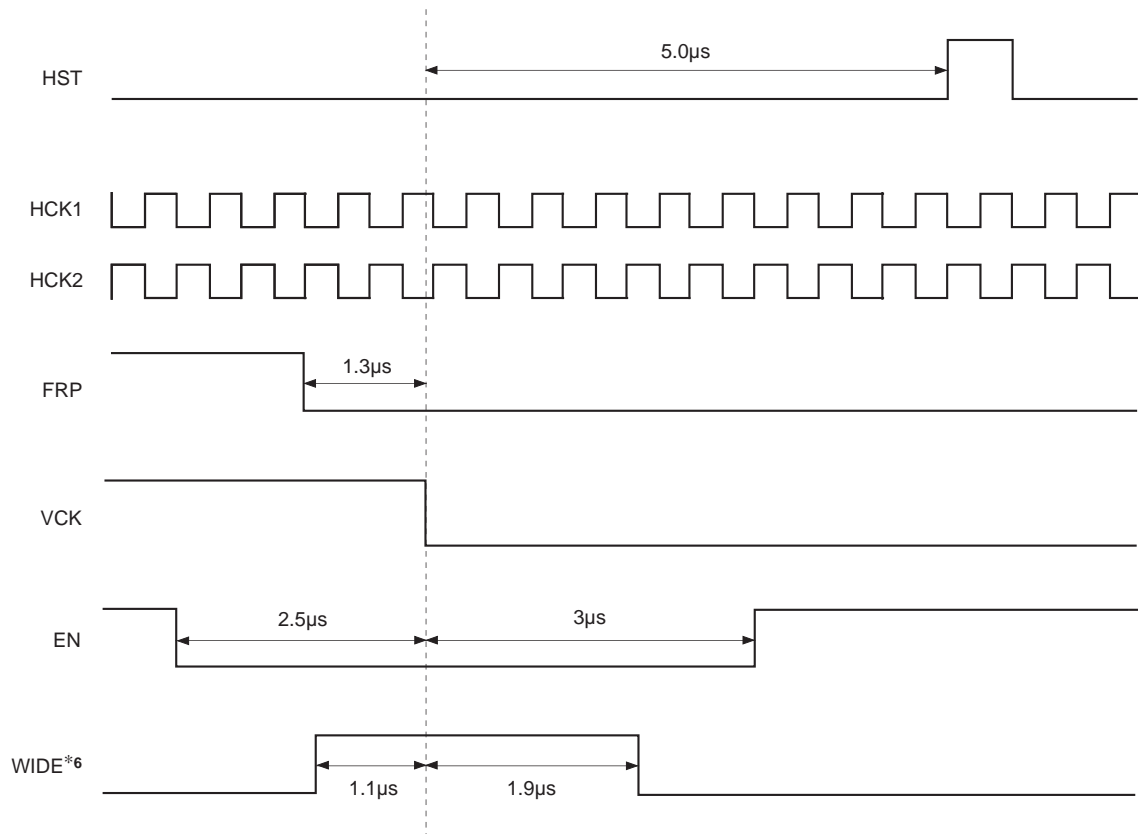

*6 WIDE represents every 1H pulse indicated on the horizontal timing.

<Horizontal Shift Register Driving Waveforms>

Item	Symbol	Waveform	Conditions		
HST	HST rise time	trHst		<ul style="list-style-type: none"> HCKn*5 duty cycle 50% to1Hck = 0ns to2Hck = 0ns 	
	HST fall time	tfHst			
	HST data setup time	tdHst			<ul style="list-style-type: none"> HCKn*5 duty cycle 50% to1Hck = 0ns to2Hck = 0ns
	HST data hold time	thHst			
HCK	HCKn*5 rise time	trHckn		<ul style="list-style-type: none"> HCKn*5 duty cycle 50% to1Hck = 0ns to2Hck = 0ns tdHst = 167ns thHst = 0ns 	
	HCKn*5 fall time	tfHckn			
	HCK1 fall to HCK2 rise time	to1Hck			<ul style="list-style-type: none"> tdHst = 167ns thHst = 0ns
	HCK1 rise to HCK2 fall time	to2Hck			
*6 WIDE	WIDE rise time	trWide			
	WIDE fall time	tfWide			
	WIDE fall to VCK rise/fall time	tdhWide			
	WIDE pulse width	twhWide			

*7 Definitions:

The right-pointing arrow (●→) means +.

The left-pointing arrow (←●) means -.

The black dot at an arrow (●) indicates the start of measurement.

Vertical Standard Timing

NTSC 4:3 (in case of EVEN field)

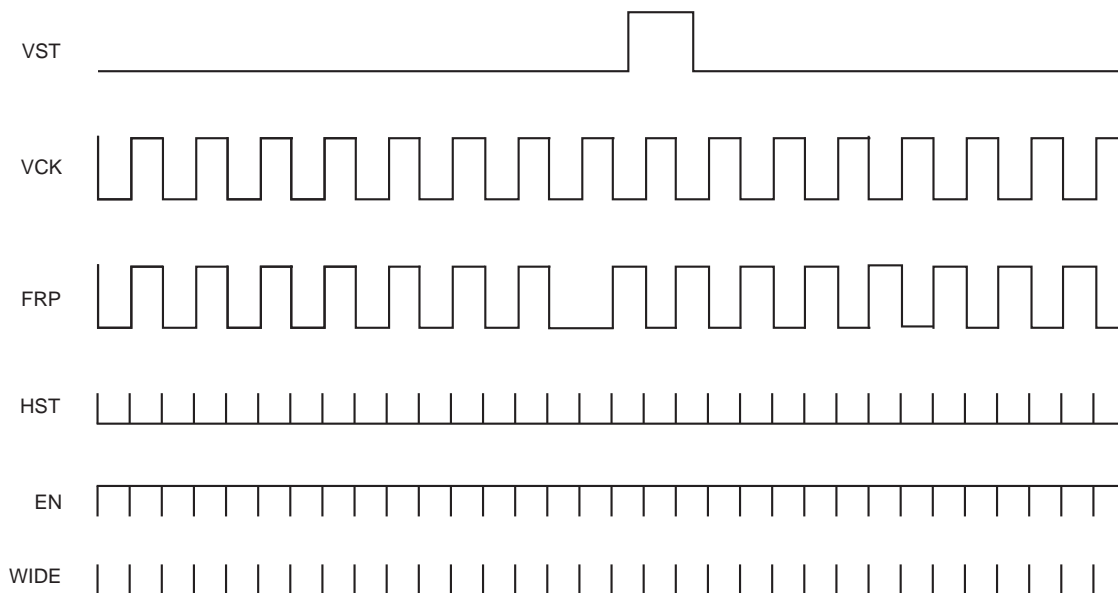

NTSC WIDE (in case of EVEN field)

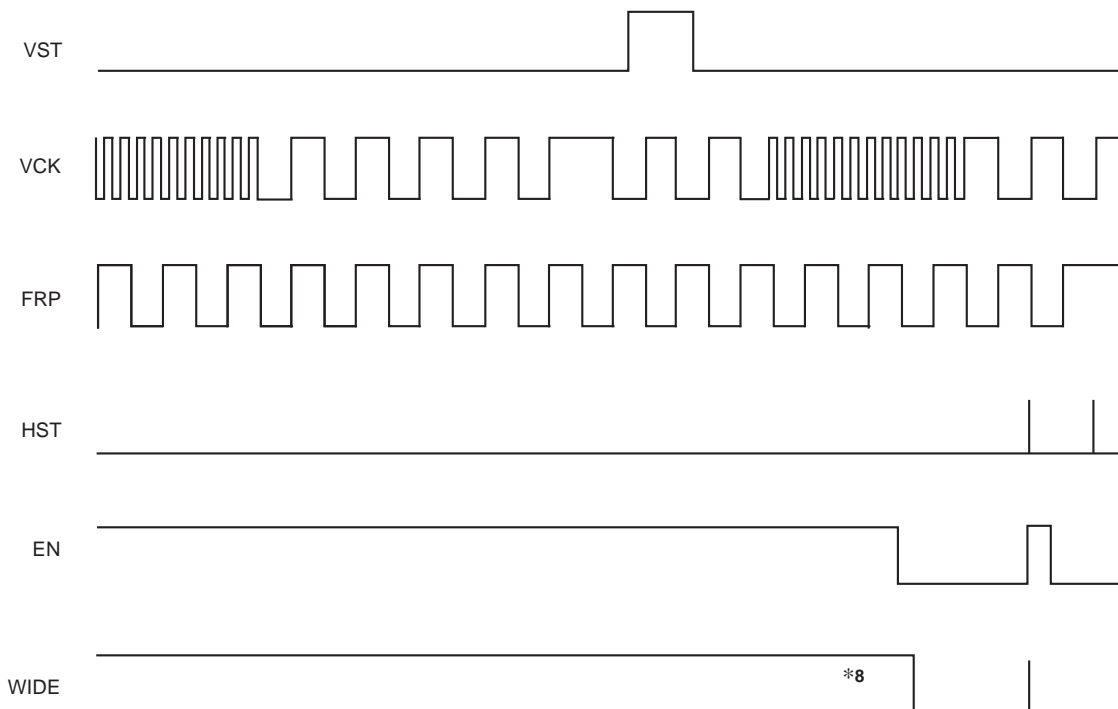

*8 WIDE represents 1F period indicated on the vertical timing.

<Vertical Shift Register Driving Waveforms>

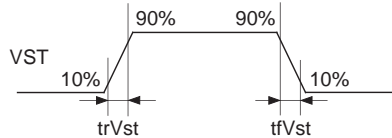
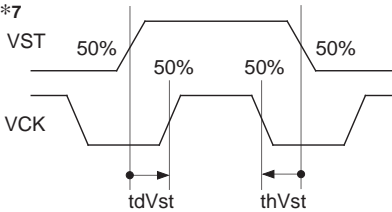
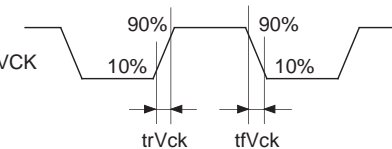
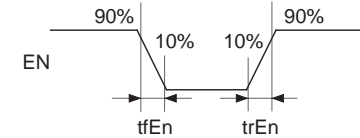
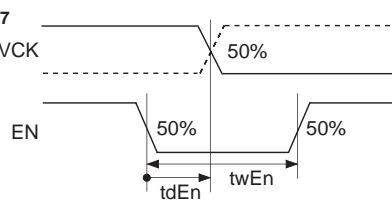
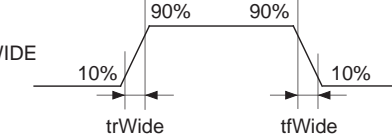
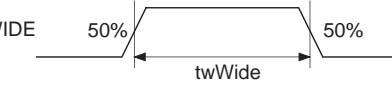
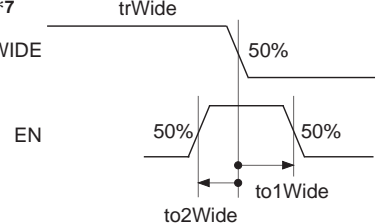
Item	Symbol	Waveform	Conditions	
VST	VST rise time	trVst		<ul style="list-style-type: none"> VCK duty cycle 50% to1Vck = 0ns to2Vck = 0ns
	VST fall time	tfVst		
	VST data setup time	tdVst		<ul style="list-style-type: none"> VCK duty cycle 50% to1Vck = 0ns to2Vck = 0ns
	VST data hold time	thVst		
VCK	VCK rise time	trVck		<ul style="list-style-type: none"> VCK duty cycle 50% to1Vck = 0ns to2Vck = 0ns tdVst = 32μs thVst = -32μs
	VCK fall time	tfVck		
EN	EN rise time	trEn		<ul style="list-style-type: none"> VCK duty cycle 50% to1Vck = 0ns to2Vck = 0ns
	EN fall time	tfEn		
	EN fall to VCK rise/fall time	tdEn		
	EN pulse width	twEn		
*8 WIDE	WIDE rise time	trWide		
	WIDE fall time	tfWide		
	WIDE pulse width	twvWide		
	WIDE fall to EN fall time	tov1Wide		
	EN rise to WIDE fall time	to2Wide		

Electrical Characteristics (Ta = 25°C, HVDD = 12.0V, VVDD = 12.0V, VIH = 3.0V, VREF = 1.5V)

1. Horizontal drivers

Item	Symbol	Min.	Typ.	Max.	Unit	Conditions
HCKn input pin capacitance	CHckn	—	80	95	pF	
HST input pin capacitance	CHst	—	30	45	pF	
Video signal input pin capacitance	Csig	—	270	310	pF	
Psig input pin capacitance (4:3 display)	Cpsig	—	16	20	nF	
Psig input pin capacitance (16:9 display)	Cpsig	—	45	50	nF	
Input pin current HCK1	I Hck1	-900	-300	—	μA	HCK1: actual driving
HCK2	I Hck2	-900	-300	—	μA	HCK2: actual driving
HST	I Hst	-300	-100	—	μA	HST = GND
RGT	I RGT	-150	-50	—	μA	RGT = GND
REF	I REF	-1200	-300	—	μA	REF = VIH/2
Current consumption	(Ta = 25°C)	I H25	—	4.0	4.75	mA
	(Ta = 60°C)	I H60	—	—	6.00	mA

HCKn: HCK1, HCK2 (3.0MHz)

2. Vertical drivers

Item	Symbol	Min.	Typ.	Max.	Unit	Conditions
VCK input pin capacitance	CVck	—	10	15	pF	
VST input pin capacitance	CVst	—	10	15	pF	
Input pin current VCK	I Vck	-150	-50	—	μA	VCK = GND
VST	I Vst	-150	-50	—	μA	VST = GND
EN	I En	-150	-50	—	μA	EN = GND
DWN	I DWN	-150	-50	—	μA	DWN = GND
WIDE	I WIDE	-150	-50	—	μA	WIDE = GND
Current consumption	(Ta = 25°C)	I V25	—	1.0	1.5	mA
	(Ta = 60°C)	I V60	—	—	2.0	mA

3. Total power consumption of the panel

Item	Symbol	Min.	Typ.	Max.	Unit	
Total power consumption of the panel (NTSC)	(Ta = 25°C)	PWR25	—	60	75	mW
	(Ta = 60°C)	PWR60	—	—	96	mW

4. Pin input resistance

Item	Symbol	Min.	Typ.	Max.	Unit
Pin – Vss input resistance	Rin	0.5	1	—	MΩ

Electro-optical Characteristics

(Ta = 25°C, NTSC mode)

Item		Symbol	Measurement method	Min.	Typ.	Max.	Unit	
Contrast ratio	25°C	CR ₂₅	1	100	200	—	—	
	60°C	CR ₆₀		100	200	—		
Optical transmittance		T	2	7.7	8.2	—	%	
Chromaticity	R	X	R _x	3	0.595	0.625	0.655	CIE standards
		Y	R _y		0.310	0.340	0.370	
	G	X	G _x		0.245	0.275	0.305	
		Y	G _y		0.580	0.610	0.640	
	B	X	B _x		0.120	0.150	0.180	
		Y	B _y		0.090	0.120	0.150	
V-T characteristics	V ₉₀	25°C	V ₉₀₋₂₅	4	1.30	1.50	1.70	V
		60°C	V ₉₀₋₆₀		1.30	1.50	1.70	
	V ₅₀	25°C	V ₅₀₋₂₅		1.70	1.90	2.10	
		60°C	V ₅₀₋₆₀		1.70	1.90	2.10	
	V ₁₀	25°C	V ₁₀₋₂₅		2.20	2.40	2.60	
		60°C	V ₁₀₋₆₀		2.20	2.40	2.60	
Half tone color reproduction range		R – G	V _{50RG}	5	-0.050	-0.080	-0.110	V
		B – G	V _{50BG}		0.000	0.030	0.050	
Response time	ON time	0°C	ton0	6	—	40	55	ms
		25°C	ton25		—	15	25	
	OFF time	0°C	toff0		—	140	180	
		25°C	toff25		—	50	75	
Flicker		60°C	F	7	—	-60	-30	dB
Image retention time		1 min.	YT1	8	—	—	10	s
Viewing angle range		CR ≥ 10	θT	9	35	45	—	Degree (°)
			θB		50	60		
			θL		45	55		
			θR		45	55		
Surface reflection ratio		θ = 0°	R _f	10	—	0.9	1.5	%
Cross talk		25°C	CTK	11	—	—	1.5	%

<Electro-optical Characteristics Measurement>

Basic measurement conditions

- (1) Driving voltage
 $HV_{DD} = 12.0V$, $VV_{DD} = 12.0V$, $VIH = 3.0V$, $VREF = 1.5V$
 $VVC = 5.5V$, $VCOM = 5.2V$, $Vpsig = 5.5 \pm 2.5V$
- (2) Measurement temperature
 25°C unless otherwise specified.
- (3) Measurement point
 One point in the center of the screen unless otherwise specified.
- (4) Measurement systems
 Three types of measurement systems are used as shown below.
- (5) R, G and B input signal voltage V_{sig}
 $V_{sig} = 5.5 \pm V_{AC} [V]$ (V_{AC} : signal amplitude)

* Measurement system I

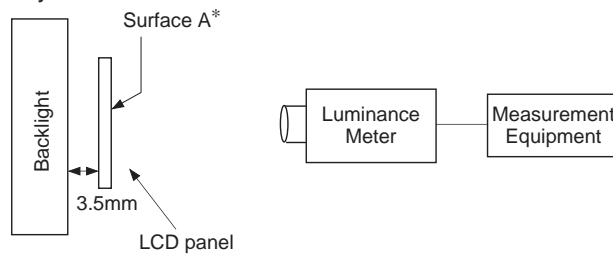

* Measurement system II

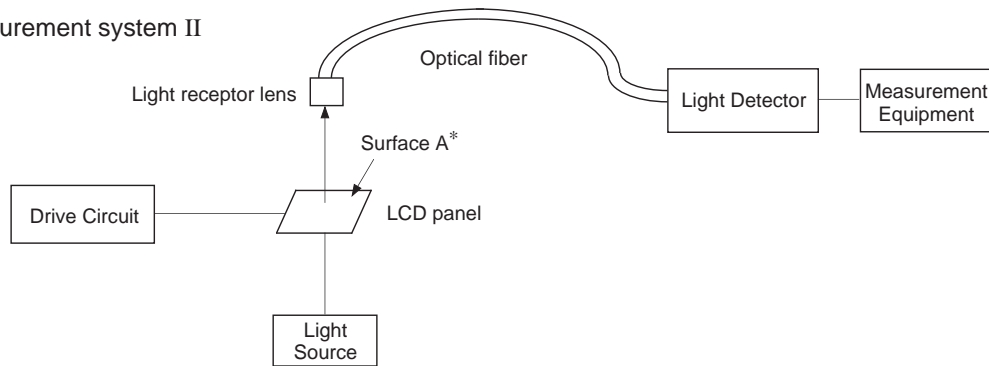

* Measurement system III

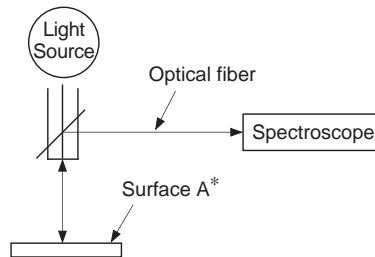

* Surface A: See the Package Outline.

1. Contrast Ratio

Contrast ratio (CR) is given by the following formula.

$$CR = L \text{ (White)} / L \text{ (Black)}$$

L (White): Surface luminance of the TFT-LCD panel at the input signal amplitude $V_{AC} = 0.5V$.

L (Black): Surface luminance of the panel at $V_{AC} = 4.0V$.

Both luminosities are measured by System I.

2. Optical Transmittance

Optical transmittance (T) is given by the following formula.

$$T = L \text{ (White)}/\text{Luminance of Backlight} \times 100 \text{ [\%]}$$

L (White) is the same expression as defined in the "Contrast Ratio" section.

Optical transmittance is measured by System I.

3. Chromaticity

Chromaticity of the panels is measured by System I. Raster modes of each color are defined by the representations at the input signal amplitude conditions shown in the table below. System I uses x and y of the CIE standards as the chromaticity here.

		Signal amplitudes (V _{AC}) supplied to each input		
		R input	G input	B input
Raster	R	0.5	4.0	4.0
	G	4.0	0.5	4.0
	B	4.0	4.0	0.5
	W	0.0	0.0	0.0

(Unit: V)

4. V-T Characteristics

V-T characteristics, or the relationship between signal amplitude and the transmittance of the panel, are measured by System II by inputting the same signal amplitude V_{AC} to each input pin. V₉₀, V₅₀, and V₁₀ correspond to the voltages which define 90%, 50%, and 10% of transmittance respectively.

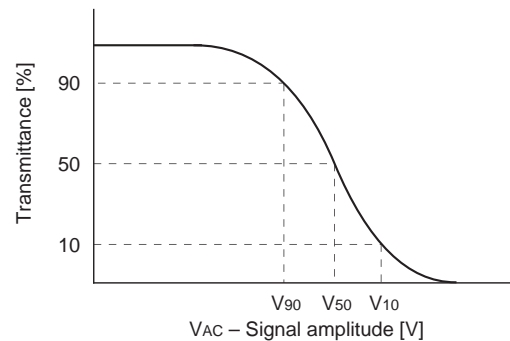

5. Half Tone Color Reproduction Range

The half tone color reproduction range of LCD panels is characterized by the differences between the V-T characteristics of R, G and B. The differences of these V-T characteristics are measured by System II. System II defines signal voltages of each R, G and B raster mode which correspond to 50% of transmittance, V_{50R}, V_{50G} and V_{50B}, respectively. V_{50RG} and V_{50BG}, that is to say the differences between V_{50R} and V_{50G} and between V_{50B} and V_{50G}, are given by the following formulas respectively.

$$V_{50RG} = V_{50R} - V_{50G}$$

$$V_{50BG} = V_{50B} - V_{50G}$$

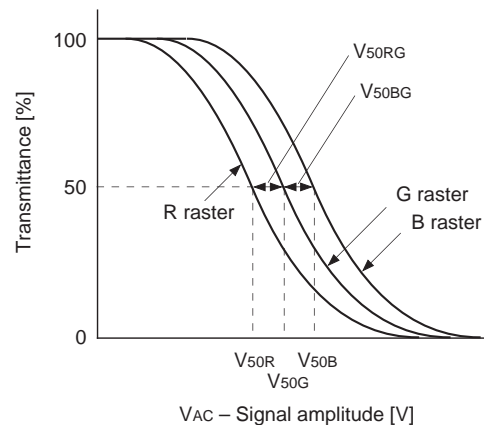

6. Response Time

Response times t_{on} and t_{off} are measured by System II by applying the input signal voltages in the figure to the right to each input pin. These times are defined by the following formulas.

$$t_{on} = t_1 - t_{ON}$$

$$t_{off} = t_2 - t_{OFF}$$

t_1 : time which gives 10% transmittance of the panel.

t_2 : time which gives 90% transmittance of the panel.

The relationships between t_1 , t_2 , t_{ON} and t_{OFF} are shown in the figure to the right.

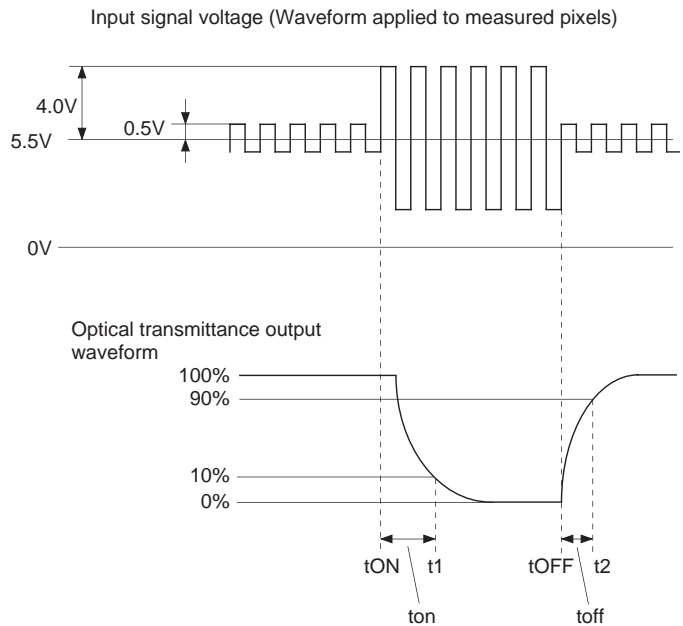

7. Flicker

Flicker (F) is given by the following formula. DC and AC components (NTSC: 30Hz, rms; PAL: 25Hz, rms) of the panel output signal for gray raster* mode are measured by a DC voltmeter and a spectrum analyzer in System II.

$$F \text{ (dB)} = 20 \log \{ \text{AC component} / \text{DC component} \}$$

* R, G, B input signal voltage for gray raster mode is given by $V_{sig} = 5.5 \pm V_{50}$ (V) where: V_{50} is the signal amplitude which gives 50% of transmittance in V-T curve.

8. Image Retention Time

Image retention time is given by the following procedures.

Apply the monoscope pattern* to the LCD panel for 1 minute and then change to a gray scale signal ($V_{sig} = 5.5 \pm V_{AC}$ (V); $V_{AC} = 3$ to 4V). Judging by sight at the V_{AC} that holds the maximum image retention, measure the time for the residual image to disappear.

* Monoscope pattern input conditions
 $V_{sig} = 5.5 \pm 4.0$ or 5.5 ± 2.0 [V]
 (shown in the figure to the right)
 $V_{com} = 5.20V$

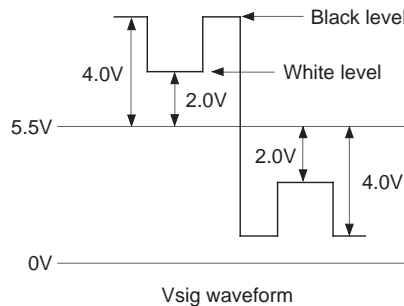

9. Definition of Viewing Angle Range

Viewing angle range is measured by System I. The contrast ratio (CR) is measured at the angles defined in the figure to the right and the range where CR ≥ 10 is taken as the viewing angle range.

Measure with surface A* facing upwards.

* Surface A: See the Package Outline.

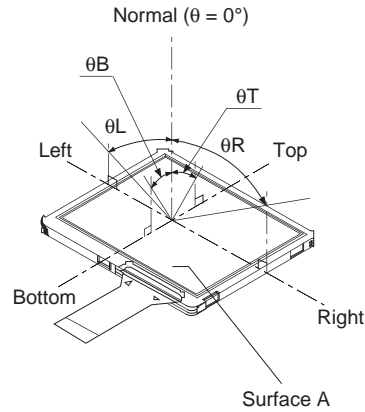

10. Surface Reflection Ratio

Surface reflection ratio (Rf) is given by the following formula.

$$Rf = \text{Reflected optical luminance of the panel surface A}^* / \text{Reflected optical luminance of Al (wafer)} \times 100 [\%]$$

The incident and reflected angles of light are both 0°.

Both luminosities are measured by System III.

* Surface A: See the Package Outline.

11. Cross Talk

Cross talk is determined by the luminance differences between adjacent areas represented by Wi' and Wi (i = 1 to 4) around the black window (Vsig = 4.0V/1V).

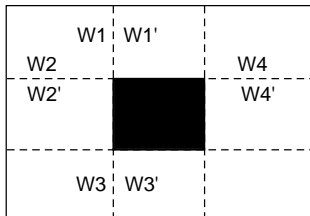

$$\text{Cross talk value CTK} = \left| \frac{W_i' - W_i}{W_i} \right| \times 100 [\%]$$

12. Measurement Backlight Specifications

Optical characteristics

Item	Standard	Unit	Remarks
Average luminance of effective illuminating surface	2,700 ± 300	cd/m ²	Ta = 25 ± 2°C, at dimmer = max.
Color temperature (reference value)	8,800	K	Ta = 25 ± 2°C, at dimmer = max.
Chromaticity coordinates	x: 0.285 ± 0.01 y: 0.303 ± 0.01		

Description of Operation

1. Color Coding

The color filters are coded in a delta arrangement. The shaded area is used for the dark border around the display.

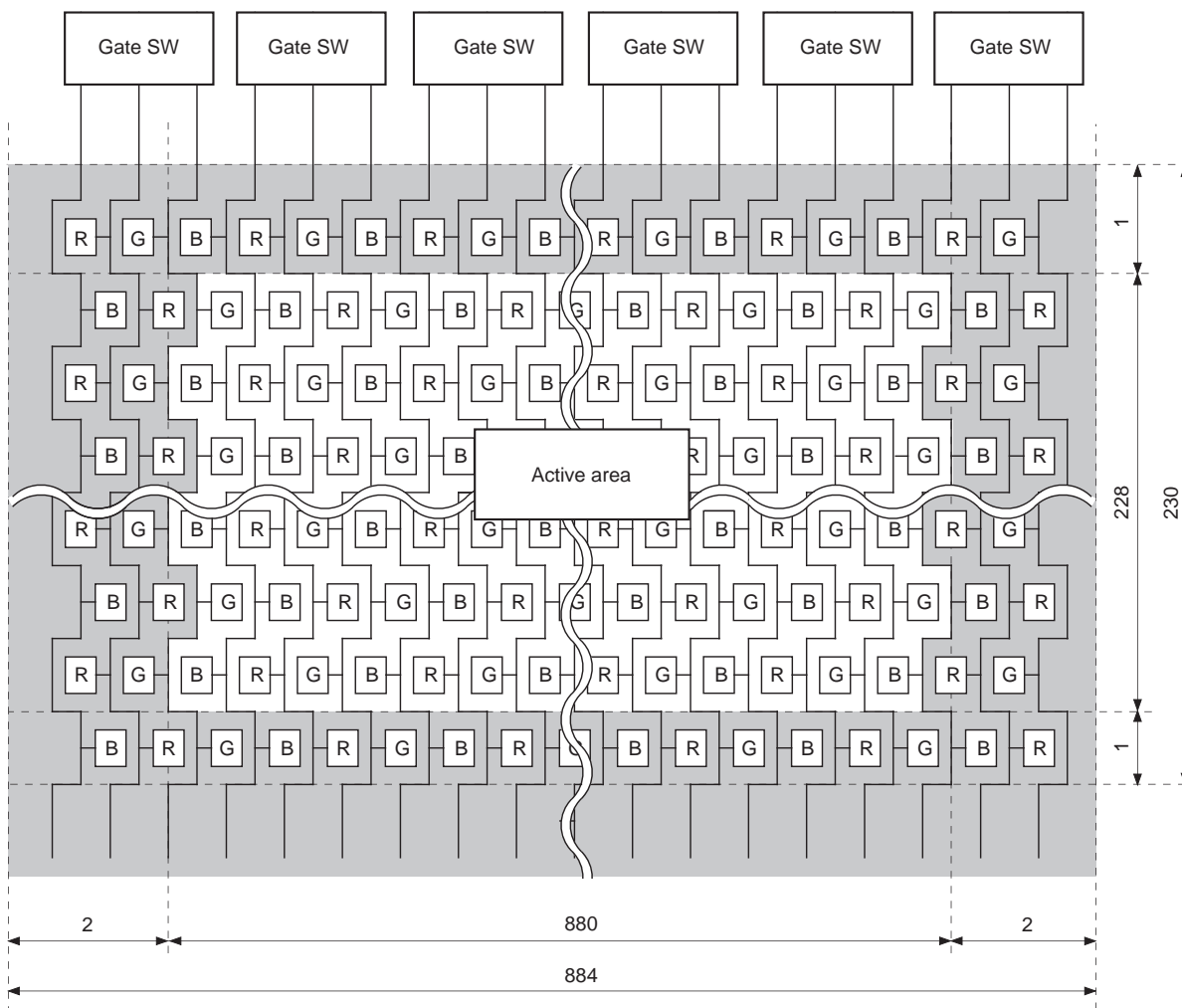

2. Description of LCD Panel Operations

- A vertical driver, which consists of vertical shift registers, enable-gates and buffers, applies a selected pulse to each of 228 line electrodes sequentially one line electrode at a time in a single horizontal scanning period.
- The selected pulse is output when the enable pin goes to high level. PAL signal pulse elimination display and 16:9 mode pulse elimination display are possible by using the enable pin and simultaneously controlling VCK.
- A horizontal driver, which consists of horizontal shift registers, gates and CMOS sample-and-hold circuitry, applies selected pulses to each of 880 signal electrodes sequentially in a single horizontal scanning period. These pulses are used to supply the sampled video signal to the row signal lines.
- The scanning direction of the horizontal shift registers can be switched with the RGT pin. The scanning direction is left to right (right scan) for RGT pin at high level (2.6 to 5.5V), and right to left (left scan) for RGT pin at low level (0V). In addition, the scanning direction of the vertical shift registers can be switched with the DWN pin. The scanning direction is top to bottom for DWN pin at high level (2.6 to 5.5V), and bottom to top for DWN pin at low level (0V). (These scanning directions are from a front view.)
- The vertical and horizontal drivers address one pixel, and then thin film transistors (TFTs; two TFTs for one pixel) turn on to apply a video signal to the pixel. The same procedures lead to the entire 228 × 880 pixels to display a picture in a single vertical scanning period.
- Pixel dots are arranged in a delta arrangement, where sets of RGB pixels are positioned shifted by 1.5 dots against adjacent horizontal lines. The horizontal driver output pulse must be shifted by 1.5 dots for each horizontal line against the horizontal sync signal to apply a video signal to each pixel properly.
- The video signal should be input with the polarity-inverted every horizontal cycle.
- The relationships between the vertical shift register start pulse VST and the vertical display period, and between the horizontal shift register start pulse HST and the horizontal display period are shown below for top to bottom and left to right scan.

(1) Vertical display period (DWN: high level)

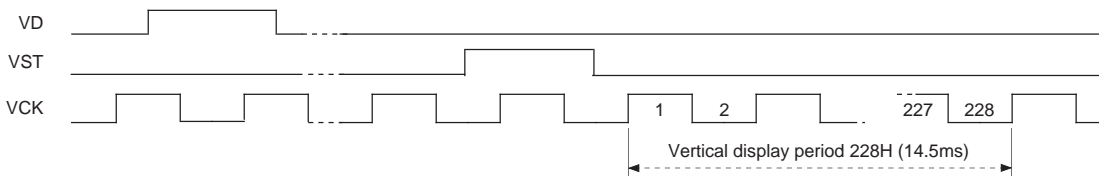

(2) Vertical display period (DWN: low level)

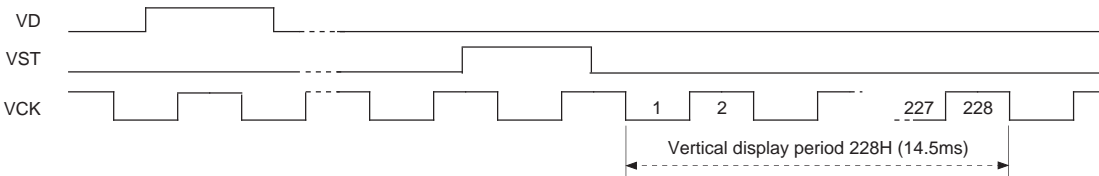

(3) Horizontal display period (RGT: high level)

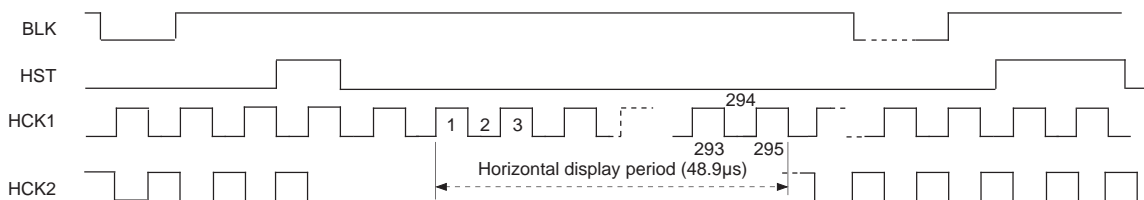

3. RGB Simultaneous Sampling

The horizontal driver samples R, G and B video signal simultaneously, which requires phase matching between the R, G and B signals to prevent the horizontal resolution from deteriorating. Thus phase matching by an external signal delay circuit is needed before applying the video signal to the LCD panel.

Two methods are applied for the delaying procedure: Sample-and-hold and Delay circuits. These two block diagrams are as follows.

The ACX302AK has a right/left inversion function. The following phase relationship diagram indicates the phase setting for right scan (RGT = high level). For left scan (RGT = low level), the phase setting should be inverted for the B and G signals.

(1) Sample-and-hold (right scan)

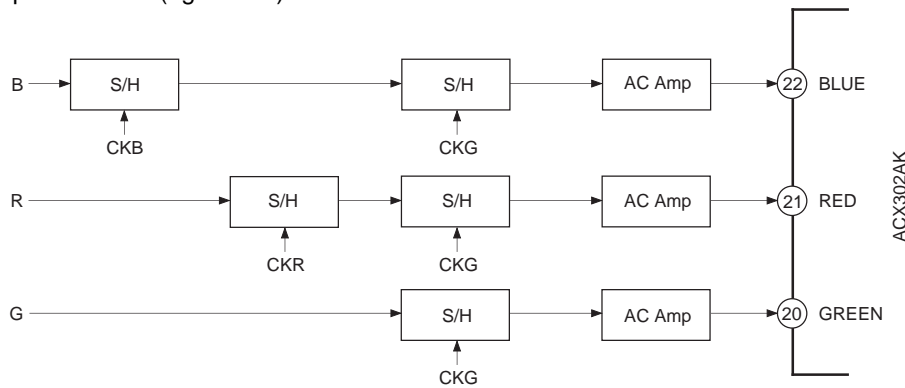

<Phase relationships of delaying sample-and-hold pulses> (right scan)

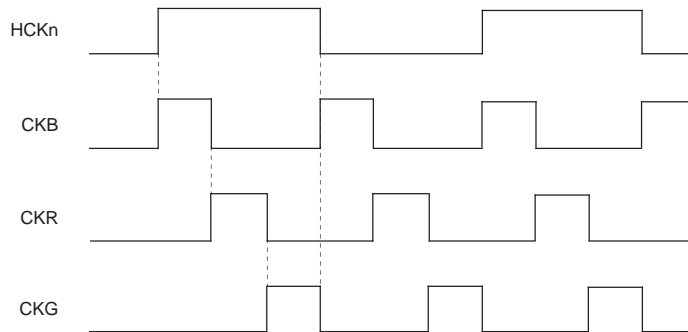

(2) Delay element (right scan)

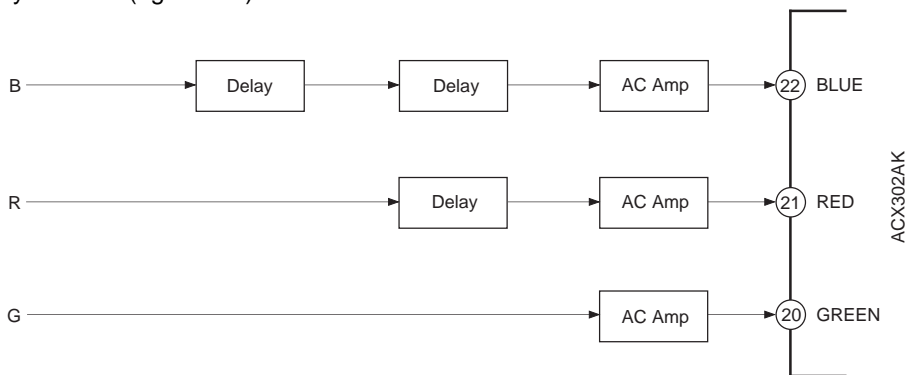

System Configuration

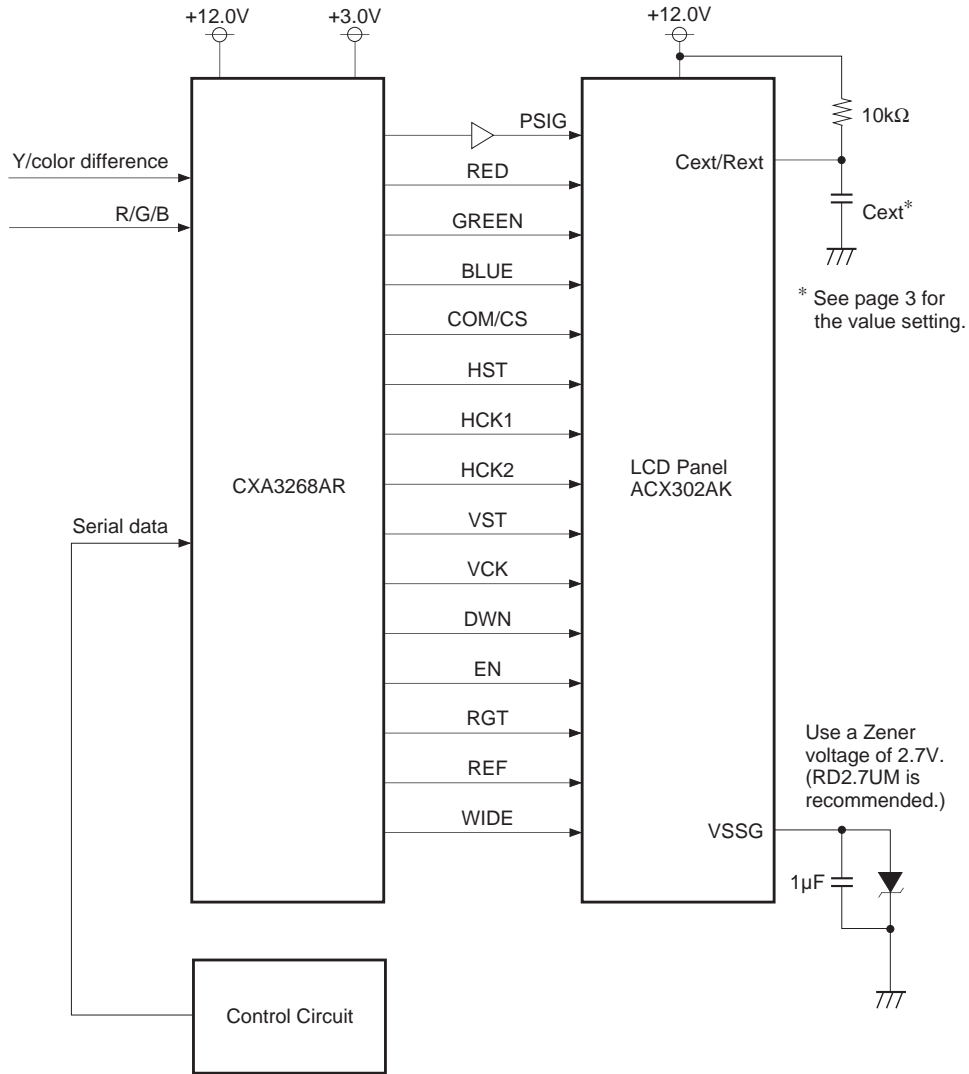

Notes on Handling**(1) Static charge prevention**

Be sure to take the following protective measures. TFT-LCD panels are easily damaged by static charges.

- a) Use non-chargeable gloves, or simply use bare hands.
- b) Use an earth-band when handling.
- c) Do not touch any electrodes of a panel.
- d) Wear non-chargeable clothes and conductive shoes.
- e) Install grounded conductive mats on the working floor and working table.
- f) Keep panels away from any charged materials.
- g) Use ionized air to discharge the panels.

(2) Protection from dust and dirt

- a) Operate in a clean environment.
- b) Do not touch the polarizer surface. The surface is easily scratched. When cleaning, use a clean-room wiper with isopropyl alcohol. Be careful not to leave stains on the surface.
- c) Use ionized air to blow dust off the panel.

(3) Other handling precautions

- a) Do not twist or bend the flexible PC board especially at the connecting region because the board is easily deformed.
- b) Do not drop the panel.
- c) Do not twist or bend the panel or panel frame.
- d) Keep the panel away from heat sources.
- e) Do not dampen the panel with water or other solvents.
- f) Avoid storing or using the panel at high temperatures or high humidity, as this may result in panel damage.

Package Outline Unit: mm

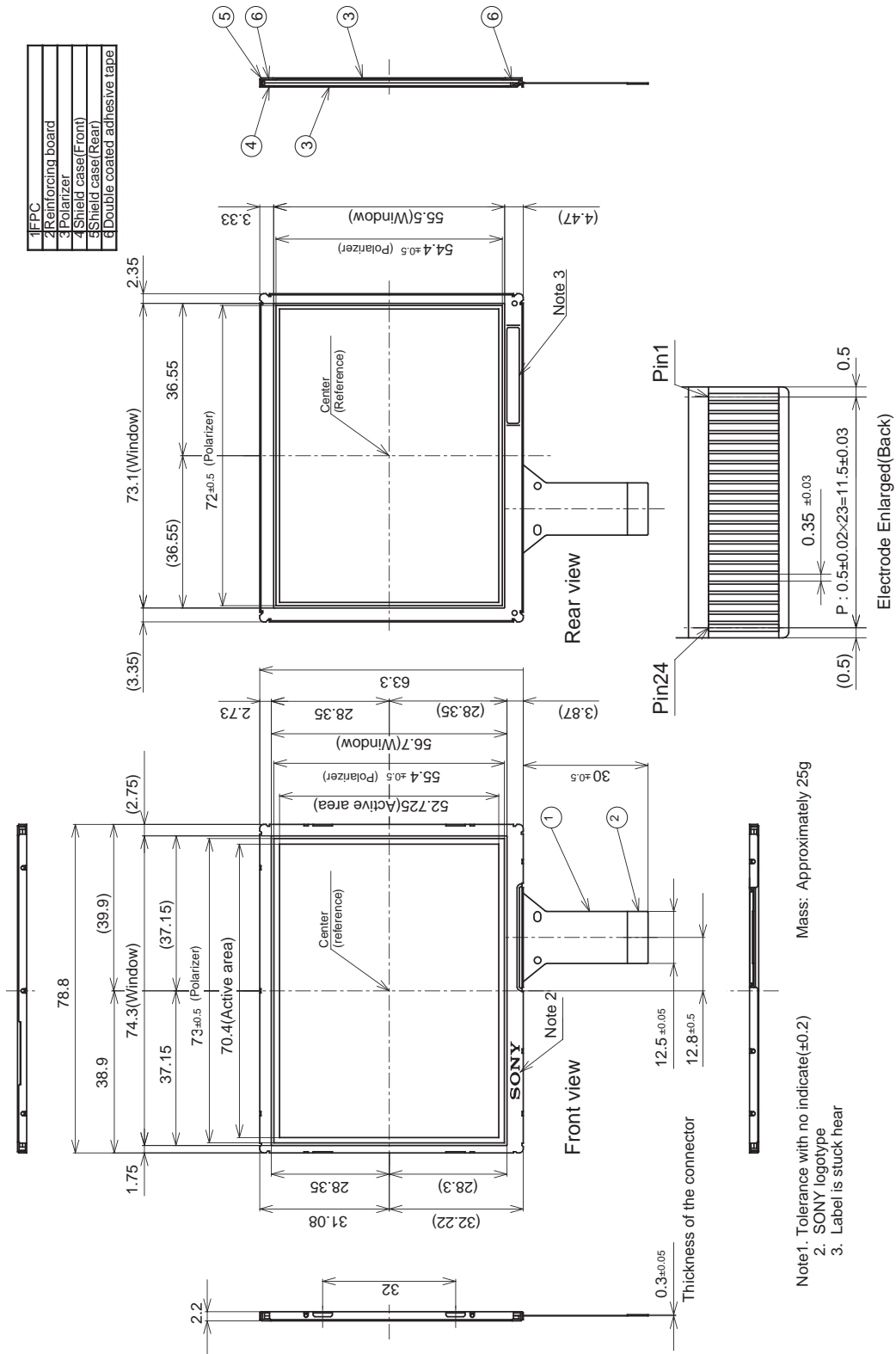

Note 1. Tolerance with no indicate(±0.2)
 2. SONY logotype
 3. Label is stuck hear

Mass: Approximately 25g