

Low-temperature Polysilicon TFT LCDs
Evolving Towards Higher Picture Quality Picture and Lower Power
200K-dot Transmissive Color LCDs in 2.0, 2.5, 3.5-inch Sizes

ACX300AK, ACX301AK, ACX302AK

The ACX300 Series (the ACX300AK, ACX301AK, and ACX302AK) are even more highly evolved low-temperature polysilicon TFT LCD panels than the earlier models that have been used as small-sized monitors that meet the needs for high picture quality in AV equipment such as digital still cameras and digital video cameras. As such, these new products can truly be called the next generation products.

These panels, which take full advantage of the latest low-temperature polysilicon TFT process technology and polysilicon TFT circuit technology, can achieve reduced power consumption, higher definition, and increased transmittance at the same time, and promise radically increased competitiveness for products that incorporate them.

- Number of active dots: 200K (delta arrangement)
- Horizontal resolution: 440 TV lines
- Low power consumption
- Supports 3-V drive signals
- Supports NTSC/PAL 16:9 mode
- Up/down and/or right/left inversion functions
- AG (anti-glare) coatings
- Thin form-factor panel using 0.7-mm glass

Industry's Highest Resolution Achieved by Taking Maximum Advantage of the Low-temperature Polysilicon TFT

By taking advantage of not only the high-mobility transistor performance, which is a feature of the low-temperature polysilicon TFT, but also high aperture ratio pixel design, Sony succeeded in increasing the horizontal resolution by 20% over earlier Sony models. The ACX300 Series products take full advantage of Sony's low-temperature polysilicon TFT technology to achieve the high transmittance of current 100K to 120K-dot class products (increased by 15% over 2.5-inch Sony products) despite being 200K-dot high definition products. This improved definition provides smooth, fine-grained high-quality picture without apparent dots.

Low-Power Technology

To respond to the trend towards lower power in digital video cameras and other AV equipment, the ACX300 Series adopts a precise power control system for each drive circuit block in the panel, and also adopts a 12-V supply voltage. This reduces the panel power consumption by 60% over earlier models, and achieves the low power consumption of 50 mW (typical) (60 mW for the ACX302) when 12-V drive is used. Since all timing signal inputs accept 3-V level signals, the LCD system power can be reduced in products that include these panels. Furthermore, since the drive system uses the Sony CXA3268R low power highly integrated IC, which integrates the precharge signal (Psig) and other signals that were previously generated as external devices, the number of external components in the LCD system can be reduced.

Lineup Supports a Wide Range of Applications

— From digital still cameras to small TV sets —

All of the unique TFT process and high-quality technology developed by Sony, the industry leader in low-temperature polysilicon TFT panel development, is applied in the ACX300 Series small-sized LCD panels. The product line includes three sizes: 2 inches (the ACX301), 2.5 inches (the ACX300) and 3.5 inches (the ACX302), and thus includes a screen size optimal for almost any product, from digital still cameras to video cameras and small TV sets. Furthermore, since all models have the same system structure, it is extremely easy to create a series of related application products.

High-Quality Panels Supplied from a New Factory

The ACX300 Series panels are manufactured by ST LCD Corporation, which is a joint venture between Sony Corporation and TOYODA AUTOMATIC LOOM WORKS, LTD. and is located in Aichi prefecture. These products are manufactured on a fully automatic line equipped with the world's largest and highest performance clean room. Low-temperature polysilicon TFTs are formed on the world's largest glass substrates in this high-quality line. Even more than before, Sony is the leading source for high-quality panels.

V O I C E

ST LCD Corporation has begun LCD panel production now. Moreover, they will be producing a full product line of panels from an early date. Pictures that are faithfully reproduced down to the finest detail by advanced low-temperature polysilicon TFT technology will become standard in small-sized LCD monitors from now on. I strongly recommend that you try these products.



New
Products

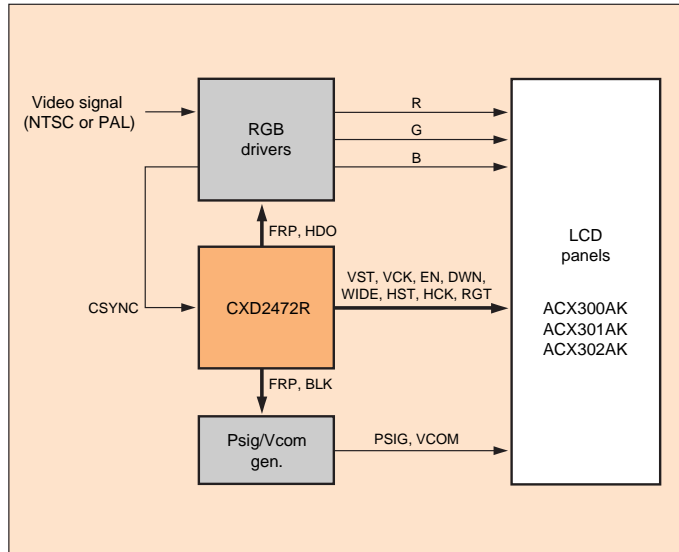

■ Figure 1 ACX300AK/301AK/302AK Drive System Block Diagram (Two-chip Structure)

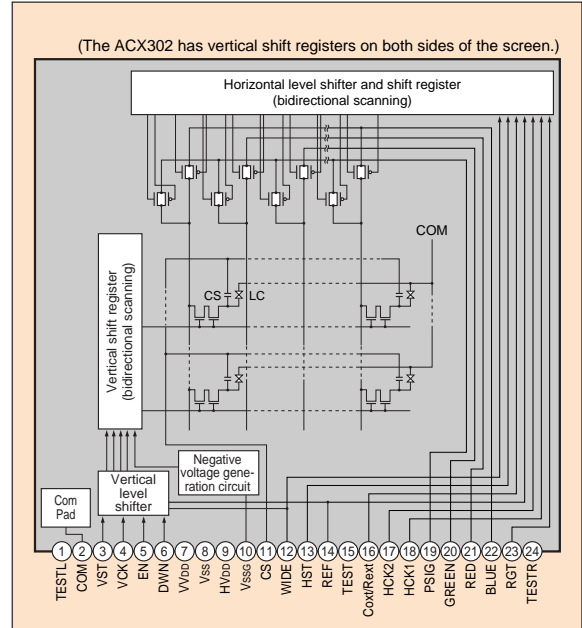

■ Figure 3 ACX300AK/301AK/302AK Block Diagram

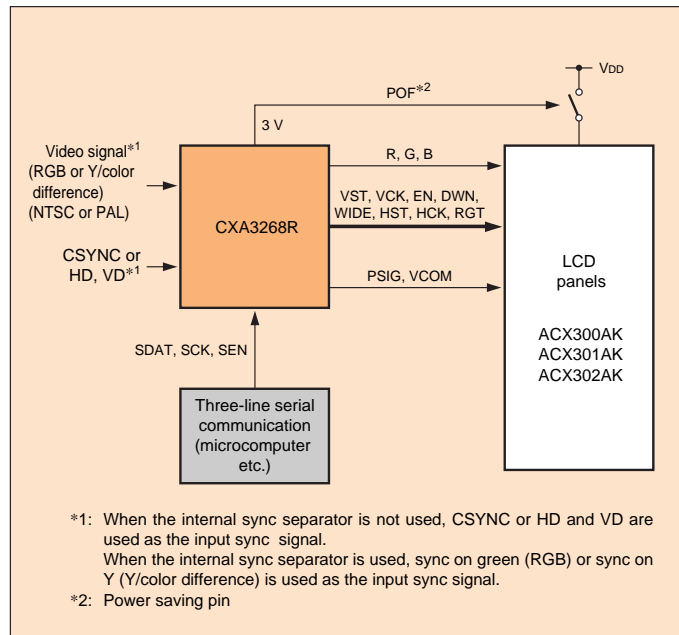

*1: When the internal sync separator is not used, CSYNC or HD and VD are used as the input sync signal.
When the internal sync separator is used, sync on green (RGB) or sync on Y (Y/color difference) is used as the input sync signal.
*2: Power saving pin

■ Figure 2 ACX300AK/301AK/302AK Drive System Block Diagram (Single-chip Structure)

■ Table 1 Panel Specifications Comparison

	ACX300AK	ACX301AK	ACX302AK
Screen size (mm ²)	49.94 × 37.34 (6.24 cm diagonal)	40.48 × 30.55 (5.07 cm diagonal)	70.4 × 52.725 (8.80 cm diagonal)
Package dimensions (mm ²)	57.8 × 47.85	49.8 × 44.2	78.8 × 63.3
Total number of dots	880 × 228 = 200,640		
Dot pitch (μm × μm)	56.75 × 163.75	46 × 134	80 × 231.25
Optical transmittance (%)	7.0	6.0	8.5
Supply voltage (V)	11.4 to 14.0		
Power consumption* (mW)	50		60

*: Supply voltage: 12 V