

Dual Baud Rate Generator Programmable Divider

FEATURES

- On chip crystal oscillator or external frequency input
- Single +5v power supply
- Choice of 2 x 16 output frequencies
- 16 asynchronous/synchronous baud rates
- Direct UART/USRT/ASTRO/USYNRT compatibility
- Full duplex communication capability
- High frequency reference output*
- Re-programmable ROM via CLASP® technology allows generation of other frequencies
- TTL, MOS compatibility
- Compatible with COM 5016/COM 5036

PIN CONFIGURATION

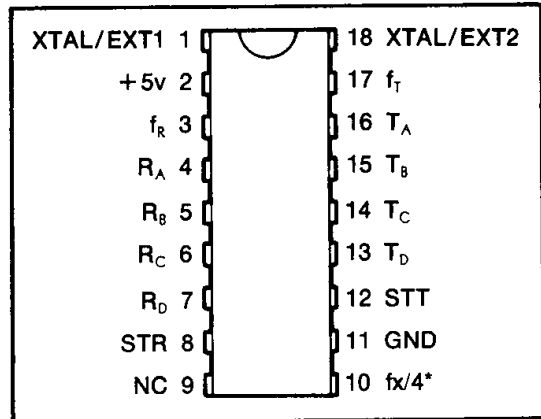

BLOCK DIAGRAM

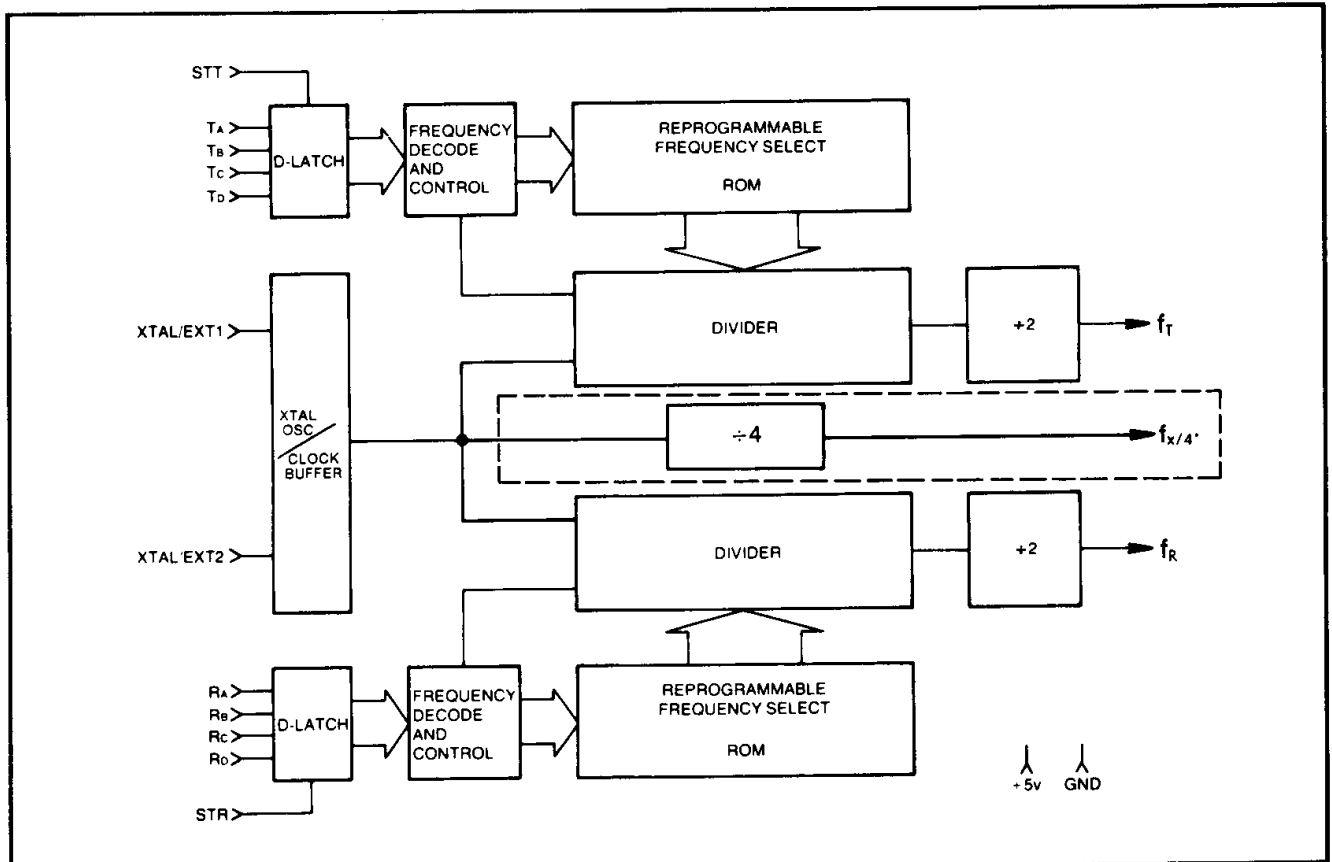

*COM 8136/T only

General Description

The Standard Microsystem's COM 8116/COM 8136 is an enhanced version of the COM 5016/COM 5036 Dual Baud Rate Generator. It is fabricated using SMC's patented COPLAMOS® and CLASP® technologies and employs depletion mode loads, allowing operation from a single +5v supply.

The standard COM 8116/COM 8136 is specifically dedicated to generating the full spectrum of 16 asynchronous/synchronous data communication frequencies for 16X UART/USRT devices. A large number of the frequencies available are also useful for 1X and 32X ASTRO/USYNT devices.

The COM 8116/COM 8136 features an internal crystal oscillator which may be used to provide the master reference frequency. Alternatively, an external reference may be supplied by applying complementary TTL level signals to pins 1 and 18. Parts suitable for use only with an external TTL reference are marked COM 8116T/COM 8136T. TTL outputs used to drive the COM 8116/COM 8136 or COM 8116T/COM 8136T XTAL/EXT inputs should not be used to drive

other TTL inputs, as noise immunity may be compromised due to excessive loading.

The output of the oscillator/buffer is applied to the dividers for generation of the output frequencies f_T , f_R . The dividers are capable of dividing by any integer from 6 to $2^{10} + 1$, inclusive. If the divisor is even, the output will be square; otherwise the output will be high longer than it is low by one f_x clock period.

The reference frequency (f_x) is used to provide a high frequency output at $f_x/4$ on the COM 8136/T.

Each of the two divisor ROMs contains 16 divisors, each 19 bits wide, and is fabricated using SMC's unique CLASP® technology allowing up to 32 different divisors on custom parts. This process permits reduction of turn-around time for ROM patterns. Each group of four divisor select bits is held in an externally strobed data latch. The strobe input is level sensitive: while the strobe is high, data is passed directly through to the ROM. Initiation of a new frequency is effected within 3.5 μ s of a change in any of the four divisor select bits (strobe activity is not required). The divisor select inputs have pull-up resistors; the strobe inputs do not.

Description of Pin Functions

Pin No.	Symbol	Name	Function
1	XTAL/EXT1	Crystal or External Input 1	This input is either one pin of the crystal package or one polarity of the external input.
2	V_{CC}	Power Supply	+5 volt supply
3	f_R	Receiver Output Frequency	This output runs at a frequency selected by the Receiver divisor select data bits.
4-7	R_A, R_B, R_C, R_D	Receiver-Divisor Select Data Bits	The logic level on these inputs, as shown in Table 1, selects the receiver output frequency, f_R .
8	STR	Strobe-Receiver	A high level input strobe loads the receiver data (R_A, R_B, R_C, R_D) into the receiver divisor select register. This input may be strobed or hard-wired to a high level.
9	NC	No Connection	
10	$f_x/4^*$	$f_x/4$	$1/4$ crystal/clock frequency reference output.
11	GND	Ground	
12	STT	Strobe-Transmitter	A high level input strobe loads the transmitter data (T_A, T_B, T_C, T_D) into the transmitter divisor select register. This input may be strobed or hard-wired to a high level.
13-16	T_D, T_C, T_B, T_A	Transmitter-Divisor Select Data Bits	The logic level on these inputs, as shown in Table 1, selects the transmitter output frequency, f_T .
17	f_T	Transmitter Output Frequency	This output runs at a frequency selected by the Transmitter divisor select data bits.
18	XTAL/EXT2	Crystal or External Input 2	This input is either the other pin of the crystal package or the other polarity of the external input.

*COM 8136/T only

For electrical characteristics, see page 281.