

# MEMS Variable Optical Attenuators

## MATT Series

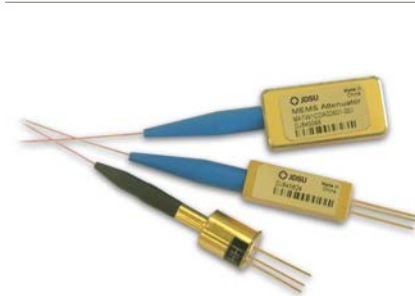

### Key Features



- Low polarization dependence
- Insensitive to vibration and electrostatic discharge (ESD)
- Extremely low wavelength dependence over C and/or L bands
- Multiple devices easily packaged into common housing
- Available in both normally open and normally closed states
- Available in three different packages

### Applications

- Power equalization in multi-channel, optically amplified networks
- Gain-tilt control in erbium doped fiber amplifiers (EDFAs)
- Power control into narrowband wavelength division multiplexers (WDMs) and configurable networks
- Photoreceiver trimming
- Receiver protection/switch during transmitter turn-ons

### Compliance

- Telcordia 1209 and 1221
- Passed monitored MIL-STD 883 (GR-1221) conditions vibration test (insensitive to 20 g peak acceleration)
- Passed MIL-STD 883 (500 V) ESD test conditions

The JDSU Agile Optical Components family includes modulators, switches, attenuators and tunable filters. These products provide the basis for spectrally efficient DWDM transmission utilizing dispersion tolerant modulation, channel monitoring, wavelength switching, remote power control and dynamic channel selection. They support a wide range of flexible functionalities at lower operational expenses for the Agile Optical Network. In addition, we have a complete line of tunable lasers assemblies and sub-assemblies in our Agile Transmission Module family.

JDSU microelectromechanical systems variable optical attenuators (MATT) focus on key network optical power management applications. JDSU offers MEMS attenuators in normally open and normally closed states. The MATT series attenuators fully comply with Telcordia 1221 reliability program. Key features include a small size, low wavelength dependent loss (WDL), and high reliability. JDSU provides three different package options: DIL MATT, TO MATT, and Micro MATT.

The MEMS attenuator design achieves highly repeatable optical attenuation over C and/or L bands through a thermally-actuated reflective vane that intercepts light. Applied power/voltage actuates the vane and translates in and out of the light beam. In a closed loop mode with constantly applied electrical power/voltage, the MEMS attenuator achieves excellent performance over a wide temperature range and in a variety of environmental conditions. DIL MATTs include an internal temperature sensor which can be used to compensate the temperature dependent performance for accurate open loop operation.

## 2

## Dimensions Diagram: DIL MATT

(Specifications in mm unless otherwise noted.)

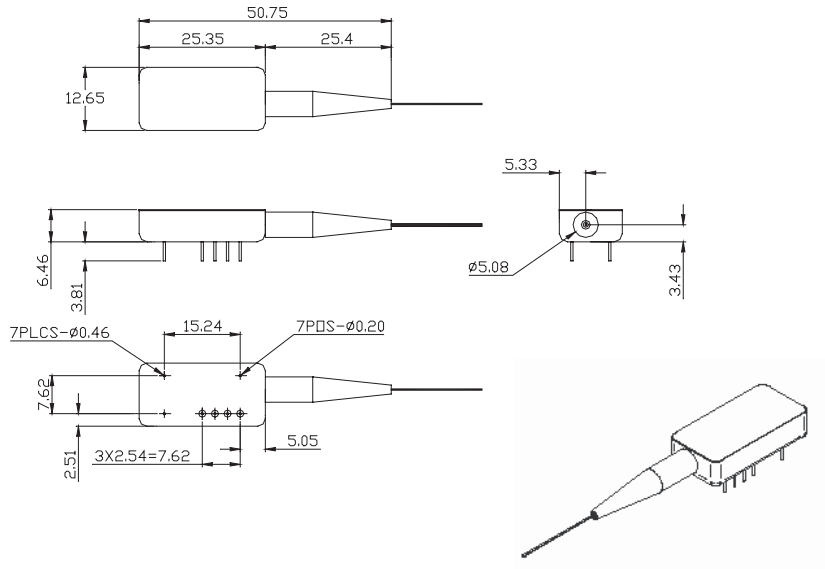

## Dimensions Diagram: TO MATT

(Specifications in mm unless otherwise noted.)

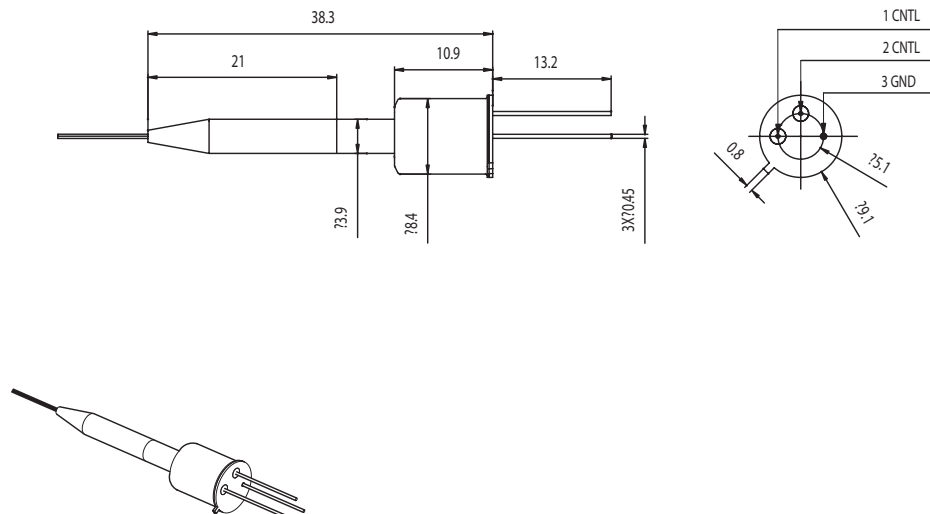

## 3

## Dimensions Diagram: Micro MATT

(Specifications in mm unless otherwise noted.)

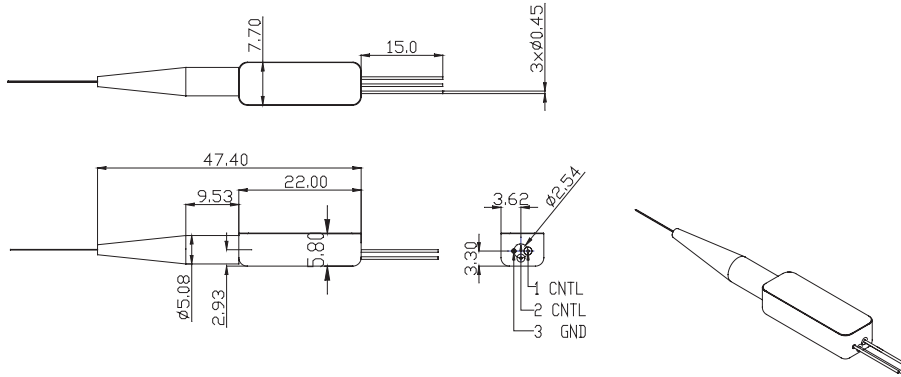

Typical attenuation and PDL profiles  
for the normally open VOA over -5 °C,  
25 °C and 75 °C

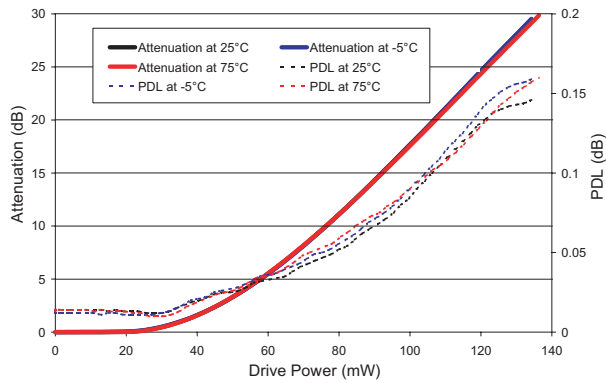

Typical attenuation and PDL profiles  
of the normally closed VOA

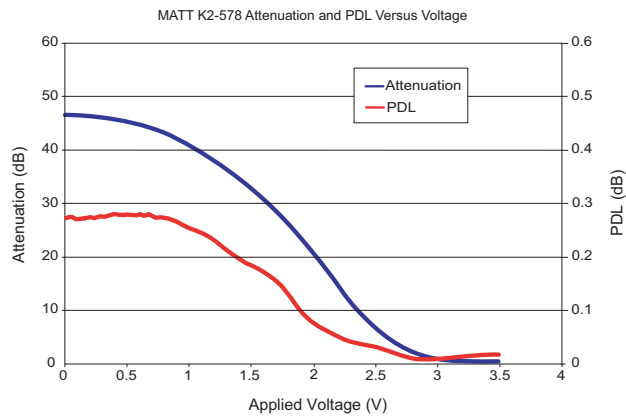

## 4

### Typical insertion loss distribution data for normally open VOA

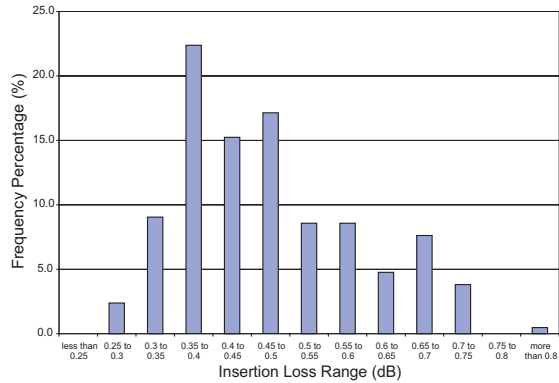

### Typical robustness of the design — ~0.15 dB attenuation change after 10 million cycle dynamic load test on the normally closed VOA

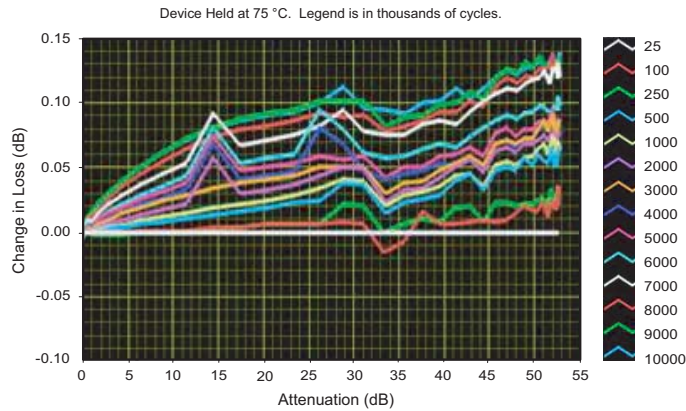

### Typical averaged wavelength dependence variation across C and L bands at ~ 10 dB attenuation setting

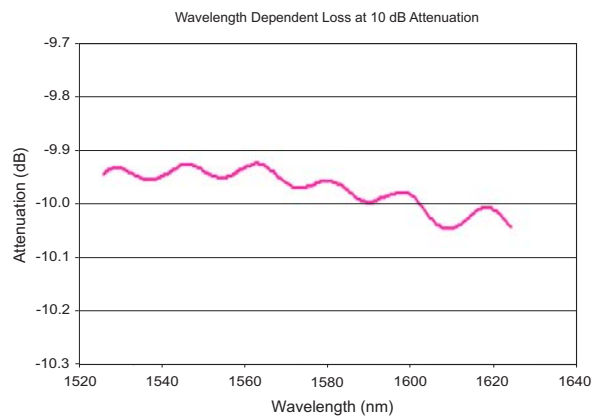

## 5

## Specifications

Parameter		Normally Open	Normally Closed
Recommended method of operation		Constant power	Constant voltage
Operating wavelength range			
C band		1525 to 1575 nm	1525 to 1575 nm
L band		1570 to 1610 nm	1570 to 1610 nm
Attenuation range		25 dB	40 dB
Insertion loss <sup>1</sup>			
BOL	Maximum	0.8 dB (0.5 dB typical)	0.9 dB (0.7 dB typical)
EOL	Maximum	1.0 dB	1.1 dB
Tuning speed <sup>2</sup>		20 ms	20 ms
Optical power handling		24 dBm	24 dBm
Wavelength dependence <sup>3</sup>			
Flatness	Maximum	0.3 dB (0.2 dB typical)	0.5 dB (0.3 dB typical)
Ripple	Maximum	0.15 dB (0.08 dB typical)	0.15 dB (0.08 dB typical)
Polarization dependence loss <sup>1,3</sup>			
0 to 10 dB	Maximum	0.1 dB (0.06 dB typical)	0.1 dB (0.06 dB typical)
10 to 20 dB	Maximum	0.2 dB (0.12 dB typical)	0.2 dB (0.12 dB typical)
20 to 30 dB	Maximum	-	0.3 dB (0.22 dB typical)
Temperature dependence of attenuation <sup>4</sup>			
at IL	Maximum	±0.3 dB (<0.1 dB typical)	±0.3 dB (<0.1 dB typical)
at 10 dB	Maximum	±0.5 dB (±0.2 dB typical)	±1.2 dB (±0.5 dB typical)
at 20 dB	Maximum	±0.7 dB (±0.3 dB typical)	±1.2 dB (±0.5 dB typical)
at 30 dB	Maximum	-	±1.2 dB (±0.5 dB typical)
Repeatability	Maximum	0.1 dB	0.1 dB
Return loss <sup>1</sup>	Minimum	50 dB	45 dB
Drive voltage <sup>2</sup>	Maximum	6 V DC	5 V DC
Device resistance	Maximum	240 Ω	200 Ω
Peak power consumption <sup>2</sup>		150 mW (120 mW typical)	150 mW (120 mW typical)
Fiber type		9/125/250 Corning SMF-28	9/125/250 Corning SMF-28
Fiber marking			
Input port		Clear	Clear
Output port		Red	Red
Operating temperature		-5 to 75 °C	-5 to 75 °C
Reliability qualification		Telcordia 1209 and 1221	Telcordia 1209 and 1221

1. Excluding connectors.

2. For full dynamic range.

3. Over 0-20 dB attenuation for normally open, 0-30 dB attenuation for normally closed, at 1550nm.

4. Relative to 23±3 °C; under constant drive power for normally open; under constant drive voltage for normally closed.

**Ordering Information**

For more information on this or other products and their availability, please contact your local JDSU account manager or JDSU directly at 1-800-498-JDSU (5378) in North America and +800-5378-JDSU worldwide or via e-mail at [customer.service@jdsu.com](mailto:customer.service@jdsu.com).

**Sample: MAT-0TDO210**
**MAT-OT**

Code	Package
D	DIL MATT
M	Micro MATT
T	TO MATT

**2**

Code	State
C	Normally closed
O	Normally open



Code	Pigtail Length
1	1.0 meter



Code	Connector Type
0	No connector

SMF-28 is a registered trademark of Corning Incorporated.  
 Telcordia is a registered trademark of Telcordia Technologies Incorporated.

All statements, technical information and recommendations related to the products herein are based upon information believed to be reliable or accurate. However, the accuracy or completeness thereof is not guaranteed, and no responsibility is assumed for any inaccuracies. The user assumes all risks and liability whatsoever in connection with the use of a product or its application. JDSU reserves the right to change at any time without notice the design, specifications, function, fit or form of its products described herein, including withdrawal at any time of a product offered for sale herein. JDSU makes no representations that the products herein are free from any intellectual property claims of others. Please contact JDSU for more information. JDSU and the JDSU logo are trademarks of JDS Uniphase Corporation. Other trademarks are the property of their respective holders. ©2006 JDS Uniphase Corporation. All rights reserved. 21027455 Rev. 004 02/06 MATT.DS.CC.AE