

**DP-25BD 3PDT, 100 Amps,
115/200 VAC, 400 Hz**

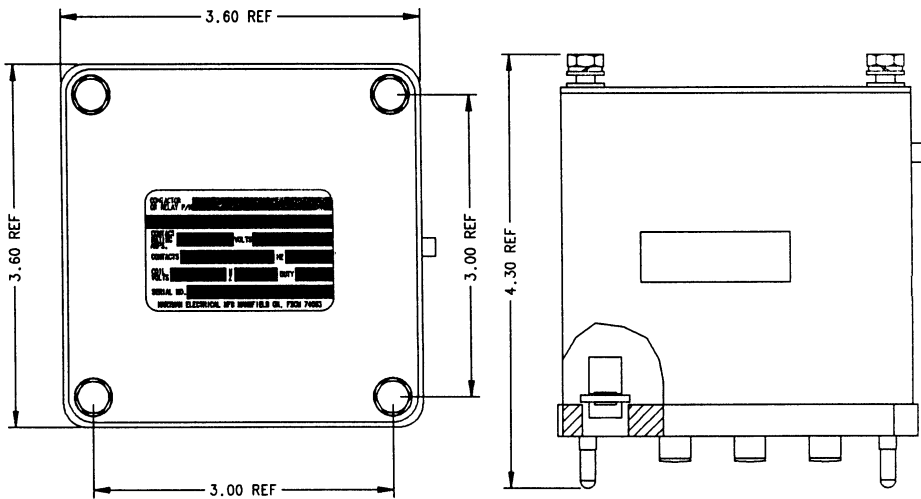
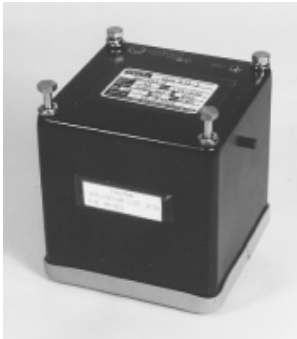

Dimensions for this product are expressed in inches. Multiply values by 25.4 for millimeters.

Features:

- 3PDT Main Contacts
- Mechanically Interlocked
- Designed for ease of maintenance
- Less than 10µ contact chatter during high vibration
- 115/200 VAC, 400 Hz
- 100 Amps
- High Reliability
- Meets many requirements of MIL-R-6106
- Light Weight Construction

CONTACTOR CONFIGURATION

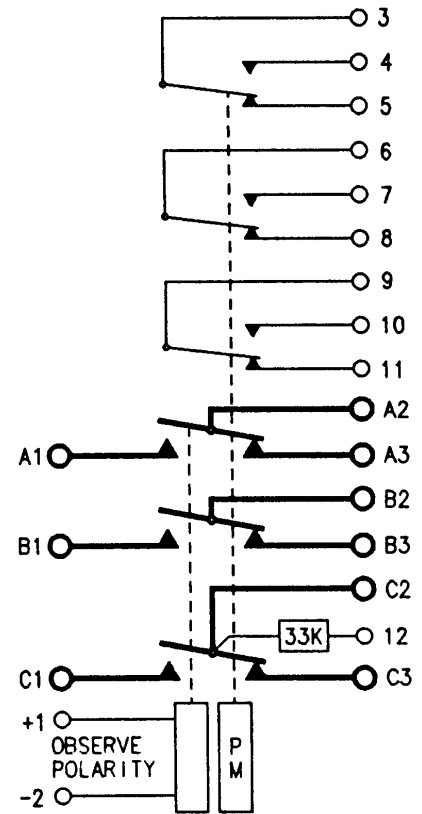

Notes:

PRODUCT SPECIFICATIONS	
Construction	Gasket Sealed, Vented, Plug-In
Main Contacts:	
Configuration	3PDT
Voltage (Nominal)	115/200 VAC, 400 Hz
Current	100 Amps
Auxiliary Contacts:	
Configuration	3-SPDT
Voltage (Nominal)	28 VDC
Current (Resistive)	5 Amps
Coil Data:	
Duty Cycle	Continuous
Voltage (Nominal)	28 VDC
Pick-Up Voltage	18 VDC Maximum
Drop-Out Voltage	1.5 - 7 VDC
Coil Current @ 28 VDC & +25°C	.34 Amps Maximum
Operating Temperature	-15°C to +70°C
Life:	
Electrical	50,000 Cycles
Mechanical	100,000 Cycles
Weight	2 Lbs. 6 Oz.

For factory-direct application assistance, contact the HARTMAN product team at (419) 521-9500, Fax (419) 526-2749.

© 2004 by Tyco Electronics Corporation. All Rights Reserved. HARTMAN and TYCO are trademarks.

Catalog (web doc only)
Revised 5-04

Dimensions are in inches and millimeters unless otherwise specified. Values in brackets are metric equivalents.

Dimensions are shown for reference purposes only. Specifications subject to change.

USA: 1-800-522-6752
 Canada: 1-905-470-4425
 Mexico: 01-800-733-8926
 C. America: 52-55-5-729-0425

South America: 55-11-3611-1514
 Hong Kong: 852-2735-1628
 Japan: 81-44-844-8013
 UK: 44-141-810-8967