

# S71GL512NB0/S71GL256NB0/ S71GL128NB0



**Stacked Multi-chip Product (MCP)  
512/256/128 Megabit (32/16/8 M x 16-bit) CMOS 3.0 Volt-only  
MirrorBit™ Page-mode Flash Memory with  
32 Megabit (2M x 16-bit) pSRAM**

**ADVANCE  
INFORMATION**

## Distinctive Characteristics

### MCP Features

- Power supply voltage of 2.7 to 3.1V

### High Performance

- 90 ns access time (S71GL128N, S71GL256N)
- 100 ns access time (S71GL512N)
- 25 ns page read times
- Packages:
  - 9.0 x 12.0 mm x 1.2 mm FBGA (TLD084) (S71GL512N)
  - 8.0 x 11.6 mm x 1.2 mm FBGA (TLA084) (S71GL128N, S71GL256N)
- Operating Temperature
  - -25°C to +85°C (Wireless)
  - -40°C to +85°C (Industrial)

## General Description

The S71GL Series is a product line of stacked Multi-chip Product (MCP) packages and consists of

- One Flash memory die
- one pSRAM

The products covered by this document are listed in the table below. For details about their specifications, please refer to the individual constituent datasheets for further details.

		Flash Memory Density		
		512 Mb	256 Mb	128 Mb
pSRAM Density	128 Mb			
	64 Mb			
	32 Mb	S71GL512NB0	S71GL256NB0	S71GL128NB0
	16 Mb			

Publication Number S71GL512\_256\_128NB0\_00 Revision A Amendment I Issue Date December 7, 2004

This document contains information on a product under development at Spansion LLC. The information is intended to help you evaluate this product. Spansion LLC reserves the right to change or discontinue work on this proposed product without notice.

**S71GL512NB0/S71GL256NB0/S71GL128NB0**

**General Description** ..... 1  
**Product Selector Guide** ..... 4  
 MCP Block Diagram (128Mb Flash + 32Mb pSRAM) ..... 5  
 MCP Block Diagram (256Mb Flash + 32Mb pSRAM) ..... 5  
 MCP Block Diagram (512Mb Flash + 32Mb pSRAM) ..... 6  
**Connection Diagrams** ..... 7  
 512 Mb Flash + 32 Mb pSRAM Pinout ..... 7  
 256 Mb Flash + 32 Mb pSRAM Pinout ..... 8  
 128 Mb Flash + 32 Mb pSRAM Pinout ..... 9  
 128 Mb Flash + 32 Mb pSRAM Pinout (S71GL128NB0 Only) ..... 10  
**Input/Output Descriptions** ..... 11  
**Logic Symbol** ..... 11  
**Ordering Information** ..... 12  
**Physical Dimensions** ..... 16

**S29GLxxxN MirrorBit™ Flash Family**

**Datasheet** ..... 19  
**General Description** ..... 20  
**Block Diagram** ..... 22  
**Device Bus Operations** ..... 23  
 Table 1. Device Bus Operations ..... 23  
 Word/Byte Configuration ..... 23  
 Requirements for Reading Array Data ..... 23  
 Page Mode Read ..... 24  
 Writing Commands/Command Sequences ..... 24  
 Write Buffer ..... 24  
 Accelerated Program Operation ..... 25  
 Autoselect Functions ..... 25  
 Standby Mode ..... 25  
 Automatic Sleep Mode ..... 25  
 RESET#: Hardware Reset Pin ..... 25  
 Output Disable Mode ..... 26  
 Table 2. Sector Address Table–S29GL256N ..... 26  
 Table 3. Sector Address Table–S29GL128N ..... 33  
 Sector Protection ..... 37  
 Persistent Sector Protection ..... 37  
 Password Sector Protection ..... 37  
 WP# Hardware Protection ..... 37  
 Selecting a Sector Protection Mode ..... 37  
 Advanced Sector Protection ..... 38  
 Lock Register ..... 38  
 Table 4. Lock Register ..... 39  
 Persistent Sector Protection ..... 39  
 Dynamic Protection Bit (DYB) ..... 39  
 Persistent Protection Bit (PPB) ..... 40  
 Persistent Protection Bit Lock (PPB Lock Bit) ..... 41  
 Table 5. Sector Protection Schemes ..... 41  
 Persistent Protection Mode Lock Bit ..... 41  
 Password Sector Protection ..... 42  
 Password and Password Protection Mode Lock Bit ..... 42  
 64-bit Password ..... 43  
 Persistent Protection Bit Lock (PPB Lock Bit) ..... 43  
 Secured Silicon Sector Flash Memory Region ..... 43  
 Write Protect (WP#) ..... 45  
 Hardware Data Protection ..... 45  
 Low VCC Write Inhibit ..... 45  
 Write Pulse “Glitch” Protection ..... 45

Logical Inhibit ..... 45  
 Power-Up Write Inhibit ..... 45  
**Common Flash Memory Interface (CFI)** ..... 45  
 Table 6. CFI Query Identification String ..... 47  
 Table 7. System Interface String ..... 47  
 Table 8. Device Geometry Definition ..... 48  
 Table 9. Primary Vendor-Specific Extended Query ..... 49  
**Command Definitions** ..... 49  
 Reading Array Data ..... 50  
 Reset Command ..... 50  
 Autoselect Command Sequence ..... 50  
 Enter Secured Silicon Sector/Exit Secured Silicon  
 Sector Command Sequence ..... 51  
 Word Program Command Sequence ..... 51  
 Unlock Bypass Command Sequence ..... 52  
 Write Buffer Programming ..... 52  
 Accelerated Program ..... 53  
 Figure 1. Write Buffer Programming Operation ..... 54  
 Figure 2. Program Operation ..... 55  
 Program Suspend/Program Resume Command Sequence ..... 55  
 Figure 3. Program Suspend/Program Resume ..... 56  
 Chip Erase Command Sequence ..... 56  
 Sector Erase Command Sequence ..... 57  
 Figure 4. Erase Operation ..... 58  
 Erase Suspend/Erase Resume Commands ..... 58  
 Lock Register Command Set Definitions ..... 59  
 Password Protection Command Set Definitions ..... 59  
 Non-Volatile Sector Protection Command Set Definitions ..... 61  
 Global Volatile Sector Protection Freeze Command Set ..... 61  
 Volatile Sector Protection Command Set ..... 62  
 Secured Silicon Sector Entry Command ..... 62  
 Secured Silicon Sector Exit Command ..... 63  
 Command Definitions ..... 64  
 Table 10. S29GL512N, S29GL256N, S29GL128N Command  
 Definitions, x16 ..... 64  
 Table 11. S29GL512N, S29GL256N, S29GL128N Command  
 Definitions, x8 ..... 67  
 Write Operation Status ..... 69  
 DQ7: Data# Polling ..... 70  
 Figure 5. Data# Polling Algorithm ..... 71  
 RY/BY#: Ready/Busy# ..... 71  
 DQ6: Toggle Bit I ..... 72  
 Figure 6. Toggle Bit Algorithm ..... 73  
 DQ2: Toggle Bit II ..... 73  
 Reading Toggle Bits DQ6/DQ2 ..... 74  
 DQ5: Exceeded Timing Limits ..... 74  
 DQ3: Sector Erase Timer ..... 75  
 DQ1: Write-to-Buffer Abort ..... 75  
 Table 12. Write Operation Status ..... 76  
**Absolute Maximum Ratings** ..... 76  
 Figure 7. Maximum Negative Overshoot Waveform ..... 77  
 Figure 8. Maximum Positive  
 Overshoot Waveform ..... 77  
**Operating Ranges** ..... 77  
**DC Characteristics** ..... 78  
**Test Conditions** ..... 79  
 Figure 9. Test Setup ..... 79  
 Table 13. Test Specifications ..... 79  
**Key to Switching Waveforms** ..... 79  
 Figure 10. Input Waveforms and Measurement Levels ..... 79  
**AC Characteristics** ..... 80

Read-Only Operations–S29GL512N Only ..... 80  
 Read-Only Operations–S29GL256N Only ..... 81  
 Read-Only Operations–S29GLI28N Only ..... 82  
 Figure 11. Read Operation Timings ..... 83  
 Figure 12. Page Read Timings ..... 83  
 Hardware Reset (RESET#) ..... 84  
 Figure 13. Reset Timings ..... 84  
 Erase and Program Operations–S29GL512N Only ..... 85  
 Erase and Program Operations–S29GL256N Only ..... 86  
 Erase and Program Operations–S29GLI28N Only ..... 87  
 Figure 14. Program Operation Timings ..... 88  
 Figure 15. Accelerated Program Timing Diagram ..... 88  
 Figure 16. Chip/Sector Erase Operation Timings ..... 89  
 Figure 17. Data# Polling Timings  
 (During Embedded Algorithms) ..... 90  
 Figure 18. Toggle Bit Timings (During Embedded Algorithms) .. 91  
 Figure 19. DQ2 vs. DQ6 ..... 91  
 Alternate CE# Controlled Erase and Program Operations–  
 S29GL512N Only ..... 92  
 Alternate CE# Controlled Erase and Program Operations–  
 S29GL256N Only ..... 93  
 Alternate CE# Controlled Erase and Program Operations–  
 S29GLI28N Only ..... 94  
 Figure 20. Alternate CE# Controlled Write (Erase/Program)  
 Operation Timings ..... 95  
**Latchup Characteristics ..... 95**  
**Erase And Programming Performance ..... 96**  
**TSOP Pin and BGA Package Capacitance ..... 96**

**pSRAM Type I**

**Functional Description ..... 97**  
**Absolute Maximum Ratings ..... 97**  
**Timing Test Conditions ..... 103**  
 Output Load Circuit ..... 104  
 Figure 21. Output Load Circuit ..... 104  
**Power Up Sequence ..... 104**  
**AC Characteristics ..... 105**  
**Timing Diagrams ..... 116**  
 Read Cycle ..... 116  
 Figure 22. Timing of Read Cycle (CE# = OE# =  $V_{IL}$ , WE# = ZZ# =  $V_{IH}$ ) ..... 116  
 Figure 23. Timing Waveform of Read Cycle  
 (WE# = ZZ# =  $V_{IH}$ ) ..... 117  
 Figure 24. Timing Waveform of Page Mode Read Cycle (WE# = ZZ# =  $V_{IH}$ ) ..... 118  
 Write Cycle ..... 119  
 Figure 25. Timing Waveform of Write Cycle (WE# Control, ZZ# =  $V_{IH}$ ) ..... 119  
 Figure 26. Timing Waveform of Write Cycle (CE# Control, ZZ# =  $V_{IH}$ ) ..... 119  
 Figure 27. Timing Waveform of Page Mode  
 Write Cycle (ZZ# =  $V_{IH}$ ) ..... 120  
 Partial Array Self Refresh (PAR) ..... 120  
 Temperature Compensated Refresh (for 64Mb) ..... 121  
 Deep Sleep Mode ..... 121  
 Reduced Memory Size (for 32M and 16M) ..... 121  
 Other Mode Register Settings (for 64M) ..... 121

Figure 28. Mode Register ..... 122  
 Figure 29. Mode Register Update Timings (UB#, LB#, OE# are Don't  
 Care) ..... 122  
 Figure 30. Deep Sleep Mode - Entry/Exit Timings (for 64M) ... 123  
 Figure 31. Deep Sleep Mode - Entry/Exit Timings  
 (for 32M and 16M) ..... 123

**pSRAM Type 7**

**Features ..... 127**  
**Pin Description ..... 127**  
**Functional Description ..... 128**  
 Power Down ..... 128  
 Power Down Program Sequence ..... 129  
 Address Key ..... 129  
**Absolute Maximum Ratings ..... 130**  
**Package Capacitance ..... 130**  
 Read Operation ..... 132  
**AC Characteristics ..... 134**  
 Write Operation ..... 134  
 Power Down Parameters ..... 135  
 Other Timing Parameters ..... 135  
 AC Test Conditions ..... 136  
 AC Measurement Output Load Circuit ..... 136  
 Figure 32. AC Output Load Circuit ..... 136  
**Timing Diagrams ..... 137**  
 Read Timings ..... 137  
 Figure 33. Read Timing #1 (Basic Timing) ..... 137  
 Figure 34. Read Timing #2 (OE# Address Access) ..... 137  
 Figure 35. Read Timing #3 (LB#/UB# Byte Access) ..... 138  
 Figure 36. Read Timing #4 (Page Address Access after CE1# Control  
 Access for 32M and 64M Only) ..... 138  
 Figure 37. Read Timing #5 (Random and Page Address Access for  
 32M and 64M Only) ..... 139  
 Write Timings ..... 139  
 Figure 38. Write Timing #1 (Basic Timing) ..... 139  
 Figure 39. Write Timing #2 (WE# Control) ..... 140  
 Figure 40. Write Timing #3-1  
 (WE#/LB#/UB# Byte Write Control) ..... 140  
 Figure 41. Write Timing #3-2  
 (WE#/LB#/UB# Byte Write Control) ..... 141  
 Figure 42. Write Timing #3-3  
 (WE#/LB#/UB# Byte Write Control) ..... 141  
 Figure 43. Write Timing #3-4  
 (WE#/LB#/UB# Byte Write Control) ..... 142  
 Read/Write Timings ..... 142  
 Figure 44. Read/Write Timing #1-1 (CE1# Control) ..... 142  
 Figure 45. Read / Write Timing #1-2  
 (CE1#/WE#/OE# Control) ..... 143  
 Figure 46. Read / Write Timing #2 (OE#, WE# Control) ..... 143  
 Figure 47. Read / Write Timing #3  
 (OE#, WE#, LB#, UB# Control) ..... 144  
 Figure 48. Power-up Timing #1 ..... 144  
 Figure 49. Power-up Timing #2 ..... 145  
 Figure 50. Power Down Entry and Exit Timing ..... 145  
 Figure 51. Standby Entry Timing after Read or Write ..... 145  
 Figure 52. Power Down Program Timing (for 32M/64M Only) . 146  
**Revision Summary ..... 147**

## Product Selector Guide

<b>S7IGL512NB0</b>			
<b>Access Times at <math>V_{CC} = 2.7 - 3.1 V</math></b>	<b>Flash</b>		<b>pSRAM</b>
Max. Access Time (ns)	100	105	65
Max. CE# Access Time (ns)	100	105	65
Max. Page Access Time ( $t_{PACC}$ )	25		25
Max. OE# Access Time (ns)	25		25

<b>S7IGL256NB0</b>			
<b>Access Times at <math>V_{CC} = 2.7 - 3.1 V</math></b>	<b>Flash</b>		<b>pSRAM</b>
Max. Access Time (ns)	90	100	65
Max. CE# Access Time (ns)	90	100	65
Max. Page Access Time ( $t_{PACC}$ )	25		25
Max. OE# Access Time (ns)	25		25

<b>S7IGLI28NB0</b>			
<b>Access Times at <math>V_{CC} = 2.7 - 3.1 V</math></b>	<b>Flash</b>		<b>pSRAM</b>
Max. Access Time (ns)	90	100	65
Max. CE# Access Time (ns)	90	100	65
Max. Page Access Time ( $t_{PACC}$ )	25		25
Max. OE# Access Time (ns)	25		25

### MCP Block Diagram (128Mb Flash + 32Mb pSRAM)

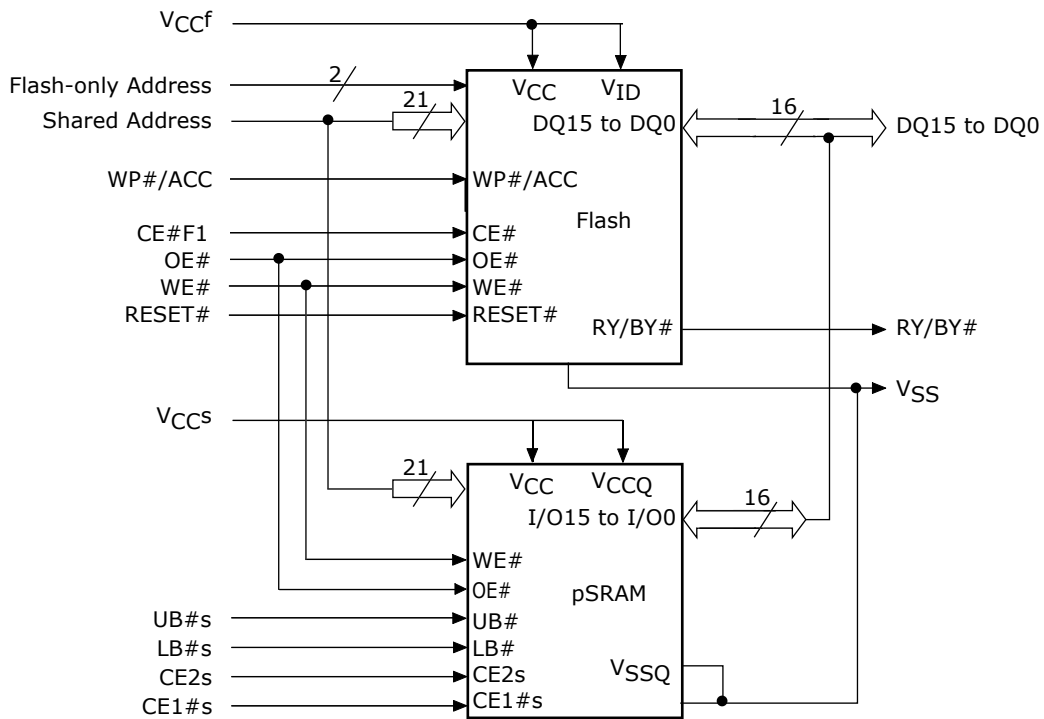

### MCP Block Diagram (256Mb Flash + 32Mb pSRAM)

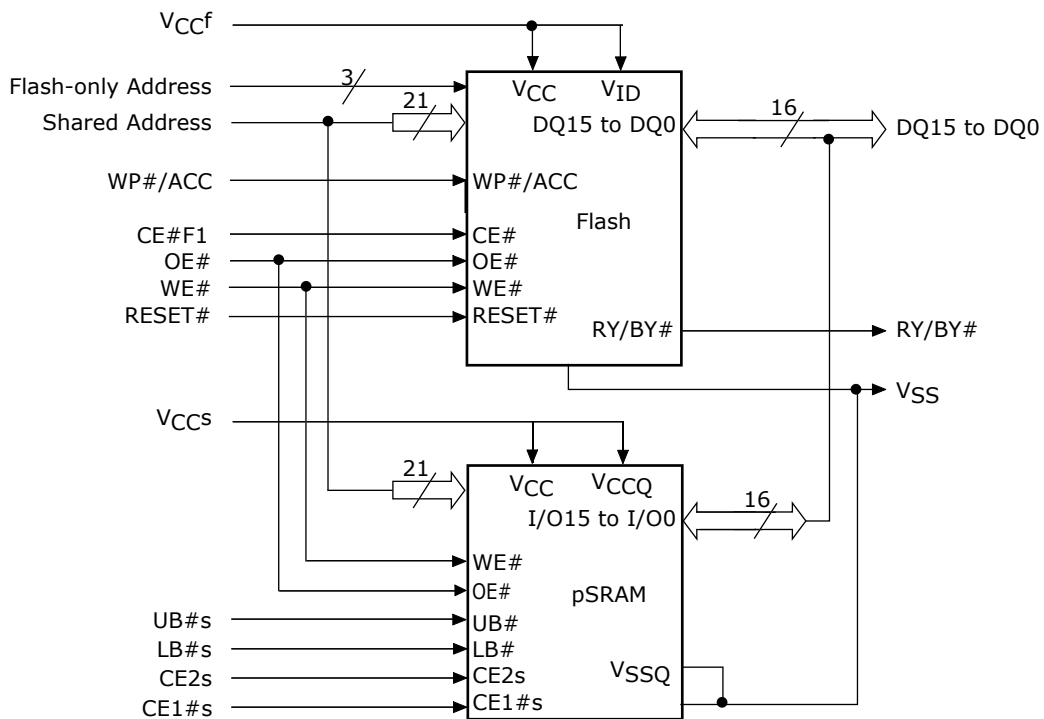

**MCP Block Diagram (512Mb Flash + 32Mb pSRAM)**

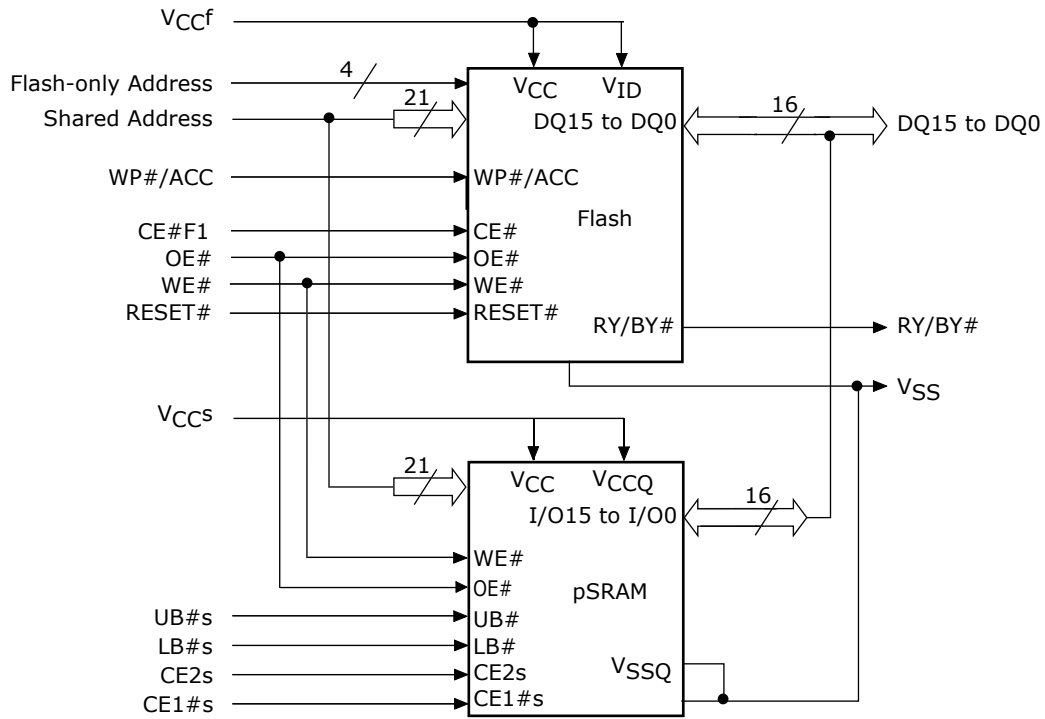

## Connection Diagrams

### 512 Mb Flash + 32 Mb pSRAM Pinout

**84-ball Fine-Pitch Ball Grid Array**  
**512 Mb Flash + 32 Mb pSRAM**  
 Pinout  
 (Top View, Balls Facing Down)

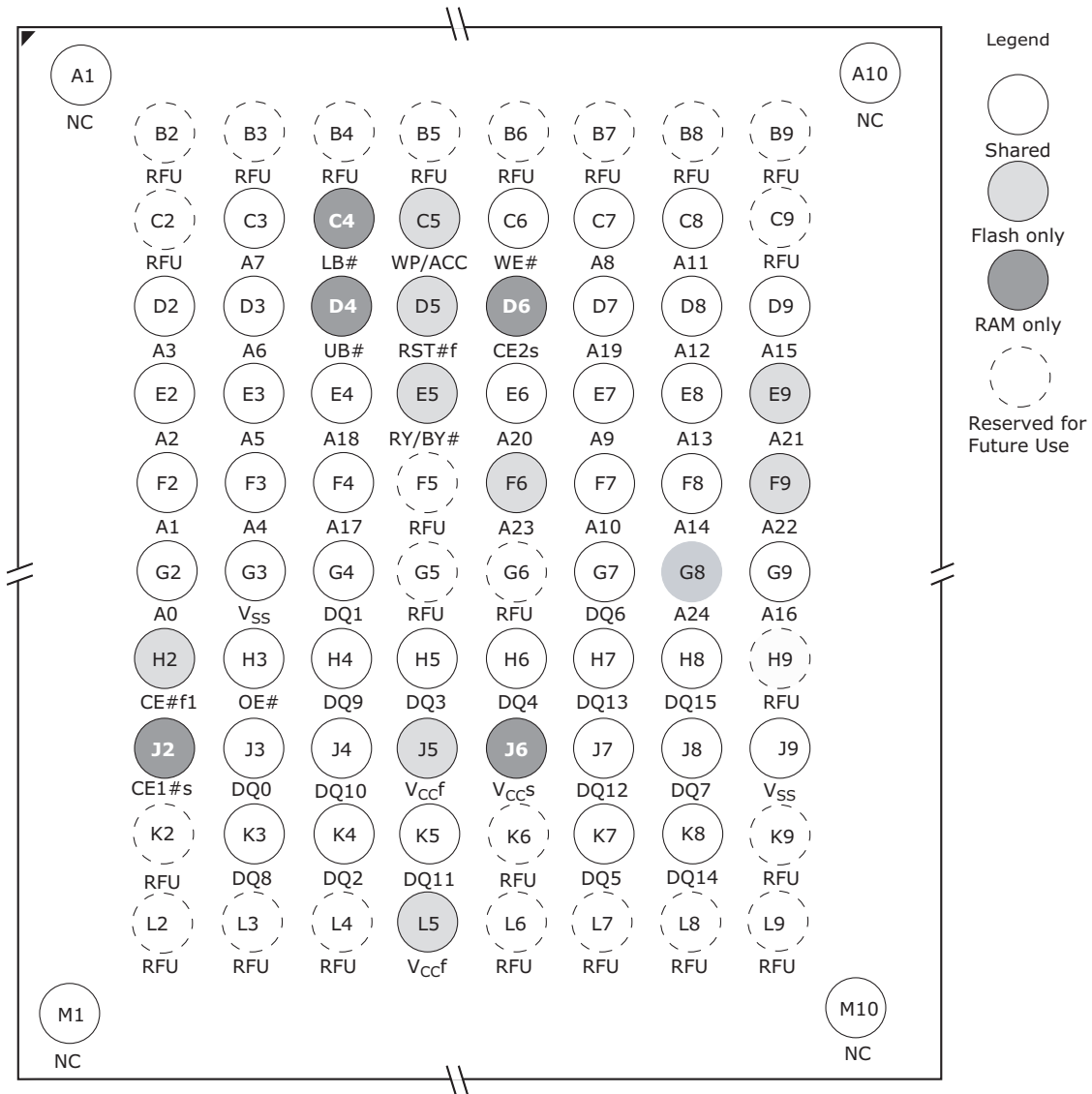

## 256 Mb Flash + 32 Mb pSRAM Pinout

**84-ball Fine-Pitch Ball Grid Array**  
**256 Mb Flash + 32 Mb pSRAM**  
 Pinout  
 (Top View, Balls Facing Down)

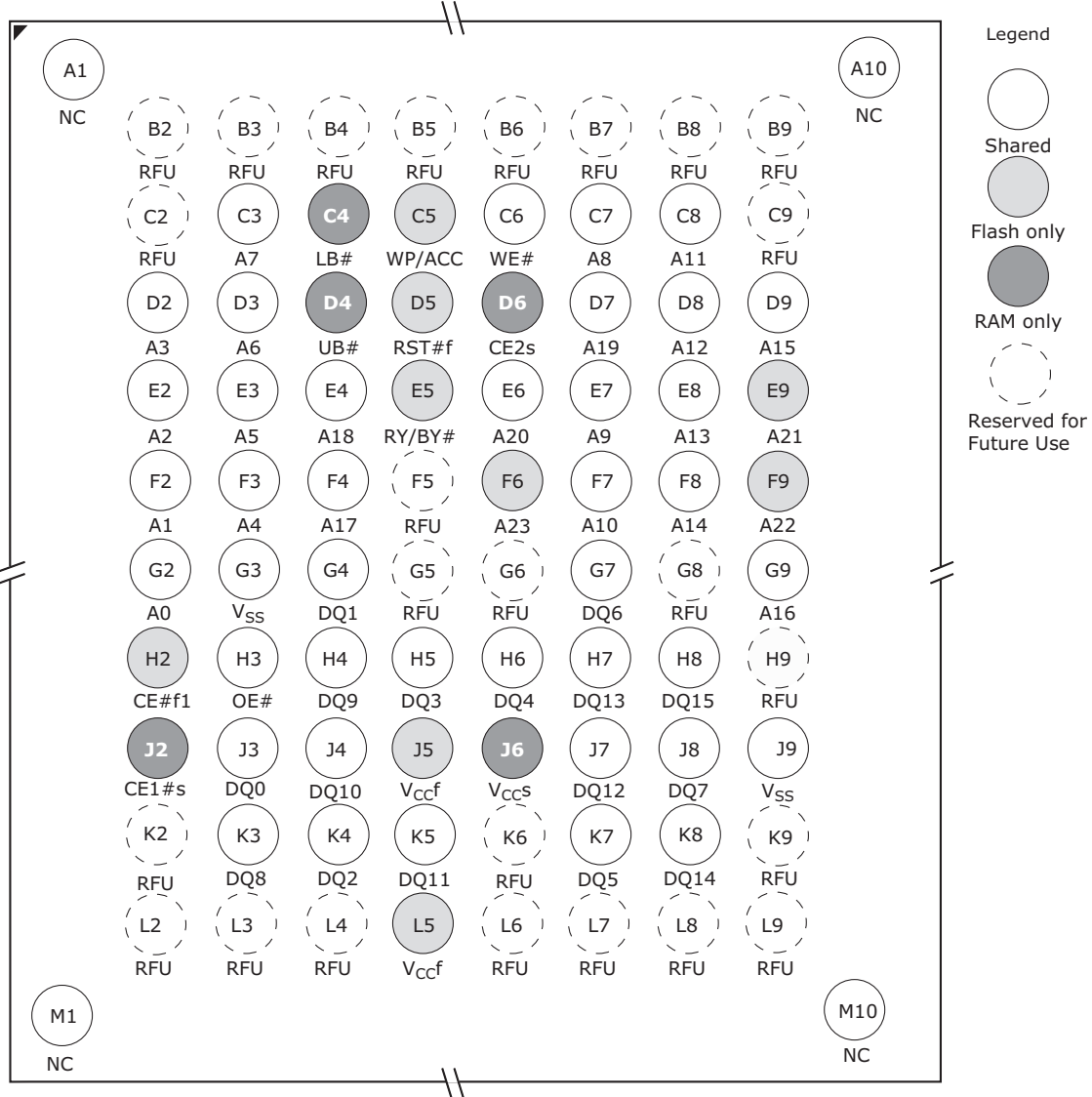



# 128 Mb Flash + 32 Mb pSRAM Pinout

**84-ball Fine-Pitch Ball Grid Array**  
**128 Mb Flash + 32 Mb pSRAM**  
 Pinout  
 (Top View, Balls Facing Down)

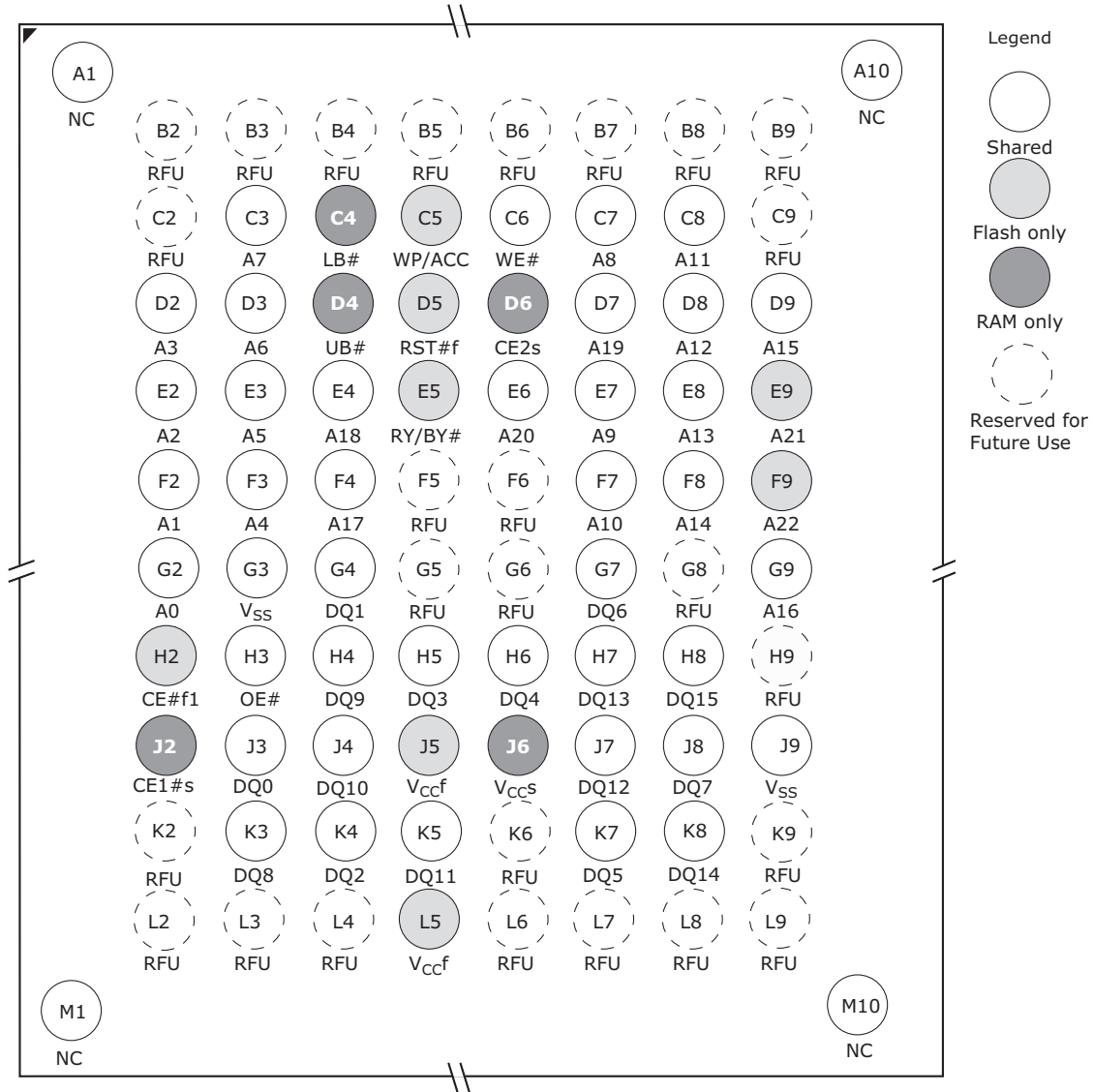

## 128 Mb Flash + 32 Mb pSRAM Pinout (S71GL128NB0 Only)

**64-ball Fine-Pitch Ball Grid Array**  
(Top View, Balls Facing Down)

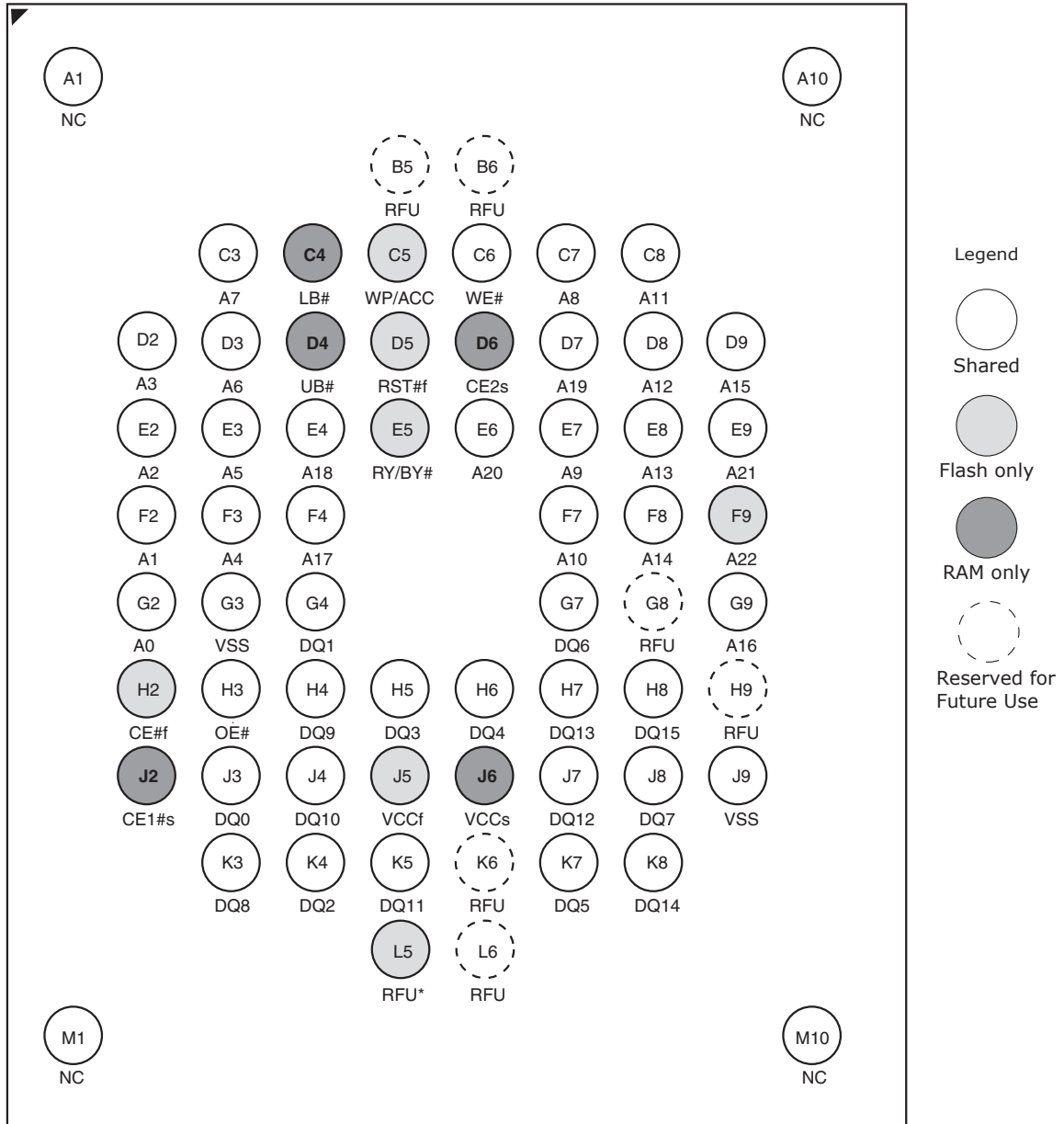

**Note:** Ball L5 (RFU) is a  $V_{CC}$  on an 84-ball package; therefore, it is recommended that L5 not be connected to  $V_{SS}$ .

## Input/Output Descriptions

A24-A0	=	25 Address inputs (512 Mb)
A23-A0	=	24 Address inputs (256 Mb)
A22-A0	=	23 Address inputs (128 Mb)
DQ15-DQ0	=	Data input/output
OE#	=	Output Enable input. Asynchronous relative to CLK for the Burst mode.
WE#	=	Write Enable input.
V <sub>SS</sub>	=	Ground
NC	=	No Connect; not connected internally
RESET#	=	Hardware reset input. Low = device resets and returns to reading array data
WP#/ACC	=	Hardware write protect input / programming acceleration input.
CE1#s, CE2s	=	Chip-enable input for pSRAM.
CE#f1	=	Chip-enable input for Flash 1.
V <sub>CCf</sub>	=	Flash 3.0 Volt-only single power supply.
V <sub>CCS</sub>	=	pSRAM Power Supply.
UB#s	=	Upper Byte Control (pSRAM).
LB#s	=	Lower Byte Control (pSRAM).
RFU	=	Reserved for future use.
RY/BY#	=	Ready/Busy output.

## Logic Symbol

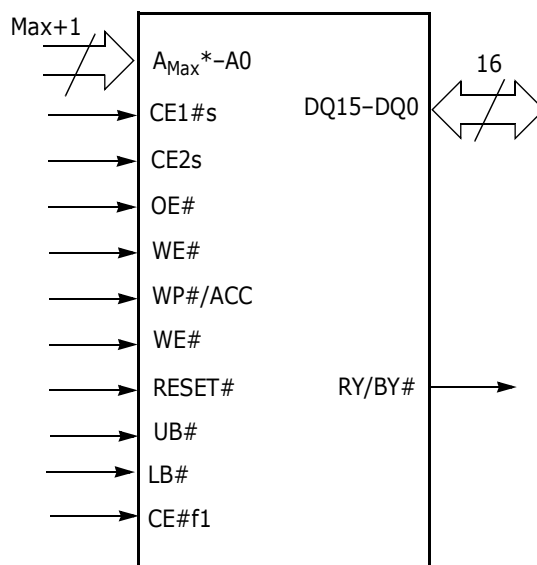

\*Max = A24

## Ordering Information

The order number (Valid Combination) is formed by the following:

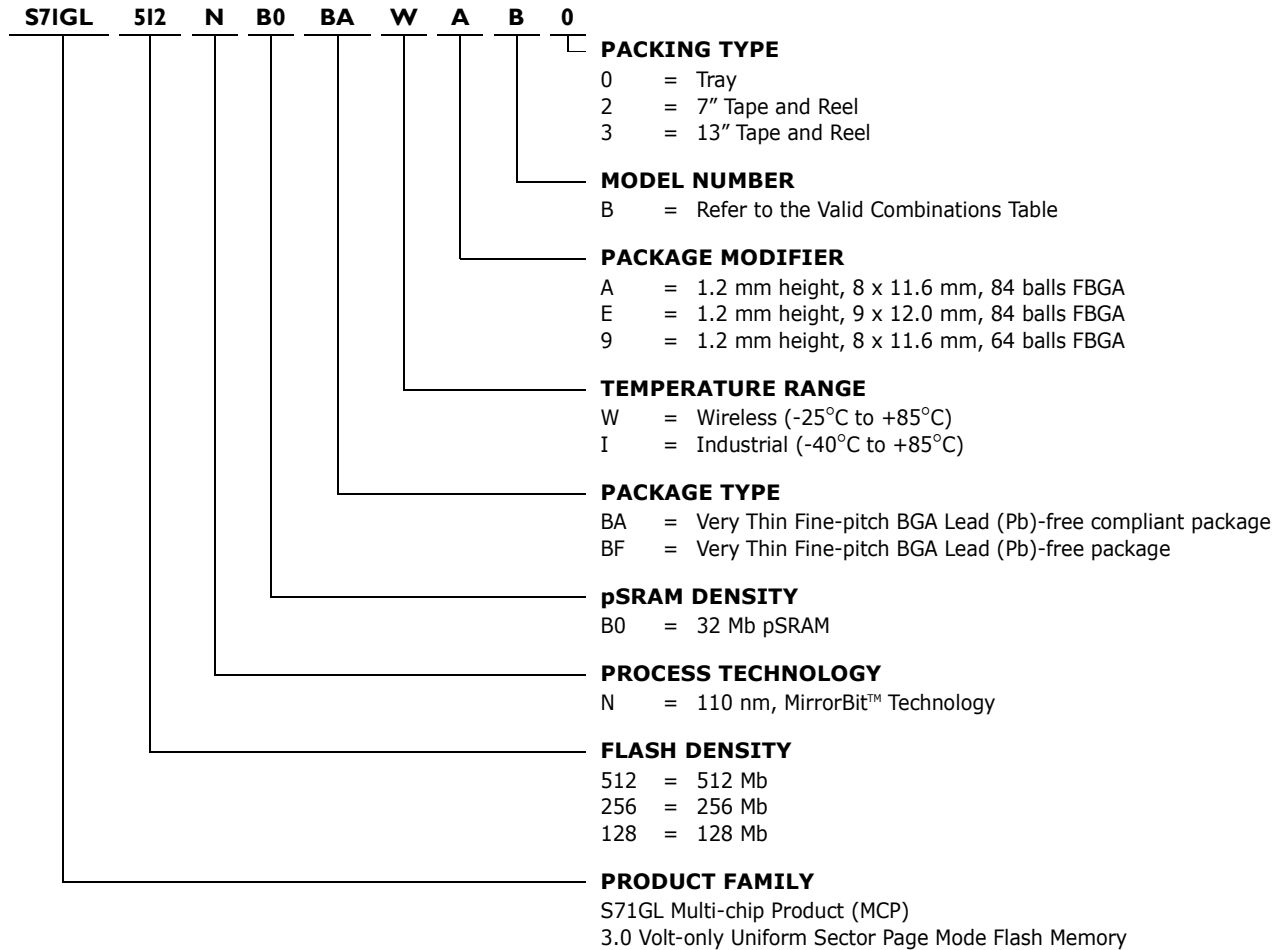

S71GL512NB0 Valid Combinations				Flash Initial/Page Speed (ns)	Address Sector Protection	(p)SRAM Supplier	(p)SRAM Type/ Access Time (ns)	Package Type	Package Marking
Base Ordering Part Number	Package & Temperature	Package Modifier/ Model Number	Packing Type						
S71GL512NB0	BAW	EK	0, 2, 3 (Note 1)	105/25	Lowest Add	Type 1	65/25	9mmx12mm 84-ball Lead (Pb)-free Compliant	(Note 2)
		EP			Highest Add				
		EU			Lowest Add	Type 7			
		EZ			Highest Add				
		EJ		100/25	Lowest Add	Type 1			
		EN			Highest Add				
		ET			Lowest Add	Type 7			
		EY			Highest Add				
S71GL512NB0	BFW	EK	0, 2, 3 (Note 1)	105/25	Lowest Add	Type 1	65/25	9mmx12mm 84-ball Lead (Pb)-free	(Note 2)
		EP			Highest Add				
		EU			Lowest Add	Type 7			
		EZ			Highest Add				
		EJ		100/25	Lowest Add	Type 1			
		EN			Highest Add				
		ET			Lowest Add	Type 7			
		EY			Highest Add				

**Notes:**

1. Type 0 is standard. Specify other options as required.
2. BGA package marking omits leading "S" and packing type designator from ordering part number.

**Valid Combinations**

Valid Combinations list configurations planned to be supported in volume for this device. Consult your local sales office to confirm availability of specific valid combinations and to check on newly released combinations.

S71GL256NB0 Valid Combinations				Flash Initial/ Page Speed (ns)	Address Sector Protection	(p)SRAM Supplier	(p)SRAM Type/ Access Time (ns)	Package Type	Package Marking
Base Ordering Part Number	Package & Temperature	Package Modifier/ Model Number	Packing Type						
S71GL256NB0	BAW	AK	0, 2, 3 (Note 1)	100/25	Lowest Add	Type 1	65/25	8mmx11.6mm 84-ball Lead (Pb)-free Compliant	(Note 2)
		AP			Highest Add				
		AU			Lowest Add	Type 7			
		AZ			Highest Add				
		AJ		90/25	Lowest Add	Type 1			
		AN			Highest Add				
		AT			Lowest Add	Type 7			
		AY			Highest Add				
S71GL256NB0	BFW	AK	0, 2, 3 (Note 1)	100/25	Lowest Add	Type 1	65/25	8mmx11.6mm 84-ball Lead (Pb)-free	(Note 2)
		AP			Highest Add				
		AU			Lowest Add	Type 7			
		AZ			Highest Add				
		AJ		90/25	Lowest Add	Type 1			
		AN			Highest Add				
		AT			Lowest Add	Type 7			
		AY			Highest Add				

**Notes:**

1. Type 0 is standard. Specify other options as required.
2. BGA package marking omits leading "S" and packing type designator from ordering part number.

**Valid Combinations**

Valid Combinations list configurations planned to be supported in volume for this device. Consult your local sales office to confirm availability of specific valid combinations and to check on newly released combinations.

S71GL128NB0 Valid Combinations				Flash Initial/ Page Speed (ns)	Address Sector Protection	(p)SRAM Supplier	(p)SRAM Type/ Access Time (ns)	Package Type	Package Marking
Base Ordering Part Number	Package & Temperature	Package Modifier/ Model Number	Packing Type						
S71GL128NB0	BAW	9K	0, 2, 3 (Note 1)	100/25	Lowest Add	Type 1	65/25	8mmx11.6mm 64-ball Lead (Pb)-free Compliant	(Note 2)
		9P			Highest Add				
		9U			Lowest Add	Type 7			
		9Z			Highest Add				
		9J		90/25	Lowest Add	Type 1			
		9N			Highest Add				
		9T			Lowest Add	Type 7			
		9Y			Highest Add				
		AK		100/25	Lowest Add	Type 1			
		AP			Highest Add				
		AU			Lowest Add	Type 7			
		AZ			Highest Add				
		AJ		90/25	Lowest Add	Type 1			
		AN			Highest Add				
		AT			Lowest Add	Type 7			
		AY			Highest Add				
S71GL128NB0	BFW	9K	0, 2, 3 (Note 1)	100/25	Lowest Add	Type 1	65/25	8mmx11.6mm 64-ball Lead (Pb)-free Compliant	
		9P			Highest Add				
		9U			Lowest Add	Type 7			
		9Z			Highest Add				
		9J		90/25	Lowest Add	Type 1			
		9N			Highest Add				
		9T			Lowest Add	Type 7			
		9Y			Highest Add				
		AK		100/25	Lowest Add	Type 1			
		AP			Highest Add				
		AU			Lowest Add	Type 7			
		AZ			Highest Add				
		AJ		90/25	Lowest Add	Type 1			
		AN			Highest Add				
		AT			Lowest Add	Type 7			
		AY			Highest Add				

**Notes:**

1. Type 0 is standard. Specify other options as required.
2. BGA package marking omits leading "S" and packing type designator from ordering part number.

**Valid Combinations**

Valid Combinations list configurations planned to be supported in volume for this device. Consult your local sales office to confirm availability of specific valid combinations and to check on newly released combinations.

## Physical Dimensions

### TLD084—84-ball Fine-Pitch Ball Grid Array (FBGA) 9.0 x 12.0 x 1.2 mm MCP Compatible Package

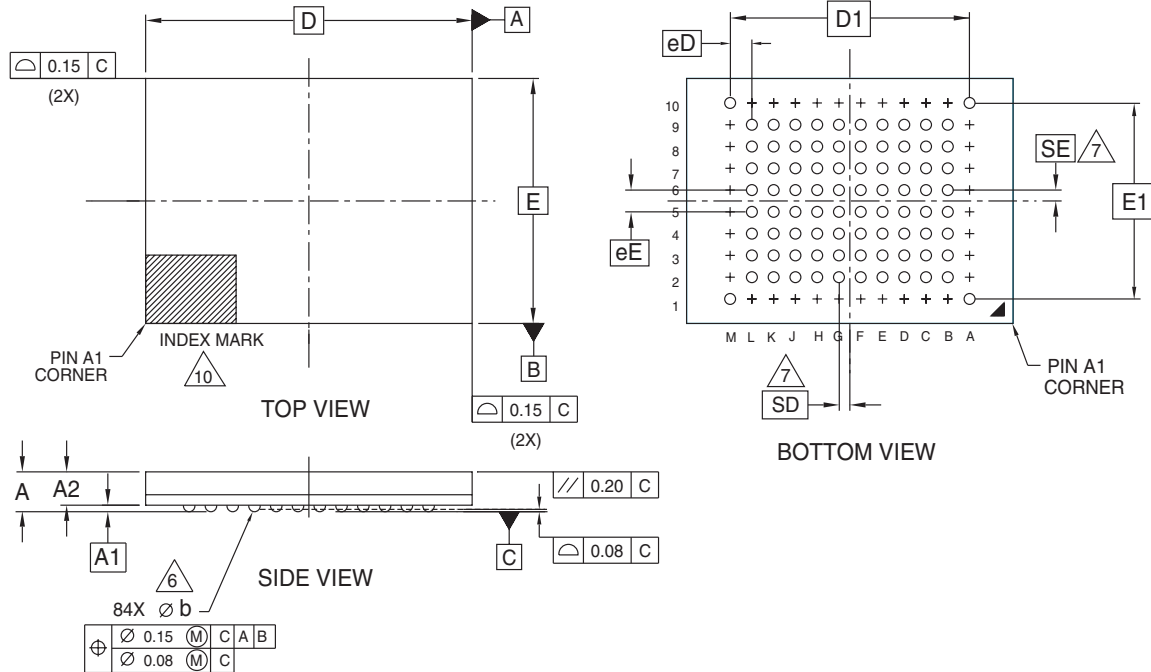

PACKAGE	TLD 084			
JEDEC	N/A			
D x E	12.00 mm x 9.00 mm PACKAGE			
SYMBOL	MIN	NOM	MAX	NOTE
A	---	---	1.20	PROFILE
A1	0.17	---	---	BALL HEIGHT
A2	0.81	---	0.97	BODY THICKNESS
D	12.00 BSC.			BODY SIZE
E	9.00 BSC.			BODY SIZE
D1	8.80 BSC.			MATRIX FOOTPRINT
E1	7.20 BSC.			MATRIX FOOTPRINT
MD	12			MATRIX SIZE D DIRECTION
ME	10			MATRIX SIZE E DIRECTION
n	84			BALL COUNT
b	0.35	0.40	0.45	BALL DIAMETER
eE	0.80 BSC.			BALL PITCH
eD	0.80 BSC.			BALL PITCH
SD / SE	0.40 BSC.			SOLDER BALL PLACEMENT
	A2,A3,A4,A5,A6,A7,A8,A9 B1,B10,C1,C10,D1,D10 E1,E10,F1,F10,G1,G10 H1,H10,J1,J10,K1,K10 L1,L10,M2,M3,M4,M5,M6, M7,M8,M9			DEPOPULATED SOLDER BALLS

NOTES:

- DIMENSIONING AND TOLERANCING METHODS PER ASME Y14.5M-1994.
- ALL DIMENSIONS ARE IN MILLIMETERS.
- BALL POSITION DESIGNATION PER JESD 95-1, SPP-010.
- [e] REPRESENTS THE SOLDER BALL GRID PITCH.
- SYMBOL "MD" IS THE BALL MATRIX SIZE IN THE "D" DIRECTION.  
SYMBOL "ME" IS THE BALL MATRIX SIZE IN THE "E" DIRECTION.  
n IS THE NUMBER OF POPULATED SOLDER BALL POSITIONS FOR MATRIX SIZE MD X ME.
- [6] DIMENSION "b" IS MEASURED AT THE MAXIMUM BALL DIAMETER IN A PLANE PARALLEL TO DATUM C.
- [7] SD AND SE ARE MEASURED WITH RESPECT TO DATUMS A AND B AND DEFINE THE POSITION OF THE CENTER SOLDER BALL IN THE OUTER ROW.  
WHEN THERE IS AN ODD NUMBER OF SOLDER BALLS IN THE OUTER ROW SD OR SE = 0.000.  
WHEN THERE IS AN EVEN NUMBER OF SOLDER BALLS IN THE OUTER ROW, SD OR SE = [e/2]
- "+" INDICATES THE THEORETICAL CENTER OF DEPOPULATED BALLS.
- N/A
- [10] A1 CORNER TO BE IDENTIFIED BY CHAMFER, LASER OR INK MARK, METALLIZED MARK INDENTATION OR OTHER MEANS.

33671 16-038.22a

**Note:** BSC is an ANSI standard for Basic Space Centering



### TLA084—84-ball Fine-Pitch Ball Grid Array (FBGA) 8.0 x 11.6 x 1.2 mm MCP Compatible Package

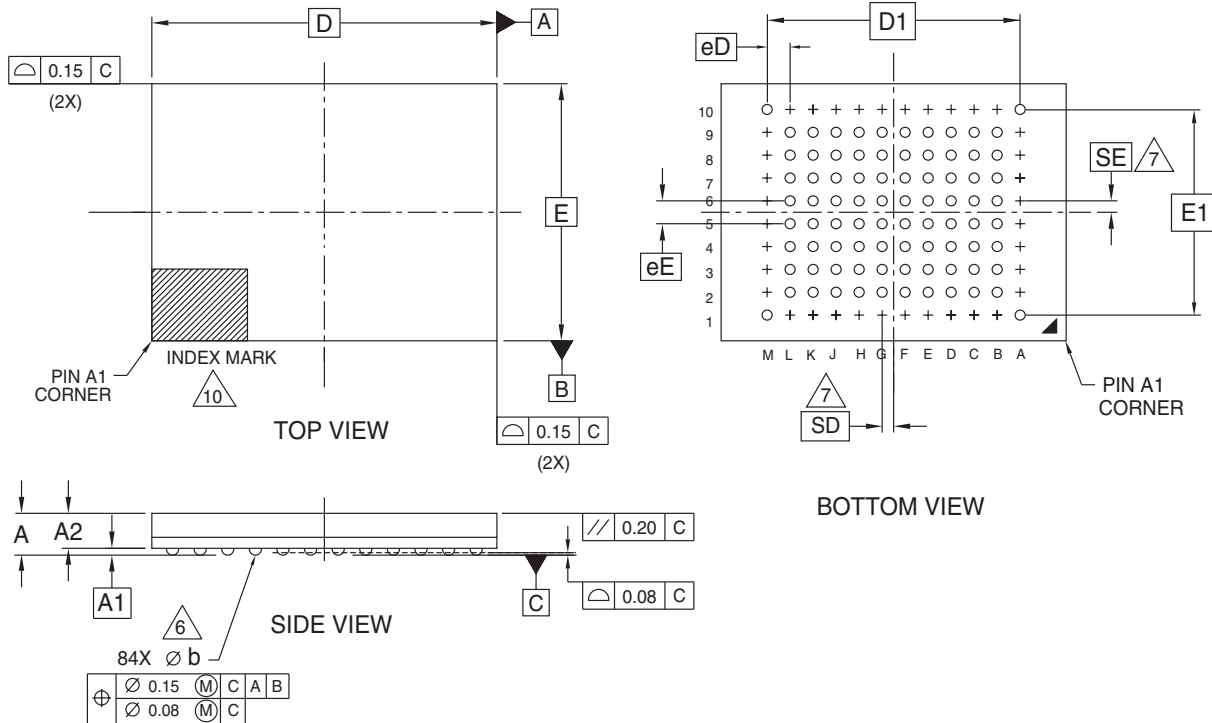

NOTES:

1. DIMENSIONING AND TOLERANCING METHODS PER ASME Y14.5M-1994.
2. ALL DIMENSIONS ARE IN MILLIMETERS.
3. BALL POSITION DESIGNATION PER JESD 95-1, SPP-010.
4. [e] REPRESENTS THE SOLDER BALL GRID PITCH.
5. SYMBOL "MD" IS THE BALL MATRIX SIZE IN THE "D" DIRECTION.  
SYMBOL "ME" IS THE BALL MATRIX SIZE IN THE "E" DIRECTION.  
n IS THE NUMBER OF POPULATED SOLDER BALL POSITIONS FOR MATRIX SIZE MD X ME.
6. DIMENSION "b" IS MEASURED AT THE MAXIMUM BALL DIAMETER IN A PLANE PARALLEL TO DATUM C.
7. SD AND SE ARE MEASURED WITH RESPECT TO DATUMS A AND B AND DEFINE THE POSITION OF THE CENTER SOLDER BALL IN THE OUTER ROW.
- WHEN THERE IS AN ODD NUMBER OF SOLDER BALLS IN THE OUTER ROW SD OR SE = 0.000.
- WHEN THERE IS AN EVEN NUMBER OF SOLDER BALLS IN THE OUTER ROW, SD OR SE = [e/2]
8. "+" INDICATES THE THEORETICAL CENTER OF DEPOPULATED BALLS.
9. N/A
10. A1 CORNER TO BE IDENTIFIED BY CHAMFER, LASER OR INK MARK, METALLIZED MARK INDENTATION OR OTHER MEANS.

PACKAGE	TLA 084			
JEDEC	N/A			
D x E	11.60 mm x 8.00 mm PACKAGE			
SYMBOL	MIN	NOM	MAX	NOTE
A	---	---	1.20	PROFILE
A1	0.17	---	---	BALL HEIGHT
A2	0.81	---	0.97	BODY THICKNESS
D	11.60 BSC.			BODY SIZE
E	8.00 BSC.			BODY SIZE
D1	8.80 BSC.			MATRIX FOOTPRINT
E1	7.20 BSC.			MATRIX FOOTPRINT
MD	12			MATRIX SIZE D DIRECTION
ME	10			MATRIX SIZE E DIRECTION
n	84			BALL COUNT
$\varnothing$ b	0.35	0.40	0.45	BALL DIAMETER
[eE]	0.80 BSC.			BALL PITCH
[eD]	0.80 BSC.			BALL PITCH
SD / SE	0.40 BSC.			SOLDER BALL PLACEMENT
	A2,A3,A4,A5,A6,A7,A8,A9 B1,B10,C1,C10,D1,D10, E1,E10,F1,F10,G1,G10, H1,H10,J1,J10,K1,K10,L1,L10, M2,M3,M4,M5,M6,M7,M8,M9			DEPOPULATED SOLDER BALLS

3372-2 \ 16-038.22a

Note: BSC is an ANSI standard for Basic Space Centering

### TLA064—64-ball Fine-Pitch Ball Grid Array (FBGA) 8.0 x 11.6 x 1.2 mm MCP Compatible Package

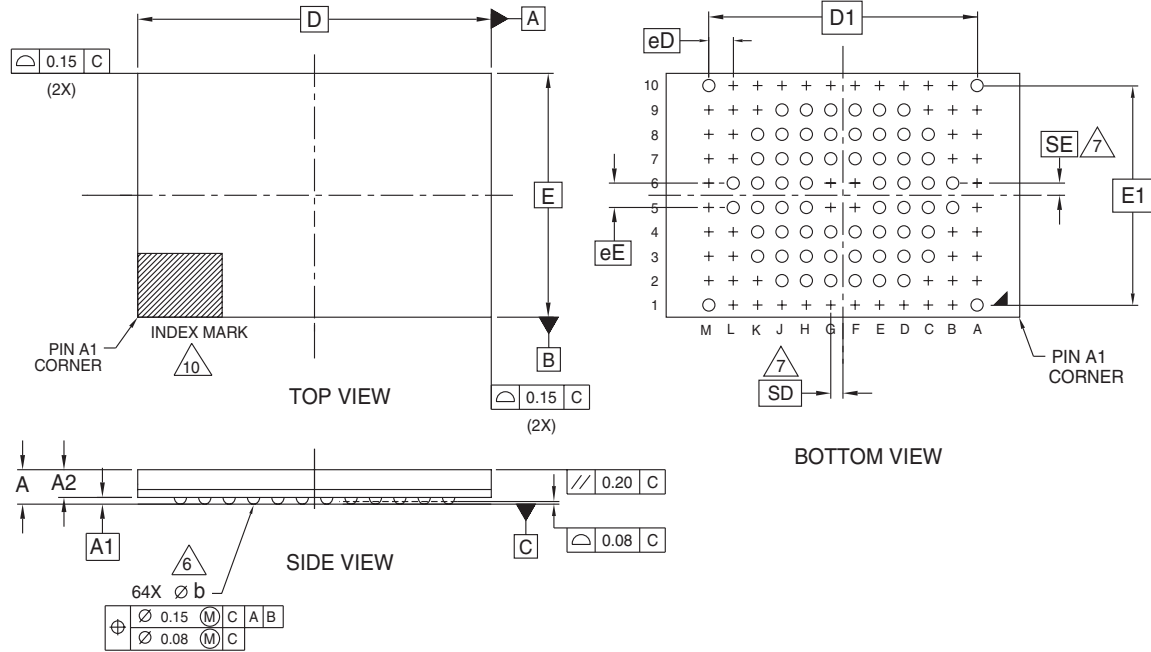

PACKAGE	TLA 064			
JEDEC	N/A			
D x E	11.60 mm x 8.00 mm PACKAGE			
SYMBOL	MIN	NOM	MAX	NOTE
A	---	---	1.20	PROFILE
A1	0.17	---	---	BALL HEIGHT
A2	0.81	---	0.97	BODY THICKNESS
D	11.60 BSC.			BODY SIZE
E	8.00 BSC.			BODY SIZE
D1	8.80 BSC.			MATRIX FOOTPRINT
E1	7.20 BSC.			MATRIX FOOTPRINT
MD	12			MATRIX SIZE D DIRECTION
ME	10			MATRIX SIZE E DIRECTION
n	64			BALL COUNT
φb	0.35	0.40	0.45	BALL DIAMETER
eE	0.80 BSC.			BALL PITCH
eD	0.80 BSC			BALL PITCH
SD / SE	0.40 BSC.			SOLDER BALL PLACEMENT
	A2, A3, A4, A5, A6, A7, A8, A9, B1, B2, B3, B4, B7, B8, B9, B10, C1, C2, C9, C10, D1, D10, E1, E10, F1, F5, F6, F10, G1, G5, G6, G10, H1, H10, J1, J10, K1, K2, K9, K10, L1, L2, L3, L4, L7, L8, L9, L10, M2, M3, M4, M5, M6, M7, M8, M9			DEPOPULATED SOLDER BALLS

NOTES:

- DIMENSIONING AND TOLERANCING METHODS PER ASME Y14.5M-1994.
- ALL DIMENSIONS ARE IN MILLIMETERS.
- BALL POSITION DESIGNATION PER JESD 95-1, SPP-010.
- [e] REPRESENTS THE SOLDER BALL GRID PITCH.
- SYMBOL "MD" IS THE BALL MATRIX SIZE IN THE "D" DIRECTION.  
SYMBOL "ME" IS THE BALL MATRIX SIZE IN THE "E" DIRECTION.  
n IS THE NUMBER OF POPULATED SOLDER BALL POSITIONS FOR MATRIX SIZE MD X ME.
- DIMENSION "b" IS MEASURED AT THE MAXIMUM BALL DIAMETER IN A PLANE PARALLEL TO DATUM C.
- SD AND SE ARE MEASURED WITH RESPECT TO DATUMS A AND B AND DEFINE THE POSITION OF THE CENTER SOLDER BALL IN THE OUTER ROW.  
WHEN THERE IS AN ODD NUMBER OF SOLDER BALLS IN THE OUTER ROW SD OR SE = 0.000.  
WHEN THERE IS AN EVEN NUMBER OF SOLDER BALLS IN THE OUTER ROW, SD OR SE = [e]/2
- "+" INDICATES THE THEORETICAL CENTER OF DEPOPULATED BALLS.
- N/A
- A1 CORNER TO BE IDENTIFIED BY CHAMFER, LASER OR INK MARK, METALLIZED MARK INDENTATION OR OTHER MEANS.

3352 \ 16-038.22a

**Note:** BSC is an ANSI standard for Basic Space Centering.

**S29GLxxxN MirrorBit™ Flash Family**  
**S29GL512N, S29GL256N, S29GL128N**  
512 Megabit, 256 Megabit, and 128 Megabit,  
3.0 Volt-only Page Mode Flash Memory featuring  
110 nm MirrorBit process technology



## Datasheet

**ADVANCE  
INFORMATION**

## Distinctive Characteristics

### Architectural Advantages

- **Single power supply operation**
  - 3 volt read, erase, and program operations
- **Enhanced VersatileI/O™ control**
  - All input levels (address, control, and DQ input levels) and outputs are determined by voltage on V<sub>IO</sub> input. V<sub>IO</sub> range is 1.65 to V<sub>CC</sub>
- **Manufactured on 110 nm MirrorBit process technology**
- **Secured Silicon Sector region**
  - 128-word/256-byte sector for permanent, secure identification through an 8-word/16-byte random Electronic Serial Number, accessible through a command sequence
  - May be programmed and locked at the factory or by the customer
- **Flexible sector architecture**
  - S29GL512N: Five hundred twelve 64 Kword (128 Kbyte) sectors
  - S29GL256N: Two hundred fifty-six 64 Kword (128 Kbyte) sectors
  - S29GL128N: One hundred twenty-eight 64 Kword (128 Kbyte) sectors
- **Compatibility with JEDEC standards**
  - Provides pinout and software compatibility for single-power supply flash, and superior inadvertent write protection
- **100,000 erase cycles per sector typical**
- **20-year data retention typical**

### Performance Characteristics

- **High performance**

- 80 ns access time (S29GL128N, S29GL256N), 90 ns access time (S29GL512N)
- 8-word/16-byte page read buffer
- 25 ns page read times
- 16-word/32-byte write buffer reduces overall programming time for multiple-word updates
- **Low power consumption (typical values at 3.0 V, 5 MHz)**
  - 25 mA typical active read current;
  - 50 mA typical erase/program current
  - 1 µA typical standby mode current

### Software & Hardware Features

- **Software features**
  - Program Suspend & Resume: read other sectors before programming operation is completed
  - Erase Suspend & Resume: read/program other sectors before an erase operation is completed
  - Data# polling & toggle bits provide status
  - Unlock Bypass Program command reduces overall multiple-word or byte programming time
  - CFI (Common Flash Interface) compliant: allows host system to identify and accommodate multiple flash devices
- **Hardware features**
  - Advanced Sector Protection
  - WP#/ACC input accelerates programming time (when high voltage is applied) for greater throughput during system production. Protects first or last sector regardless of sector protection settings
  - Hardware reset input (RESET#) resets device
  - Ready/Busy# output (RY/BY#) detects program or erase cycle completion

## General Description

The GL512/256/128N family of devices are 3.0V single power flash memory manufactured using 110 nm MirrorBit technology. The GL512N is a 512 Mbit, organized as 33,554,432 words or 67,108,864 bytes. The GL256N is a 256 Mbit, organized as 16,777,216 words or 33,554,432 bytes. The GL128N is a 128 Mbit, organized as 8,388,608 words or 16,777,216 bytes. The devices have a 16-bit wide data bus that can also function as an 8-bit wide data bus by using the BYTE# input. The device can be programmed either in the host system or in standard EPROM programmers.

Access times as fast as 90 ns (GL128N, GL256N) or 100 ns (GL512N) are available.

Each device requires only a **single 3.0 volt power supply** for both read and write functions. In addition to a  $V_{CC}$  input, a high-voltage **accelerated program (WP#/ACC)** input provides shorter programming times through increased current. This feature is intended to facilitate factory throughput during system production, but may also be used in the field if desired.

The devices are entirely command set compatible with the **JEDEC single-power-supply Flash standard**. Commands are written to the device using standard microprocessor write timing. Write cycles also internally latch addresses and data needed for the programming and erase operations.

The **sector erase architecture** allows memory sectors to be erased and reprogrammed without affecting the data contents of other sectors. The device is fully erased when shipped from the factory.

Device programming and erasure are initiated through command sequences. Once a program or erase operation has begun, the host system need only poll the DQ7 (Data# Polling) or DQ6 (toggle) **status bits** or monitor the **Ready/Busy# (RY/BY#)** output to determine whether the operation is complete. To facilitate programming, an **Unlock Bypass** mode reduces command sequence overhead by requiring only two write cycles to program data instead of four.

**Hardware data protection** measures include a low  $V_{CC}$  detector that automatically inhibits write operations during power transitions. **Persistent Sector Protection** provides in-system, command-enabled protection of any combination of sectors using a single power supply at  $V_{CC}$ . **Password Sector Protection** prevents unauthorized write and erase operations in any combination of sectors through a user-defined 64-bit password.

The **Erase Suspend/Erase Resume** feature allows the host system to pause an erase operation in a given sector to read or program any other sector and then complete the erase operation. The **Program Suspend/Program Resume** feature enables the host system to pause a program operation in a given sector to read any other sector and then complete the program operation.

The **hardware RESET# pin** terminates any operation in progress and resets the device, after which it is then ready for a new operation. The RESET# pin may be tied to the system reset circuitry. A system reset would thus also reset the device, enabling the host system to read boot-up firmware from the Flash memory device.

The device reduces power consumption in the **standby mode** when it detects specific voltage levels on CE# and RESET#, or when addresses have been stable for a specified period of time.

The **Secured Silicon Sector** provides a 128-word/256-byte area for code or data that can be permanently protected. Once this sector is protected, no further changes within the sector can occur.

The **Write Protect (WP#/ACC)** feature protects the first or last sector by asserting a logic low on the WP# pin.

MirrorBit flash technology combines years of Flash memory manufacturing experience to produce the highest levels of quality, reliability and cost effectiveness. The device electrically erases all bits within a sector simultaneously via hot-hole assisted erase. The data is programmed using hot electron injection.

### Block Diagram

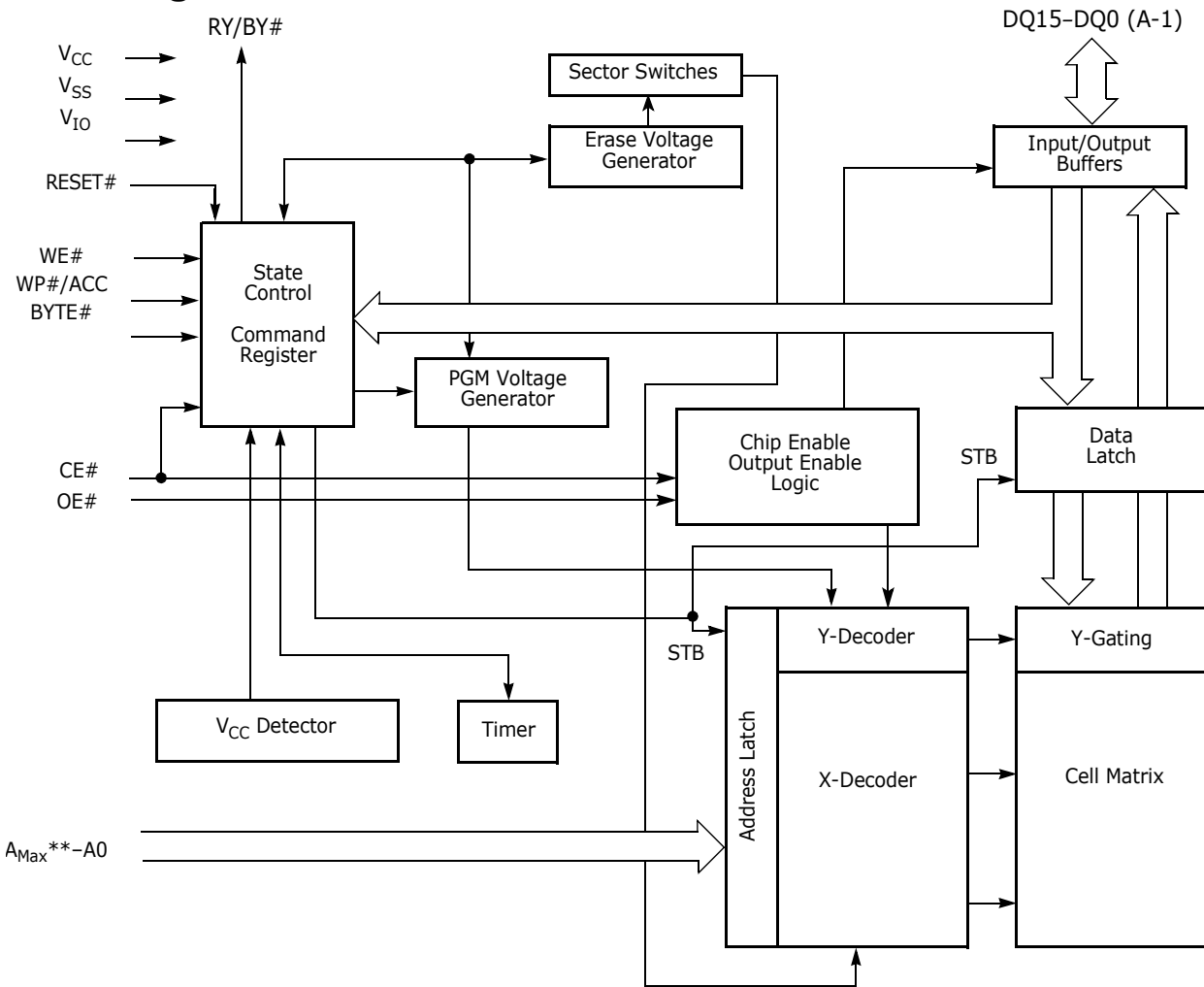

## Device Bus Operations

This section describes the requirements and use of the device bus operations, which are initiated through the internal command register. The command register itself does not occupy any addressable memory location. The register is a latch used to store the commands, along with the address and data information needed to execute the command. The contents of the register serve as inputs to the internal state machine. The state machine outputs dictate the function of the device. Table 1 lists the device bus operations, the inputs and control levels they require, and the resulting output. The following subsections describe each of these operations in further detail.

**Table 1. Device Bus Operations**

Operation	CE#	OE#	WE #	RESET#	WP#	ACC	Addresses (Note 2)	DQ0-DQ7	DQ8-DQ15	
									BYTE# = V <sub>IH</sub>	BYTE# = V <sub>IL</sub>
Read	L	L	H	H	X	X	A <sub>IN</sub>	D <sub>OUT</sub>	D <sub>OUT</sub>	DQ8-DQ14 = High-Z, DQ15 = A-1
Write (Program/Erase)	L	H	L	H	(Note 2)	X	A <sub>IN</sub>	(Note 3)	(Note 3)	
Accelerated Program	L	H	L	H	(Note 2)	V <sub>HH</sub>	A <sub>IN</sub>	(Note 3)	(Note 3)	
Standby	V <sub>CC</sub> ± 0.3 V	X	X	V <sub>CC</sub> ± 0.3 V	X	H	X	High-Z	High-Z	High-Z
Output Disable	L	H	H	H	X	X	X	High-Z	High-Z	High-Z
Reset	X	X	X	L	X	X	X	High-Z	High-Z	High-Z

**Legend:** L = Logic Low = V<sub>IL</sub>, H = Logic High = V<sub>IH</sub>, V<sub>ID</sub> = 11.5–12.5 V, V<sub>HH</sub> = 11.5–12.5V, X = Don't Care, SA = Sector Address, A<sub>IN</sub> = Address In, D<sub>IN</sub> = Data In, D<sub>OUT</sub> = Data Out

**Notes:**

- Addresses are A<sub>Max</sub>:A0 in word mode; A<sub>Max</sub>:A-1 in byte mode. Sector addresses are A<sub>Max</sub>:A16 in both modes.
- If WP# = V<sub>IL</sub>, the first or last sector group remains protected. If WP# = V<sub>IH</sub>, the first or last sector will be protected or unprotected as determined by the method described in "Write Protect (WP#)". All sectors are unprotected when shipped from the factory (The Secured Silicon Sector may be factory protected depending on version ordered.)
- D<sub>IN</sub> or D<sub>OUT</sub> as required by command sequence, data polling, or sector protect algorithm (see Figure 2).

### Word/Byte Configuration

The BYTE# pin controls whether the device data I/O pins operate in the byte or word configuration. If the BYTE# pin is set at logic '1', the device is in word configuration, DQ0–DQ15 are active and controlled by CE# and OE#.

If the BYTE# pin is set at logic '0', the device is in byte configuration, and only data I/O pins DQ0–DQ7 are active and controlled by CE# and OE#. The data I/O pins DQ8–DQ14 are tri-stated, and the DQ15 pin is used as an input for the LSB (A-1) address function.

### Requirements for Reading Array Data

To read array data from the outputs, the system must drive the CE# and OE# pins to V<sub>IL</sub>. CE# is the power control and selects the device. OE# is the output control and gates array data to the output pins. WE# should remain at V<sub>IH</sub>.

The internal state machine is set for reading array data upon device power-up, or after a hardware reset. This ensures that no spurious alteration of the memory content occurs during the power transition. No command is necessary in this mode to obtain array data. Standard microprocessor read cycles that assert valid addresses on the device address inputs produce valid data on the device data outputs. The device remains enabled for read access until the command register contents are altered.

See “Reading Array Data” for more information. Refer to the AC Read-Only Operations table for timing specifications and to Figure 11 for the timing diagram. Refer to the DC Characteristics table for the active current specification on reading array data.

### Page Mode Read

The device is capable of fast page mode read and is compatible with the page mode Mask ROM read operation. This mode provides faster read access speed for random locations within a page. The page size of the device is 8 words/16 bytes. The appropriate page is selected by the higher address bits A(max)–A3. Address bits A2–A0 in word mode (A2–A-1 in byte mode) determine the specific word within a page. This is an asynchronous operation; the microprocessor supplies the specific word location.

The random or initial page access is equal to  $t_{ACC}$  or  $t_{CE}$  and subsequent page read accesses (as long as the locations specified by the microprocessor falls within that page) is equivalent to  $t_{PACC}$ . When CE# is de-asserted and reasserted for a subsequent access, the access time is  $t_{ACC}$  or  $t_{CE}$ . Fast page mode accesses are obtained by keeping the “read-page addresses” constant and changing the “intra-read page” addresses.

## Writing Commands/Command Sequences

To write a command or command sequence (which includes programming data to the device and erasing sectors of memory), the system must drive WE# and CE# to  $V_{IL}$ , and OE# to  $V_{IH}$ .

The device features an **Unlock Bypass** mode to facilitate faster programming. Once the device enters the Unlock Bypass mode, only two write cycles are required to program a word or byte, instead of four. The “Word/Byte Program Command Sequence” section has details on programming data to the device using both standard and Unlock Bypass command sequences.

An erase operation can erase one sector, multiple sectors, or the entire device. Table 2 indicates the address space that each sector occupies.

Refer to the DC Characteristics table for the active current specification for the write mode. The AC Characteristics section contains timing specification tables and timing diagrams for write operations.

### Write Buffer

Write Buffer Programming allows the system write to a maximum of 16 words/32 bytes in one programming operation. This results in faster effective programming time than the standard programming algorithms. See “Write Buffer” for more information.



## Accelerated Program Operation

The device offers accelerated program operations through the ACC function. This is one of two functions provided by the WP#/ACC pin. This function is primarily intended to allow faster manufacturing throughput at the factory.

If the system asserts  $V_{HH}$  on this pin, the device automatically enters the aforementioned Unlock Bypass mode, temporarily unprotects any protected sector groups, and uses the higher voltage on the pin to reduce the time required for program operations. The system would use a two-cycle program command sequence as required by the Unlock Bypass mode. Removing  $V_{HH}$  from the WP#/ACC pin returns the device to normal operation. *Note that the WP#/ACC pin must not be at  $V_{HH}$  for operations other than accelerated programming, or device damage may result. WP# has an internal pullup; when unconnected, WP# is at  $V_{IH}$ .*

## Autoselect Functions

If the system writes the autoselect command sequence, the device enters the autoselect mode. The system can then read autoselect codes from the internal register (which is separate from the memory array) on DQ7–DQ0. Standard read cycle timings apply in this mode. Refer to the “Autoselect Command Sequence” section on page 50 sections for more information.

## Standby Mode

When the system is not reading or writing to the device, it can place the device in the standby mode. In this mode, current consumption is greatly reduced, and the outputs are placed in the high impedance state, independent of the OE# input.

The device enters the CMOS standby mode when the CE# and RESET# pins are both held at  $V_{IO} \pm 0.3$  V. (Note that this is a more restricted voltage range than  $V_{IH}$ .) If CE# and RESET# are held at  $V_{IH}$ , but not within  $V_{IO} \pm 0.3$  V, the device will be in the standby mode, but the standby current will be greater. The device requires standard access time ( $t_{CE}$ ) for read access when the device is in either of these standby modes, before it is ready to read data.

If the device is deselected during erasure or programming, the device draws active current until the operation is completed.

Refer to the “DC Characteristics” section on page 78 for the standby current specification.

## Automatic Sleep Mode

The automatic sleep mode minimizes Flash device energy consumption. The device automatically enables this mode when addresses remain stable for  $t_{ACC} + 30$  ns. The automatic sleep mode is independent of the CE#, WE#, and OE# control signals. Standard address access timings provide new data when addresses are changed. While in sleep mode, output data is latched and always available to the system. Refer to the “DC Characteristics” section on page 78 for the automatic sleep mode current specification.

## RESET#: Hardware Reset Pin

The RESET# pin provides a hardware method of resetting the device to reading array data. When the RESET# pin is driven low for at least a period of  $t_{RP}$ , the device immediately terminates any operation in progress, tristates all output pins, and ignores all read/write commands for the duration of the RESET# pulse. The device also resets the internal state machine to reading array data. The op-

eration that was interrupted should be reinitiated once the device is ready to accept another command sequence, to ensure data integrity.

Current is reduced for the duration of the RESET# pulse. When RESET# is held at  $V_{SS} \pm 0.3$  V, the device draws CMOS standby current ( $I_{CC5}$ ). If RESET# is held at  $V_{IL}$  but not within  $V_{SS} \pm 0.3$  V, the standby current will be greater.

The RESET# pin may be tied to the system reset circuitry. A system reset would thus also reset the Flash memory, enabling the system to read the boot-up firm-ware from the Flash memory.

Refer to the AC Characteristics tables for RESET# parameters and to Figure 13 for the timing diagram.

### Output Disable Mode

When the OE# input is at  $V_{IH}$ , output from the device is disabled. The output pins are placed in the high impedance state.

**Table 2. Sector Address Table—S29GL256N**

Sector	A23–A16								Sector Size (Kbytes/ Kwords)	8-bit Address Range (in hexadecimal)	16-bit Address Range (in hexadecimal)
	A23	A22	A21	A20	A19	A18	A17	A16			
SA0	0	0	0	0	0	0	0	0	128/64	0000000–001FFFF	0000000–000FFFF
SA1	0	0	0	0	0	0	0	1	128/64	0020000–003FFFF	0010000–001FFFF
SA2	0	0	0	0	0	0	1	0	128/64	0040000–005FFFF	0020000–002FFFF
SA3	0	0	0	0	0	0	1	1	128/64	0060000–007FFFF	0030000–003FFFF
SA4	0	0	0	0	0	1	0	0	128/64	0080000–009FFFF	0040000–004FFFF
SA5	0	0	0	0	0	1	0	1	128/64	00A0000–00BFFFF	0050000–005FFFF
SA6	0	0	0	0	0	1	1	0	128/64	00C0000–00DFFFF	0060000–006FFFF
SA7	0	0	0	0	0	1	1	1	128/64	00E0000–00FFFFFF	0070000–007FFFF
SA8	0	0	0	0	1	0	0	0	128/64	0100000–011FFFF	0080000–008FFFF
SA9	0	0	0	0	1	0	0	1	128/64	0120000–013FFFF	0090000–009FFFF
SA10	0	0	0	0	1	0	1	0	128/64	0140000–015FFFF	00A0000–00AFFFF
SA11	0	0	0	0	1	0	1	1	128/64	0160000–017FFFF	00B0000–00BFFFF
SA12	0	0	0	0	1	1	0	0	128/64	0180000–019FFFF	00C0000–00CFFFF
SA13	0	0	0	0	1	1	0	1	128/64	01A0000–01BFFFF	00D0000–00DFFFF
SA14	0	0	0	0	1	1	1	0	128/64	01C0000–01DFFFF	00E0000–00EFFFF
SA15	0	0	0	0	1	1	1	1	128/64	01E0000–01FFFFFF	00F0000–00FFFFFF
SA16	0	0	0	1	0	0	0	0	128/64	0200000–021FFFF	0100000–010FFFF
SA17	0	0	0	1	0	0	0	1	128/64	0220000–023FFFF	0110000–011FFFF
SA18	0	0	0	1	0	0	1	0	128/64	0240000–025FFFF	0120000–012FFFF
SA19	0	0	0	1	0	0	1	1	128/64	0260000–027FFFF	0130000–013FFFF
SA20	0	0	0	1	0	1	0	0	128/64	0280000–029FFFF	0140000–014FFFF
SA21	0	0	0	1	0	1	0	1	128/64	02A0000–02BFFFF	0150000–015FFFF
SA22	0	0	0	1	0	1	1	0	128/64	02C0000–02DFFFF	0160000–016FFFF

Table 2. Sector Address Table–S29GL256N (Continued)

Sector	A23–A16								Sector Size (Kbytes/ Kwords)	8-bit Address Range (in hexadecimal)	16-bit Address Range (in hexadecimal)
	0	0	0	1	0	1	1	1			
SA23	0	0	0	1	0	1	1	1	128/64	02E0000–02FFFFFF	0170000–017FFFF
SA24	0	0	0	1	1	0	0	0	128/64	0300000–031FFFF	0180000–018FFFF
SA25	0	0	0	1	1	0	0	1	128/64	0320000–033FFFF	0190000–019FFFF
SA26	0	0	0	1	1	0	1	0	128/64	0340000–035FFFF	01A0000–01AFFFF
SA27	0	0	0	1	1	0	1	1	128/64	0360000–037FFFF	01B0000–01BFFFF
SA28	0	0	0	1	1	1	0	0	128/64	0380000–039FFFF	01C0000–01CFFFF
SA29	0	0	0	1	1	1	0	1	128/64	03A0000–03BFFFF	01D0000–01DFFFF
SA30	0	0	0	1	1	1	1	0	128/64	03C0000–03DFFFF	01E0000–01EFFFF
SA31	0	0	0	1	1	1	1	1	128/64	03E0000–03FFFFFF	01F0000–01FFFFFF
SA32	0	0	1	0	0	0	0	0	128/64	0400000–041FFFF	0200000–020FFFF
SA33	0	0	1	0	0	0	0	1	128/64	0420000–043FFFF	0210000–021FFFF
SA34	0	0	1	0	0	0	1	0	128/64	0440000–045FFFF	0220000–022FFFF
SA35	0	0	1	0	0	0	1	1	128/64	0460000–047FFFF	0230000–023FFFF
SA36	0	0	1	0	0	1	0	0	128/64	0480000–049FFFF	0240000–024FFFF
SA37	0	0	1	0	0	1	0	1	128/64	04A0000–04BFFFF	0250000–025FFFF
SA38	0	0	1	0	0	1	1	0	128/64	04C0000–04DFFFF	0260000–026FFFF
SA39	0	0	1	0	0	1	1	1	128/64	04E0000–04FFFFFF	0270000–027FFFF
SA40	0	0	1	0	1	0	0	0	128/64	0500000–051FFFF	0280000–028FFFF
SA41	0	0	1	0	1	0	0	1	128/64	0520000–053FFFF	0290000–029FFFF
SA42	0	0	1	0	1	0	1	0	128/64	0540000–055FFFF	02A0000–02AFFFF
SA43	0	0	1	0	1	0	1	1	128/64	0560000–057FFFF	02B0000–02BFFFF
SA44	0	0	1	0	1	1	0	0	128/64	0580000–059FFFF	02C0000–02CFFFF
SA45	0	0	1	0	1	1	0	1	128/64	05A0000–05BFFFF	02D0000–02DFFFF
SA46	0	0	1	0	1	1	1	0	128/64	05C0000–05DFFFF	02E0000–02EFFFF
SA47	0	0	1	0	1	1	1	1	128/64	05E0000–05FFFFFF	02F0000–02FFFFFF
SA48	0	0	1	1	0	0	0	0	128/64	0600000–061FFFF	0300000–030FFFF
SA49	0	0	1	1	0	0	0	1	128/64	0620000–063FFFF	0310000–031FFFF
SA50	0	0	1	1	0	0	1	0	128/64	0640000–065FFFF	0320000–032FFFF
SA51	0	0	1	1	0	0	1	1	128/64	0660000–067FFFF	0330000–033FFFF
SA52	0	0	1	1	0	1	0	0	128/64	0680000–069FFFF	0340000–034FFFF
SA53	0	0	1	1	0	1	0	1	128/64	06A0000–06BFFFF	0350000–035FFFF
SA54	0	0	1	1	0	1	1	0	128/64	06C0000–06DFFFF	0360000–036FFFF
SA55	0	0	1	1	0	1	1	1	128/64	06E0000–06FFFFFF	0370000–037FFFF
SA56	0	0	1	1	1	0	0	0	128/64	0700000–071FFFF	0380000–038FFFF
SA57	0	0	1	1	1	0	0	1	128/64	0720000–073FFFF	0390000–039FFFF

**Table 2. Sector Address Table–S29GL256N (Continued)**

Sector	A23–A16								Sector Size (Kbytes/ Kwords)	8-bit Address Range (in hexadecimal)	16-bit Address Range (in hexadecimal)
	0	0	1	1	1	0	1	0			
SA58	0	0	1	1	1	0	1	0	128/64	0740000–075FFFF	03A0000–03AFFFF
SA59	0	0	1	1	1	0	1	1	128/64	0760000–077FFFF	03B0000–03BFFFF
SA60	0	0	1	1	1	1	0	0	128/64	0780000–079FFFF	03C0000–03CFFFF
SA61	0	0	1	1	1	1	0	1	128/64	07A0000–07BFFFF	03D0000–03DFFFF
SA62	0	0	1	1	1	1	1	0	128/64	07C0000–07DFFFF	03E0000–03EFFFF
SA63	0	0	1	1	1	1	1	1	128/64	07E0000–07FFFFFF0	03F0000–03FFFFFFF
SA64	0	1	0	0	0	0	0	0	128/64	0800000–081FFFF	0400000–040FFFF
SA65	0	1	0	0	0	0	0	1	128/64	0820000–083FFFF	0410000–041FFFF
SA66	0	1	0	0	0	0	1	0	128/64	0840000–085FFFF	0420000–042FFFF
SA67	0	1	0	0	0	0	1	1	128/64	0860000–087FFFF	0430000–043FFFF
SA68	0	1	0	0	0	1	0	0	128/64	0880000–089FFFF	0440000–044FFFF
SA69	0	1	0	0	0	1	0	1	128/64	08A0000–08BFFFF	0450000–045FFFF
SA70	0	1	0	0	0	1	1	0	128/64	08C0000–08DFFFF	0460000–046FFFF
SA71	0	1	0	0	0	1	1	1	128/64	08E0000–08FFFFFFF	0470000–047FFFF
SA72	0	1	0	0	1	0	0	0	128/64	0900000–091FFFF	0480000–048FFFF
SA73	0	1	0	0	1	0	0	1	128/64	0920000–093FFFF	0490000–049FFFF
SA74	0	1	0	0	1	0	1	0	128/64	0940000–095FFFF	04A0000–04AFFFF
SA75	0	1	0	0	1	0	1	1	128/64	0960000–097FFFF	04B0000–04BFFFF
SA76	0	1	0	0	1	1	0	0	128/64	0980000–099FFFF	04C0000–04CFFFF
SA77	0	1	0	0	1	1	0	1	128/64	09A0000–09BFFFF	04D0000–04DFFFF
SA78	0	1	0	0	1	1	1	0	128/64	09C0000–09DFFFF	04E0000–04EFFFF
SA79	0	1	0	0	1	1	1	1	128/64	09E0000–09FFFFFFF	04F0000–04FFFFFFF
SA80	0	1	0	1	0	0	0	0	128/64	0A00000–0A1FFFF	0500000–050FFFF
SA81	0	1	0	1	0	0	0	1	128/64	0A20000–0A3FFFF	0510000–051FFFF
SA82	0	1	0	1	0	0	1	0	128/64	0A40000–0A5FFFF	0520000–052FFFF
SA83	0	1	0	1	0	0	1	1	128/64	0A60000–0A7FFFF	0530000–053FFFF
SA84	0	1	0	1	0	1	0	0	128/64	0A80000–0A9FFFF	0540000–054FFFF
SA85	0	1	0	1	0	1	0	1	128/64	0AA0000–0ABFFFF	0550000–055FFFF
SA86	0	1	0	1	0	1	1	0	128/64	0AC0000–0ADFFFF	0560000–056FFFF
SA87	0	1	0	1	0	1	1	1	128/64	0AE0000–AEFFFFFFF	0570000–057FFFF
SA88	0	1	0	1	1	0	0	0	128/64	0B00000–0B1FFFF	0580000–058FFFF
SA89	0	1	0	1	1	0	0	1	128/64	0B20000–0B3FFFF	0590000–059FFFF
SA90	0	1	0	1	1	0	1	0	128/64	0B40000–0B5FFFF	05A0000–05AFFFF
SA91	0	1	0	1	1	0	1	1	128/64	0B60000–0B7FFFF	05B0000–05BFFFF
SA92	0	1	0	1	1	1	0	0	128/64	0B80000–0B9FFFF	05C0000–05CFFFF

Table 2. Sector Address Table–S29GL256N (Continued)

Sector	A23–A16								Sector Size (Kbytes/ Kwords)	8-bit Address Range (in hexadecimal)	16-bit Address Range (in hexadecimal)
	0	1	0	1	1	1	0	1			
SA93	0	1	0	1	1	1	0	1	128/64	0BA0000–0BBFFFF	05D0000–05DFFFF
SA94	0	1	0	1	1	1	1	0	128/64	0BC0000–0BDFFFF	05E0000–05EFFFF
SA95	0	1	0	1	1	1	1	1	128/64	0BE0000–0BFFFFF	05F0000–05FFFFF
SA96	0	1	1	0	0	0	0	0	128/64	0C00000–0C1FFFF	0600000–060FFFF
SA97	0	1	1	0	0	0	0	1	128/64	0C20000–0C3FFFF	0610000–061FFFF
SA98	0	1	1	0	0	0	1	0	128/64	0C40000–0C5FFFF	0620000–062FFFF
SA99	0	1	1	0	0	0	1	1	128/64	0C60000–0C7FFFF	0630000–063FFFF
SA100	0	1	1	0	0	1	0	0	128/64	0C80000–0C9FFFF	0640000–064FFFF
SA101	0	1	1	0	0	1	0	1	128/64	0CA0000–0CBFFFF	0650000–065FFFF
SA102	0	1	1	0	0	1	1	0	128/64	0CC0000–0CDFFFF	0660000–066FFFF
SA103	0	1	1	0	0	1	1	1	128/64	0CE0000–0CFFFFF	0670000–067FFFF
SA104	0	1	1	0	1	0	0	0	128/64	0D00000–0D1FFFF	0680000–068FFFF
SA105	0	1	1	0	1	0	0	1	128/64	0D20000–0D3FFFF	0690000–069FFFF
SA106	0	1	1	0	1	0	1	0	128/64	0D40000–0D5FFFF	06A0000–06AFFFF
SA107	0	1	1	0	1	0	1	1	128/64	0D60000–0D7FFFF	06B0000–06BFFFF
SA108	0	1	1	0	1	1	0	0	128/64	0D80000–0D9FFFF	06C0000–06CFFFF
SA109	0	1	1	0	1	1	0	1	128/64	0DA0000–0DBFFFF	06D0000–06DFFFF
SA110	0	1	1	0	1	1	1	0	128/64	0DC0000–0DDFFFF	06E0000–06EFFFF
SA111	0	1	1	0	1	1	1	1	128/64	0DE0000–0DFFFFF	06F0000–06FFFFF
SA112	0	1	1	1	0	0	0	0	128/64	0E00000–0E1FFFF	0700000–070FFFF
SA113	0	1	1	1	0	0	0	1	128/64	0E20000–0E3FFFF	0710000–071FFFF
SA114	0	1	1	1	0	0	1	0	128/64	0E40000–0E5FFFF	0720000–072FFFF
SA115	0	1	1	1	0	0	1	1	128/64	0E60000–0E7FFFF	0730000–073FFFF
SA116	0	1	1	1	0	1	0	0	128/64	0E80000–0E9FFFF	0740000–074FFFF
SA117	0	1	1	1	0	1	0	1	128/64	0EA0000–0EBFFFF	0750000–075FFFF
SA118	0	1	1	1	0	1	1	0	128/64	0EC0000–0EDFFFF	0760000–076FFFF
SA119	0	1	1	1	0	1	1	1	128/64	0EE0000–0EEFFFF	0770000–077FFFF
SA120	0	1	1	1	1	0	0	0	128/64	0F00000–0F1FFFF	0780000–078FFFF
SA121	0	1	1	1	1	0	0	1	128/64	0F20000–0F3FFFF	0790000–079FFFF
SA122	0	1	1	1	1	0	1	0	128/64	0F40000–0F5FFFF	07A0000–07AFFFF
SA123	0	1	1	1	1	0	1	1	128/64	0F60000–0F7FFFF	07B0000–07BFFFF
SA124	0	1	1	1	1	1	0	0	128/64	0F80000–0F9FFFF	07C0000–07CFFFF
SA125	0	1	1	1	1	1	0	1	128/64	0FA0000–0FBFFFF	07D0000–07DFFFF
SA126	0	1	1	1	1	1	1	0	128/64	0FC0000–0FDFFFF	07E0000–07EFFFF
SA127	0	1	1	1	1	1	1	1	128/64	0FE0000–0FFFFFF	07F0000–07FFFFF

**Table 2. Sector Address Table–S29GL256N (Continued)**

Sector	A23–A16								Sector Size (Kbytes/ Kwords)	8-bit Address Range (in hexadecimal)	16-bit Address Range (in hexadecimal)
	1	0	0	0	0	0	0	0			
SA128	1	0	0	0	0	0	0	0	128/64	1000000–101FFFF	0800000–080FFFF
SA129	1	0	0	0	0	0	0	1	128/64	1020000–103FFFF	0810000–081FFFF
SA130	1	0	0	0	0	0	1	0	128/64	1040000–105FFFF	0820000–082FFFF
SA131	1	0	0	0	0	0	1	1	128/64	1060000–107FFFF	0830000–083FFFF
SA132	1	0	0	0	0	1	0	0	128/64	1080000–109FFFF	0840000–084FFFF
SA133	1	0	0	0	0	1	0	1	128/64	10A0000–10BFFFF	0850000–085FFFF
SA134	1	0	0	0	0	1	1	0	128/64	10C0000–10DFFFF	0860000–086FFFF
SA135	1	0	0	0	0	1	1	1	128/64	10E0000–10FFFFFF	0870000–087FFFF
SA136	1	0	0	0	1	0	0	0	128/64	1100000–111FFFF	0880000–088FFFF
SA137	1	0	0	0	1	0	0	1	128/64	1120000–113FFFF	0890000–089FFFF
SA138	1	0	0	0	1	0	1	0	128/64	1140000–115FFFF	08A0000–08AFFFF
SA139	1	0	0	0	1	0	1	1	128/64	1160000–117FFFF	08B0000–08BFFFF
SA140	1	0	0	0	1	1	0	0	128/64	1180000–119FFFF	08C0000–08CFFFF
SA141	1	0	0	0	1	1	0	1	128/64	11A0000–11BFFFF	08D0000–08DFFFF
SA142	1	0	0	0	1	1	1	0	128/64	11C0000–11DFFFF	08E0000–08EFFFF
SA143	1	0	0	0	1	1	1	1	128/64	11E0000–11FFFFFF	08F0000–08FFFFFF
SA144	1	0	0	1	0	0	0	0	128/64	1200000–121FFFF	0900000–090FFFF
SA145	1	0	0	1	0	0	0	1	128/64	1220000–123FFFF	0910000–091FFFF
SA146	1	0	0	1	0	0	1	0	128/64	1240000–125FFFF	0920000–092FFFF
SA147	1	0	0	1	0	0	1	1	128/64	1260000–127FFFF	0930000–093FFFF
SA148	1	0	0	1	0	1	0	0	128/64	1280000–129FFFF	0940000–094FFFF
SA149	1	0	0	1	0	1	0	1	128/64	12A0000–12BFFFF	0950000–095FFFF
SA150	1	0	0	1	0	1	1	0	128/64	12C0000–12DFFFF	0960000–096FFFF
SA151	1	0	0	1	0	1	1	1	128/64	12E0000–12FFFFFF	0970000–097FFFF
SA152	1	0	0	1	1	0	0	0	128/64	1300000–131FFFF	0980000–098FFFF
SA153	1	0	0	1	1	0	0	1	128/64	1320000–133FFFF	0990000–099FFFF
SA154	1	0	0	1	1	0	1	0	128/64	1340000–135FFFF	09A0000–09AFFFF
SA155	1	0	0	1	1	0	1	1	128/64	1360000–137FFFF	09B0000–09BFFFF
SA156	1	0	0	1	1	1	0	0	128/64	1380000–139FFFF	09C0000–09CFFFF
SA157	1	0	0	1	1	1	0	1	128/64	13A0000–13BFFFF	09D0000–09DFFFF
SA158	1	0	0	1	1	1	1	0	128/64	13C0000–13DFFFF	09E0000–09EFFFF
SA159	1	0	0	1	1	1	1	1	128/64	13E0000–13FFFFFF	09F0000–09FFFFFF
SA160	1	0	1	0	0	0	0	0	128/64	1400000–141FFFF	0A00000–0A0FFFF
SA161	1	0	1	0	0	0	0	1	128/64	1420000–143FFFF	0A10000–0A1FFFF
SA162	1	0	1	0	0	0	1	0	128/64	1440000–145FFFF	0A20000–0A2FFFF

**Table 2. Sector Address Table–S29GL256N (Continued)**

Sector	A23–A16								Sector Size (Kbytes/ Kwords)	8-bit Address Range (in hexadecimal)	16-bit Address Range (in hexadecimal)
	1	0	1	0	0	0	1	1			
SA163	1	0	1	0	0	0	1	1	128/64	1460000–147FFFF	0A30000–0A3FFFF
SA164	1	0	1	0	0	1	0	0	128/64	1480000–149FFFF	0A40000–0A4FFFF
SA165	1	0	1	0	0	1	0	1	128/64	14A0000–14BFFFF	0A50000–0A5FFFF
SA166	1	0	1	0	0	1	1	0	128/64	14C0000–14DFFFF	0A60000–0A6FFFF
SA167	1	0	1	0	0	1	1	1	128/64	14E0000–14FFFFFF	0A70000–0A7FFFF
SA168	1	0	1	0	1	0	0	0	128/64	1500000–151FFFF	0A80000–0A8FFFF
SA169	1	0	1	0	1	0	0	1	128/64	1520000–153FFFF	0A90000–0A9FFFF
SA170	1	0	1	0	1	0	1	0	128/64	1540000–155FFFF	0AA0000–0AAFFFF
SA171	1	0	1	0	1	0	1	1	128/64	1560000–157FFFF	0AB0000–0ABFFFF
SA172	1	0	1	0	1	1	0	0	128/64	1580000–159FFFF	0AC0000–0ACFFFF
SA173	1	0	1	0	1	1	0	1	128/64	15A0000–15BFFFF	0AD0000–0ADFFFF
SA174	1	0	1	0	1	1	1	0	128/64	15C0000–15DFFFF	0AE0000–0AEFFFF
SA175	1	0	1	0	1	1	1	1	128/64	15E0000–15FFFFFF	0AF0000–0AFFFFFF
SA176	1	0	1	1	0	0	0	0	128/64	1600000–161FFFF	0B00000–0B0FFFF
SA177	1	0	1	1	0	0	0	1	128/64	1620000–163FFFF	0B10000–0B1FFFF
SA178	1	0	1	1	0	0	1	0	128/64	1640000–165FFFF	0B20000–0B2FFFF
SA179	1	0	1	1	0	0	1	1	128/64	1660000–167FFFF	0B30000–0B3FFFF
SA180	1	0	1	1	0	1	0	0	128/64	1680000–169FFFF	0B40000–0B4FFFF
SA181	1	0	1	1	0	1	0	1	128/64	16A0000–16BFFFF	0B50000–0B5FFFF
SA182	1	0	1	1	0	1	1	0	128/64	16C0000–16DFFFF	0B60000–0B6FFFF
SA183	1	0	1	1	0	1	1	1	128/64	16E0000–16FFFFFF	0B70000–0B7FFFF
SA184	1	0	1	1	1	0	0	0	128/64	1700000–171FFFF	0B80000–0B8FFFF
SA185	1	0	1	1	1	0	0	1	128/64	1720000–173FFFF	0B90000–0B9FFFF
SA186	1	0	1	1	1	0	1	0	128/64	1740000–175FFFF	0BA0000–0BAFFFF
SA187	1	0	1	1	1	0	1	1	128/64	1760000–177FFFF	0BB0000–0BBFFFF
SA188	1	0	1	1	1	1	0	0	128/64	1780000–179FFFF	0BC0000–0BCFFFF
SA189	1	0	1	1	1	1	0	1	128/64	17A0000–17BFFFF	0BD0000–0BDFFFF
SA190	1	0	1	1	1	1	1	0	128/64	17C0000–17DFFFF	0BE0000–0BEFFFF
SA191	1	0	1	1	1	1	1	1	128/64	17E0000–17FFFFFF	0BF0000–0BFFFFFF
SA192	1	1	0	0	0	0	0	0	128/64	1800000–181FFFF	0C00000–0C0FFFF
SA193	1	1	0	0	0	0	0	1	128/64	1820000–183FFFF	0C10000–0C1FFFF
SA194	1	1	0	0	0	0	1	0	128/64	1840000–185FFFF	0C20000–0C2FFFF
SA195	1	1	0	0	0	0	1	1	128/64	1860000–187FFFF	0C30000–0C3FFFF
SA196	1	1	0	0	0	1	0	0	128/64	1880000–189FFFF	0C40000–0C4FFFF
SA197	1	1	0	0	0	1	0	1	128/64	18A0000–18BFFFF	0C50000–0C5FFFF

**Table 2. Sector Address Table–S29GL256N (Continued)**

Sector	A23–A16								Sector Size (Kbytes/ Kwords)	8-bit Address Range (in hexadecimal)	16-bit Address Range (in hexadecimal)
SA198	1	1	0	0	0	1	1	0	128/64	18C0000–18DFFFF	0C60000–0C6FFFF
SA199	1	1	0	0	0	1	1	1	128/64	18E0000–18FFFFFF	0C70000–0C7FFFF
SA200	1	1	0	0	1	0	0	0	128/64	1900000–191FFFF	0C80000–0C8FFFF
SA201	1	1	0	0	1	0	0	1	128/64	1920000–193FFFF	0C90000–0C9FFFF
SA202	1	1	0	0	1	0	1	0	128/64	1940000–195FFFF	0CA0000–0CAFFFF
SA203	1	1	0	0	1	0	1	1	128/64	1960000–197FFFF	0CB0000–0CBFFFF
SA204	1	1	0	0	1	1	0	0	128/64	1980000–199FFFF	0CC0000–0CCFFFF
SA205	1	1	0	0	1	1	0	1	128/64	19A0000–19BFFFF	0CD0000–0CDFFFF
SA206	1	1	0	0	1	1	1	0	128/64	19C0000–19DFFFF	0CE0000–0CEFFFF
SA207	1	1	0	0	1	1	1	1	128/64	19E0000–19FFFF	0CF0000–0CFFFFFF
SA208	1	1	0	1	0	0	0	0	128/64	1A00000–1A1FFFF	0D00000–0D0FFFF
SA209	1	1	0	1	0	0	0	1	128/64	1A20000–1A3FFFF	0D10000–0D1FFFF
SA210	1	1	0	1	0	0	1	0	128/64	1A40000–1A5FFFF	0D20000–0D2FFFF
SA211	1	1	0	1	0	0	1	1	128/64	1A60000–1A7FFFF	0D30000–0D3FFFF
SA212	1	1	0	1	0	1	0	0	128/64	1A80000–1A9FFFF	0D40000–0D4FFFF
SA213	1	1	0	1	0	1	0	1	128/64	1AA0000–1ABFFFF	0D50000–0D5FFFF
SA214	1	1	0	1	0	1	1	0	128/64	1AC0000–1ADFFFF	0D60000–0D6FFFF
SA215	1	1	0	1	0	1	1	1	128/64	1AE0000–1AFFFFF	0D70000–0D7FFFF
SA216	1	1	0	1	1	0	0	0	128/64	1B00000–1B1FFFF	0D80000–0D8FFFF
SA217	1	1	0	1	1	0	0	1	128/64	1B20000–1B3FFFF	0D90000–0D9FFFF
SA218	1	1	0	1	1	0	1	0	128/64	1B40000–1B5FFFF	0DA0000–0DAFFFF
SA219	1	1	0	1	1	0	1	1	128/64	1B60000–1B7FFFF	0DB0000–0DBFFFF
SA220	1	1	0	1	1	1	0	0	128/64	1B80000–1B9FFFF	0DC0000–0DCFFFF
SA221	1	1	0	1	1	1	0	1	128/64	1BA0000–1BBFFFF	0DD0000–0DDFFFF
SA222	1	1	0	1	1	1	1	0	128/64	1BC0000–1BDFFFF	0DE0000–0DEFFFF
SA223	1	1	0	1	1	1	1	1	128/64	1BE0000–1BFFFFFF	0DF0000–0DFFFFFF
SA224	1	1	1	0	0	0	0	0	128/64	1C00000–1C1FFFF	0E00000–0E0FFFF
SA225	1	1	1	0	0	0	0	1	128/64	1C20000–1C3FFFF	0E10000–0E1FFFF
SA226	1	1	1	0	0	0	1	0	128/64	1C40000–1C5FFFF	0E20000–0E2FFFF
SA227	1	1	1	0	0	0	1	1	128/64	1C60000–1C7FFFF	0E30000–0E3FFFF
SA228	1	1	1	0	0	1	0	0	128/64	1C80000–1C9FFFF	0E40000–0E4FFFF
SA229	1	1	1	0	0	1	0	1	128/64	1CA0000–1CBFFFF	0E50000–0E5FFFF
SA230	1	1	1	0	0	1	1	0	128/64	1CC0000–1CDFFFF	0E60000–0E6FFFF
SA231	1	1	1	0	0	1	1	1	128/64	1CE0000–1CFFFFFF	0E70000–0E7FFFF
SA232	1	1	1	0	1	0	0	0	128/64	1D00000–1D1FFFF	0E80000–0E8FFFF



**Table 2. Sector Address Table–S29GL256N (Continued)**

Sector	A23–A16								Sector Size (Kbytes/ Kwords)	8-bit Address Range (in hexadecimal)	16-bit Address Range (in hexadecimal)
SA233	1	1	1	0	1	0	0	1	128/64	1D20000–1D3FFFF	0E90000–0E9FFFF
SA234	1	1	1	0	1	0	1	0	128/64	1D40000–1D5FFFF	0EA0000–0EAFFFF
SA235	1	1	1	0	1	0	1	1	128/64	1D60000–1D7FFFF	0EB0000–0EBFFFF
SA236	1	1	1	0	1	1	0	0	128/64	1D80000–1D9FFFF	0EC0000–0ECFFFF
SA237	1	1	1	0	1	1	0	1	128/64	1DA0000–1DBFFFF	0ED0000–0EDFFFF
SA238	1	1	1	0	1	1	1	0	128/64	1DC0000–1DDFFFF	0EE0000–0EEFFFF
SA239	1	1	1	0	1	1	1	1	128/64	1DE0000–1DFFFFF	0EF0000–0EFFFFF
SA240	1	1	1	1	0	0	0	0	128/64	1E00000–1E1FFFF	0F00000–0F0FFFF
SA241	1	1	1	1	0	0	0	1	128/64	1E20000–1E3FFFF	0F10000–0F1FFFF
SA242	1	1	1	1	0	0	1	0	128/64	1E40000–1E5FFFF	0F20000–0F2FFFF
SA243	1	1	1	1	0	0	1	1	128/64	1E60000–137FFFF	0F30000–0F3FFFF
SA244	1	1	1	1	0	1	0	0	128/64	1E80000–1E9FFFF	0F40000–0F4FFFF
SA245	1	1	1	1	0	1	0	1	128/64	1EA0000–1EBFFFF	0F50000–0F5FFFF
SA246	1	1	1	1	0	1	1	0	128/64	1EC0000–1EDFFFF	0F60000–0F6FFFF
SA247	1	1	1	1	0	1	1	1	128/64	1EE0000–1EFFFFF	0F70000–0F7FFFF
SA248	1	1	1	1	1	0	0	0	128/64	1F00000–1F1FFFF	0F80000–0F8FFFF
SA249	1	1	1	1	1	0	0	1	128/64	1F20000–1F3FFFF	0F90000–0F9FFFF
SA250	1	1	1	1	1	0	1	0	128/64	1F40000–1F5FFFF	0FA0000–0FAFFFF
SA251	1	1	1	1	1	0	1	1	128/64	1F60000–1F7FFFF	0FB0000–0FBFFFF
SA252	1	1	1	1	1	1	0	0	128/64	1F80000–1F9FFFF	0FC0000–0FCFFFF
SA253	1	1	1	1	1	1	0	1	128/64	1FA0000–1FBFFFF	0FD0000–0FDFFFF
SA254	1	1	1	1	1	1	1	0	128/64	1FC0000–1FDFFFF	0FE0000–0FEFFFF
SA255	1	1	1	1	1	1	1	1	128/64	1FE0000–1FFFFFF	0FF0000–0FFFFFF

**Table 3. Sector Address Table–S29GLI28N**

Sector	A22–A16						Sector Size (Kbytes/ Kwords)	8-bit Address Range (in hexadecimal)	16-bit Address Range (in hexadecimal)
SA0	0	0	0	0	0	0	128/64	0000000–001FFFF	0000000–000FFFF
SA1	0	0	0	0	0	1	128/64	0020000–003FFFF	0010000–001FFFF
SA2	0	0	0	0	1	0	128/64	0040000–005FFFF	0020000–002FFFF
SA3	0	0	0	0	1	1	128/64	0060000–007FFFF	0030000–003FFFF
SA4	0	0	0	1	0	0	128/64	0080000–009FFFF	0040000–004FFFF
SA5	0	0	0	1	0	1	128/64	00A0000–00BFFFF	0050000–005FFFF
SA6	0	0	0	1	1	0	128/64	00C0000–00DFFFF	0060000–006FFFF

**Table 3. Sector Address Table–S29GLI28N (Continued)**

Sector	A22–A16						Sector Size (Kbytes/ Kwords)	8-Bit Address Range (in hexadecimal)	16-bit Address Range (in hexadecimal)
SA7	0	0	0	1	1	1	128/64	00E0000–00FFFFFF	0070000–007FFFF
SA8	0	0	1	0	0	0	128/64	0100000–011FFFF	0080000–008FFFF
SA9	0	0	1	0	0	1	128/64	0120000–013FFFF	0090000–009FFFF
SA10	0	0	1	0	1	0	128/64	0140000–015FFFF	00A0000–00AFFFF
SA11	0	0	1	0	1	1	128/64	0160000–017FFFF	00B0000–00BFFFF
SA12	0	0	1	1	0	0	128/64	0180000–019FFFF	00C0000–00CFFFF
SA13	0	0	1	1	0	1	128/64	01A0000–01BFFFF	00D0000–00DFFFF
SA14	0	0	1	1	1	0	128/64	01C0000–01DFFFF	00E0000–00EFFFF
SA15	0	0	1	1	1	1	128/64	01E0000–01FFFFFF	00F0000–00FFFFFF
SA16	0	1	0	0	0	0	128/64	0200000–021FFFF	0100000–010FFFF
SA17	0	1	0	0	0	1	128/64	0220000–023FFFF	0110000–011FFFF
SA18	0	1	0	0	1	0	128/64	0240000–025FFFF	0120000–012FFFF
SA19	0	1	0	0	1	1	128/64	0260000–027FFFF	0130000–013FFFF
SA20	0	1	0	1	0	0	128/64	0280000–029FFFF	0140000–014FFFF
SA21	0	1	0	1	0	1	128/64	02A0000–02BFFFF	0150000–015FFFF
SA22	0	1	0	1	1	0	128/64	02C0000–02DFFFF	0160000–016FFFF
SA23	0	1	0	1	1	1	128/64	02E0000–02FFFFFF	0170000–017FFFF
SA24	0	1	1	0	0	0	128/64	0300000–031FFFF	0180000–018FFFF
SA25	0	1	1	0	0	1	128/64	0320000–033FFFF	0190000–019FFFF
SA26	0	1	1	0	1	0	128/64	0340000–035FFFF	01A0000–01AFFFF
SA27	0	1	1	0	1	1	128/64	0360000–037FFFF	01B0000–01BFFFF
SA28	0	1	1	1	0	0	128/64	0380000–039FFFF	01C0000–01CFFFF
SA29	0	1	1	1	0	1	128/64	03A0000–03BFFFF	01D0000–01DFFFF
SA30	0	1	1	1	1	0	128/64	03C0000–03DFFFF	01E0000–01EFFFF
SA31	0	1	1	1	1	1	128/64	03E0000–03FFFFFF	01F0000–01FFFFFF
SA32	1	0	0	0	0	0	128/64	0400000–041FFFF	0200000–020FFFF
SA33	1	0	0	0	0	1	128/64	0420000–043FFFF	0210000–021FFFF
SA34	1	0	0	0	1	0	128/64	0440000–045FFFF	0220000–022FFFF
SA35	1	0	0	0	1	1	128/64	0460000–047FFFF	0230000–023FFFF
SA36	1	0	0	1	0	0	128/64	0480000–049FFFF	0240000–024FFFF
SA37	1	0	0	1	0	1	128/64	04A0000–04BFFFF	0250000–025FFFF
SA38	1	0	0	1	1	0	128/64	04C0000–04DFFFF	0260000–026FFFF
SA39	1	0	0	1	1	1	128/64	04E0000–04FFFFFF	0270000–027FFFF
SA40	1	0	1	0	0	0	128/64	0500000–051FFFF	0280000–028FFFF
SA41	1	0	1	0	0	1	128/64	0520000–053FFFF	0290000–029FFFF

**Table 3. Sector Address Table–S29GLI28N (Continued)**

Sector	A22–A16						Sector Size (Kbytes/ Kwords)	8-Bit Address Range (in hexadecimal)	16-bit Address Range (in hexadecimal)
SA42	1	0	1	0	1	0	128/64	0540000–055FFFF	02A0000–02AFFFF
SA43	1	0	1	0	1	1	128/64	0560000–057FFFF	02B0000–02BFFFF
SA44	1	0	1	1	0	0	128/64	0580000–059FFFF	02C0000–02CFFFF
SA45	1	0	1	1	0	1	128/64	05A0000–05BFFFF	02D0000–02DFFFF
SA46	1	0	1	1	1	0	128/64	05C0000–05DFFFF	02E0000–02EFFFF
SA47	1	0	1	1	1	1	128/64	05E0000–05FFFFFF	02F0000–02FFFFFF
SA48	1	1	0	0	0	0	128/64	0600000–061FFFF	0300000–030FFFF
SA49	1	1	0	0	0	1	128/64	0620000–063FFFF	0310000–031FFFF
SA50	1	1	0	0	1	0	128/64	0640000–065FFFF	0320000–032FFFF
SA51	1	1	0	0	1	1	128/64	0660000–067FFFF	0330000–033FFFF
SA52	1	1	0	1	0	0	128/64	0680000–069FFFF	0340000–034FFFF
SA53	1	1	0	1	0	1	128/64	06A0000–06BFFFF	0350000–035FFFF
SA54	1	1	0	1	1	0	128/64	06C0000–06DFFFF	0360000–036FFFF
SA55	1	1	0	1	1	1	128/64	06E0000–06FFFFFF	0370000–037FFFF
SA56	1	1	1	0	0	0	128/64	0700000–071FFFF	0380000–038FFFF
SA57	1	1	1	0	0	1	128/64	0720000–073FFFF	0390000–039FFFF
SA58	1	1	1	0	1	0	128/64	0740000–075FFFF	03A0000–03AFFFF
SA59	1	1	1	0	1	1	128/64	0760000–077FFFF	03B0000–03BFFFF
SA60	1	1	1	1	0	0	128/64	0780000–079FFFF	03C0000–03CFFFF
SA61	1	1	1	1	0	1	128/64	07A0000–07BFFFF	03D0000–03DFFFF
SA62	1	1	1	1	1	0	128/64	07C0000–07DFFFF	03E0000–03EFFFF
SA63	1	1	1	1	1	1	128/64	07E0000–07FFFFFF	03F0000–03FFFFFF
SA64	0	0	0	0	0	0	128/64	0800000–081FFFF	0400000–040FFFF
SA65	0	0	0	0	0	1	128/64	0820000–083FFFF	0410000–041FFFF
SA66	0	0	0	0	1	0	128/64	0840000–085FFFF	0420000–042FFFF
SA67	0	0	0	0	1	1	128/64	0860000–087FFFF	0430000–043FFFF
SA68	0	0	0	1	0	0	128/64	0880000–089FFFF	0440000–044FFFF
SA69	0	0	0	1	0	1	128/64	08A0000–08BFFFF	0450000–045FFFF
SA70	0	0	0	1	1	0	128/64	08C0000–08DFFFF	0460000–046FFFF
SA71	0	0	0	1	1	1	128/64	08E0000–08FFFFFF	0470000–047FFFF
SA72	0	0	1	0	0	0	128/64	0900000–091FFFF	0480000–048FFFF
SA73	0	0	1	0	0	1	128/64	0920000–093FFFF	0490000–049FFFF
SA74	0	0	1	0	1	0	128/64	0940000–095FFFF	04A0000–04AFFFF
SA75	0	0	1	0	1	1	128/64	0960000–097FFFF	04B0000–04BFFFF
SA76	0	0	1	1	0	0	128/64	0980000–099FFFF	04C0000–04CFFFF

**Table 3. Sector Address Table–S29GLI28N (Continued)**

Sector	A22–A16						Sector Size (Kbytes/ Kwords)	8-Bit Address Range (in hexadecimal)	16-bit Address Range (in hexadecimal)
SA77	0	0	1	1	0	1	128/64	09A0000–09BFFFF	04D0000–04DFFFF
SA78	0	0	1	1	1	0	128/64	09C0000–09DFFFF	04E0000–04EFFFF
SA79	0	0	1	1	1	1	128/64	09E0000–09FFFFFF	04F0000–04FFFFFF
SA80	0	1	0	0	0	0	128/64	0A00000–0A1FFFF	0500000–050FFFF
SA81	0	1	0	0	0	1	128/64	0A20000–0A3FFFF	0510000–051FFFF
SA82	0	1	0	0	1	0	128/64	0A40000–0A5FFFF	0520000–052FFFF
SA83	0	1	0	0	1	1	128/64	0A60000–0A7FFFF	0530000–053FFFF
SA84	0	1	0	1	0	0	128/64	0A80000–0A9FFFF	0540000–054FFFF
SA85	0	1	0	1	0	1	128/64	0AA0000–0ABFFFF	0550000–055FFFF
SA86	0	1	0	1	1	0	128/64	0AC0000–0ADFFFF	0560000–056FFFF
SA87	0	1	0	1	1	1	128/64	0AE0000–0AFFFFF	0570000–057FFFF
SA88	0	1	1	0	0	0	128/64	0B00000–0B1FFFF	0580000–058FFFF
SA89	0	1	1	0	0	1	128/64	0B20000–0B3FFFF	0590000–059FFFF
SA90	0	1	1	0	1	0	128/64	0B40000–0B5FFFF	05A0000–05AFFFF
SA91	0	1	1	0	1	1	128/64	0B60000–0B7FFFF	05B0000–05BFFFF
SA92	0	1	1	1	0	0	128/64	0B80000–0B9FFFF	05C0000–05CFFFF
SA93	0	1	1	1	0	1	128/64	0BA0000–0BBFFFF	05D0000–05DFFFF
SA94	0	1	1	1	1	0	128/64	0BC0000–0BDFFFF	05E0000–05EFFFF
SA95	0	1	1	1	1	1	128/64	0BE0000–0BFFFFFF	05F0000–05FFFFFF
SA96	1	0	0	0	0	0	128/64	0C00000–0C1FFFF	0600000–060FFFF
SA97	1	0	0	0	0	1	128/64	0C20000–0C3FFFF	0610000–061FFFF
SA98	1	0	0	0	1	0	128/64	0C40000–0C5FFFF	0620000–062FFFF
SA99	1	0	0	0	1	1	128/64	0C60000–0C7FFFF	0630000–063FFFF
SA100	1	0	0	1	0	0	128/64	0C80000–0C9FFFF	0640000–064FFFF
SA101	1	0	0	1	0	1	128/64	0CA0000–0CBFFFF	0650000–065FFFF
SA102	1	0	0	1	1	0	128/64	0CC0000–0CDFFFF	0660000–066FFFF
SA103	1	0	0	1	1	1	128/64	0CE0000–0CFFFFF	0670000–067FFFF
SA104	1	0	1	0	0	0	128/64	0D00000–0D1FFFF	0680000–068FFFF
SA105	1	0	1	0	0	1	128/64	0D20000–0D3FFFF	0690000–069FFFF
SA106	1	0	1	0	1	0	128/64	0D40000–0D5FFFF	06A0000–06AFFFF
SA107	1	0	1	0	1	1	128/64	0D60000–0D7FFFF	06B0000–06BFFFF
SA108	1	0	1	1	0	0	128/64	0D80000–0D9FFFF	06C0000–06CFFFF
SA109	1	0	1	1	0	1	128/64	0DA0000–0DBFFFF	06D0000–06DFFFF
SA110	1	0	1	1	1	0	128/64	0DC0000–0DDFFFF	06E0000–06EFFFF
SA111	1	0	1	1	1	1	128/64	0DE0000–0DEFFFF	06F0000–06FFFFFF

Table 3. Sector Address Table–S29GLI28N (Continued)

Sector	A22–A16						Sector Size (Kbytes/ Kwords)	8-Bit Address Range (in hexadecimal)	16-bit Address Range (in hexadecimal)
SA112	1	1	0	0	0	0	128/64	0E0000–0E1FFFF	0700000–070FFFF
SA113	1	1	0	0	0	1	128/64	0E20000–0E3FFFF	0710000–071FFFF
SA114	1	1	0	0	1	0	128/64	0E40000–0E5FFFF	0720000–072FFFF
SA115	1	1	0	0	1	1	128/64	0E60000–0E7FFFF	0730000–073FFFF
SA116	1	1	0	1	0	0	128/64	0E80000–0E9FFFF	0740000–074FFFF
SA117	1	1	0	1	0	1	128/64	0EA0000–0EBFFFF	0750000–075FFFF
SA118	1	1	0	1	1	0	128/64	0EC0000–0EDFFFF	0760000–076FFFF
SA119	1	1	0	1	1	1	128/64	0EE0000–0EFFFFFF	0770000–077FFFF
SA120	1	1	1	0	0	0	128/64	0F00000–0F1FFFF	0780000–078FFFF
SA121	1	1	1	0	0	1	128/64	0F20000–0F3FFFF	0790000–079FFFF
SA122	1	1	1	0	1	0	128/64	0F40000–0F5FFFF	07A0000–07AFFFF
SA123	1	1	1	0	1	1	128/64	0F60000–0F7FFFF	07B0000–07BFFFF
SA124	1	1	1	1	0	0	128/64	0F80000–0F9FFFF	07C0000–07CFFFF
SA125	1	1	1	1	0	1	128/64	0FA0000–0FBFFFF	07D0000–07DFFFF
SA126	1	1	1	1	1	0	128/64	0FC0000–0FDFFFF	07E0000–07EFFFF
SA127	1	1	1	1	1	1	128/64	0FE0000–0FFFFFF	07F0000–07FFFFFF

### Sector Protection

The device features several levels of sector protection, which can disable both the program and erase operations in certain sectors or sector groups:

#### **Persistent Sector Protection**

A command sector protection method that replaces the old 12 V controlled protection method.

#### **Password Sector Protection**

A highly sophisticated protection method that requires a password before changes to certain sectors or sector groups are permitted

#### **WP# Hardware Protection**

A write protect pin that can prevent program or erase operations in the outermost sectors.

The WP# Hardware Protection feature is always available, independent of the software managed protection method chosen.

### Selecting a Sector Protection Mode

All parts default to operate in the Persistent Sector Protection mode. The customer must then choose if the Persistent or Password Protection method is most desirable. There are two one-time programmable non-volatile bits that define which sector protection method will be used. If the customer decides to continue using the Persistent Sector Protection method, they must set the **Persistent Sector Protection Mode Locking Bit**. This will permanently set the part to op-

erate only using Persistent Sector Protection. If the customer decides to use the password method, they must set the **Password Mode Locking Bit**. This will permanently set the part to operate only using password sector protection.

It is important to remember that setting either the **Persistent Sector Protection Mode Locking Bit** or the **Password Mode Locking Bit** permanently selects the protection mode. It is not possible to switch between the two methods once a locking bit has been set. **It is important that one mode is explicitly selected when the device is first programmed, rather than relying on the default mode alone.** This is so that it is not possible for a system program or virus to later set the Password Mode Locking Bit, which would cause an unexpected shift from the default Persistent Sector Protection Mode into the Password Protection Mode.

The device is shipped with all sectors unprotected. The factory offers the option of programming and protecting sectors at the factory prior to shipping the device through the ExpressFlash™ Service. Contact your sales representative for details.

It is possible to determine whether a sector is protected or unprotected. See "Autoselect Command Sequence" section on page 50 for details.

## Advanced Sector Protection

Advanced Sector Protection features several levels of sector protection, which can disable both the program and erase operations in certain sectors.

**Persistent Sector Protection** is a method that replaces the old 12V controlled protection method.

**Password Sector Protection** is a highly sophisticated protection method that requires a password before changes to certain sectors are permitted.

Advanced Sector Protection is available when  $ACC = V_{HH}$ .

## Lock Register

The Lock Register consists of 3 bits (DQ2, DQ1, and DQ0). These DQ2, DQ1, DQ0 bits of the Lock Register are programmable by the user. Users are not allowed to program both DQ2 and DQ1 bits of the Lock Register to the 00 state. If the user tries to program DQ2 and DQ1 bits of the Lock Register to the 00 state, the device will abort the Lock Register back to the default 11 state. The programming time of the Lock Register is same as the typical word programming time without utilizing the Write Buffer of the device. During a Lock Register programming sequence execution, the DQ6 Toggle Bit I will toggle until the programming of the Lock Register has completed to indicate programming status. All Lock Register bits are readable to allow users to verify Lock Register statuses. Initial access delay is required to read the Lock Register.

The Customer Secured Silicon Sector Protection Bit is DQ0, Persistent Protection Mode Lock Bit is DQ1, and Password Protection Mode Lock Bit is DQ2 are accessible by all users. Each of these bits are non-volatile. DQ15-DQ3 are reserved and must be 1's when the user tries to program the DQ2, DQ1, and DQ0 bits of the Lock Register. The user is not required to program DQ2, DQ1 and DQ0 bits of the Lock Register at the same time. This allows users to lock the Secured Silicon Sector and then set the device either permanently into Password Protection Mode or Persistent Protection Mode and then lock the Secured Silicon Sector at separate instances and time frames.

- Secured Silicon Sector Protection allows the user to lock the Secured Silicon Sector area

- Persistent Protection Mode Lock Bit allows the user to set the device permanently to operate in the Persistent Protection Mode
- Password Protection Mode Lock Bit allows the user to set the device permanently to operate in the Password Protection Mode

**Table 4. Lock Register**

DQ15-3	DQ2	DQ1	DQ0
Don't Care	Password Protection Mode Lock Bit	Persistent Protection Mode Lock Bit	Secured Silicon Sector Protection Bit

### Persistent Sector Protection

The Persistent Sector Protection method replaces the old 12 V controlled protection method while at the same time enhancing flexibility by providing three different sector protection states:

- **Dynamically Locked**-The sector is protected and can be changed by a simple command
- **Persistently Locked**-A sector is protected and cannot be changed
- **Unlocked**-The sector is unprotected and can be changed by a simple command

In order to achieve these states, three types of "bits" are going to be used:

#### Dynamic Protection Bit (DYB)

A volatile protection bit is assigned for each sector. After power-up or hardware reset, the contents of all DYB bits are in the "unprotected state" if the DYB Lock Bit of the "Lock Register" is not programmed. If the DYB Lock Bit of the "Lock Register" is programmed, all DYB bits will power-up or hardware reset to the "protected state". Each DYB is individually modifiable through the DYB Set Command and DYB Clear Command. When the parts are first shipped, all of the Persistent Protect Bits (PPB) are cleared into the unprotected state. The DYB bits and PPB Lock bit are defaulted to power up in the cleared state or unprotected state - meaning the all PPB bits are changeable.

The Protection State for each sector is determined by the logical OR of the PPB and the DYB related to that sector. For the sectors that have the PPB bits cleared, the DYB bits control whether or not the sector is protected or unprotected. By issuing the DYB Set and DYB Clear command sequences, the DYB bits will be protected or unprotected, thus placing each sector in the protected or unprotected state. These are the so-called Dynamic Locked or Unlocked states. They are called dynamic states because it is very easy to switch back and forth between the protected and un-protected conditions. This allows software to easily protect sectors against inadvertent changes yet does not prevent the easy removal of protection when changes are needed.

The DYB bits maybe set or cleared as often as needed. The PPB bits allow for a more static, and difficult to change, level of protection. The PPB bits retain their state across power cycles because they are Non-Volatile. Individual PPB bits are set with a program command but must all be cleared as a group through an erase command.

The PPB Lock Bit adds an additional level of protection. Once all PPB bits are programmed to the desired settings, the PPB Lock Bit may be set to the "freeze

state". Setting the PPB Lock Bit to the "freeze state" disables all program and erase commands to the Non-Volatile PPB bits. In effect, the PPB Lock Bit locks the PPB bits into their current state. The only way to clear the PPB Lock Bit to the "unfreeze state" is to go through a power cycle, or hardware reset. The Software Reset command will not clear the PPB Lock Bit to the "unfreeze state". System boot code can determine if any changes to the PPB bits are needed e.g. to allow new system code to be downloaded. If no changes are needed then the boot code can set the PPB Lock Bit to disable any further changes to the PPB bits during system operation.

The WP# write protect pin adds a final level of hardware protection. When this pin is low it is not possible to change the contents of the WP# protected sectors. These sectors generally hold system boot code. So, the WP# pin can prevent any changes to the boot code that could override the choices made while setting up sector protection during system initialization.

It is possible to have sectors that have been persistently locked, and sectors that are left in the dynamic state. The sectors in the dynamic state are all unprotected. If there is a need to protect some of them, a simple DYB Set command sequence is all that is necessary. The DYB Set and DYB Clear commands for the dynamic sectors switch the DYB bits to signify protected and unprotected, respectively. If there is a need to change the status of the persistently locked sectors, a few more steps are required. First, the PPB Lock Bit must be disabled to the "unfreeze state" by either putting the device through a power-cycle, or hardware reset. The PPB bits can then be changed to reflect the desired settings. Setting the PPB Lock Bit once again to the "freeze state" will lock the PPB bits, and the device operates normally again.

Note: to achieve the best protection, it's recommended to execute the PPB Lock Bit Set command early in the boot code, and protect the boot code by holding  $WP\# = V_{IL}$ .

### Persistent Protection Bit (PPB)

A single Persistent (non-volatile) Protection Bit is assigned to each sector. If a PPB is programmed to the protected state through the "PPB Program" command, that sector will be protected from program or erase operations will be read-only. If a PPB requires erasure, all of the sector PPB bits must first be erased in parallel through the "All PPB Erase" command. The "All PPB Erase" command will pre-programmed all PPB bits prior to PPB erasing. All PPB bits erase in parallel, unlike programming where individual PPB bits are programmable. The PPB bits have the same endurance as the flash memory.

Programming the PPB bit requires the typical word programming time without utilizing the Write Buffer. During a PPB bit programming and A11 PPB bit erasing sequence execution, the DQ6 Toggle Bit I will toggle until the programming of the PPB bit or erasing of all PPB bits has completed to indicate programming and erasing status. Erasing all of the PPB bits at once requires typical sector erase time. During the erasing of all PPB bits, the DQ3 Sector Erase Timer bit will output a 1 to indicate the erasure of all PPB bits are in progress. When the erasure of all PPB bits has completed, the DQ3 Sector Erase Timer bit will output a 0 to indicate that all PPB bits have been erased. Reading the PPB Status bit requires the initial access time of the device.



### Persistent Protection Bit Lock (PPB Lock Bit)

A global volatile bit. When set to the “freeze state”, the PPB bits cannot be changed. When cleared to the “unfreeze state”, the PPB bits are changeable. There is only one PPB Lock Bit per device. The PPB Lock Bit is cleared to the “unfreeze state” after power-up or hardware reset. There is no command sequence to unlock or “unfreeze” the PPB Lock Bit.

Configuring the PPB Lock Bit to the freeze state requires approximately 100ns. Reading the PPB Lock Status bit requires the initial access time of the device.

**Table 5. Sector Protection Schemes**

Protection States			Sector State
DYB Bit	PPB Bit	PPB Lock Bit	
Unprotect	Unprotect	Unfreeze	Unprotected – PPB and DYB are changeable
Unprotect	Unprotect	Freeze	Unprotected – PPB not changeable, DYB is changeable
Unprotect	Protect	Unfreeze	Protected – PPB and DYB are changeable
Unprotect	Protect	Freeze	Protected – PPB not changeable, DYB is changeable
Protect	Unprotect	Unfreeze	Protected – PPB and DYB are changeable
Protect	Unprotect	Freeze	Protected – PPB not changeable, DYB is changeable
Protect	Protect	Unfreeze	Protected – PPB and DYB are changeable
Protect	Protect	Freeze	Protected – PPB not changeable, DYB is changeable

Table 7 contains all possible combinations of the DYB bit, PPB bit, and PPB Lock Bit relating to the status of the sector. In summary, if the PPB bit is set, and the PPB Lock Bit is set, the sector is protected and the protection cannot be removed until the next power cycle or hardware reset clears the PPB Lock Bit to “unfreeze state”. If the PPB bit is cleared, the sector can be dynamically locked or unlocked. The DYB bit then controls whether or not the sector is protected or unprotected. If the user attempts to program or erase a protected sector, the device ignores the command and returns to read mode. A program command to a protected sector enables status polling for approximately 1 μs before the device returns to read mode without having modified the contents of the protected sector. An erase command to a protected sector enables status polling for approximately 50 μs after which the device returns to read mode without having erased the protected sector. The programming of the DYB bit, PPB bit, and PPB Lock Bit for a given sector can be verified by writing a DYB Status Read, PPB Status Read, and PPB Lock Status Read commands to the device.

The Autoselect Sector Protection Verification outputs the OR function of the DYB bit and PPB bit per sector basis. When the OR function of the DYB bit and PPB bit is a 1, the sector is either protected by DYB or PPB or both. When the OR function of the DYB bit and PPB bit is a 0, the sector is unprotected through both the DYB and PPB.

### Persistent Protection Mode Lock Bit

Like the Password Protection Mode Lock Bit, a Persistent Protection Mode Lock Bit exists to guarantee that the device remain in software sector protection. Once programmed, the Persistent Protection Mode Lock Bit prevents programming of

the Password Protection Mode Lock Bit. This guarantees that a hacker could not place the device in Password Protection Mode. The Password Protection Mode Lock Bit resides in the "Lock Register".

## Password Sector Protection

The Password Sector Protection method allows an even higher level of security than the Persistent Sector Protection method. There are two main differences between the Persistent Sector Protection and the Password Sector Protection methods:

- When the device is first powered on, or comes out of a reset cycle, the PPB Lock Bit is set to the locked state, or the freeze state, rather than cleared to the unlocked state, or the unfreeze state.
- The only means to clear and unfreeze the PPB Lock Bit is by writing a unique 64-bit Password to the device.

The Password Sector Protection method is otherwise identical to the Persistent Sector Protection method.

A 64-bit password is the only additional tool utilized in this method.

The password is stored in a one-time programmable (OTP) region outside of the flash memory. Once the Password Protection Mode Lock Bit is set, the password is permanently set with no means to read, program, or erase it. The password is used to clear and unfreeze the PPB Lock Bit. The Password Unlock command must be written to the flash, along with a password. The flash device internally compares the given password with the pre-programmed password. If they match, the PPB Lock Bit is cleared to the "unfrozen state", and the PPB bits can be altered. If they do not match, the flash device does nothing. There is a built-in 2  $\mu$ s delay for each "password check" after the valid 64-bit password has been entered for the PPB Lock Bit to be cleared to the "unfrozen state". This delay is intended to thwart any efforts to run a program that tries all possible combinations in order to crack the password.

## Password and Password Protection Mode Lock Bit

In order to select the Password Sector Protection method, the customer must first program the password. The factory recommends that the password be somehow correlated to the unique Electronic Serial Number (ESN) of the particular flash device. Each ESN is different for every flash device; therefore each password should be different for every flash device. While programming in the password region, the customer may perform Password Read operations. Once the desired password is programmed in, the customer must then set the Password Protection Mode Lock Bit. This operation achieves two objectives:

1. It permanently sets the device to operate using the Password Protection Mode. It is not possible to reverse this function.
2. It also disables all further commands to the password region. All program, and read operations are ignored.

Both of these objectives are important, and if not carefully considered, may lead to unrecoverable errors. The user must be sure that the Password Sector Protection method is desired when programming the Password Protection Mode Lock Bit. More importantly, the user must be sure that the password is correct when the Password Protection Mode Lock Bit is programmed. Due to the fact that read operations are disabled, there is no means to read what the password is afterwards. If the password is lost after programming the Password Protection Mode

Lock Bit, there will be no way to clear and unfreeze the PPB Lock Bit. The Password Protection Mode Lock Bit, once programmed, prevents reading the 64-bit password on the DQ bus and further password programming. The Password Protection Mode Lock Bit is not erasable. Once Password Protection Mode Lock Bit is programmed, the Persistent Protection Mode Lock Bit is disabled from programming, guaranteeing that no changes to the protection scheme are allowed.

## 64-bit Password

The 64-bit Password is located in its own memory space and is accessible through the use of the Password Program and Password Read commands. The password function works in conjunction with the Password Protection Mode Lock Bit, which when programmed, prevents the Password Read command from reading the contents of the password on the pins of the device.

## Persistent Protection Bit Lock (PPB Lock Bit)

A global volatile bit. The PPB Lock Bit is a volatile bit that reflects the state of the Password Protection Mode Lock Bit after power-up reset. If the Password Protection Mode Lock Bit is also programmed after programming the Password, the Password Unlock command must be issued to clear and unfreeze the PPB Lock Bit after a hardware reset (RESET# asserted) or a power-up reset. Successful execution of the Password Unlock command clears and unfreezes the PPB Lock Bit, allowing for sector PPB bits to be modified. Without issuing the Password Unlock command, while asserting RESET#, taking the device through a power-on reset, or issuing the PPB Lock Bit Set command sets the PPB Lock Bit to a the "freeze state".

If the Password Protection Mode Lock Bit is not programmed, the device defaults to Persistent Protection Mode. In the Persistent Protection Mode, the PPB Lock Bit is cleared to the "unfreeze state" after power-up or hardware reset. The PPB Lock Bit is set to the "freeze state" by issuing the PPB Lock Bit Set command. Once set to the "freeze state" the only means for clearing the PPB Lock Bit to the "unfreeze state" is by issuing a hardware or power-up reset. The Password Unlock command is ignored in Persistent Protection Mode.

Reading the PPB Lock Bit requires a 200ns access time.

## Secured Silicon Sector Flash Memory Region

The Secured Silicon Sector feature provides a Flash memory region that enables permanent part identification through an Electronic Serial Number (ESN). The Secured Silicon Sector is 256 bytes in length, and uses a Secured Silicon Sector Indicator Bit (DQ7) to indicate whether or not the Secured Silicon Sector is locked when shipped from the factory. This bit is permanently set at the factory and cannot be changed, which prevents cloning of a factory locked part. This ensures the security of the ESN once the product is shipped to the field.

The factory offers the device with the Secured Silicon Sector either customer lockable (standard shipping option) or factory locked (contact an AMD sales representative for ordering information). The customer-lockable version is shipped with the Secured Silicon Sector unprotected, allowing customers to program the sector after receiving the device. The customer-lockable version also has the Secured Silicon Sector Indicator Bit permanently set to a "0." The factory-locked version is always protected when shipped from the factory, and has the Secured Silicon Sector Indicator Bit permanently set to a "1." Thus, the Secured Silicon Sector Indicator Bit prevents customer-lockable devices from being used to re-

place devices that are factory locked. *Note that the ACC function and unlock bypass modes are not available when the Secured Silicon Sector is enabled.*

The Secured Silicon sector address space in this device is allocated as follows:

Secured Silicon Sector Address Range	Customer Lockable	ESN Factory Locked	ExpressFlash Factory Locked
000000h–000007h	Determined by customer	ESN	ESN or determined by customer
000008h–00007Fh		Unavailable	Determined by customer

The system accesses the Secured Silicon Sector through a command sequence (see “Write Protect (WP#)”). After the system has written the Enter Secured Silicon Sector command sequence, it may read the Secured Silicon Sector by using the addresses normally occupied by the first sector (SA0). This mode of operation continues until the system issues the Exit Secured Silicon Sector command sequence, or until power is removed from the device. On power-up, or following a hardware reset, the device reverts to sending commands to sector SA0.

**Customer Lockable: Secured Silicon Sector NOT Programmed or Protected At the Factory**

Unless otherwise specified, the device is shipped such that the customer may program and protect the 256-byte Secured Silicon sector.

The system may program the Secured Silicon Sector using the write-buffer, accelerated and/or unlock bypass methods, in addition to the standard programming command sequence. See Command Definitions.

Programming and protecting the Secured Silicon Sector must be used with caution since, once protected, there is no procedure available for unprotecting the Secured Silicon Sector area and none of the bits in the Secured Silicon Sector memory space can be modified in any way.

The Secured Silicon Sector area can be protected using one of the following procedures:

- Write the three-cycle Enter Secured Silicon Sector Region command sequence, and then follow the in-system sector protect algorithm as shown in [Figure 2](#), except that *RESET#* may be at either  $V_{IH}$  or  $V_{ID}$ . This allows in-system protection of the Secured Silicon Sector without raising any device pin to a high voltage. Note that this method is only applicable to the Secured Silicon Sector.
- To verify the protect/unprotect status of the Secured Silicon Sector, follow the algorithm shown in [Figure 1](#).

Once the Secured Silicon Sector is programmed, locked and verified, the system must write the Exit Secured Silicon Sector Region command sequence to return to reading and writing within the remainder of the array.

**Factory Locked: Secured Silicon Sector Programmed and Protected At the Factory**

In devices with an ESN, the Secured Silicon Sector is protected when the device is shipped from the factory. The Secured Silicon Sector cannot be modified in any way. An ESN Factory Locked device has an 16-byte random ESN at addresses 000000h–000007h. Please contact your sales representative for details on ordering ESN Factory Locked devices.

Customers may opt to have their code programmed by the factory through the ExpressFlash service (Express Flash Factory Locked). The devices are then

shipped from the factory with the Secured Silicon Sector permanently locked. Contact your sales representative for details on using the ExpressFlash service.

## Write Protect (WP#)

The Write Protect function provides a hardware method of protecting the first or last sector group without using  $V_{ID}$ . Write Protect is one of two functions provided by the WP#/ACC input.

If the system asserts  $V_{IL}$  on the WP#/ACC pin, the device disables program and erase functions in the first or last sector group independently of whether those sector groups were protected or unprotected using the method described in "Advanced Sector Protection" section on page 38. Note that if WP#/ACC is at  $V_{IL}$  when the device is in the standby mode, the maximum input load current is increased. See the table in "DC Characteristics" section on page 78.

**If the system asserts  $V_{IH}$  on the WP#/ACC pin, the device reverts to whether the first or last sector was previously set to be protected or unprotected using the method described in "Sector Group Protection and Unprotection". Note that WP# has an internal pullup; when unconnected, WP# is at  $V_{IH}$ .**

## Hardware Data Protection

The command sequence requirement of unlock cycles for programming or erasing provides data protection against inadvertent writes (refer to Tables 16 and 17 for command definitions). In addition, the following hardware data protection measures prevent accidental erasure or programming, which might otherwise be caused by spurious system level signals during  $V_{CC}$  power-up and power-down transitions, or from system noise.

### Low $V_{CC}$ Write Inhibit

When  $V_{CC}$  is less than  $V_{LKO}$ , the device does not accept any write cycles. This protects data during  $V_{CC}$  power-up and power-down. The command register and all internal program/erase circuits are disabled, and the device resets to the read mode. Subsequent writes are ignored until  $V_{CC}$  is greater than  $V_{LKO}$ . The system must provide the proper signals to the control pins to prevent unintentional writes when  $V_{CC}$  is greater than  $V_{LKO}$ .

### Write Pulse "Glitch" Protection

Noise pulses of less than 5 ns (typical) on OE#, CE# or WE# do not initiate a write cycle.

### Logical Inhibit

Write cycles are inhibited by holding any one of OE# =  $V_{IL}$ , CE# =  $V_{IH}$  or WE# =  $V_{IH}$ . To initiate a write cycle, CE# and WE# must be a logical zero while OE# is a logical one.

### Power-Up Write Inhibit

If WE# = CE# =  $V_{IL}$  and OE# =  $V_{IH}$  during power up, the device does not accept commands on the rising edge of WE#. The internal state machine is automatically reset to the read mode on power-up.

## Common Flash Memory Interface (CFI)

The Common Flash Interface (CFI) specification outlines device and host system software interrogation handshake, which allows specific vendor-specified software algorithms to be used for entire families of devices. Software support can then be device-independent, JEDEC ID-independent, and forward- and backward-compatible for the specified flash device families. Flash vendors can standardize their existing interfaces for long-term compatibility.

This device enters the CFI Query mode when the system writes the CFI Query command, 98h, to address 55h, any time the device is ready to read array data. The system can read CFI information at the addresses given in Tables 8-11. To terminate reading CFI data, the system must write the reset command.

The system can also write the CFI query command when the device is in the autoselect mode. The device enters the CFI query mode, and the system can read CFI data at the addresses given in Tables 8-11. The system must write the reset command to return the device to reading array data.

For further information, please refer to the CFI Specification and CFI Publication 100, available via the World Wide Web at <http://www.amd.com/flash/cfi>. Alternatively, contact your sales representative for copies of these documents.

Table 6. CFI Query Identification String

Addresses (x16)	Data	Description
10h 11h 12h	0051h 0052h 0059h	Query Unique ASCII string "QRY"
13h 14h	0002h 0000h	Primary OEM Command Set
15h 16h	0040h 0000h	Address for Primary Extended Table
17h 18h	0000h 0000h	Alternate OEM Command Set (00h = none exists)
19h 1Ah	0000h 0000h	Address for Alternate OEM Extended Table (00h = none exists)

Table 7. System Interface String

Addresses (x16)	Data	Description
1Bh	0027h	V <sub>CC</sub> Min. (write/erase) D7–D4: volt, D3–D0: 100 millivolt
1Ch	0036h	V <sub>CC</sub> Max. (write/erase) D7–D4: volt, D3–D0: 100 millivolt
1Dh	0000h	V <sub>PP</sub> Min. voltage (00h = no V <sub>PP</sub> pin present)
1Eh	0000h	V <sub>PP</sub> Max. voltage (00h = no V <sub>PP</sub> pin present)
1Fh	0007h	Typical timeout per single byte/word write 2 <sup>N</sup> μs
20h	0007h	Typical timeout for Min. size buffer write 2 <sup>N</sup> μs (00h = not supported)
21h	000Ah	Typical timeout per individual block erase 2 <sup>N</sup> ms
22h	0000h	Typical timeout for full chip erase 2 <sup>N</sup> ms (00h = not supported)
23h	0001h	Max. timeout for byte/word write 2 <sup>N</sup> times typical
24h	0005h	Max. timeout for buffer write 2 <sup>N</sup> times typical
25h	0004h	Max. timeout per individual block erase 2 <sup>N</sup> times typical
26h	0000h	Max. timeout for full chip erase 2 <sup>N</sup> times typical (00h = not supported)

**Table 8. Device Geometry Definition**

Addresses (x16)	Data	Description
27h	001Ah 0019h 0018h	Device Size = 2 <sup>n</sup> byte 1A = 512 Mb, 19 = 256 Mb, 18 = 128 Mb
28h 29h	0002h 0000h	Flash Device Interface description (refer to CFI publication 100)
2Ah 2Bh	0005h 0000h	Max. number of byte in multi-byte write = 2 <sup>n</sup> (00h = not supported)
2Ch	0001h	Number of Erase Block Regions within device (01h = uniform device, 02h = boot device)
2Dh 2Eh 2Fh 30h	00xxh 000xh 0000h 000xh	Erase Block Region 1 Information (refer to the CFI specification or CFI publication 100) 00FFh, 001h, 0000h, 0002h = 512 Mb 00FFh, 0000h, 0000h, 0002h = 256 Mb 007Fh, 0000h, 0000h, 0002h = 128 Mb
31h 32h 33h 34h	0000h 0000h 0000h 0000h	Erase Block Region 2 Information (refer to CFI publication 100)
35h 36h 37h 38h	0000h 0000h 0000h 0000h	Erase Block Region 3 Information (refer to CFI publication 100)
39h 3Ah 3Bh 3Ch	0000h 0000h 0000h 0000h	Erase Block Region 4 Information (refer to CFI publication 100)



Table 9. Primary Vendor-Specific Extended Query

Addresses (x16)	Data	Description
40h 41h 42h	0050h 0052h 0049h	Query-unique ASCII string "PRI"
43h	0031h	Major version number, ASCII
44h	0033h	Minor version number, ASCII
45h	0010h	Address Sensitive Unlock (Bits 1-0) 0 = Required, 1 = Not Required Process Technology (Bits 7-2) 0100b = 110 nm MirrorBit
46h	0002h	Erase Suspend 0 = Not Supported, 1 = To Read Only, 2 = To Read & Write
47h	0001h	Sector Protect 0 = Not Supported, X = Number of sectors in per group
48h	0000h	Sector Temporary Unprotect 00 = Not Supported, 01 = Supported
49h	0008h	Sector Protect/Unprotect scheme 0008h = Advanced Sector Protection
4Ah	0000h	Simultaneous Operation 00 = Not Supported, X = Number of Sectors in Bank
4Bh	0000h	Burst Mode Type 00 = Not Supported, 01 = Supported
4Ch	0002h	Page Mode Type 00 = Not Supported, 01 = 4 Word Page, 02 = 8 Word Page
4Dh	00B5h	ACC (Acceleration) Supply Minimum 00h = Not Supported, D7-D4: Volt, D3-D0: 100 mV
4Eh	00C5h	ACC (Acceleration) Supply Maximum 00h = Not Supported, D7-D4: Volt, D3-D0: 100 mV
4Fh	0004h/ 0005h	Top/Bottom Boot Sector Flag 00h = Uniform Device without WP# protect, 02h = Bottom Boot Device, 03h = Top Boot Device, 04h = Uniform sectors bottom WP# protect, 05h = Uniform sectors top WP# protect
50h	0001h	Program Suspend 00h = Not Supported, 01h = Supported

## Command Definitions

Writing specific address and data commands or sequences into the command register initiates device operations. Table 10 and Table 11 define the valid register command sequences. *Writing incorrect address and data values or writing them in the improper sequence may place the device in an unknown state.* A reset command is then required to return the device to reading array data.

All addresses are latched on the falling edge of WE# or CE#, whichever happens later. All data is latched on the rising edge of WE# or CE#, whichever happens first. Refer to the AC Characteristics section for timing diagrams.

## Reading Array Data

The device is automatically set to reading array data after device power-up. No commands are required to retrieve data. The device is ready to read array data after completing an Embedded Program or Embedded Erase algorithm.

After the device accepts an Erase Suspend command, the device enters the erase-suspend-read mode, after which the system can read data from any non-erase-suspended sector. After completing a programming operation in the Erase Suspend mode, the system may once again read array data with the same exception. See the Erase Suspend/Eraser Resume Commands section for more information.

The system *must* issue the reset command to return the device to the read (or erase-suspend-read) mode if DQ5 goes high during an active program or erase operation, or if the device is in the autoselect mode. See the next section, Reset Command, for more information.

See also Requirements for Reading Array Data in the Device Bus Operations section for more information. The Read-Only Operations—"AC Characteristics" section on page 80 provides the read parameters, and Figure 11 shows the timing diagram.

## Reset Command

Writing the reset command resets the device to the read or erase-suspend-read mode. Address bits are don't cares for this command.

The reset command may be written between the sequence cycles in an erase command sequence before erasing begins. This resets the device to the read mode. Once erasure begins, however, the device ignores reset commands until the operation is complete.

The reset command may be written between the sequence cycles in a program command sequence before programming begins. This resets the device to the read mode. If the program command sequence is written while the device is in the Erase Suspend mode, writing the reset command returns the device to the erase-suspend-read mode. Once programming begins, however, the device ignores reset commands until the operation is complete.

The reset command may be written between the sequence cycles in an autoselect command sequence. Once in the autoselect mode, the reset command must be written to return to the read mode. If the device entered the autoselect mode while in the Erase Suspend mode, writing the reset command returns the device to the erase-suspend-read mode.

If DQ5 goes high during a program or erase operation, writing the reset command returns the device to the read mode (or erase-suspend-read mode if the device was in Erase Suspend).

Note that if DQ1 goes high during a Write Buffer Programming operation, the system must write the Write-to-Buffer-Abort Reset command sequence to reset the device for the next operation.

## Autoselect Command Sequence

The autoselect command sequence allows the host system to access the manufacturer and device codes, and determine whether or not a sector is protected. Table 10 and Table 11 show the address and data requirements. This method requires  $V_{ID}$  on address pin A9. The autoselect command sequence may be written

to an address that is either in the read or erase-suspend-read mode. The autoselect command may not be written while the device is actively programming or erasing.

The autoselect command sequence is initiated by first writing two unlock cycles. This is followed by a third write cycle that contains the autoselect command. The device then enters the autoselect mode. The system may read at any address any number of times without initiating another autoselect command sequence:

- A read cycle at address XX00h returns the manufacturer code.
- Three read cycles at addresses 01h, 0Eh, and 0Fh return the device code.
- A read cycle to an address containing a sector address (SA), and the address 02h on A7–A0 in word mode returns 01h if the sector is protected, or 00h if it is unprotected.

The system must write the reset command to return to the read mode (or erase-suspend-read mode if the device was previously in Erase Suspend).

### Enter Secured Silicon Sector/Exit Secured Silicon Sector Command Sequence

The Secured Silicon Sector region provides a secured data area containing an 8-word/16-byte random Electronic Serial Number (ESN). The system can access the Secured Silicon Sector region by issuing the three-cycle Enter Secured Silicon Sector command sequence. The device continues to access the Secured Silicon Sector region until the system issues the four-cycle Exit Secured Silicon Sector command sequence. The Exit Secured Silicon Sector command sequence returns the device to normal operation. Table 10 and Table 11 show the address and data requirements for both command sequences. See also "Secured Silicon Sector Flash Memory Region" for further information. *Note that the ACC function and unlock bypass modes are not available when the Secured Silicon Sector is enabled.*

### Word Program Command Sequence

Programming is a four-bus-cycle operation. The program command sequence is initiated by writing two unlock write cycles, followed by the program set-up command. The program address and data are written next, which in turn initiate the Embedded Program algorithm. The system is *not* required to provide further controls or timings. The device automatically provides internally generated program pulses and verifies the programmed cell margin. Table 10 and Table 11 show the address and data requirements for the word program command sequence.

When the Embedded Program algorithm is complete, the device then returns to the read mode and addresses are no longer latched. The system can determine the status of the program operation by using DQ7 or DQ6. Refer to the Write Operation Status section for information on these status bits.

Any commands written to the device during the Embedded Program Algorithm are ignored. **Note that the Secured Silicon Sector, autoselect, and CFI functions are unavailable when a program operation is in progress.** Note that a **hardware reset** immediately terminates the program operation. The program command sequence should be reinitiated once the device has returned to the read mode, to ensure data integrity.

Programming is allowed in any sequence and across sector boundaries. Programming to the same word address multiple times without intervening erases is limited. For such application requirements, please contact your local Spansion representative. **Any word cannot be programmed from "0" back to a "1."** Attempting to do so may cause the device to set DQ5 = 1, or cause the DQ7 and

DQ6 status bits to indicate the operation was successful. However, a succeeding read will show that the data is still "0." Only erase operations can convert a "0" to a "1."

### Unlock Bypass Command Sequence

The unlock bypass feature allows the system to program words to the device faster than using the standard program command sequence. The unlock bypass command sequence is initiated by first writing two unlock cycles. This is followed by a third write cycle containing the unlock bypass command, 20h. The device then enters the unlock bypass mode. A two-cycle unlock bypass program command sequence is all that is required to program in this mode. The first cycle in this sequence contains the unlock bypass program command, A0h; the second cycle contains the program address and data. Additional data is programmed in the same manner. This mode dispenses with the initial two unlock cycles required in the standard program command sequence, resulting in faster total programming time. Table 10 and Table 11 show the requirements for the command sequence.

During the unlock bypass mode, only the Unlock Bypass Program and Unlock Bypass Reset commands are valid. To exit the unlock bypass mode, the system must issue the two-cycle unlock bypass reset command sequence. (See Table 10 and Table 11).

### Write Buffer Programming

Write Buffer Programming allows the system write to a maximum of 16 words/32 bytes in one programming operation. This results in faster effective programming time than the standard programming algorithms. The Write Buffer Programming command sequence is initiated by first writing two unlock cycles. This is followed by a third write cycle containing the Write Buffer Load command written at the Sector Address in which programming will occur. The fourth cycle writes the sector address and the number of word locations, minus one, to be programmed. For example, if the system will program 6 unique address locations, then 05h should be written to the device. This tells the device how many write buffer addresses will be loaded with data and therefore when to expect the Program Buffer to Flash command. The number of locations to program cannot exceed the size of the write buffer or the operation will abort.

The fifth cycle writes the first address location and data to be programmed. The write-buffer-page is selected by address bits  $A_{MAX}-A_4$ . All subsequent address/data pairs must fall within the selected-write-buffer-page. The system then writes the remaining address/data pairs into the write buffer. Write buffer locations may be loaded in any order.

The write-buffer-page address must be the same for all address/data pairs loaded into the write buffer. (This means Write Buffer Programming cannot be performed across multiple write-buffer pages. This also means that Write Buffer Programming cannot be performed across multiple sectors. If the system attempts to load programming data outside of the selected write-buffer page, the operation will abort.)

Note that if a Write Buffer address location is loaded multiple times, the address/data pair counter will be decremented for every data load operation. The host system must therefore account for loading a write-buffer location more than once. The counter decrements for each data load operation, not for each unique write-buffer-address location. Note also that if an address location is loaded more

than once into the buffer, the final data loaded for that address will be programmed.

Once the specified number of write buffer locations have been loaded, the system must then write the Program Buffer to Flash command at the sector address. Any other address and data combination aborts the Write Buffer Programming operation. The device then begins programming. Data polling should be used while monitoring the last address location loaded into the write buffer. DQ7, DQ6, DQ5, and DQ1 should be monitored to determine the device status during Write Buffer Programming.

The write-buffer programming operation can be suspended using the standard program suspend/resume commands. Upon successful completion of the Write Buffer Programming operation, the device is ready to execute the next command.

The Write Buffer Programming Sequence can be aborted in the following ways:

- Load a value that is greater than the page buffer size during the Number of Locations to Program step.
- Write to an address in a sector different than the one specified during the Write-Buffer-Load command.
- Write an Address/Data pair to a different write-buffer-page than the one selected by the Starting Address during the write buffer data loading stage of the operation.
- Write data other than the Confirm Command after the specified number of data load cycles.

The abort condition is indicated by DQ1 = 1, DQ7 = DATA# (for the last address location loaded), DQ6 = toggle, and DQ5=0. A Write-to-Buffer-Abort Reset command sequence must be written to reset the device for the next operation. Note that the full 3-cycle Write-to-Buffer-Abort Reset command sequence is required when using Write-Buffer-Programming features in Unlock Bypass mode.

Write buffer programming is allowed in any sequence. Note that the Secured Silicon sector, autoselect, and CFI functions are unavailable when a program operation is in progress. This flash device is capable of handling multiple write buffer programming operations on the same write buffer address range without intervening erases. For applications requiring an excessive number of such repeated write buffer programming operations, please contact your local Spansion representative. **Any bit in a write buffer address range cannot be programmed from "0" back to a "1."** Attempting to do so may cause the device to set DQ5 = 1, or cause the DQ7 and DQ6 status bits to indicate the operation was successful. However, a succeeding read will show that the data is still "0." Only erase operations can convert a "0" to a "1."

### Accelerated Program

The device offers accelerated program operations through the WP#/ACC pin. When the system asserts  $V_{HH}$  on the WP#/ACC pin, the device automatically enters the Unlock Bypass mode. The system may then write the two-cycle Unlock Bypass program command sequence. The device uses the higher voltage on the WP#/ACC pin to accelerate the operation. *Note that the WP#/ACC pin must not be at  $V_{HH}$  for operations other than accelerated programming, or device damage may result. WP# has an internal pullup; when unconnected, WP# is at  $V_{IH}$ .*

Figure 3 illustrates the algorithm for the program operation. Refer to the Erase and Program Operations—"AC Characteristics" section on page 80 section for parameters, and Figure 14 for timing diagrams.

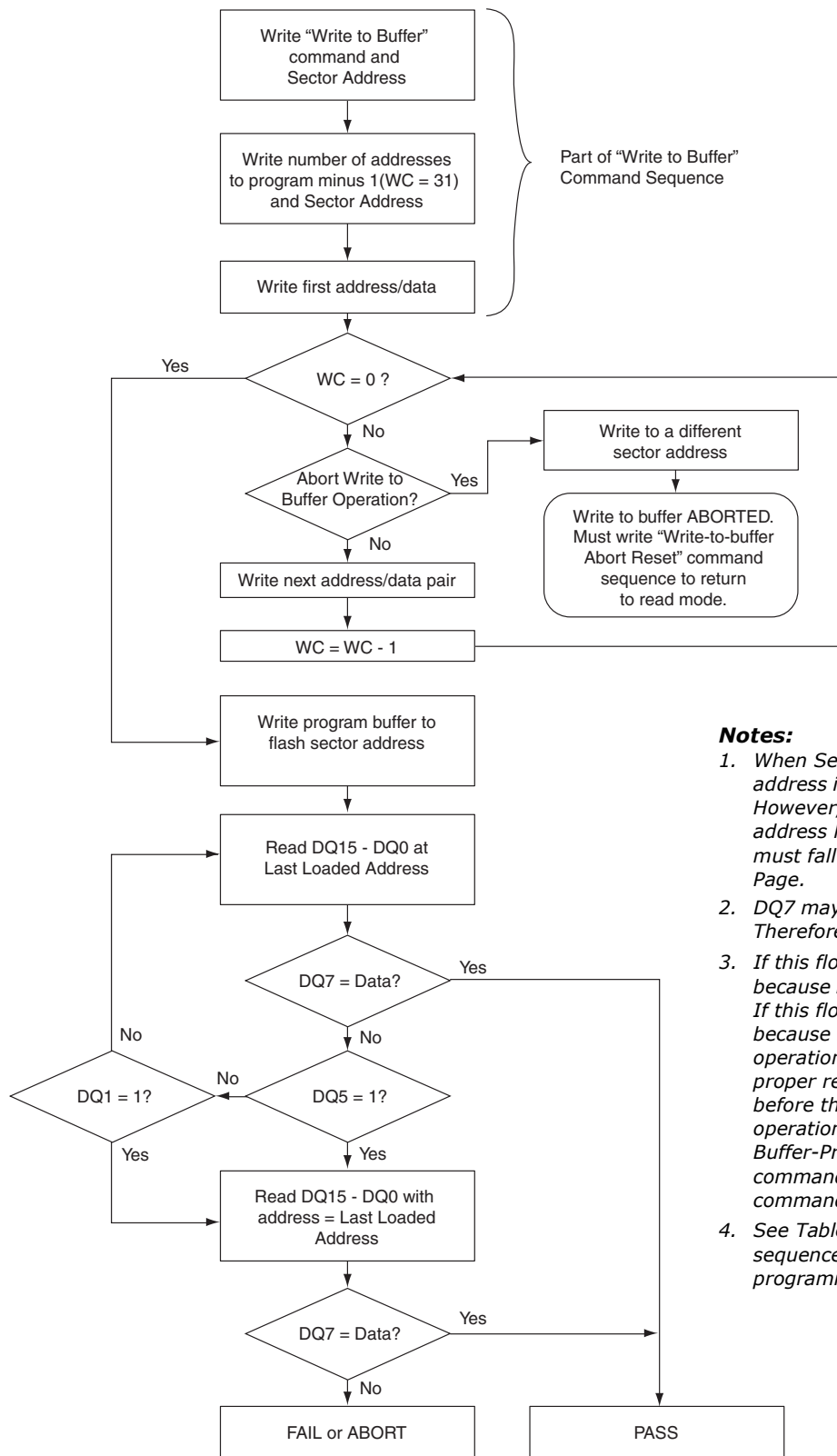

**Notes:**

1. When Sector Address is specified, any address in the selected sector is acceptable. However, when loading Write-Buffer address locations with data, all addresses must fall within the selected Write-Buffer Page.
2. DQ7 may change simultaneously with DQ5. Therefore, DQ7 should be verified.
3. If this flowchart location was reached because DQ5= "1", then the device FAILED. If this flowchart location was reached because DQ1= "1", then the Write to Buffer operation was ABORTED. In either case, the proper reset command must be written before the device can begin another operation. If DQ1=1, write the Write-Buffer-Programming-Abort-Reset command. If DQ5=1, write the Reset command.
4. See Tables 16 and 17 for command sequences required for write buffer programming.

Figure I. Write Buffer Programming Operation

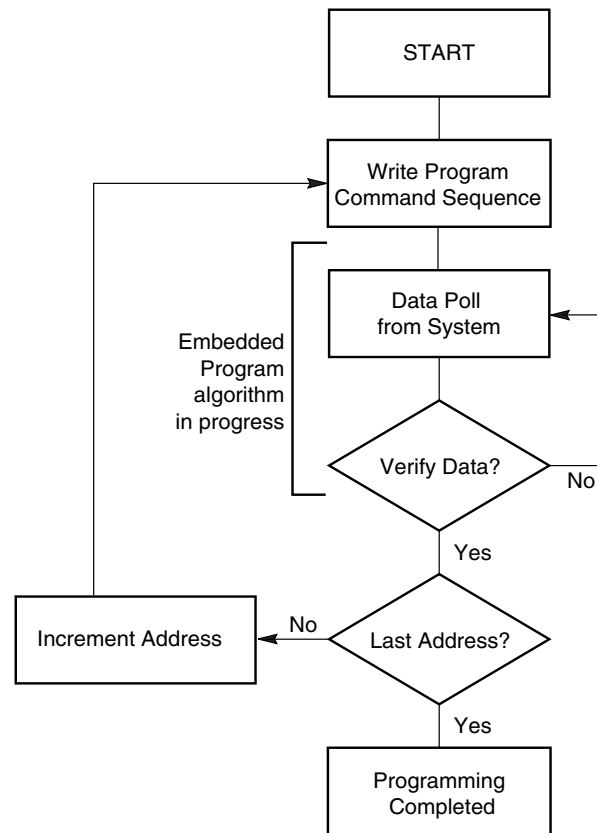

**Note:** See Table 10 and Table 11 for program command sequence.

**Figure 2. Program Operation**

### Program Suspend/Program Resume Command Sequence

The Program Suspend command allows the system to interrupt a programming operation or a Write to Buffer programming operation so that data can be read from any non-suspended sector. When the Program Suspend command is written during a programming process, the device halts the program operation within 15  $\mu\text{s}$  maximum (5 $\mu\text{s}$  typical) and updates the status bits. Addresses are not required when writing the Program Suspend command.

After the programming operation has been suspended, the system can read array data from any non-suspended sector. The Program Suspend command may also be issued during a programming operation while an erase is suspended. In this case, data may be read from any addresses not in Erase Suspend or Program Suspend. If a read is needed from the Secured Silicon Sector area (One-time Program area), then user must use the proper command sequences to enter and exit this region.

The system may also write the autoselect command sequence when the device is in the Program Suspend mode. The system can read as many autoselect codes as required. When the device exits the autoselect mode, the device reverts to the Program Suspend mode, and is ready for another valid operation. See Autoselect Command Sequence for more information.

After the Program Resume command is written, the device reverts to programming. The system can determine the status of the program operation using the DQ7 or DQ6 status bits, just as in the standard program operation. See Write Operation Status for more information.

The system must write the Program Resume command (address bits are don't care) to exit the Program Suspend mode and continue the programming operation. Further writes of the Resume command are ignored. Another Program Suspend command can be written after the device has resume programming.

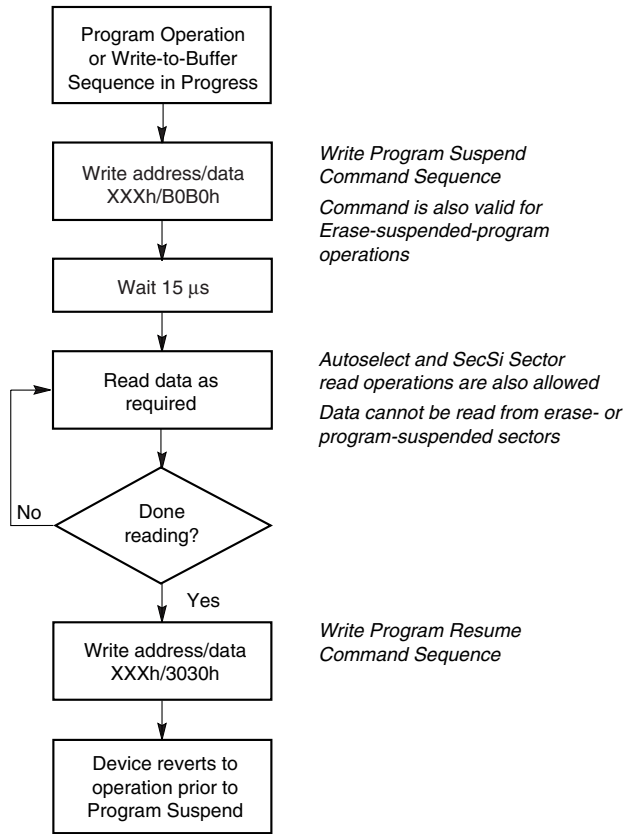

**Figure 3. Program Suspend/Program Resume**

### Chip Erase Command Sequence

Chip erase is a six bus cycle operation. The chip erase command sequence is initiated by writing two unlock cycles, followed by a set-up command. Two additional unlock write cycles are then followed by the chip erase command, which in turn invokes the Embedded Erase algorithm. The device does *not* require the system to preprogram prior to erase. The Embedded Erase algorithm automatically preprograms and verifies the entire memory for an all zero data pattern prior to electrical erase. The system is not required to provide any controls or timings during these operations. Table 10 and Table 11 show the address and data requirements for the chip erase command sequence.

When the Embedded Erase algorithm is complete, the device returns to the read mode and addresses are no longer latched. The system can determine the status of the erase operation by using DQ7, DQ6, or DQ2. Refer to the Write Operation Status section for information on these status bits.



Any commands written during the chip erase operation are ignored, including erase suspend commands. However, note that a **hardware reset** immediately terminates the erase operation. If that occurs, the chip erase command sequence should be reinitiated once the device has returned to reading array data, to ensure data integrity.

Figure 4 illustrates the algorithm for the erase operation. **Note that the Secured Silicon Sector, autoselect, and CFI functions are unavailable when an erase operation is in progress.** Refer to the Erase and Program Operations table in the AC Characteristics section for parameters, and Figure 16 section for timing diagrams.

## Sector Erase Command Sequence

Sector erase is a six bus cycle operation. The sector erase command sequence is initiated by writing two unlock cycles, followed by a set-up command. Two additional unlock cycles are written, and are then followed by the address of the sector to be erased, and the sector erase command. Table 10 and Table 11 shows the address and data requirements for the sector erase command sequence.

The device does *not* require the system to preprogram prior to erase. The Embedded Erase algorithm automatically programs and verifies the entire memory for an all zero data pattern prior to electrical erase. The system is not required to provide any controls or timings during these operations.

After the command sequence is written, a sector erase time-out of 50  $\mu$ s occurs. During the time-out period, additional sector addresses and sector erase commands may be written. Loading the sector erase buffer may be done in any sequence, and the number of sectors may be from one sector to all sectors. The time between these additional cycles must be less than 50  $\mu$ s, otherwise erasure may begin. Any sector erase address and command following the exceeded time-out may or may not be accepted. It is recommended that processor interrupts be disabled during this time to ensure all commands are accepted. The interrupts can be re-enabled after the last Sector Erase command is written. **Any command other than Sector Erase or Erase Suspend during the time-out period resets the device to the read mode. Note that the Secured Silicon Sector, autoselect, and CFI functions are unavailable when an erase operation is in progress.** The system must rewrite the command sequence and any additional addresses and commands.

The system can monitor DQ3 to determine if the sector erase timer has timed out (See the section on DQ3: Sector Erase Timer.). The time-out begins from the rising edge of the final WE# pulse in the command sequence.

When the Embedded Erase algorithm is complete, the device returns to reading array data and addresses are no longer latched. The system can determine the status of the erase operation by reading DQ7, DQ6, or DQ2 in the erasing sector. Refer to the Write Operation Status section for information on these status bits.

Once the sector erase operation has begun, only the Erase Suspend command is valid. All other commands are ignored. However, note that a **hardware reset** immediately terminates the erase operation. If that occurs, the sector erase command sequence should be reinitiated once the device has returned to reading array data, to ensure data integrity.

Figure 4 illustrates the algorithm for the erase operation. Refer to the Erase and Program Operations table in the AC Characteristics section for parameters, and Figure 16 section for timing diagrams.

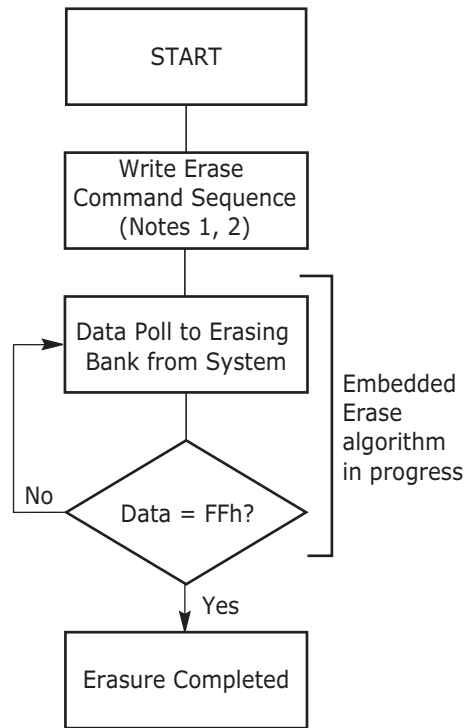

**Notes:**

1. See Table 10 and Table 11 for program command sequence.
2. See the section on DQ3 for information on the sector erase timer.

**Figure 4. Erase Operation**

### Erase Suspend/Erasure Resume Commands

The Erase Suspend command, B0h, allows the system to interrupt a sector erase operation and then read data from, or program data to, any sector not selected for erasure. This command is valid only during the sector erase operation, including the 50  $\mu$ s time-out period during the sector erase command sequence. The Erase Suspend command is ignored if written during the chip erase operation or Embedded Program algorithm.

When the Erase Suspend command is written during the sector erase operation, the device requires a typical of 5  $\mu$ s (maximum of 20  $\mu$ s) to suspend the erase operation. However, when the Erase Suspend command is written during the sector erase time-out, the device immediately terminates the time-out period and suspends the erase operation.

After the erase operation has been suspended, the device enters the erase-suspend-read mode. The system can read data from or program data to any sector not selected for erasure. (The device "erase suspends" all sectors selected for erasure.) Reading at any address within erase-suspended sectors produces status information on DQ7–DQ0. The system can use DQ7, or DQ6 and DQ2 together, to determine if a sector is actively erasing or is erase-suspended. Refer to the Write Operation Status section for information on these status bits.

After an erase-suspended program operation is complete, the device returns to the erase-suspend-read mode. The system can determine the status of the pro-

gram operation using the DQ7 or DQ6 status bits, just as in the standard word program operation. Refer to the Write Operation Status section for more information.

In the erase-suspend-read mode, the system can also issue the autoselect command sequence. Refer to the "Autoselect Command Sequence" section on page 50 sections for details.

To resume the sector erase operation, the system must write the Erase Resume command. The address of the erase-suspended sector is required when writing this command. Further writes of the Resume command are ignored. Another Erase Suspend command can be written after the chip has resumed erasing.

## Lock Register Command Set Definitions

The Lock Register Command Set permits the user to one-time program the Secured Silicon Sector Protection Bit, Persistent Protection Mode Lock Bit, and Password Protection Mode Lock Bit. The Lock Register bits are all readable after an initial access delay.

The **Lock Register Command Set Entry** command sequence must be issued prior to any of the following commands listed, to enable proper command execution.

Note that issuing the **Lock Register Command Set Entry** command **disables reads and writes for the flash memory**.

- Lock Register Program Command
- Lock Register Read Command

The **Lock Register Command Set Exit** command must be issued after the execution of the commands to reset the device to read mode. Otherwise the device will hang. If this happens, the flash device must be reset. Please refer to RESET# for more information. It is important to note that the device will be in either Persistent Protection mode or Password Protection mode depending on the mode selected prior to the device hang.

For either the Secured Silicon Sector to be locked, or the device to be permanently set to the Persistent Protection Mode or the Password Protection Mode, the associated Lock Register bits must be programmed. **Note that the Persistent Protection Mode Lock Bit and Password Protection Mode Lock Bit can never be programmed together at the same time. If so, the Lock Register Program operation will abort.**

**The Lock Register Command Set Exit command must be initiated to re-enable reads and writes to the main memory.**

## Password Protection Command Set Definitions

The Password Protection Command Set permits the user to program the 64-bit password, verify the programming of the 64-bit password, and then later unlock the device by issuing the valid 64-bit password.

The **Password Protection Command Set Entry** command sequence must be issued prior to any of the following commands listed, to enable proper command execution.

Note that issuing the **Password Protection Command Set Entry** command **disables reads and writes for the main memory**.

- Password Program Command

The Password Program command permits programming the password that is used as part of the hardware protection scheme. The actual password is 64-bits long. There is no special addressing order required for programming the password. **The password is programmed in 8-bit or 16-bit portions. Each portion requires a Password Program Command.**

Once the Password is written and verified, the Password Protection Mode Lock Bit in the "Lock Register" must be programmed in order to prevent verification. The Password Program command is only capable of programming "0"s. Programming a "1" after a cell is programmed as a "0" results in a time-out by the Embedded Program Algorithm™ with the cell remaining as a "0". The password is all F's when shipped from the factory. All 64-bit password combinations are valid as a password.

#### ■ Password Read Command

The Password Read command is used to verify the Password. The Password is verifiable only when the Password Protection Mode Lock Bit in the "Lock Register" is not programmed. If the Password Protection Mode Lock Bit in the "Lock Register" is programmed and the user attempts to read the Password, the device will always drive all F's onto the DQ data bus.

The lower two address bits (A1-A0) for word mode and (A1-A-1) for by byte mode are valid during the Password Read, Password Program, and Password Unlock commands. **Writing a "1" to any other address bits (A<sub>MAX</sub>-A2) will abort the Password Read, Password Program, and Password Unlock commands and return the device to reading memory array. The address bits (A1-A0) for word mode and (A1-A-1) for byte mode must be entered into the device sequentially for Password Read and Password Unlock commands.**

#### ■ Password Unlock Command

The Password Unlock command is used to clear the PPB Lock Bit to the "unfreeze state" so that the PPB bits can be modified. The exact password must be entered in order for the unlocking function to occur. **This 64-bit Password Unlock command sequence will take at least 2 μs to process each time to prevent a hacker from running through the all 64-bit combinations in an attempt to correctly match a password. If another password unlock is issued before the 64-bit password check execution window is completed, the command will be ignored.**

The Password Unlock function is accomplished by writing Password Unlock command and data to the device to perform the clearing of the PPB Lock Bit to the "unfreeze state". The password is 64 bits long. A1 and A0 are used for matching in word mode and A1, A0, A-1 in byte mode. Writing the Password Unlock command does not need to be address order specific. An example sequence is starting with the lower address A1-A0= 00, followed by A1-A0= 01, A1-A0= 10, and A1-A0= 11 if device is configured to operate in word mode.

**Approximately 2 μs is required for unlocking the device after the valid 64-bit password is given to the device. It is the responsibility of the microprocessor to keep track of the entering the portions of the 64-bit password with the Password Unlock command, the order, and when to read the PPB Lock bit to confirm successful password unlock.** In order to re-lock the device into the Password Protection Mode, the PPB Lock Bit Set command can be re-issued.

The **Password Protection Command Set Exit** command must be issued after the execution of the commands listed previously to reset the device to read mode. Otherwise the device will hang.

Note that issuing the **Password Protection Command Set Exit** command **re-enables reads and writes for the main memory**.

## Non-Volatile Sector Protection Command Set Definitions

The Non-Volatile Sector Protection Command Set permits the user to program the Persistent Protection Bits (PPB bits), erase all of the Persistent Protection Bits (PPB bits), and read the logic state of the Persistent Protection Bits (PPB bits).

The **Non-Volatile Sector Protection Command Set Entry** command sequence must be issued prior to any of the commands listed following to enable proper command execution.

Note that issuing the **Non-Volatile Sector Protection Command Set Entry** command **disables reads and writes for the main memory**.

### ■ PPB Program Command

The PPB Program command is used to program, or set, a given PPB bit. Each PPB bit is individually programmed (but is bulk erased with the other PPB bits). The specific sector address (A24-A16 for S29GL512N, A23-A16 for S29GL256N, A22-A16 for S29GL128N) is written at the same time as the program command. If the PPB Lock Bit is set to the "freeze state", the PPB Program command will not execute and the command will time-out without programming the PPB bit.

### ■ All PPB Erase Command

The All PPB Erase command is used to erase all PPB bits in bulk. There is no means for individually erasing a specific PPB bit. Unlike the PPB program, no specific sector address is required. However, when the All PPB Erase command is issued, all Sector PPB bits are erased in parallel. If the PPB Lock Bit is set to "freeze state", the ALL PPB Erase command will not execute and the command will time-out without erasing the PPB bits.

The device will preprogram all PPB bits prior to erasing when issuing the All PPB Erase command. Also note that the total number of PPB program/erase cycles has the same endurance as the flash memory array.

### ■ PPB Status Read Command

The programming state of the PPB for a given sector can be verified by writing a PPB Status Read Command to the device. This requires an initial access time latency.

The **Non-Volatile Sector Protection Command Set Exit** command must be issued after the execution of the commands listed previously to reset the device to read mode.

Note that issuing the **Non-Volatile Sector Protection Command Set Exit** command **re-enables reads and writes for the main memory**.

## Global Volatile Sector Protection Freeze Command Set

The Global Volatile Sector Protection Freeze Command Set permits the user to set the PPB Lock Bit and reading the logic state of the PPB Lock Bit.

The **Global Volatile Sector Protection Freeze Command Set Entry** command sequence must be issued prior to any of the commands listed following to enable proper command execution.

**Reads and writes from the main memory are allowed.**

■ PPB Lock Bit Set Command

The PPB Lock Bit Set command is used to set the PPB Lock Bit to the “freeze state” if it is cleared either at reset or if the Password Unlock command was successfully executed. There is no PPB Lock Bit Clear command. Once the PPB Lock Bit is set to the “freeze state”, it cannot be cleared unless the device is taken through a power-on clear (for Persistent Protection Mode) or the Password Unlock command is executed (for Password Protection Mode). If the Password Protection Mode Lock Bit is programmed, the PPB Lock Bit status is reflected as set to the “freeze state”, even after a power-on reset cycle.

■ PPB Lock Bit Status Read Command

The programming state of the PPB Lock Bit can be verified by executing a PPB Lock Bit Status Read command to the device.

The **Global Volatile Sector Protection Freeze Command Set Exit** command must be issued after the execution of the commands listed previously to reset the device to read mode.

**Volatile Sector Protection Command Set**

The Volatile Sector Protection Command Set permits the user to set the Dynamic Protection Bit (DYB) to the “protected state”, clear the Dynamic Protection Bit (DYB) to the “unprotected state”, and read the logic state of the Dynamic Protection Bit (DYB).

The **Volatile Sector Protection Command Set Entry** command sequence must be issued prior to any of the commands listed following to enable proper command execution.

Note that issuing the **Volatile Sector Protection Command Set Entry** command **disables reads for the bank selected with the command. Reads and Writes for other banks excluding that bank are allowed.**

■ DYB Set Command

■ DYB Clear Command

The DYB Set and DYB Clear commands are used to protect or unprotect a DYB for a given sector. The high order address bits are issued at the same time as the code 00h or 01h on DQ7-DQ0. All other DQ data bus pins are ignored during the data write cycle. The DYB bits are modifiable at any time, regardless of the state of the PPB bit or PPB Lock Bit. The DYB bits are cleared to the “unprotected state” at power-up or hardware reset.

—DYB Status Read Command

The programming state of the DYB bit for a given sector can be verified by writing a DYB Status Read command to the device. This requires an initial access delay.

The **Volatile Sector Protection Command Set Exit** command must be issued after the execution of the commands listed previously to reset the device to read mode.

Note that issuing the **Volatile Sector Protection Command Set Exit command re-enables reads and writes to the main memory.**

**Secured Silicon Sector Entry Command**

The Secured Silicon Sector Entry command allows the following commands to be executed

- Read from Secured Silicon Sector
- Program to Secured Silicon Sector

Once the Secured Silicon Sector Entry Command is issued, the Secured Silicon Sector Exit command has to be issued to exit Secured Silicon Sector Mode.

### **Secured Silicon Sector Exit Command**

The Secured Silicon Sector Exit command may be issued to exit the Secured Silicon Sector Mode.

## Command Definitions

**Table 10. S29GL512N, S29GL256N, S29GL128N Command Definitions, x16**

Command (Notes)		Cycles	Bus Cycles (Notes 2–5)											
			First		Second		Third		Fourth		Fifth		Sixth	
			Addr	Data	Addr	Data	Addr	Data	Addr	Data	Addr	Data	Addr	Data
Read (6)		1	RA	RD										
Reset (7)		1	XXX	F0										
Autoselect (Note 8)	Manufacturer ID	4	555	AA	2AA	55	555	90	X00	01				
	Device ID	4	555	AA	2AA	55	555	90	X01	227E	X0E	Note 17	X0F	Note 17
	Sector Protect Verify	4	555	AA	2AA	55	555	90	(SA) X02	XX00 XX01				
	Secure Device Verify (9)	4	555	AA	2AA	55	555	90	X03	Note 10				
CFI Query (11)		1	555	98										
Program		4	555	AA	2AA	55	555	A0	PA	PD				
Write to Buffer		3	555	AA	2AA	55	SA	25	SA	WC	PA	PD	WBL	PD
Program Buffer to Flash (confirm)		1	SA	29										
Write-to-Buffer-Abort Reset (16)		3	555	AA	2AA	55	555	F0						
Unlock Bypass		3	555	AA	2AA	55	555	20						
Unlock Bypass Program (12)		2	XXX	A0	PA	PD								
Unlock Bypass Sector Erase (12)		2	XXX	80	SA	30								
Unlock Bypass Chip Erase (12)		2	XXX	80	XXX	10								
Unlock Bypass Reset (13)		2	XXX	90	XXX	00								
Chip Erase		6	555	AA	2AA	55	555	80	555	AA	2AA	55	555	10
Sector Erase		6	555	AA	2AA	55	555	80	555	AA	2AA	55	SA	30
Erase Suspend/Program Suspend (14)		1	XXX	B0										
Erase Resume/Program Resume (15)		1	XXX	30										
<b>Sector Command Definitions</b>														
Secured Silicon Sector	Secured Silicon Sector Entry	3	555	AA	2AA	55	555	88						
	Secured Silicon Sector Exit (18)	4	555	AA	2AA	55	555	90	XX	00				
<b>Lock Register Command Set Definitions</b>														
Lock Register	Lock Register Command Set Entry	3	555	AA	2AA	55	555	40						
	Lock Register Bits Program (22)	2	XXX	A0	XXX	Data								
	Lock Register Bits Read (22)	1	00	Data										
	Lock Register Command Set Exit (18, 23)	2	XXX	90	XXX	00								
<b>Password Protection Command Set Definitions</b>														



Command (Notes)		Cycles	Bus Cycles (Notes 2-5)											
			First		Second		Third		Fourth		Fifth		Sixth	
			Addr	Data	Addr	Data	Addr	Data	Addr	Data	Addr	Data	Addr	Data
Password	Password Protection Command Set Entry	3	555	AA	2AA	55	555	60						
	Password Program (20)	2	XXX	A0	PWA <sub>x</sub>	PWD <sub>x</sub>								
	Password Read (19)	4	XXX	PWD <sub>0</sub>	01	PWD <sub>1</sub>	02	PWD <sub>2</sub>	03	PWD <sub>3</sub>				
	Password Unlock (19)	7	00	25	00	03	00	PWD <sub>0</sub>	01	PWD <sub>1</sub>	02	PWD <sub>2</sub>	03	PWD <sub>3</sub>
			00	29										
Password Protection Command Set Exit (18, 23)	2	XXX	90	XXX	00									
<b>Non-Volatile Sector Protection Command Set Definitions</b>														
PPB	Nonvolatile Sector Protection Command Set Entry	3	555	AA	2AA	55	555	C0						
	PPB Program (24, 25)	2	XXX	A0	SA	00								
	All PPB Erase	2	XXX	80	00	30								
	PPB Status Read (25)	1	SA	RD (0)										
	Non-Volatile Sector Protection Command Set Exit (18)	2	XXX	90	XXX	00								
<b>Global Non-Volatile Sector Protection Freeze Command Set Definitions</b>														
PPB Lock Bit	Global Non-Volatile Sector Protection Freeze Command Set Entry	3	555	AA	2AA	55	555	50						
	PPB Lock Bit Set (25)	2	XXX	A0	XXX	00								
	PPB Lock Status Read (25)	1	XXX	RD (0)										
	Global Non-Volatile Sector Protection Freeze Command Set Exit (18)	2	XXX	90	XXX	00								
<b>Volatile Sector Protection Command Set Definitions</b>														
DYB	Volatile Sector Protection Command Set Entry	3	555	AA	2AA	55	555	E0						
	DYB Set (24, 25)	2	XXX	A0	SA	00								
	DYB Clear (25)	2	XXX	A0	SA	01								
	DYB Status Read (25)	1	SA	RD (0)										
	Volatile Sector Protection Command Set Exit (18)	2	XXX	90	XXX	00								

**Legend:**

X = Don't care

RA = Address of the memory to be read.

RD = Data read from location RA during read operation.

PA = Address of the memory location to be programmed. Addresses latch on the falling edge of the WE# or CE# pulse, whichever happens later.

PD = Data to be programmed at location PA. Data latches on the rising edge of the WE# or CE# pulse, whichever happens first.

SA = Address of the sector to be verified (in autoselect mode) or erased. Address bits A<sub>max</sub>-A16 uniquely select any sector.

WBL = Write Buffer Location. The address must be within the same write buffer page as PA.

WC = Word Count is the number of write buffer locations to load minus 1.

PWD = Password

PWD<sub>x</sub> = Password word0, word1, word2, and word3.

DATA = Lock Register Contents: PD(0) = Secured Silicon Sector Protection Bit, PD(1) = Persistent Protection Mode Lock Bit, PD(2) = Password Protection Mode Lock Bit.

**Notes:**

1. See [Table 1](#) for description of bus operations.
2. All values are in hexadecimal.
3. Except for the read cycle, and the 4th, 5th, and 6th cycle of the autoselect command sequence, all bus cycles are write cycles.
4. Data bits DQ15-DQ8 are don't cares for unlock and command cycles.
5. Address bits A<sub>MAX</sub>:A16 are don't cares for unlock and command cycles, unless SA or PA required. (A<sub>MAX</sub> is the Highest Address pin.).
6. No unlock or command cycles required when reading array data.
7. The Reset command is required to return to reading array data when device is in the autoselect mode, or if DQ5 goes high (while the device is providing status data).
8. The fourth, fifth, and sixth cycle of the autoselect command sequence is a read cycle.
9. The data is 00h for an unprotected sector and 01h for a protected sector. See "Autoselect Command Sequence" for more information. This is same as PPB Status Read except that the protect and unprotect statuses are inverted here.
10. The data value for DQ7 is "1" for a serialized and protected OTP region and "0" for an unserialized and unprotected Secured Silicon Sector region. See "Secured Silicon Sector Flash Memory Region" for more information. For Am29LVxxxMH: XX18h/18h = Not Factory Locked. XX98h/98h = Factory Locked. For Am29LVxxxML: XX08h/08h = Not Factory Locked. XX88h/88h = Factory Locked.
11. Command is valid when device is ready to read array data or when device is in autoselect mode.
12. The Unlock-Bypass command is required prior to the Unlock-Bypass-Program command.
13. The Unlock-Bypass-Reset command is required to return to reading array data when the device is in the unlock bypass mode.
14. The system may read and program/program suspend in non-erasing sectors, or enter the autoselect mode, when in the Erase Suspend mode. The Erase Suspend command is valid only during a sector erase operation.
15. The Erase Resume/Program Resume command is valid only during the Erase Suspend/Program Suspend modes.
16. Issue this command sequence to return to READ mode after detecting device is in a Write-to-Buffer-Abort state. NOTE: the full command sequence is required if resetting out of ABORT while using Unlock Bypass Mode.
17. S29GL512NH/L = 2223h/23h, 220h/01h; S29GL256NH/L = 2222h/22h, 2201h/01h; S29GL128NH/L = 2221h/21h, 2201h/01h.
18. The Exit command returns the device to reading the array.
19. Note that the password portion can be entered or read in any order as long as the entire 64-bit password is entered or read.
20. For PWD<sub>x</sub>, only one portion of the password can be programmed per each "A0" command.
21. The All PPB Erase command embeds programming of all PPB bits before erasure.
22. All Lock Register bits are one-time programmable. Note that the program state = "0" and the erase state = "1". Also note that of both the Persistent Protection Mode Lock Bit and the Password Protection Mode Lock Bit cannot be programmed at the same time or the Lock Register Bits Program operation will abort and return the device to read mode. Lock Register bits that are reserved for future use will default to "1's". The Lock Register is shipped out as "FFFF's" before Lock Register Bit program execution.
23. If any of the Entry command was initiated, an Exit command must be issued to reset the device into read mode. Otherwise the device will hang.
24. If ACC = V<sub>HH</sub>, sector protection will match when ACC = V<sub>IH</sub>.
25. Protected State = "00h", Unprotected State = "01h".

**Table II. S29GL512N, S29GL256N, S29GLI28N Command Definitions, x8**

Command (Notes)		Cycles	Bus Cycles (Notes 2–5)											
			First		Second		Third		Fourth		Fifth		Sixth	
			Addr	Data	Addr	Data	Addr	Data	Addr	Data	Addr	Data	Addr	Data
Read (6)		1	RA	RD										
Reset (7)		1	XXX	F0										
Autoselect	Manufacturer ID	4	AAA	AA	555	55	AAA	90	X00	01				
	Device ID	4	AAA	AA	555	55	AAA	9	X02	XX7E	X1C	Note 17	X1E	Note 17
	Sector Protect Verify	4	AAA	AA	555	55	AAA	90	(SA) X04	00 01				
	Secure Device Verify (9)	4	AAA	AA	555	55	AAA	90	X06	Note 10				
CFI Query (11)		1	AAA	98										
Write to Buffer		3	AAA	AA	555	55	SA	25	SA	WC	PA	PD	WBL	PD
Program Buffer to Flash (confirm)		1	SA	29										
Write-to-Buffer-Abort Reset (16)		3	AAA	AA	PA	55	555	F0						
Unlock Bypass Reset (13)		2	XXX	90	XXX	00								
Chip Erase		6	AAA	AA	555	55	AAA	80	AAA	AA	555	55	AAA	10
Sector Erase		6	AAA	AA	555	55	AAA	80	AAA	AA	555	55	SA	30
Erase Suspend/Program Suspend (14)		1	XXX	B0										
Erase Resume/Program Resume (15)		1	XXX	30										
<b>Secured Silicon Sector Command Definitions</b>														
Secured Silicon Sector	Secured Silicon Sector Entry	3	AAA	AA	555	55	AAA	88						
	Secured Silicon Sector Exit (18)	4	AAA	AA	555	55	AAA	90	XX	00				
<b>Lock Register Command Set Definitions</b>														
Lock Register	Lock Register Command Set Entry	3	AAA	AA	555	55	AAA	40						
	Lock Register Bits Program (22)	2	XXX	A0	XXX	Data								
	Lock Register Bits Read (22)	1	00	Data										
	Lock Register Command Set Exit (18, 23)	2	XXX	90	XXX	00								
<b>Password Protection Command Set Definitions</b>														

Command (Notes)		Cycles	Bus Cycles (Notes 2-5)											
			First		Second		Third		Fourth		Fifth		Sixth	
			Addr	Data	Addr	Data	Addr	Data	Addr	Data	Addr	Data	Addr	Data
Password	Password Protection Command Set Entry	3	AAA	AA	555	55	AAA	60						
	Password Program (20)	2	XXX	A0	PWA <sub>x</sub>	PWD <sub>x</sub>								
	Password Read (19)	8	00	PWD <sub>0</sub>	01	PWD <sub>1</sub>	02	PWD <sub>2</sub>	03	PWD <sub>3</sub>	04	PWD <sub>4</sub>	05	PWD <sub>5</sub>
			06	PWD <sub>6</sub>	07	PWD <sub>7</sub>								
	Password Unlock (19)	11	00	25	00	03	00	PWD <sub>0</sub>	01	PWD <sub>1</sub>	02	PWD <sub>2</sub>	03	PWD <sub>3</sub>
			04	PWD <sub>4</sub>	05	PWD <sub>5</sub>	06	PWD <sub>6</sub>	07	PWD <sub>7</sub>	00	29		
Password Protection Command Set Exit (18, 23)	2	XXX	90	XXX	00									
<b>Non-Volatile Sector Protection Command Set Definitions</b>														
PPB	Nonvolatile Sector Protection Command Set Entry	3	AAA	AA	55	55	AAA	C0						
	PPB Program (24, 25)	2	XXX	A0	SA	00								
	All PPB Erase	2	XXX	80	00	30								
	PPB Status Read (25)	1	SA	RD (0)										
	Non-Volatile Sector Protection Command Set Exit (18)	2	XXX	90	XXX	00								
<b>Global Non-Volatile Sector Protection Freeze Command Set Definitions</b>														
PPB Lock Bit	Global Non-Volatile Sector Protection Freeze Command Set Entry	3	AAA	AA	555	55	AAA	50						
	PPB Lock Bit Set (25)	2	XXX	A0	XXX	00								
	PPB Lock Status Read (25)	1	XXX	RD (0)										
	Global Non-Volatile Sector Protection Freeze Command Set Exit (18)	2	XXX	90	XXX	00								
<b>Volatile Sector Protection Command Set Definitions</b>														
DYB	Volatile Sector Protection Command Set Entry	3	AAA	AA	555	55	AAA	E0						
	DYB Set (24, 25)	2	XXX	A0	SA	00								
	DYB Clear (25)	2	XXX	A0	SA	01								
	DYB Status Read (25)	1	SA	RD (0)										
	Volatile Sector Protection Command Set Exit (18)	2	XXX	90	XXX	00								

**Legend:**

X = Don't care

RA = Address of the memory to be read.

RD = Data read from location RA during read operation.

PA = Address of the memory location to be programmed. Addresses latch on the falling edge of the WE# or CE# pulse, whichever happens later.

PD = Data to be programmed at location PA. Data latches on the rising edge of the WE# or CE# pulse, whichever happens first.

SA = Address of the sector to be verified (in autoselect mode) or erased. Address bits  $A_{max}$ -A16 uniquely select any sector.

WBL = Write Buffer Location. The address must be within the same write buffer page as PA.

WC = Word Count is the number of write buffer locations to load minus 1.

PWD = Password

$PWD_x$  = Password word0, word1, word2, word3, word 4, word 5, word 6, and word 7.

DATA = Lock Register Contents: PD(0) = Secured Silicon Sector Protection Bit, PD(1) = Persistent Protection Mode Lock Bit, PD(2) = Password Protection Mode Lock Bit.

**Notes:**

1. See Table 1 for description of bus operations.
2. All values are in hexadecimal.
3. Except for the read cycle, and the 4th, 5th, and 6th cycle of the autoselect command sequence, all bus cycles are write cycles.
4. Data bits DQ15-DQ8 are don't cares for unlock and command cycles.
5. Address bits  $A_{MAX}$ :A16 are don't cares for unlock and command cycles, unless SA or PA required. ( $A_{MAX}$  is the Highest Address pin.).
6. No unlock or command cycles required when reading array data.
7. The Reset command is required to return to reading array data when device is in the autoselect mode, or if DQ5 goes high (while the device is providing status data).
8. The fourth, fifth, and sixth cycle of the autoselect command sequence is a read cycle.
9. The data is 00h for an unprotected sector and 01h for a protected sector. See "Autoselect Command Sequence" for more information. This is same as PPB Status Read except that the protect and unprotect statuses are inverted here.
10. The data value for DQ7 is "1" for a serialized and protected OTP region and "0" for an unserialized and unprotected Secured Silicon Sector region. See "Secured Silicon Sector Flash Memory Region" for more information. For Am29LVxxxMH: XX18h/18h = Not Factory Locked. XX98h/98h = Factory Locked. For Am29LVxxxML: XX08h/08h = Not Factory Locked. XX88h/88h = Factory Locked.
11. Command is valid when device is ready to read array data or when device is in autoselect mode.
12. The Unlock-Bypass command is required prior to the Unlock-Bypass-Program command.
13. The Unlock-Bypass-Reset command is required to return to reading array data when the device is in the unlock bypass mode.
14. The system may read and program/program suspend in non-erasing sectors, or enter the autoselect mode, when in the Erase Suspend mode. The Erase Suspend command is valid only during a sector erase operation.
15. The Erase Resume/Program Resume command is valid only during the Erase Suspend/Program Suspend modes.
16. Issue this command sequence to return to READ mode after detecting device is in a Write-to-Buffer-Abort state. NOTE: the full command sequence is required if resetting out of ABORT while using Unlock Bypass Mode.
17. S29GL512NH/L = 2223h/23h, 220h/01h; S29GL256NH/L = 2222h/22h, 2201h/01h; S29GL128NH/L = 2221h/21h, 2201h/01h.
18. The Exit command returns the device to reading the array.
19. Note that the password portion can be entered or read in any order as long as the entire 64-bit password is entered or read.
20. For  $PWD_x$ , only one portion of the password can be programmed per each "A0" command.
21. The All PPB Erase command embeds programming of all PPB bits before erasure.
22. All Lock Register bits are one-time programmable. Note that the program state = "0" and the erase state = "1". Also note that of both the Persistent Protection Mode Lock Bit and the Password Protection Mode Lock Bit cannot be programmed at the same time or the Lock Register Bits Program operation will abort and return the device to read mode. Lock Register bits that are reserved for future use will default to "1"s. The Lock Register is shipped out as "FFFF"s" before Lock Register Bit program execution.
23. If any of the Entry command was initiated, an Exit command must be issued to reset the device into read mode. Otherwise the device will hang.
24. If  $ACC = V_{HH}$ , sector protection will match when  $ACC = V_{IH}$   
Protected State = "00h", Unprotected State = "01h".

## Write Operation Status

The device provides several bits to determine the status of a program or erase operation: DQ2, DQ3, DQ5, DQ6, and DQ7. Table 19 and the following subsections describe the function of these bits. DQ7 and DQ6 each offer a method for determining whether a program or erase operation is complete or in progress.

The device also provides a hardware-based output signal, RY/BY#, to determine whether an Embedded Program or Erase operation is in progress or has been completed.

Note that all Write Operation Status DQ bits are valid only after 4  $\mu$ s delay.

### DQ7: Data# Polling

The Data# Polling bit, DQ7, indicates to the host system whether an Embedded Program or Erase algorithm is in progress or completed, or whether the device is in Erase Suspend. Data# Polling is valid after the rising edge of the final WE# pulse in the command sequence.

During the Embedded Program algorithm, the device outputs on DQ7 the complement of the datum programmed to DQ7. This DQ7 status also applies to programming during Erase Suspend. When the Embedded Program algorithm is complete, the device outputs the datum programmed to DQ7. The system must provide the program address to read valid status information on DQ7. If a program address falls within a protected sector, Data# Polling on DQ7 is active for approximately 1  $\mu$ s, then the device returns to the read mode.

During the Embedded Erase algorithm, Data# Polling produces a "0" on DQ7. When the Embedded Erase algorithm is complete, or if the device enters the Erase Suspend mode, Data# Polling produces a "1" on DQ7. The system must provide an address within any of the sectors selected for erasure to read valid status information on DQ7.

After an erase command sequence is written, if all sectors selected for erasing are protected, Data# Polling on DQ7 is active for approximately 100  $\mu$ s, then the device returns to the read mode. If not all selected sectors are protected, the Embedded Erase algorithm erases the unprotected sectors, and ignores the selected sectors that are protected. However, if the system reads DQ7 at an address within a protected sector, the status may not be valid.

Just prior to the completion of an Embedded Program or Erase operation, DQ7 may change asynchronously with DQ0–DQ6 while Output Enable (OE#) is asserted low. That is, the device may change from providing status information to valid data on DQ7. Depending on when the system samples the DQ7 output, it may read the status or valid data. Even if the device has completed the program or erase operation and DQ7 has valid data, the data outputs on DQ0–DQ6 may be still invalid. Valid data on DQ0–DQ7 will appear on successive read cycles.

Table 12 shows the outputs for Data# Polling on DQ7. Figure 5 shows the Data# Polling algorithm. Figure 17 in the AC Characteristics section shows the Data# Polling timing diagram.

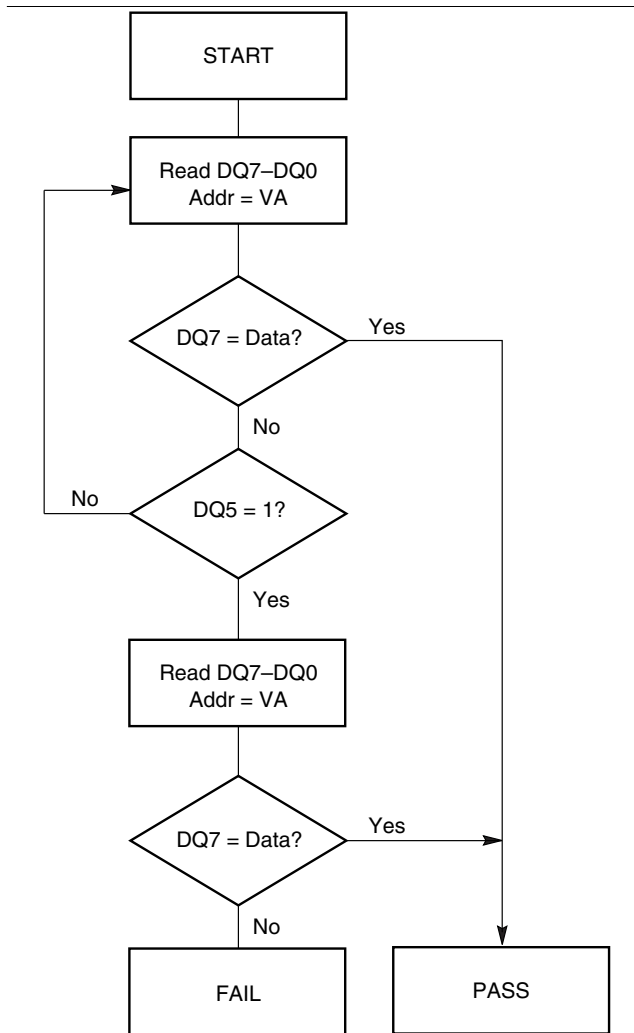

**Notes:**

1. VA = Valid address for programming. During a sector erase operation, a valid address is any sector address within the sector being erased. During chip erase, a valid address is any non-protected sector address.
2. DQ7 should be rechecked even if DQ5 = "1" because DQ7 may change simultaneously with DQ5.

**Figure 5. Data# Polling Algorithm**

**RY/BY#: Ready/Busy#**

The RY/BY# is a dedicated, open-drain output pin which indicates whether an Embedded Algorithm is in progress or complete. The RY/BY# status is valid after the rising edge of the final WE# pulse in the command sequence. Since RY/BY# is an open-drain output, several RY/BY# pins can be tied together in parallel with a pull-up resistor to V<sub>CC</sub>.

If the output is low (Busy), the device is actively erasing or programming. (This includes programming in the Erase Suspend mode.) If the output is high (Ready), the device is in the read mode, the standby mode, or in the erase-suspend-read mode. Table 12 shows the outputs for RY/BY#.

## DQ6: Toggle Bit I

Toggle Bit I on DQ6 indicates whether an Embedded Program or Erase algorithm is in progress or complete, or whether the device has entered the Erase Suspend mode. Toggle Bit I may be read at any address, and is valid after the rising edge of the final WE# pulse in the command sequence (prior to the program or erase operation), and during the sector erase time-out.

During an Embedded Program or Erase algorithm operation, successive read cycles to any address cause DQ6 to toggle. The system may use either OE# or CE# to control the read cycles. When the operation is complete, DQ6 stops toggling.

After an erase command sequence is written, if all sectors selected for erasing are protected, DQ6 toggles for approximately 100  $\mu$ s, then returns to reading array data. If not all selected sectors are protected, the Embedded Erase algorithm erases the unprotected sectors, and ignores the selected sectors that are protected.

The system can use DQ6 and DQ2 together to determine whether a sector is actively erasing or is erase-suspended. When the device is actively erasing (that is, the Embedded Erase algorithm is in progress), DQ6 toggles. When the device enters the Erase Suspend mode, DQ6 stops toggling. However, the system must also use DQ2 to determine which sectors are erasing or erase-suspended. Alternatively, the system can use DQ7 (see the subsection on DQ7: Data# Polling).

If a program address falls within a protected sector, DQ6 toggles for approximately 1  $\mu$ s after the program command sequence is written, then returns to reading array data.

DQ6 also toggles during the erase-suspend-program mode, and stops toggling once the Embedded Program algorithm is complete.

Table 12 shows the outputs for Toggle Bit I on DQ6. Figure 6 shows the toggle bit algorithm. Figure 18 in the "AC Characteristics" section shows the toggle bit tim-



ing diagrams. Figure 19 shows the differences between DQ2 and DQ6 in graphical form. See also the subsection on DQ2: Toggle Bit II.

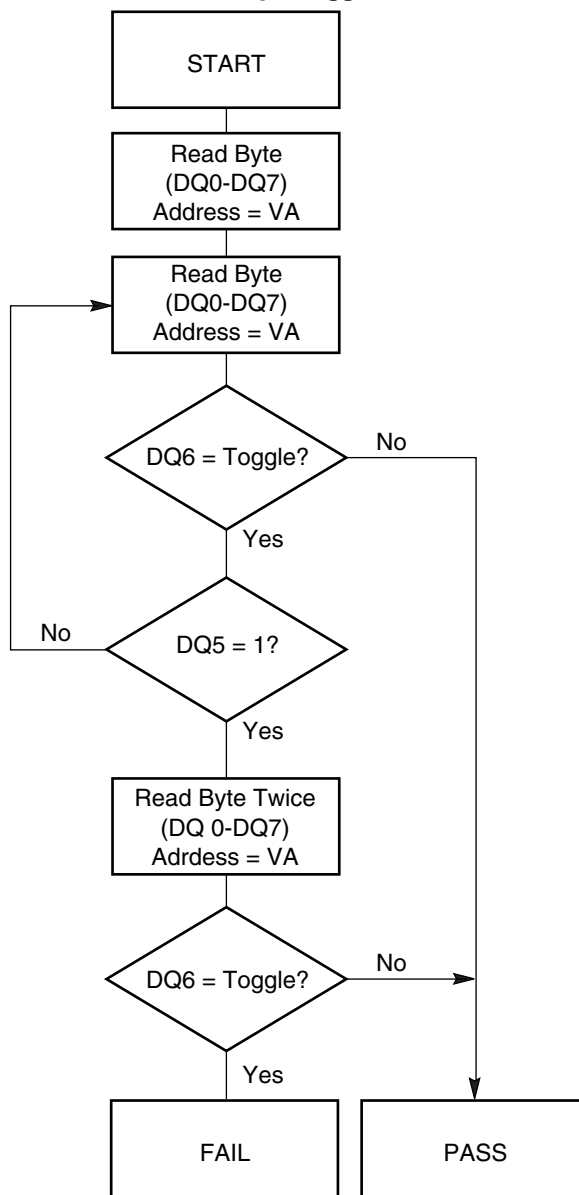

**Note:** The system should recheck the toggle bit even if DQ5 = “1” because the toggle bit may stop toggling as DQ5 changes to “1.” See the subsections on DQ6 and DQ2 for more information.

**Figure 6. Toggle Bit Algorithm**

### DQ2: Toggle Bit II

The “Toggle Bit II” on DQ2, when used with DQ6, indicates whether a particular sector is actively erasing (that is, the Embedded Erase algorithm is in progress), or whether that sector is erase-suspended. Toggle Bit II is valid after the rising edge of the final WE# pulse in the command sequence.

DQ2 toggles when the system reads at addresses within those sectors that have been selected for erasure. (The system may use either OE# or CE# to control the read cycles.) But DQ2 cannot distinguish whether the sector is actively erasing or is erase-suspended. DQ6, by comparison, indicates whether the device is actively erasing, or is in Erase Suspend, but cannot distinguish which sectors are selected for erasure. Thus, both status bits are required for sector and mode information. Refer to Table 12 to compare outputs for DQ2 and DQ6.

Figure 6 shows the toggle bit algorithm in flowchart form, and the section "DQ2: Toggle Bit II" explains the algorithm. See also the RY/BY#: Ready/Busy# subsection. Figure 18 shows the toggle bit timing diagram. Figure 19 shows the differences between DQ2 and DQ6 in graphical form.

### Reading Toggle Bits DQ6/DQ2

Refer to Figure 6 for the following discussion. Whenever the system initially begins reading toggle bit status, it must read DQ7–DQ0 at least twice in a row to determine whether a toggle bit is toggling. Typically, the system would note and store the value of the toggle bit after the first read. After the second read, the system would compare the new value of the toggle bit with the first. If the toggle bit is not toggling, the device has completed the program or erase operation. The system can read array data on DQ7–DQ0 on the following read cycle.

However, if after the initial two read cycles, the system determines that the toggle bit is still toggling, the system also should note whether the value of DQ5 is high (see the section on DQ5). If it is, the system should then determine again whether the toggle bit is toggling, since the toggle bit may have stopped toggling just as DQ5 went high. If the toggle bit is no longer toggling, the device has successfully completed the program or erase operation. If it is still toggling, the device did not complete the operation successfully, and the system must write the reset command to return to reading array data.

The remaining scenario is that the system initially determines that the toggle bit is toggling and DQ5 has not gone high. The system may continue to monitor the toggle bit and DQ5 through successive read cycles, determining the status as described in the previous paragraph. Alternatively, it may choose to perform other system tasks. In this case, the system must start at the beginning of the algorithm when it returns to determine the status of the operation (top of Figure 6).

### DQ5: Exceeded Timing Limits

DQ5 indicates whether the program, erase, or write-to-buffer time has exceeded a specified internal pulse count limit. Under these conditions DQ5 produces a "1," indicating that the program or erase cycle was not successfully completed.

The device may output a "1" on DQ5 if the system tries to program a "1" to a location that was previously programmed to "0." **Only an erase operation can change a "0" back to a "1."** Under this condition, the device halts the operation, and when the timing limit has been exceeded, DQ5 produces a "1."

In all these cases, the system must write the reset command to return the device to the reading the array (or to erase-suspend-read if the device was previously in the erase-suspend-program mode).

### **DQ3: Sector Erase Timer**

After writing a sector erase command sequence, the system may read DQ3 to determine whether or not erasure has begun. (The sector erase timer does not apply to the chip erase command.) If additional sectors are selected for erasure, the entire time-out also applies after each additional sector erase command. When the time-out period is complete, DQ3 switches from a "0" to a "1." If the time between additional sector erase commands from the system can be assumed to be less than 50  $\mu$ s, the system need not monitor DQ3. See also the Sector Erase Command Sequence section.

After the sector erase command is written, the system should read the status of DQ7 (Data# Polling) or DQ6 (Toggle Bit I) to ensure that the device has accepted the command sequence, and then read DQ3. If DQ3 is "1," the Embedded Erase algorithm has begun; all further commands (except Erase Suspend) are ignored until the erase operation is complete. If DQ3 is "0," the device will accept additional sector erase commands. To ensure the command has been accepted, the system software should check the status of DQ3 prior to and following each subsequent sector erase command. If DQ3 is high on the second status check, the last command might not have been accepted.

Table 12 shows the status of DQ3 relative to the other status bits.

### **DQ1: Write-to-Buffer Abort**

DQ1 indicates whether a Write-to-Buffer operation was aborted. Under these conditions DQ1 produces a "1". The system must issue the Write-to-Buffer-Abort-Reset command sequence to return the device to reading array data. See Write Buffer section for more details.

**Table 12. Write Operation Status**

Status		DQ7 (Note 2)	DQ6	DQ5 (Note 1)	DQ3	DQ2 (Note 2)	DQ1	RY/ BY#
Standard Mode	Embedded Program Algorithm	DQ7#	Toggle	0	N/A	No toggle	0	0
	Embedded Erase Algorithm	0	Toggle	0	1	Toggle	N/A	0
Program Suspend Mode	Program-Suspend Sector	Invalid (not allowed)						1
	Non-Program Suspend Sector	Data						1
Erase Suspend Mode	Erase-Suspend Sector	1	No toggle	0	N/A	Toggle	N/A	1
	Non-Erase Suspend Sector	Data						1
	Erase-Suspend-Program (Embedded Program)	DQ7#	Toggle	0	N/A	N/A	N/A	0
Write-to-Buffer	Busy (Note 3)	DQ7#	Toggle	0	N/A	N/A	0	0
	Abort (Note 4)	DQ7#	Toggle	0	N/A	N/A	1	0

**Notes:**

1. DQ5 switches to '1' when an Embedded Program, Embedded Erase, or Write-to-Buffer operation has exceeded the maximum timing limits. Refer to the section on DQ5 for more information.
2. DQ7 and DQ2 require a valid address when reading status information. Refer to the appropriate subsection for further details.
3. The Data# Polling algorithm should be used to monitor the last loaded write-buffer address location.
4. DQ1 switches to '1' when the device has aborted the write-to-buffer operation

**Absolute Maximum Ratings**

Storage Temperature, Plastic Packages . . . . . -65°C to +150°C  
 Ambient Temperature with Power Applied . . . . . -65°C to +125°C  
 Voltage with Respect to Ground:  
     V<sub>CC</sub> (Note 1) . . . . . -0.5 V to +4.0 V  
     V<sub>IO</sub> . . . . . -0.5 V to +4.0 V  
     A9, OE#, ACC and RESET# (Note 2) . . . . . -0.5 V to +12.5 V  
     All other pins (Note 1) . . . . . -0.5 V to V<sub>CC</sub>+12.5 V  
 Output Short Circuit Current (Note 3) . . . . . 200 mA

**Notes:**

1. Minimum DC voltage on input or I/Os is -0.5 V. During voltage transitions, inputs or I/Os may overshoot V<sub>SS</sub> to -2.0 V for periods of up to 20 ns. See [Figure 7](#). Maximum DC voltage on input or I/Os is V<sub>CC</sub> + 0.5 V. During voltage transitions, input or I/O pins may overshoot to V<sub>CC</sub> + 2.0 V for periods up to 20 ns. See [Figure 8](#).
2. Minimum DC input voltage on pins A9, OE#, ACC, and RESET# is -0.5 V. During voltage transitions, A9, OE#, ACC, and RESET# may overshoot V<sub>SS</sub> to -2.0 V for periods of up to 20 ns. See [Figure 7](#). Maximum DC input voltage on pin A9, OE#, ACC, and RESET# is +12.5 V which may overshoot to +14.0V for periods up to 20 ns.
3. No more than one output may be shorted to ground at a time. Duration of the short circuit should not be greater than one second.
4. Stresses above those listed under "Absolute Maximum Ratings" may cause permanent damage to the device. This is a stress rating only; functional operation

of the device at these or any other conditions above those indicated in the operational sections of this data sheet is not implied. Exposure of the device to absolute maximum rating conditions for extended periods may affect device reliability.

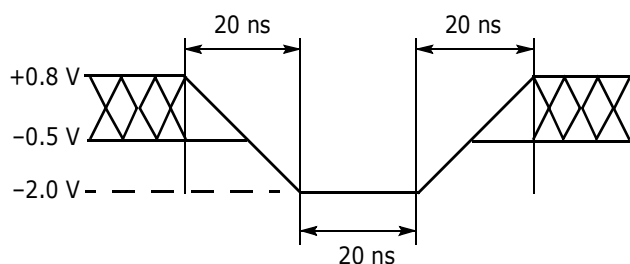

**Figure 7. Maximum Negative Overshoot Waveform**

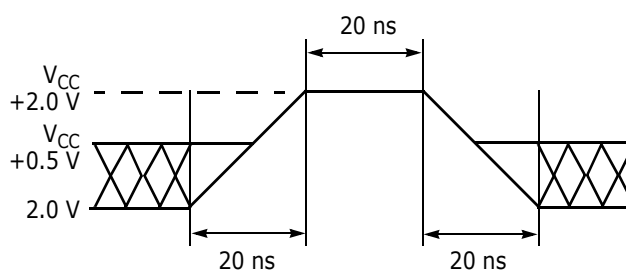

**Figure 8. Maximum Positive Overshoot Waveform**

## Operating Ranges

### Industrial (I) Devices

Ambient Temperature ( $T_A$ ) . . . . .  $-40^{\circ}\text{C}$  to  $+85^{\circ}\text{C}$

### Supply Voltages

$V_{CC}$  . . . . .  $+2.7\text{ V}$  to  $+3.6\text{ V}$

$V_{IO}$  (Note 2) . . . . .  $+1.65\text{ V}$  to  $+1.95\text{ V}$  or  $+2.7$  to  $3.6\text{ V}$

### Notes:

1. Operating ranges define those limits between which the functionality of the device is guaranteed.
2. The I/Os will not operate at 3 V when  $V_{IO}=1.8\text{ V}$ .

## DC Characteristics

### CMOS Compatible

Parameter Symbol	Parameter Description (Notes)	Test Conditions	Min	Typ	Max	Unit
$I_{LI}$	Input Load Current (1)	$V_{IN} = V_{SS}$ to $V_{CC}$ , $V_{CC} = V_{CCmax}$			$\pm 1.0$	$\mu A$
$I_{LIT}$	A9 Input Load Current	$V_{CC} = V_{CCmax}$ ; A9 = 12.5 V			35	$\mu A$
$I_{LO}$	Output Leakage Current	$V_{OUT} = V_{SS}$ to $V_{CC}$ , $V_{CC} = V_{CCmax}$			$\pm 1.0$	$\mu A$
$I_{IO1}$	$V_{IO}$ Active Read Current (Switching Current)	$V_{IO} = 1.8$ V, CE# = $V_{IL}$ , OE# = $V_{IL}$ , WE# = $V_{IL}$ , $f = 5$ MHz		5	10	$\mu A$
$I_{IO2}$	$V_{IO}$ Non-Active Output	CE# = $V_{IL}$ , OE# = $V_{IH}$		0.2	10	mA
$I_{CC1}$	$V_{CC}$ Active Read Current (1)	CE# = $V_{IL}$ , OE# = $V_{IH}$ , $V_{CC} = V_{CCmax}$ , $f = 5$ MHz, Byte Mode		25	30	mA
		CE# = $V_{IL}$ , OE# = $V_{IH}$ , $V_{CC} = V_{CCmax}$ , $f = 5$ MHz, Word Mode		25	30	
$I_{CC2}$	$V_{CC}$ Initial Page Read Current (1)	CE# = $V_{IL}$ , OE# = $V_{IH}$ , $V_{CC} = V_{CCmax}$		50	60	mA
$I_{CC3}$	$V_{CC}$ Intra-Page Read Current (1)	CE# = $V_{IL}$ , OE# = $V_{IH}$ , $V_{CC} = V_{CCmax}$		10	20	mA
$I_{CC4}$	$V_{CC}$ Active Erase/Program Current (2, 3)	CE# = $V_{IL}$ , OE# = $V_{IH}$ , $V_{CC} = V_{CCmax}$		50	60	mA
$I_{CC5}$	$V_{CC}$ Standby Current	CE#, RESET# = $V_{SS} \pm 0.3$ V, OE# = $V_{IH}$ , $V_{CC} = V_{CCmax}$		1	5	$\mu A$
$I_{CC6}$	$V_{CC}$ Reset Current	$V_{CC} = V_{CCmax}$ ; RESET# = $V_{SS} \pm 0.3$ V		1	5	$\mu A$
$I_{CC7}$	Automatic Sleep Mode (4)	$V_{CC} = V_{CCmax}$ , $V_{IH} = V_{CC} \pm 0.3$ V, $V_{IL} = V_{SS} \pm 0.3$ V, WP#/ACC = $V_{IH}$		1	5	$\mu A$
$I_{ACC}$	ACC Accelerated Program Current	CE# = $V_{IL}$ , OE# = $V_{IH}$ , $V_{CC} = V_{CCmax}$ , WP#/ACC = $V_{IH}$	WP#/ACC pin	10	20	mA
			$V_{CC}$ pin	30	60	
$V_{IL}$	Input Low Voltage (5)		-0.5		$0.3 \times V_{IO}$	V
$V_{IH}$	Input High Voltage (5)		$0.7 \times V_{IO}$		$V_{IO} + 0.3$	V
$V_{HH}$	Voltage for ACC Erase/Program Acceleration	$V_{CC} = 2.7 - 3.6$ V	11.5		12.5	V
$V_{ID}$	Voltage for Autoselect and Temporary Sector Unprotect	$V_{CC} = 2.7 - 3.6$ V	11.5		12.5	V
$V_{OL}$	Output Low Voltage (5)	$I_{OL} = 100 \mu A$			$0.15 \times V_{IO}$	V
$V_{OH}$	Output High Voltage (5)	$I_{OH} = 100 \mu A$	$0.85 \times V_{IO}$			V
$V_{LKO}$	Low $V_{CC}$ Lock-Out Voltage (3)		2.3		2.5	V

#### Notes:

1. The  $I_{CC}$  current listed is typically less than TBD mA/MHz, with OE# at  $V_{IH}$ .
2.  $I_{CC}$  active while Embedded Erase or Embedded Program or Write Buffer Programming is in progress.
3. Not 100% tested.
4. Automatic sleep mode enables the lower power mode when addresses remain stable for  $t_{ACC} + 30$  ns.
5.  $V_{IO} = 1.65 - 3.6$  V
6.  $V_{CC} = 3$  V and  $V_{IO} = 3$  V or 1.8V. When  $V_{IO}$  is at 1.8V, I/O pins cannot operate at 3V.

## Test Conditions

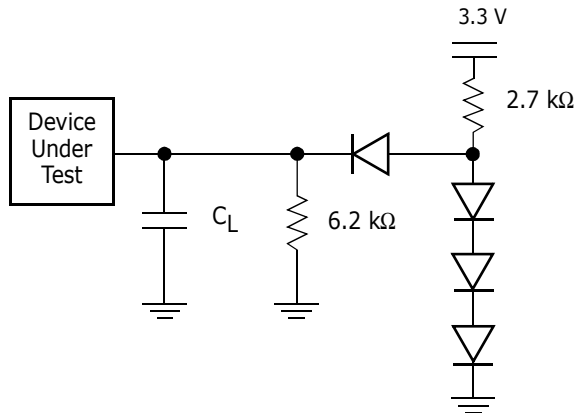

**Note:** Diodes are IN3064 or equivalent.

**Figure 9. Test Setup**

**Table I3. Test Specifications**

Test Condition	All Speeds	Unit
Output Load	1 TTL gate	
Output Load Capacitance, $C_L$ (including jig capacitance)	30	pF
Input Rise and Fall Times	5	ns
Input Pulse Levels	$0.0-V_{IO}$	V
Input timing measurement reference levels (See Note)	$0.5V_{IO}$	V
Output timing measurement reference levels	$0.5 V_{IO}$	V

**Note:** Diodes are IN3064 or equivalent

**Note:** If  $V_{IO} < V_{CC}$ , the reference level is  $0.5 V_{IO}$ .

## Key to Switching Waveforms

Waveform	Inputs	Outputs
	Steady	
	Changing from H to L	
	Changing from L to H	
	Don't Care, Any Change Permitted	Changing, State Unknown
	Does Not Apply	Center Line is High Impedance State (High Z)

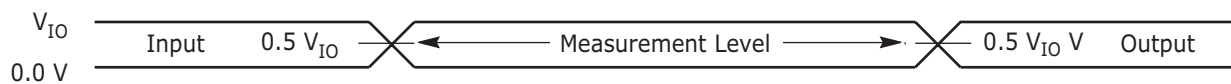

**Note:** If  $V_{IO} < V_{CC}$ , the input measurement reference level is  $0.5 V_{IO}$ .

**Figure 10. Input Waveforms and Measurement Levels**

## AC Characteristics

### Read-Only Operations—S29GL512N Only

Parameter		Description	Test Setup	Speed Options				Unit	
JEDEC	Std.			90	100	100	110		
t <sub>AVAV</sub>	t <sub>RC</sub>	Read Cycle Time	V <sub>IO</sub> = V <sub>CC</sub> = 3 V	Min	90	100			ns
			V <sub>IO</sub> = 2.5 V, V <sub>CC</sub> = 3 V (Note 1)		100	110			
			V <sub>IO</sub> = 1.8 V, V <sub>CC</sub> = 3 V				100	110	ns
t <sub>AVQV</sub>	t <sub>ACC</sub>	Address to Output Delay (Note 2)	V <sub>IO</sub> = V <sub>CC</sub> = 3 V	Max	90	100			ns
			V <sub>IO</sub> = 2.5 V, V <sub>CC</sub> = 3 V (Note 1)		100	110			
			V <sub>IO</sub> = 1.8 V, V <sub>CC</sub> = 3 V				100	110	ns
t <sub>ELQV</sub>	t <sub>CE</sub>	Chip Enable to Output Delay (Note 3)	V <sub>IO</sub> = V <sub>CC</sub> = 3 V	Max	90	105			ns
			V <sub>IO</sub> = 2.5 V, V <sub>CC</sub> = 3 V (Note 1)		100	110			
			V <sub>IO</sub> = 1.8 V, V <sub>CC</sub> = 3 V				100	110	ns
	t <sub>PAC C</sub>	Page Access Time		Max	25	25	35	35	ns
t <sub>GLQV</sub>	t <sub>OE</sub>	Output Enable to Output Delay		Max	25	25	35	35	ns
t <sub>EHQZ</sub>	t <sub>DF</sub>	Chip Enable to Output High Z (Note 1)		Max	20				ns
t <sub>GHQZ</sub>	t <sub>DF</sub>	Output Enable to Output High Z (Note 1)		Max	20				ns
t <sub>AXQX</sub>	t <sub>OH</sub>	Output Hold Time From Addresses, CE# or OE#, Whichever Occurs First		Min	0				ns
	t <sub>OEh</sub>	Output Enable Hold Time (Note 1)	Read	Min	0				ns
			Toggle and Data# Polling	Min	10				ns

**Notes:**

1. Not 100% tested.
2. CE#, OE# = V<sub>IL</sub>
3. OE# = V<sub>IL</sub>
4. See Figure 9 and Table 13 for test specifications.
5. Unless otherwise indicated, AC specifications for 90 ns and 100 ns speed options are tested with V<sub>IO</sub> = V<sub>CC</sub> = 3 V. AC specifications for 100 ns and 110 ns speed options are tested with V<sub>IO</sub> = 1.8 V and V<sub>CC</sub> = 3.0 V.



## AC Characteristics

### Read-Only Operations—S29GL256N Only

Parameter		Description	Test Setup		Speed Options				Unit
JEDEC	Std.				80	90	90	100	
$t_{AVAV}$	$t_{RC}$	Read Cycle Time	$V_{IO} = V_{CC} = 3\text{ V}$	Min	80	90			ns
			$V_{IO} = 2.5\text{ V}, V_{CC} = 3\text{ V}$ (Note 1)		90	100			
			$V_{IO} = 1.8\text{ V}, V_{CC} = 3\text{ V}$				90	100	
$t_{AVQV}$	$t_{ACC}$	Address to Output Delay (Note 2)	$V_{IO} = V_{CC} = 3\text{ V}$	Max	80	90			ns
			$V_{IO} = 2.5\text{ V}, V_{CC} = 3\text{ V}$ (Note 1)		90	100			
			$V_{IO} = 1.8\text{ V}, V_{CC} = 3\text{ V}$				90	100	
$t_{ELQV}$	$t_{CE}$	Chip Enable to Output Delay (Note 3)	$V_{IO} = V_{CC} = 3\text{ V}$	Max	80	90			ns
			$V_{IO} = 2.5\text{ V}, V_{CC} = 3\text{ V}$ (Note 1)		90	100			
			$V_{IO} = 1.8\text{ V}, V_{CC} = 3\text{ V}$				90	100	
	$t_{PAC}$ C	Page Access Time		Max	25	25	35	35	ns
$t_{GLQV}$	$t_{OE}$	Output Enable to Output Delay		Max	25	25	35	35	ns
$t_{EHQZ}$	$t_{DF}$	Chip Enable to Output High Z (Note 1)		Max	20			ns	
$t_{GHQZ}$	$t_{DF}$	Output Enable to Output High Z (Note 1)		Max	20			ns	
$t_{AXQX}$	$t_{OH}$	Output Hold Time From Addresses, CE# or OE#, Whichever Occurs First		Min	0			ns	
	$t_{OEH}$	Output Enable Hold Time (Note 1)	Read	Min	0			ns	
			Toggle and Data# Polling	Min	10			ns	

**Notes:**

1. Not 100% tested.
2. CE#, OE# =  $V_{IL}$
3. OE# =  $V_{IL}$
4. See Figure 9 and Table 13 for test specifications.
5. Unless otherwise indicated, AC specifications for 80 ns and 90 ns speed options are tested with  $V_{IO} = V_{CC} = 3\text{ V}$ . AC specifications for 90 ns and 100 ns speed options are tested with  $V_{IO} = 1.8\text{ V}$  and  $V_{CC} = 3.0\text{ V}$ .

## AC Characteristics

### Read-Only Operations—S29GLI28N Only

Parameter		Description	Test Setup		Speed Options				Unit
JEDEC	Std.				80	90	90	100	
t <sub>AVAV</sub>	t <sub>RC</sub>	Read Cycle Time	V <sub>IO</sub> = V <sub>CC</sub> = 3 V	Min	80	90			ns
			V <sub>IO</sub> = 2.5 V, V <sub>CC</sub> = 3 V (Note 1)		90	100			
			V <sub>IO</sub> = 1.8 V, V <sub>CC</sub> = 3 V				90	100	
t <sub>AVQV</sub>	t <sub>ACC</sub>	Address to Output Delay (Note 2)	V <sub>IO</sub> = V <sub>CC</sub> = 3 V	Max	80	90			ns
			V <sub>IO</sub> = 2.5 V, V <sub>CC</sub> = 3 V (Note 1)		90	100			
			V <sub>IO</sub> = 1.8 V, V <sub>CC</sub> = 3 V				90	100	
t <sub>ELQV</sub>	t <sub>CE</sub>	Chip Enable to Output Delay (Note 3)	V <sub>IO</sub> = V <sub>CC</sub> = 3 V	Max	80	90			ns
			V <sub>IO</sub> = 2.5 V, V <sub>CC</sub> = 3 V (Note 1)		90	100			
			V <sub>IO</sub> = 1.8 V, V <sub>CC</sub> = 3 V				90	100	
	t <sub>PAC</sub> C	Page Access Time		Max	25	25	35	35	ns
t <sub>GLQV</sub>	t <sub>OE</sub>	Output Enable to Output Delay		Max	25	25	35	35	ns
t <sub>EHQZ</sub>	t <sub>DF</sub>	Chip Enable to Output High Z (Note 1)		Max	20			ns	
t <sub>GHQZ</sub>	t <sub>DF</sub>	Output Enable to Output High Z (Note 1)		Max	20			ns	
t <sub>AXQX</sub>	t <sub>OH</sub>	Output Hold Time From Addresses, CE# or OE#, Whichever Occurs First		Min	0			ns	
	t <sub>OEH</sub>	Output Enable Hold Time (Note 1)	Read	Min	0			ns	
			Toggle and Data# Polling	Min	10			ns	

**Notes:**

1. Not 100% tested.
2. CE#, OE# = V<sub>IL</sub>
3. OE# = V<sub>IL</sub>
4. See Figure 9 and Table 13 for test specifications.
5. Unless otherwise indicated, AC specifications for 80 ns and 90 ns speed options are tested with V<sub>IO</sub> = V<sub>CC</sub> = 3 V. AC specifications for 90 ns and 100 ns speed options are tested with V<sub>IO</sub> = 1.8 V and V<sub>CC</sub> = 3.0 V.

## AC Characteristics

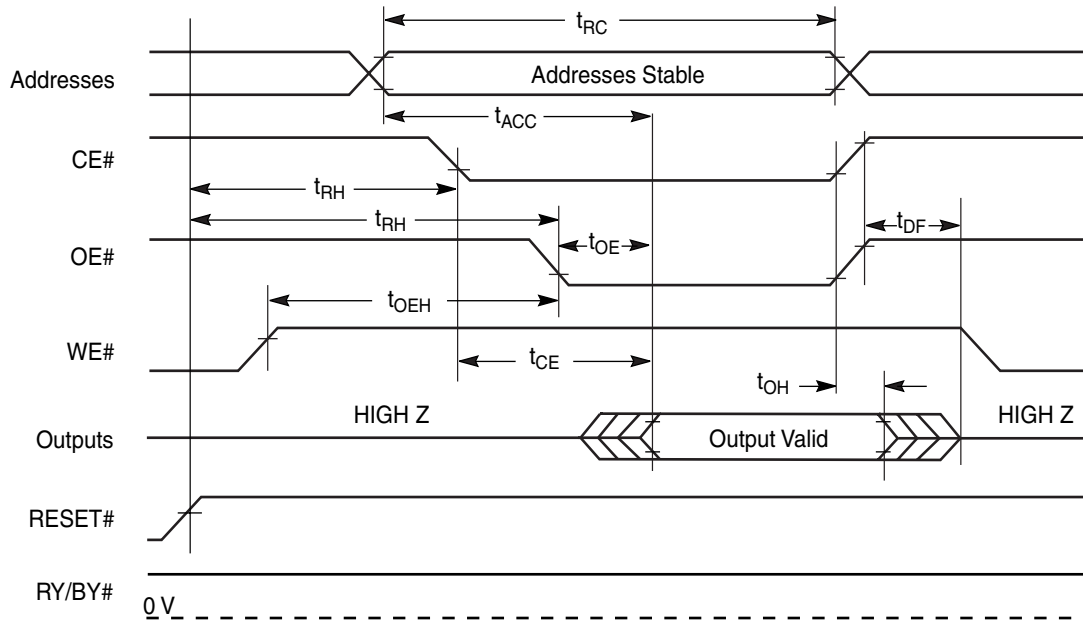
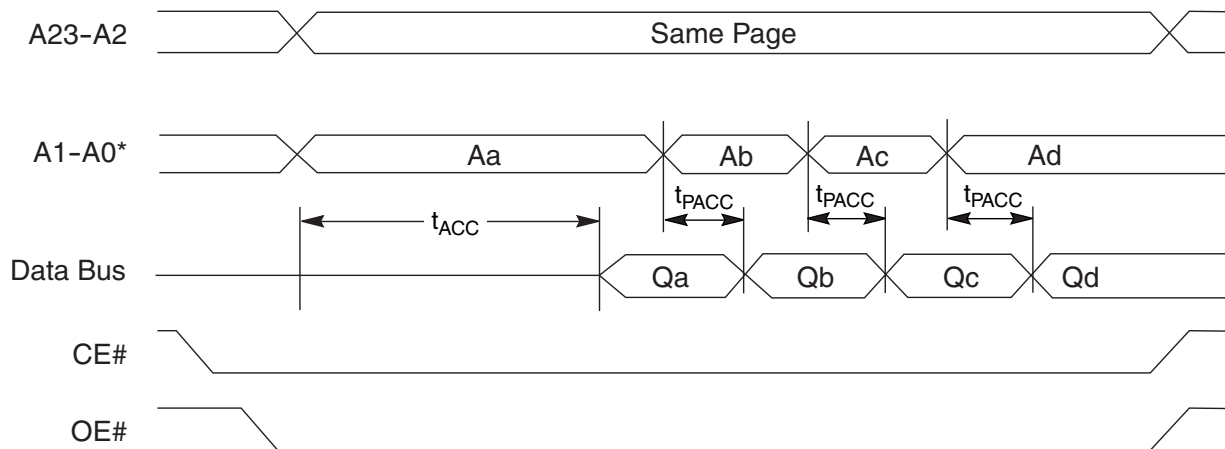

Figure II. Read Operation Timings



**Note:** Figure shows word mode. Addresses are A2-A-1 for byte mode.

Figure I2. Page Read Timings

## AC Characteristics

### Hardware Reset (RESET#)

Parameter		Description		All Speed Options	Unit
JEDEC	Std.				
	$t_{Ready}$	RESET# Pin Low (During Embedded Algorithms) to Read Mode (See Note)	Max	1	ms
	$t_{Ready}$	RESET# Pin Low (NOT During Embedded Algorithms) to Read Mode (See Note)	Max	1	ms
	$t_{RP}$	RESET# Pulse Width	Min	1	ms
	$t_{RH}$	Reset High Time Before Read (See Note)	Min	50	ns
	$t_{RPD}$	RESET# Low to Standby Mode	Min	20	$\mu$ s
	$t_{RB}$	RY/BY# Recovery Time	Min	0	ns

**Note:** Not 100% tested. If ramp rate is equal to or faster than 1V/100 $\mu$ s with a falling edge of the RESET# pin initiated, the RESET# pin needs to be held low only for 100 $\mu$ s for power-up.

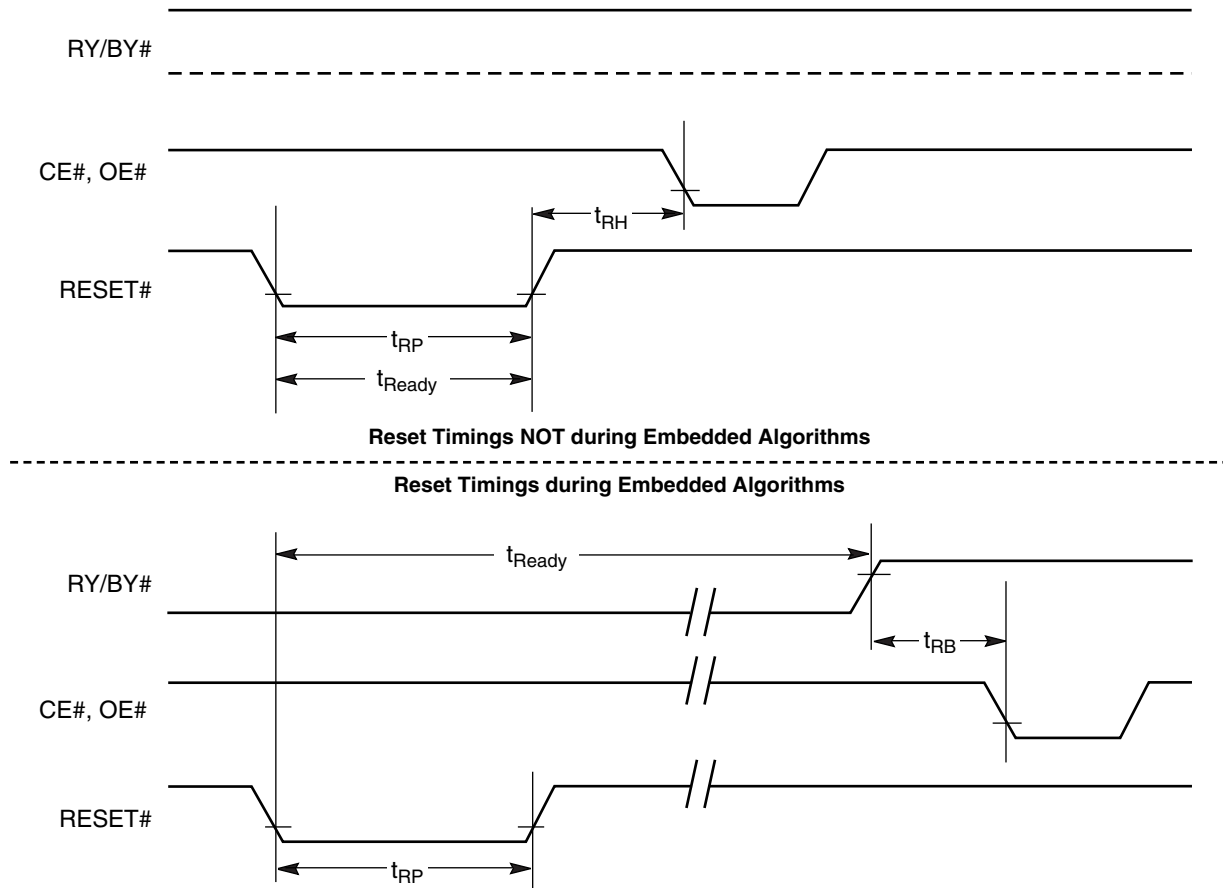

Figure I3. Reset Timings

## AC Characteristics

### Erase and Program Operations—S29GL512N Only

Parameter		Description		Speed Options				Unit
JEDEC	Std.			90	100	100	110	
t <sub>AVAV</sub>	t <sub>WC</sub>	Write Cycle Time (Note 1)	Min	90	100	100	110	ns
t <sub>AVWL</sub>	t <sub>AS</sub>	Address Setup Time	Min	0				ns
	t <sub>ASO</sub>	Address Setup Time to OE# low during toggle bit polling	Min	15				ns
t <sub>WLAX</sub>	t <sub>AH</sub>	Address Hold Time	Min	45				ns
	t <sub>AHT</sub>	Address Hold Time From CE# or OE# high during toggle bit polling	Min	0				ns
t <sub>DVWH</sub>	t <sub>DS</sub>	Data Setup Time	Min	45				ns
t <sub>WHDX</sub>	t <sub>DH</sub>	Data Hold Time	Min	0				ns
	t <sub>OEPH</sub>	Output Enable High during toggle bit polling	Min	20				ns
t <sub>GHWL</sub>	t <sub>GHWL</sub>	Read Recovery Time Before Write (OE# High to WE# Low)	Min	0				ns
t <sub>ELWL</sub>	t <sub>CS</sub>	CE# Setup Time	Min	0				ns
t <sub>WHEH</sub>	t <sub>CH</sub>	CE# Hold Time	Min	0				ns
t <sub>WLWH</sub>	t <sub>WP</sub>	Write Pulse Width	Min	35				ns
t <sub>WHDL</sub>	t <sub>WPH</sub>	Write Pulse Width High	Min	30				ns
t <sub>WHWH1</sub>	t <sub>WHWH1</sub>	Write Buffer Program Operation (Notes 2, 3)		Typ	TBD			µs
		Effective Write Buffer Program Operation (Notes 2, 4)	Per Word	Typ	TBD			µs
		Accelerated Effective Write Buffer Program Operation (Notes 2, 4)	Per Word	Typ	TBD			µs
		Program Operation (Note 2)	Word	Typ	TBD			µs
		Accelerated Programming Operation (Note 2)	Word	Typ	TBD			µs
t <sub>WHWH2</sub>	t <sub>WHWH2</sub>	Sector Erase Operation (Note 2)		Typ	TBD			sec
	t <sub>VHH</sub>	V <sub>HH</sub> Rise and Fall Time (Note 1)		Min	250			ns
	t <sub>VCS</sub>	V <sub>CC</sub> Setup Time (Note 1)		Min	50			µs

**Notes:**

1. Not 100% tested.
2. See the "AC Characteristics" section for more information.
3. For 1-16 words/1-32 bytes programmed.
4. Effective write buffer specification is based upon a 16-word/32-byte write buffer operation.
5. Unless otherwise indicated, AC specifications for 90 ns and 100 ns speed options are tested with V<sub>IO</sub> = V<sub>CC</sub> = 3 V. AC specifications for 100 ns and 110 ns speed options are tested with V<sub>IO</sub> = 1.8 V and V<sub>CC</sub> = 3.0 V.

## AC Characteristics

### Erase and Program Operations—S29GL256N Only

Parameter		Description		Speed Options				Unit	
JEDEC	Std.			80	90	90	100		
t <sub>AVAV</sub>	t <sub>WC</sub>	Write Cycle Time (Note 1)	Min	80	90	90	100	ns	
t <sub>AVWL</sub>	t <sub>AS</sub>	Address Setup Time	Min	0				ns	
	t <sub>ASO</sub>	Address Setup Time to OE# low during toggle bit polling	Min	15				ns	
t <sub>WLAX</sub>	t <sub>AH</sub>	Address Hold Time	Min	45				ns	
	t <sub>AHT</sub>	Address Hold Time From CE# or OE# high during toggle bit polling	Min	0				ns	
t <sub>DVWH</sub>	t <sub>DS</sub>	Data Setup Time	Min	45				ns	
t <sub>WHDX</sub>	t <sub>DH</sub>	Data Hold Time	Min	0				ns	
	t <sub>OEPH</sub>	Output Enable High during toggle bit polling	Min	20				ns	
t <sub>GHWL</sub>	t <sub>GHWL</sub>	Read Recovery Time Before Write (OE# High to WE# Low)	Min	0				ns	
t <sub>ELWL</sub>	t <sub>CS</sub>	CE# Setup Time	Min	0				ns	
t <sub>WHEH</sub>	t <sub>CH</sub>	CE# Hold Time	Min	0				ns	
t <sub>WLWH</sub>	t <sub>WP</sub>	Write Pulse Width	Min	35				ns	
t <sub>WHDL</sub>	t <sub>WPH</sub>	Write Pulse Width High	Min	30				ns	
t <sub>WHWH1</sub>	t <sub>WHWH1</sub>	Write Buffer Program Operation (Notes 2, 3)		Typ	TBD				μs
		Effective Write Buffer Program Operation (Notes 2, 4)	Per Word	Typ	TBD				μs
		Accelerated Effective Write Buffer Program Operation (Notes 2, 4)	Per Word	Typ	TBD				μs
		Program Operation (Note 2)	Word	Typ	TBD				μs
		Accelerated Programming Operation (Note 2)	Word	Typ	TBD				μs
t <sub>WHWH2</sub>	t <sub>WHWH2</sub>	Sector Erase Operation (Note 2)		Typ	TBD				sec
	t <sub>VHH</sub>	V <sub>HH</sub> Rise and Fall Time (Note 1)		Min	250				ns
	t <sub>VCS</sub>	V <sub>CC</sub> Setup Time (Note 1)		Min	50				μs

**Notes:**

1. Not 100% tested.
2. See the "AC Characteristics" section for more information.
3. For 1-16 words/1-32 bytes programmed.
4. Effective write buffer specification is based upon a 16-word/32-byte write buffer operation.
5. Unless otherwise indicated, AC specifications for 80 ns and 90 ns speed options are tested with V<sub>IO</sub> = V<sub>CC</sub> = 3 V. AC specifications for 90 ns and 100 ns speed options are tested with V<sub>IO</sub> = 1.8 V and V<sub>CC</sub> = 3.0 V.

## AC Characteristics

### Erase and Program Operations—S29GLI28N Only

Parameter		Description		Speed Options				Unit	
JEDEC	Std.			80	90	90	100		
t <sub>AVAV</sub>	t <sub>WC</sub>	Write Cycle Time (Note 1)	Min	80	90	90	100	ns	
t <sub>AVWL</sub>	t <sub>AS</sub>	Address Setup Time	Min	0				ns	
	t <sub>ASO</sub>	Address Setup Time to OE# low during toggle bit polling	Min	15				ns	
t <sub>WLAX</sub>	t <sub>AH</sub>	Address Hold Time	Min	45				ns	
	t <sub>AHT</sub>	Address Hold Time From CE# or OE# high during toggle bit polling	Min	0				ns	
t <sub>DVWH</sub>	t <sub>DS</sub>	Data Setup Time	Min	45				ns	
t <sub>WHDX</sub>	t <sub>DH</sub>	Data Hold Time	Min	0				ns	
	t <sub>OEPH</sub>	Output Enable High during toggle bit polling	Min	20				ns	
t <sub>GHWL</sub>	t <sub>GHWL</sub>	Read Recovery Time Before Write (OE# High to WE# Low)	Min	0				ns	
t <sub>ELWL</sub>	t <sub>CS</sub>	CE# Setup Time	Min	0				ns	
t <sub>WHEH</sub>	t <sub>CH</sub>	CE# Hold Time	Min	0				ns	
t <sub>WLWH</sub>	t <sub>WP</sub>	Write Pulse Width	Min	35				ns	
t <sub>WHDL</sub>	t <sub>WPH</sub>	Write Pulse Width High	Min	30				ns	
t <sub>WHWH1</sub>	t <sub>WHWH1</sub>	Write Buffer Program Operation (Notes 2, 3)		Typ	TBD				µs
		Effective Write Buffer Program Operation (Notes 2, 4)	Per Word	Typ	TBD				µs
		Accelerated Effective Write Buffer Program Operation (Notes 2, 4)	Per Word	Typ	TBD				µs
		Program Operation (Note 2)	Word	Typ	TBD				µs
		Accelerated Programming Operation (Note 2)	Word	Typ	TBD				µs
t <sub>WHWH2</sub>	t <sub>WHWH2</sub>	Sector Erase Operation (Note 2)		Typ	TBD				sec
	t <sub>VHH</sub>	V <sub>HH</sub> Rise and Fall Time (Note 1)		Min	250				ns
	t <sub>VCS</sub>	V <sub>CC</sub> Setup Time (Note 1)		Min	50				µs

**Notes:**

1. Not 100% tested.
2. See the "AC Characteristics" section for more information.
3. For 1-16 words/1-32 bytes programmed.
4. Effective write buffer specification is based upon a 16-word/32-byte write buffer operation.
5. Unless otherwise indicated, AC specifications for 80 ns and 90 ns speed options are tested with V<sub>I0</sub> = V<sub>CC</sub> = 3 V. AC specifications for 90 ns and 100 ns speed options are tested with V<sub>I0</sub> = 1.8 V and V<sub>CC</sub> = 3.0 V.

## AC Characteristics

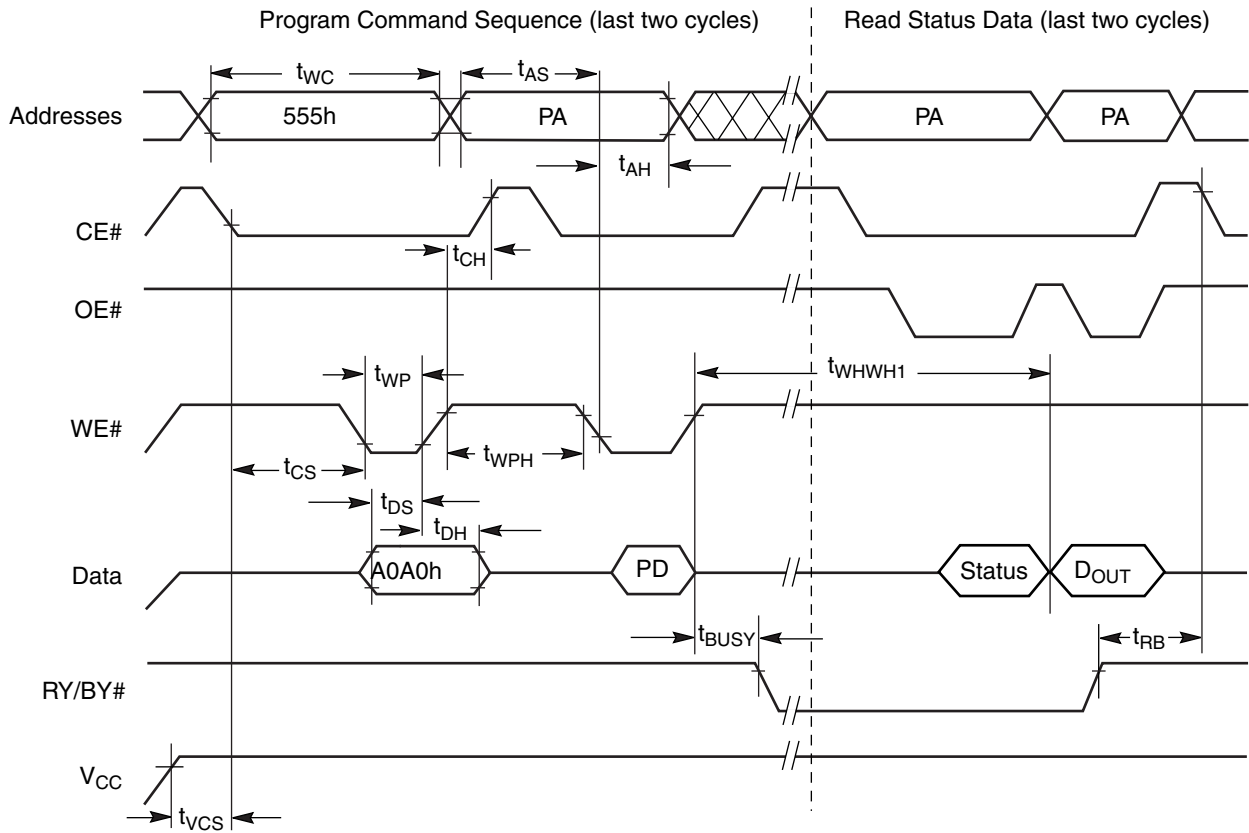

**Notes:**

1. PA = program address, PD = program data, D<sub>OUT</sub> is the true data at the program address.
2. Illustration shows device in word mode.

**Figure 14. Program Operation Timings**

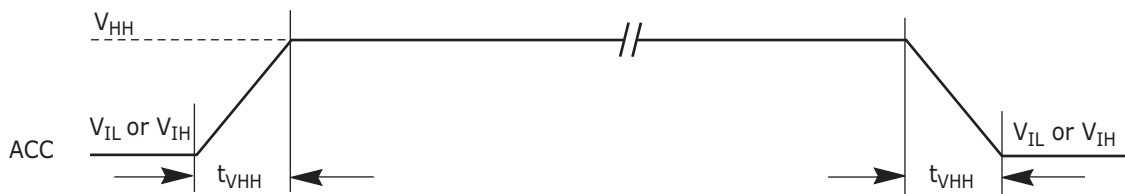

**Figure 15. Accelerated Program Timing Diagram**

**Notes:**

1. Not 100% tested.
2. CE#, OE# = V<sub>IL</sub>
3. OE# = V<sub>IL</sub>
4. See Figure 9 and Table 13 for test specifications.



## AC Characteristics

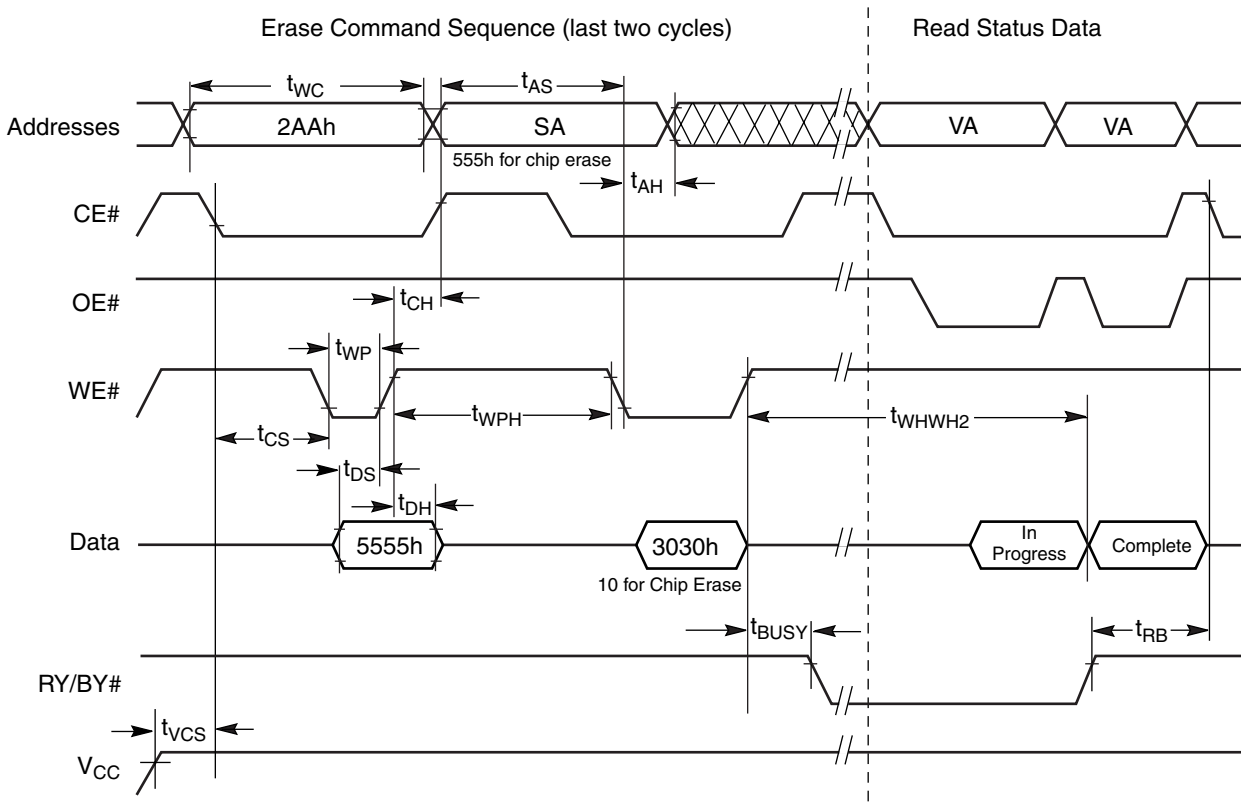

**Notes:**

1. SA = sector address (for Sector Erase), VA = Valid Address for reading status data (see "Write Operation Status").
2. These waveforms are for the word mode.

**Figure 16. Chip/Sector Erase Operation Timings**

## AC Characteristics

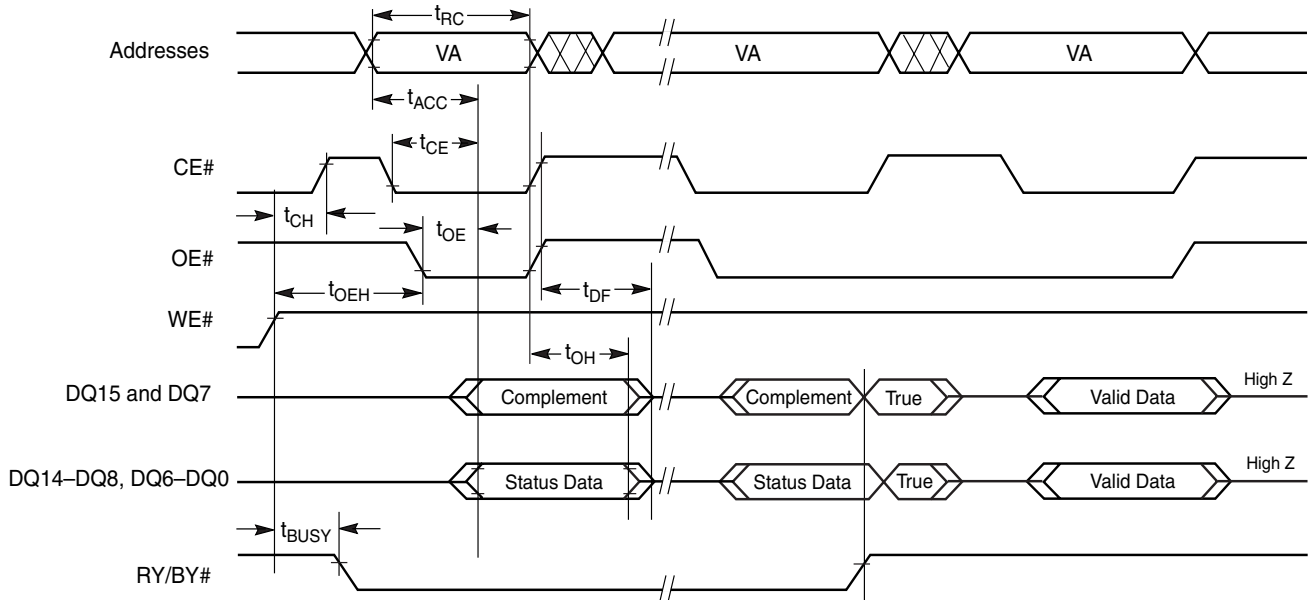

**Note:** VA = Valid address. Illustration shows first status cycle after command sequence, last status read cycle, and array data read cycle.

**Figure 17. Data# Polling Timings (During Embedded Algorithms)**

## AC Characteristics

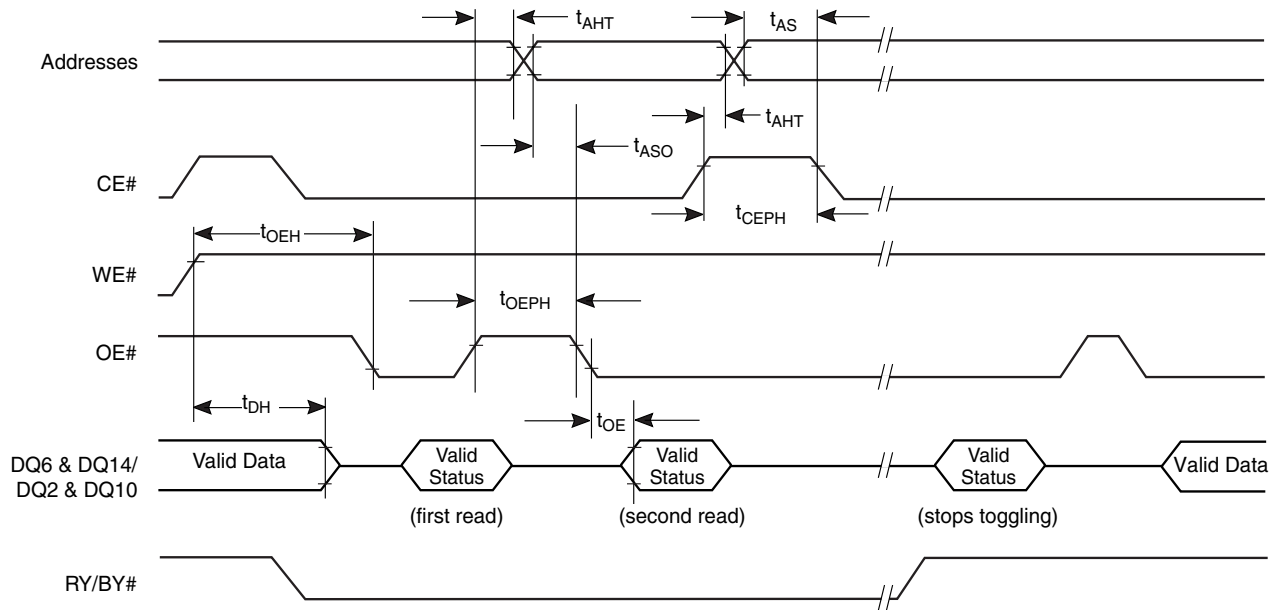

**Note:** VA = Valid address; not required for DQ6. Illustration shows first two status cycle after command sequence, last status read cycle, and array data read cycle

**Figure 18. Toggle Bit Timings (During Embedded Algorithms)**

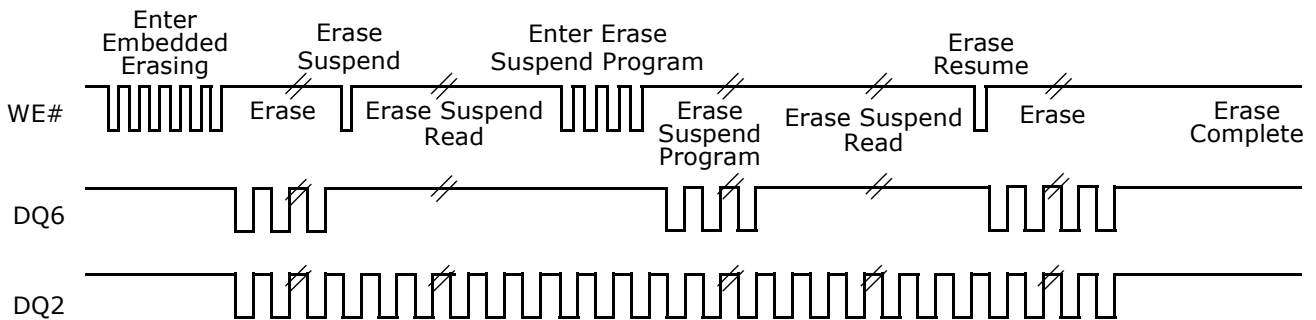

**Note:** DQ2 toggles only when read at an address within an erase-suspended sector. The system may use OE# or CE# to toggle DQ2 and DQ6.

**Figure 19. DQ2 vs. DQ6**

## AC Characteristics

### Alternate CE# Controlled Erase and Program Operations—S29GL512N Only

Parameter		Description		Speed Options				Unit	
JEDEC	Std.			90	100	100	110		
t <sub>AVAV</sub>	t <sub>WC</sub>	Write Cycle Time (Note 1)	Min	90	100	100	110	ns	
t <sub>AVWL</sub>	t <sub>AS</sub>	Address Setup Time	Min	0				ns	
t <sub>ELAX</sub>	t <sub>AH</sub>	Address Hold Time	Min	45				ns	
t <sub>DVEH</sub>	t <sub>DS</sub>	Data Setup Time	Min	45				ns	
t <sub>EHDX</sub>	t <sub>DH</sub>	Data Hold Time	Min	0				ns	
t <sub>GHEL</sub>	t <sub>GHEL</sub>	Read Recovery Time Before Write (OE# High to WE# Low)	Min	0				ns	
t <sub>WLEL</sub>	t <sub>WS</sub>	WE# Setup Time	Min	0				ns	
t <sub>EHWL</sub>	t <sub>WH</sub>	WE# Hold Time	Min	0				ns	
t <sub>ELEH</sub>	t <sub>CP</sub>	CE# Pulse Width	Min	45				ns	
t <sub>EHEL</sub>	t <sub>CPH</sub>	CE# Pulse Width High	Min	30				ns	
t <sub>WHWH1</sub>	t <sub>WHWH1</sub>	Write Buffer Program Operation (Notes 2, 3)	Typ	TBD				μs	
		Effective Write Buffer Program Operation (Notes 2, 4)	Per Word	Typ	TBD				μs
		Effective Accelerated Write Buffer Program Operation (Notes 2, 4)	Per Word	Typ	TBD				μs
		Program Operation (Note 2)	Word	Typ	TBD				μs
		Accelerated Programming Operation (Note 2)	Word	Typ	TBD				μs
t <sub>WHWH2</sub>	t <sub>WHWH2</sub>	Sector Erase Operation (Note 2)	Typ	TBD				sec	

**Notes:**

1. Not 100% tested.
2. See the "AC Characteristics" section for more information.
3. For 1–16 words/1–32 bytes programmed.
4. Effective write buffer specification is based upon a 16-word/32-byte write buffer operation.
5. Unless otherwise indicated, AC specifications for 90 ns and 100 ns speed options are tested with  $V_{IO} = V_{CC} = 3 V$ . AC specifications for 100 ns and 110 ns speed options are tested with  $V_{IO} = 1.8 V$  and  $V_{CC} = 3.0 V$ .

## AC Characteristics

### Alternate CE# Controlled Erase and Program Operations—S29GL256N Only

Parameter		Description		Speed Options				Unit	
JEDEC	Std.			80	90	90	100		
t <sub>AVAV</sub>	t <sub>WC</sub>	Write Cycle Time (Note 1)	Min	80	90	90	100	ns	
t <sub>AVWL</sub>	t <sub>AS</sub>	Address Setup Time	Min	0				ns	
t <sub>ELAX</sub>	t <sub>AH</sub>	Address Hold Time	Min	45				ns	
t <sub>DVEH</sub>	t <sub>DS</sub>	Data Setup Time	Min	45				ns	
t <sub>EHDx</sub>	t <sub>DH</sub>	Data Hold Time	Min	0				ns	
t <sub>GHEL</sub>	t <sub>GHEL</sub>	Read Recovery Time Before Write (OE# High to WE# Low)	Min	0				ns	
t <sub>WLEL</sub>	t <sub>WS</sub>	WE# Setup Time	Min	0				ns	
t <sub>EHWL</sub>	t <sub>WH</sub>	WE# Hold Time	Min	0				ns	
t <sub>ELEH</sub>	t <sub>CP</sub>	CE# Pulse Width	Min	45				ns	
t <sub>EHEL</sub>	t <sub>CPH</sub>	CE# Pulse Width High	Min	30				ns	
t <sub>WHWH1</sub>	t <sub>WHWH1</sub>	Write Buffer Program Operation (Notes 2, 3)	Typ	TBD				μs	
		Effective Write Buffer Program Operation (Notes 2, 4)	Per Word	Typ	TBD				μs
		Effective Accelerated Write Buffer Program Operation (Notes 2, 4)	Per Word	Typ	TBD				μs
		Program Operation (Note 2)	Word	Typ	TBD				μs
		Accelerated Programming Operation (Note 2)	Word	Typ	TBD				μs
t <sub>WHWH2</sub>	t <sub>WHWH2</sub>	Sector Erase Operation (Note 2)	Typ	TBD				sec	

**Notes:**

1. Not 100% tested.
2. See the "AC Characteristics" section for more information.
3. For 1–16 words/1–32 bytes programmed.
4. Effective write buffer specification is based upon a 16-word/32-byte write buffer operation.
5. Unless otherwise indicated, AC specifications for 80 ns and 90 ns speed options are tested with V<sub>IO</sub> = V<sub>CC</sub> = 3 V. AC specifications for 90 ns and 100 ns speed options are tested with V<sub>IO</sub> = 1.8 V and V<sub>CC</sub> = 3.0 V.

## AC Characteristics

### Alternate CE# Controlled Erase and Program Operations—S29GLI28N Only

Parameter		Description		Speed Options				Unit	
JEDEC	Std.			80	90	90	100		
t <sub>AVAV</sub>	t <sub>WC</sub>	Write Cycle Time (Note 1)	Min	80	90	90	100	ns	
t <sub>AVWL</sub>	t <sub>AS</sub>	Address Setup Time	Min	0				ns	
t <sub>ELAX</sub>	t <sub>AH</sub>	Address Hold Time	Min	45				ns	
t <sub>DVEH</sub>	t <sub>DS</sub>	Data Setup Time	Min	45				ns	
t <sub>EHDX</sub>	t <sub>DH</sub>	Data Hold Time	Min	0				ns	
t <sub>GHEL</sub>	t <sub>GHEL</sub>	Read Recovery Time Before Write (OE# High to WE# Low)	Min	0				ns	
t <sub>WLEL</sub>	t <sub>WS</sub>	WE# Setup Time	Min	0				ns	
t <sub>EHWL</sub>	t <sub>WH</sub>	WE# Hold Time	Min	0				ns	
t <sub>ELEH</sub>	t <sub>CP</sub>	CE# Pulse Width	Min	45				ns	
t <sub>EHEL</sub>	t <sub>CPH</sub>	CE# Pulse Width High	Min	30				ns	
t <sub>WHWH1</sub>	t <sub>WHWH1</sub>	Write Buffer Program Operation (Notes 2, 3)	Typ	TBD				μs	
		Effective Write Buffer Program Operation (Notes 2, 4)	Per Word	Typ	TBD				μs
		Effective Accelerated Write Buffer Program Operation (Notes 2, 4)	Per Word	Typ	TBD				μs
		Program Operation (Note 2)	Word	Typ	TBD				μs
		Accelerated Programming Operation (Note 2)	Word	Typ	TBD				μs
t <sub>WHWH2</sub>	t <sub>WHWH2</sub>	Sector Erase Operation (Note 2)	Typ	TBD				sec	

**Notes:**

1. Not 100% tested.
2. See the "AC Characteristics" section for more information.
3. For 1–16 words/1–32 bytes programmed.
4. Effective write buffer specification is based upon a 16-word/32-byte write buffer operation.
5. Unless otherwise indicated, AC specifications for 80 ns and 90 ns speed options are tested with  $V_{IO} = V_{CC} = 3 V$ . AC specifications for 90 ns and 100 ns speed options are tested with  $V_{IO} = 1.8 V$  and  $V_{CC} = 3.0 V$ .

## AC Characteristics

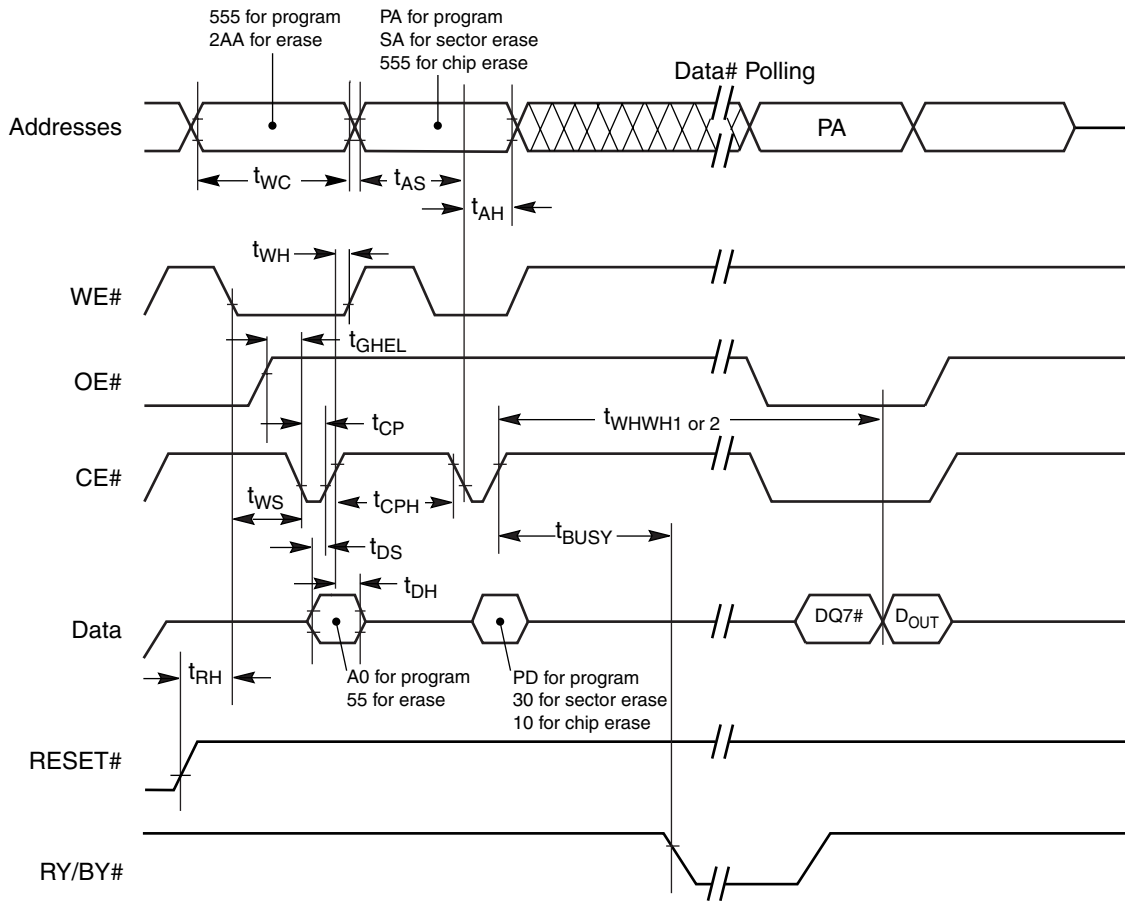

**Notes:**

1. Figure indicates last two bus cycles of a program or erase operation.
2. PA = program address, SA = sector address, PD = program data.
3. DQ7# is the complement of the data written to the device. D<sub>OUT</sub> is the data written to the device.
4. Waveforms are for the word mode.

**Figure 20. Alternate CE# Controlled Write (Erase/Program) Operation Timings**

## Latchup Characteristics

Description	Min	Max
Input voltage with respect to V <sub>SS</sub> on all pins except I/O pins (including A9, OE#, and RESET#)	-1.0 V	12.5 V
Input voltage with respect to V <sub>SS</sub> on all I/O pins	-1.0 V	V <sub>CC</sub> + 1.0 V
V <sub>CC</sub> Current	-100 mA	+100 mA

**Note:** Includes all pins except V<sub>CC</sub>. Test conditions: V<sub>CC</sub> = 3.0 V, one pin at a time.

## Erase And Programming Performance

Parameter		Typ (Note 1)	Max (Note 2)	Unit	Comments
Sector Erase Time		TBD	TBD	sec	Excludes 00h programming prior to erasure (Note 5)
Chip Erase Time	S29GL128N	TBD	TBD	sec	
	S29GL256N	TBD	TBD		
	S29GL512N	TBD	TBD		
Total Write Buffer Time (Note 3)		TBD	TBD	μs	Excludes system level overhead (Note 6)
Total Accelerated Effective Write Buffer Programming Time (Note 3)		TBD	TBD	μs	
Chip Program Time	S29GL128N	TBD	TBD	sec	
	S29GL256N	TBD	TBD		
	S29GL512N	TBD	TBD		

**Notes:**

1. Typical program and erase times assume the following conditions: 10,000 cycles, 25°C, 3.0 V  $V_{CC}$  checkerboard pattern.
2. Under worst case conditions of 100,000 cycles, 90°C,  $V_{CC} = 3.0$  V.
3. Effective write buffer specification is based upon a 16-word write buffer operation.
4. The typical chip programming time is considerably less than the maximum chip programming time listed, since most words program faster than the maximum program times listed.
5. In the pre-programming step of the Embedded Erase algorithm, all bits are programmed to 00h before erasure.
6. System-level overhead is the time required to execute the two- or four-bus-cycle sequence for the program command. See Table 17 for further information on command definitions.

## TSOP Pin and BGA Package Capacitance

Parameter Symbol	Parameter Description	Test Setup		Typ	Max	Unit
$C_{IN}$	Input Capacitance	$V_{IN} = 0$	TSOP	6	7.5	pF
$C_{OUT}$	Output Capacitance	$V_{OUT} = 0$	TSOP	8.5	12	pF
$C_{IN2}$	Control Pin Capacitance	$V_{IN} = 0$	TSOP	7.5	9	pF

**Notes:**

1. Sampled, not 100% tested.
2. Test conditions  $T_A = 25^\circ\text{C}$ ,  $f = 1.0$  MHz.



# pSRAM Type I

4Mbit (256K Word x 16-bit)

8Mbit (512K Word x 16-bit)

16Mbit (1M Word x 16-bit)

32Mbit (2M Word x 16-bit)

64Mbit (4M Word x 16-bit)

## Functional Description

Mode	CE#	CE2/ZZ#	OE#	WE#	UB#	LB#	Addresses	I/O 1-8	I/O 9-16	Power
Read (word)	L	H	L	H	L	L	X	Dout	Dout	I <sub>ACTIVE</sub>
Read (lower byte)	L	H	L	H	H	L	X	Dout	High-Z	I <sub>ACTIVE</sub>
Read (upper byte)	L	H	L	H	L	H	X	High-Z	Dout	I <sub>ACTIVE</sub>
Write (word)	L	H	X	L	L	L	X	Din	Din	I <sub>ACTIVE</sub>
Write (lower byte)	L	H	X	L	H	L	X	Din	Invalid	I <sub>ACTIVE</sub>
Write (upper byte)	L	H	X	L	L	H	X	Invalid	Din	I <sub>ACTIVE</sub>
Outputs disabled	L	H	H	H	X	X	X	High-Z	High-Z	I <sub>ACTIVE</sub>
Standby	H	H	X	X	X	X	X	High-Z	High-Z	I <sub>STANDBY</sub>
Deep power down	H	L	X	X	X	X	X	High-Z	High-Z	I <sub>DEEP SLEEP</sub>

## Absolute Maximum Ratings

Item	Symbol	Ratings	Units
Voltage on any pin relative to V <sub>SS</sub>	V <sub>in</sub> , V <sub>out</sub>	-0.2 to V <sub>CC</sub> + 0.3	V
Voltage on V <sub>CC</sub> relative to V <sub>SS</sub>	V <sub>CC</sub>	-0.2 to 3.6	V
Power dissipation	P <sub>D</sub>	1	W
Storage temperature	T <sub>STG</sub>	-55 to 150	°C
Operating temperature	T <sub>A</sub>	-25 to 85	°C

## DC Characteristics (4Mb pSRAM Asynchronous)

Performance Grade			Asynchronous		
Density			-70		
Density			4Mb pSRAM		
Symbol	Parameter	Conditions	Min	Max	Units
V <sub>CC</sub>	Power Supply		2.7	3.3	V
V <sub>IH</sub>	Input High Level		0.8 V <sub>CCq</sub>	V <sub>CC</sub> + 0.3	V
V <sub>IL</sub>	Input Low Level		-0.3	0.4	V
I <sub>IL</sub>	Input Leakage Current	V <sub>in</sub> = 0 to V <sub>CC</sub>		0.5	μA
I <sub>LO</sub>	Output Leakage Current	OE = V <sub>IH</sub> or Chip Disabled		0.5	μA
V <sub>OH</sub>	Output High Voltage	I <sub>OH</sub> = -1.0 mA			V
		I <sub>OH</sub> = -0.2 mA	0.8 V <sub>CCq</sub>		
		I <sub>OH</sub> = -0.5 mA			
V <sub>OL</sub>	Output Low Voltage	I <sub>OL</sub> = 2.0 mA			V
		I <sub>OL</sub> = 0.2 mA		0.2	
		I <sub>OL</sub> = 0.5 mA			
I <sub>ACTIVE</sub>	Operating Current	V <sub>CC</sub> = 3.3 V		25	mA
I <sub>STANDBY</sub>	Standby Current	V <sub>CC</sub> = 3.0 V		70	μA
		V <sub>CC</sub> = 3.3 V			
I <sub>DEEP SLEEP</sub>	Deep Power Down Current			x	μA
I <sub>PAR 1/4</sub>	1/4 Array PAR Current			x	μA
I <sub>PAR 1/2</sub>	1/2 Array PAR Current			x	μA

## DC Characteristics (8Mb pSRAM Asynchronous)

			Asynchronous								
Version			B						C		
Performance Grade			-55			-70			-70		
Density			8Mb pSRAM			8Mb pSRAM			8Mb pSRAM		
Symbol	Parameter	Conditions	Min	Max	Units	Min	Max	Units	Min	Max	Units
V <sub>CC</sub>	Power Supply		2.7	3.3	V	2.7	3.6	V	2.7	3.3	V
V <sub>IH</sub>	Input High Level		2.2	V <sub>CC</sub> + 0.3	V	2.2	V <sub>CC</sub> + 0.3	V	0.8	V <sub>CC</sub> +0.3	V
V <sub>IL</sub>	Input Low Level		-0.3	0.6	V	-0.3	0.6	V	-0.3	0.4	V
I <sub>IL</sub>	Input Leakage Current	V <sub>in</sub> = 0 to V <sub>CC</sub>		0.5	μA		0.5	μA		0.5	μA
I <sub>LO</sub>	Output Leakage Current	OE = V <sub>IH</sub> or Chip Disabled		0.5	μA		0.5	μA		0.5	μA
V <sub>OH</sub>	Output High Voltage	I <sub>OH</sub> = -1.0 mA	V <sub>CC</sub> -0.4		V	V <sub>CC</sub> -0.4		V			V
		I <sub>OH</sub> = -0.2 mA					0.8 V <sub>CCQ</sub>				
		I <sub>OH</sub> = -0.5 mA									
V <sub>OL</sub>	Output Low Voltage	I <sub>OL</sub> = 2.0 mA		0.4	V		0.4	V			V
		I <sub>OL</sub> = 0.2 mA							0.2		
		I <sub>OL</sub> = 0.5 mA									
I <sub>ACTIVE</sub>	Operating Current	V <sub>CC</sub> = 3.3 V		25	mA		23	mA		25	mA
I <sub>STANDBY</sub>	Standby Current	V <sub>CC</sub> = 3.0 V		60	μA		60	μA		70	μA
		V <sub>CC</sub> = 3.3 V									
I <sub>DEEP SLEEP</sub>	Deep Power Down Current			x	μA		x	μA		x	μA
I <sub>PAR 1/4</sub>	1/4 Array PAR Current			x	μA		x	μA		x	μA
I <sub>PAR 1/2</sub>	1/2 Array PAR Current			x	μA		x	μA		x	μA

## DC Characteristics (16Mb pSRAM Asynchronous)

Performance Grade			Asynchronous					
			-55			-70		
Density			16Mb pSRAM			16Mb pSRAM		
Symbol	Parameter	Conditions	Minimum	Maximum	Units	Minimum	Maximum	Units
V <sub>CC</sub>	Power Supply		2.7	3.6	V	2.7	3.6	V
V <sub>IH</sub>	Input High Level		2.2	V <sub>CC</sub> + 0.3	V	2.2	V <sub>CC</sub> + 0.3	V
V <sub>IL</sub>	Input Low Level		-0.3	0.6	V	-0.3	0.6	V
I <sub>IL</sub>	Input Leakage Current	V <sub>in</sub> = 0 to V <sub>CC</sub>		0.5	μA		0.5	μA
I <sub>LO</sub>	Output Leakage Current	OE = V <sub>IH</sub> or Chip Disabled		0.5	μA		0.5	μA
V <sub>OH</sub>	Output High Voltage	I <sub>OH</sub> = -1.0 mA	V <sub>CC</sub> -0.4		V	V <sub>CC</sub> -0.4		V
		I <sub>OH</sub> = -0.2 mA						
		I <sub>OH</sub> = -0.5 mA						
V <sub>OL</sub>	Output Low Voltage	I <sub>OL</sub> = 2.0 mA		0.4	V		0.4	V
		I <sub>OL</sub> = 0.2 mA						
		I <sub>OL</sub> = 0.5 mA						
I <sub>ACTIVE</sub>	Operating Current	V <sub>CC</sub> = 3.3 V		25	mA		25	mA
I <sub>STANDBY</sub>	Standby Current	V <sub>CC</sub> = 3.0 V		100	μA		100	μA
		V <sub>CC</sub> = 3.3 V						
I <sub>DEEP SLEEP</sub>	Deep Power Down Current			x	μA		x	μA
I <sub>PAR 1/4</sub>	1/4 Array PAR Current			x	μA		x	μA
I <sub>PAR 1/2</sub>	1/2 Array PAR Current			x	μA		x	μA

## DC Characteristics (16Mb pSRAM Page Mode)

Performance Grade			Page Mode								
			-60			-65			-70		
Density			16Mb pSRAM			16Mb pSRAM			16Mb pSRAM		
Symbol	Parameter	Conditions	Min	Max	Units	Min	Max	Units	Min	Max	Units
V <sub>CC</sub>	Power Supply		2.7	3.3	V	2.7	3.3	V	2.7	3.3	V
V <sub>IH</sub>	Input High Level		0.8 V <sub>CCq</sub>	V <sub>CC</sub> + 0.2	V	0.8 V <sub>CCq</sub>	V <sub>CC</sub> + 0.2	V	0.8 V <sub>CCq</sub>	V <sub>CC</sub> + 0.2	V
V <sub>IL</sub>	Input Low Level		-0.2	0.2 V <sub>CCq</sub>	V	-0.2	0.2 V <sub>CCq</sub>	V	-0.2	0.2 V <sub>CCq</sub>	V
I <sub>IL</sub>	Input Leakage Current	V <sub>in</sub> = 0 to V <sub>CC</sub>		1	μA		1	μA		1	μA
I <sub>LO</sub>	Output Leakage Current	OE = V <sub>IH</sub> or Chip Disabled		1	μA		1	μA		1	μA
V <sub>OH</sub>	Output High Voltage	I <sub>OH</sub> = -1.0 mA			V			V			V
		I <sub>OH</sub> = -0.2 mA									
		I <sub>OH</sub> = -0.5 mA	0.8 V <sub>CCq</sub>			0.8 V <sub>CCq</sub>			0.8 V <sub>CCq</sub>		
V <sub>OL</sub>	Output Low Voltage	I <sub>OL</sub> = 2.0 mA			V			V			V
		I <sub>OL</sub> = 0.2 mA									
		I <sub>OL</sub> = 0.5 mA		0.2 V <sub>CCq</sub>			0.2 V <sub>CCq</sub>			0.2 V <sub>CCq</sub>	
I <sub>ACTIVE</sub>	Operating Current	V <sub>CC</sub> = 3.3 V		25	mA		25	mA		25	mA
I <sub>STANDBY</sub>	Standby Current	V <sub>CC</sub> = 3.0 V			μA			μA			μA
		V <sub>CC</sub> = 3.3 V		100			100			100	
I <sub>DEEP SLEEP</sub>	Deep Power Down Current			10	μA		10	μA		10	μA
I <sub>PAR 1/4</sub>	1/4 Array PAR Current			65	μA		65	μA		65	μA
I <sub>PAR 1/2</sub>	1/2 Array PAR Current			80	μA		80	μA		80	μA

## DC Characteristics (32Mb pSRAM Page Mode)

			Page Mode											
Version			C			E								
Performance Grade			-65			-60			-65			-70		
Density			32Mb pSRAM			32Mb pSRAM			32Mb pSRAM			32Mb pSRAM		
Symbol	Parameter	Conditions	Min	Max	Units	Min	Max	Units	Min	Max	Units	Min	Max	Units
V <sub>CC</sub>	Power Supply		2.7	3.6	V	2.7	3.3	V	2.7	3.3	V	2.7	3.3	V
V <sub>IH</sub>	Input High Level		1.4	V <sub>CC</sub> + 0.2	V	0.8 V <sub>CCq</sub>	V <sub>CC</sub> + 0.2	V	0.8 V <sub>CCq</sub>	V <sub>CC</sub> + 0.2	V	0.8 V <sub>CCq</sub>	V <sub>CC</sub> + 0.2	V
V <sub>IL</sub>	Input Low Level		-0.2	0.4	V	-0.2	0.2 V <sub>CCq</sub>	V	-0.2	0.2 V <sub>CCq</sub>	V	-0.2	0.2 V <sub>CCq</sub>	V
I <sub>IL</sub>	Input Leakage Current	V <sub>in</sub> = 0 to V <sub>CC</sub>		0.5	μA		1	μA		1	μA		1	μA
I <sub>LO</sub>	Output Leakage Current	OE = V <sub>IH</sub> or Chip Disabled		0.5	μA		1	μA		1	μA		1	μA
V <sub>OH</sub>	Output High Voltage	I <sub>OH</sub> = -1.0 mA			V			V			V			V
		I <sub>OH</sub> = -0.2 mA	0.8 V <sub>CCq</sub>											
		I <sub>OH</sub> = -0.5 mA		0.8 V <sub>CCq</sub>			0.8 V <sub>CCq</sub>			0.8 V <sub>CCq</sub>				
V <sub>OL</sub>	Output Low Voltage	I <sub>OL</sub> = 2.0 mA			V			V			V			V
		I <sub>OL</sub> = 0.2 mA		0.2										
		I <sub>OL</sub> = 0.5 mA				0.2 V <sub>CCq</sub>			0.2 V <sub>CCq</sub>			0.2 V <sub>CCq</sub>		
I <sub>ACTIVE</sub>	Operating Current	V <sub>CC</sub> = 3.3 V		25	mA		25	mA		25	mA		25	mA
I <sub>STANDBY</sub>	Standby Current	V <sub>CC</sub> = 3.0 V			μA			μA			μA			μA
		V <sub>CC</sub> = 3.3 V		100			120			120			120	
I <sub>DEEP SLEEP</sub>	Deep Power Down Current			10	μA		10	μA		10	μA		10	μA
I <sub>PAR 1/4</sub>	1/4 Array PAR Current			65	μA		75	μA		75	μA		75	μA
I <sub>PAR 1/2</sub>	1/2 Array PAR Current			80	μA		90	μA		90	μA		90	μA

## DC Characteristics (64Mb pSRAM Page Mode)

Performance Grade			Page Mode		
Density			-70		
Density			64Mb pSRAM		
Symbol	Parameter	Conditions	Min	Max	Units
$V_{CC}$	Power Supply		2.7	3.3	V
$V_{IH}$	Input High Level		$0.8 V_{CCq}$	$V_{CC} + 0.2$	V
$V_{IL}$	Input Low Level		-0.2	$0.2 V_{CCq}$	V
$I_{IL}$	Input Leakage Current	$V_{in} = 0 \text{ to } V_{CC}$		1	$\mu\text{A}$
$I_{LO}$	Output Leakage Current	OE = $V_{IH}$ or Chip Disabled		1	$\mu\text{A}$
$V_{OH}$	Output High Voltage	$I_{OH} = -1.0 \text{ mA}$			V
		$I_{OH} = -0.2 \text{ mA}$			
		$I_{OH} = -0.5 \text{ mA}$	$0.8 V_{CCq}$		
$V_{OL}$	Output Low Voltage	$I_{OL} = 2.0 \text{ mA}$			V
		$I_{OL} = 0.2 \text{ mA}$			
		$I_{OL} = 0.5 \text{ mA}$		$0.2 V_{CCq}$	
$I_{ACTIVE}$	Operating Current	$V_{CC} = 3.3 \text{ V}$		25	mA
$I_{STANDBY}$	Standby Current	$V_{CC} = 3.0 \text{ V}$			$\mu\text{A}$
		$V_{CC} = 3.3 \text{ V}$		120	
$I_{DEEP SLEEP}$	Deep Power Down Current			10	$\mu\text{A}$
$I_{PAR 1/4}$	1/4 Array PAR Current			65	$\mu\text{A}$
$I_{PAR 1/2}$	1/2 Array PAR Current			80	$\mu\text{A}$

## Timing Test Conditions

Item	
Input Pulse Level	$0.1 V_{CC}$ to $0.9 V_{CC}$
Input Rise and Fall Time	5ns
Input and Output Timing Reference Levels	$0.5 V_{CC}$
Operating Temperature	$-25^{\circ}\text{C}$ to $+85^{\circ}\text{C}$

## Output Load Circuit

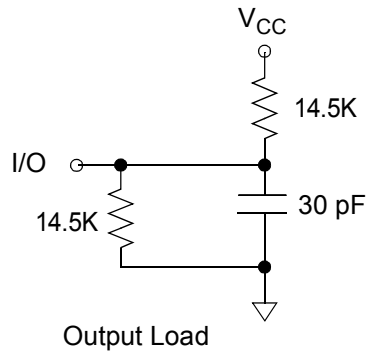

Figure 2I. Output Load Circuit

## Power Up Sequence

After applying power, maintain a stable power supply for a minimum of 200  $\mu$ s after  $CE\# > V_{IH}$ .



## AC Characteristics

### (4Mb pSRAM Page Mode)

			Asynchronous		
Performance Grade			-70		
Density			4Mb pSRAM		
3 Volt	Symbol	Parameter	Min	Max	Units
<b>Read</b>	trc	Read cycle time	70		ns
	taa	Address Access Time		70	ns
	tco	Chip select to output		70	ns
	toe	Output enable to valid output		20	ns
	tba	UB#, LB# Access time		70	ns
	tlz	Chip select to Low-z output	10		ns
	tblz	UB#, LB# Enable to Low-Z output	10		ns
	tolz	Output enable to Low-Z output	5		ns
	thz	Chip enable to High-Z output	0	20	ns
	tbhz	UB#, LB# disable to High-Z output	0	20	ns
	tohz	Output disable to High-Z output	0	20	ns
	toh	Output hold from Address Change	10		ns

Performance Grade			Asynchronous		
			-70		
Density			4Mb pSRAM		
3 Volt	Symbol	Parameter	Min	Max	Units
<b>Write</b>	twc	Write cycle time	70		ns
	tcw	Chipselect to end of write	70		ns
	tas	Address set up Time	0		ns
	taw	Address valid to end of write	70		ns
	tbw	UB#, LB# valid to end of write	70		ns
	twp	Write pulse width	55		ns
	twr	Write recovery time	0		ns
	twhz	Write to output High-Z		20	ns
	tdw	Data to write time overlap	25		ns
	tdh	Data hold from write time	0		ns
	tow	End write to output Low-Z	5		
	tow	Write high pulse width	7.5		ns
<b>Other</b>	tpc	Page read cycle	x		
	tpa	Page address access time		x	
	twpc	Page write cycle	x		
	tcp	Chip select high pulse width	x		

## AC Characteristics

### (8Mb pSRAM Asynchronous)

			Asynchronous								
Version			B						C		
Performance Grade			-55			-70			-70		
Density			8Mb pSRAM			8Mb pSRAM			8Mb pSRAM		
3 Volt	Symbol	Parameter	Min	Max	Units	Min	Max	Units	Min	Max	Units
Read	trc	Read cycle time	55		ns	70		ns	70		ns
	taa	Address Access Time		55	ns		70	ns		70	ns
	tco	Chip select to output		55	ns		70	ns		70	ns
	toe	Output enable to valid output		30	ns		35	ns		20	ns
	tba	UB#, LB# Access time		55	ns		70	ns		70	ns
	tlz	Chip select to Low-z output	5		ns	5		ns	10		ns
	tblz	UB#, LB# Enable to Low-Z output	5		ns	5		ns	10		ns
	tolz	Output enable to Low-Z output	5		ns	5		ns	5		ns
	thz	Chip enable to High-Z output	0	20	ns	0	25	ns	0	20	ns
	tbhz	UB#, LB# disable to High-Z output	0	20	ns	0	25	ns	0	20	ns
	tohz	Output disable to High-Z output	0	20	ns	0	25	ns	0	20	ns
	toh	Output hold from Address Change	10		ns	10		ns	10		ns

Version			Asynchronous								
			B						C		
Performance Grade			-55			-70			-70		
Density			8Mb pSRAM			8Mb pSRAM			8Mb pSRAM		
3 Volt	Symbol	Parameter	Min	Max	Units	Min	Max	Units	Min	Max	Units
<b>Write</b>	twc	Write cycle time	55		ns	70		ns	70		ns
	tcw	Chip select to end of write	45		ns	55		ns	70		ns
	tas	Address set up Time	0		ns	0		ns	0		ns
	taw	Address valid to end of write	45		ns	55		ns	70		ns
	tbw	UB#, LB# valid to end of write	45		ns	55		ns	70		ns
	twp	Write pulse width	45		ns	55		ns	55		ns
	twr	Write recovery time	0		ns	0		ns	0		ns
	twhz	Write to output High-Z		25	ns		25			20	ns
	tdw	Data to write time overlap	40		ns	40		ns	25		ns
	tdh	Data hold from write time	0		ns	0		ns	0		ns
	tow	End write to output Low-Z	5			5			5		
	tow	Write high pulse width	x	x	ns	x	x	ns	x	x	ns
<b>Other</b>	tpc	Page read cycle	x			x			x		
	tpa	Page address access time		x			x			x	
	twpc	Page write cycle	x			x			x		
	tcp	Chip select high pulse width	x			x			x		

## AC Characteristics

### (16Mb pSRAM Asynchronous)

Performance Grade			Asynchronous					
			-55			-70		
Density			16Mb pSRAM			16Mb pSRAM		
3 Volt	Symbol	Parameter	Min	Max	Units	Min	Max	Units
<b>Read</b>	trc	Read cycle time	55		ns	70		ns
	taa	Address Access Time		55	ns		70	ns
	tco	Chip select to output		55	ns		70	ns
	toe	Output enable to valid output		30	ns		35	ns
	tba	UB#, LB# Access time		55	ns		70	ns
	tlz	Chip select to Low-z output	5		ns	5		ns
	tblz	UB#, LB# Enable to Low-Z output	5		ns	5		ns
	tolz	Output enable to Low-Z output	5		ns	5		ns
	thz	Chip enable to High-Z output	0	25	ns	0	25	ns
	tbhz	UB#, LB# disable to High-Z output	0	25	ns	0	25	ns
	tohz	Output disable to High-Z output	0	25	ns	0	25	ns
	toh	Output hold from Address Change	10		ns	10		ns

Performance Grade			Asynchronous					
			-55			-70		
Density			16Mb pSRAM			16Mb pSRAM		
3 Volt	Symbol	Parameter	Min	Max	Units	Min	Max	Units
<b>Write</b>	twc	Write cycle time	55		ns	70		ns
	tcw	Chipselect to end of write	50		ns	55		ns
	tas	Address set up Time	0		ns	0		ns
	taw	Address valid to end of write	50		ns	55		ns
	tbw	UB#, LB# valid to end of write	50		ns	55		ns
	twp	Write pulse width	50		ns	55		ns
	twr	Write recovery time	0		ns	0		ns
	twhz	Write to output High-Z		25	ns		25	ns
	tdw	Data to write time overlap	25		ns	25		ns
	tdh	Data hold from write time	0		ns	0		ns
	tow	End write to output Low-Z	5			5		
	tow	Write high pulse width	x	x	ns	x	x	ns
<b>Other</b>	tpc	Page read cycle	x			x		
	tpa	Page address access time		x			x	
	twpc	Page write cycle	x			x		
	tcp	Chip select high pulse width	x			x		

## AC Characteristics

### (16Mb pSRAM Page Mode)

Performance Grade			Page Mode								
			-60			-65			-70		
Density			16Mb pSRAM			16Mb pSRAM			16Mb pSRAM		
3 Volt	Symbol	Parameter	Min	Max	Units	Min	Max	Units	Min	Max	Units
<b>Read</b>	trc	Read cycle time	60	20k	ns	65	20k	ns	70	20k	ns
	taa	Address Access Time		60	ns		65	ns		70	ns
	tco	Chip select to output		60	ns		65	ns		70	ns
	toe	Output enable to valid output		25	ns		25	ns		25	ns
	tba	UB#, LB# Access time		60	ns		65	ns		70	ns
	tlz	Chip select to Low-z output	10		ns	10		ns	10		ns
	tblz	UB#, LB# Enable to Low-Z output	10		ns	10		ns	10		ns
	tolz	Output enable to Low-Z output	5		ns	5		ns	5		ns
	thz	Chip enable to High-Z output	0	5	ns	0	5	ns	0	5	ns
	tbhz	UB#, LB# disable to High-Z output	0	5	ns	0	5	ns	0	5	ns
	tohz	Output disable to High-Z output	0	5	ns	0	5	ns	0	5	ns
	toh	Output hold from Address Change	5		ns	5		ns	5		ns

Performance Grade			Page Mode								
			-60			-65			-70		
Density			16Mb pSRAM			16Mb pSRAM			16Mb pSRAM		
3 Volt	Symbol	Parameter	Min	Max	Units	Min	Max	Units	Min	Max	Units
<b>Write</b>	twc	Write cycle time	60	20k	ns	65	20k	ns	70	20k	ns
	tcw	Chipselect to end of write	50		ns	60		ns	60		ns
	tas	Address set up Time	0		ns	0		ns	0		ns
	taw	Address valid to end of write	50		ns	60		ns	60		ns
	tbw	UB#, LB# valid to end of write	50		ns	60		ns	60		ns
	twp	Write pulse width	50		ns	50		ns	50		ns
	twr	Write recovery time	0		ns	0		ns	0		ns
	twhz	Write to output High-Z		5	ns		5	ns		5	ns
	tdw	Data to write time overlap	20		ns	20		ns	20		ns
	tdh	Data hold from write time	0		ns	0		ns	0		ns
	tow	End write to output Low-Z	5			5			5		
	tow	Write high pulse width	7.5		ns	7.5		ns	7.5		ns
<b>Other</b>	tpc	Page read cycle	25	20k	ns	25	20k	ns	25	20k	ns
	tpa	Page address access time		25	ns		25	ns		25	ns
	twpc	Page write cycle	25	20k	ns	25	20k	ns	25	20k	ns
	tcp	Chip select high pulse width	10		ns	10		ns	10		ns



## AC Characteristics

### (32Mb pSRAM Page Mode)

			Page Mode											
Version			C			E								
Performance Grade			-65			-60			-65			-70		
Density			32Mb pSRAM			32Mb pSRAM			32Mb pSRAM			32Mb pSRAM		
3 Volt	Symbol	Parameter	Min	Max	Units	Min	Max	Units	Min	Max	Units	Min	Max	Units
Read	trc	Read cycle time	65	20k	ns	60	20k	ns	65	20k	ns	70	20k	ns
	taa	Address Access Time		65	ns		60	ns		65	ns		70	ns
	tco	Chip select to output		65	ns		60	ns		65	ns		70	ns
	toe	Output enable to valid output		20	ns		25	ns		25	ns		25	ns
	tba	UB#, LB# Access time		65	ns		60	ns		65	ns		70	ns
	tlz	Chip select to Low-z output	10		ns	10		ns	10		ns	10		ns
	tblz	UB#, LB# Enable to Low-Z output	10		ns	10		ns	10		ns	10		ns
	tolz	Output enable to Low-Z output	5		ns	5		ns	5		ns	5		ns
	thz	Chip enable to High-Z output	0	20	ns	0	5	ns	0	5	ns	0	5	ns
	tbhz	UB#, LB# disable to High-Z output	0	20	ns	0	5	ns	0	5	ns	0	5	ns
	tohz	Output disable to High-Z output	0	20	ns	0	5	ns	0	5	ns	0	5	ns
	toh	Output hold from Address Change	5		ns	5		ns	5		ns	5		ns

Version			Page Mode											
			C			E								
Performance Grade			-65			-60			-65			-70		
Density			32Mb pSRAM			32Mb pSRAM			32Mb pSRAM			32Mb pSRAM		
3 Volt	Symbol	Parameter	Min	Max	Units	Min	Max	Units	Min	Max	Units	Min	Max	Units
<b>Write</b>	twc	Write cycle time	65	20k	ns	60	20k	ns	65	20k	ns	70	20k	ns
	tcw	Chipselect to end of write	55		ns	50		ns	60		ns	60		ns
	tas	Address set up Time	0		ns	0		ns	0		ns	0		ns
	taw	Address valid to end of write	55		ns	50		ns	60		ns	60		ns
	tbw	UB#, LB# valid to end of write	55		ns	50		ns	60		ns	60		ns
	twp	Write pulse width	55	20k	ns	50		ns	50		ns	50		ns
	twr	Write recovery time	0		ns	0		ns	0		ns	0		ns
	twhz	Write to output High-Z		5	ns		5	ns		5	ns		5	ns
	tdw	Data to write time overlap	25		ns	20		ns	20		ns	20		ns
	tdh	Data hold from write time	0		ns	0		ns	0		ns	0		ns
	tow	End write to output Low-Z	5			5			5			5		
	tow	Write high pulse width	7.5		ns	7.5		ns	7.5		ns	7.5		ns
<b>Other</b>	tpc	Page read cycle	25	20k	ns	25	20k	ns	25	20k	ns	25	20k	ns
	tpa	Page address access time		25	ns		25	ns		25	ns		25	ns
	twpc	Page write cycle	25	20k	ns	25	20k	ns	25	20k	ns	25	20k	ns
	tcp	Chip select high pulse width	10		ns	10		ns	10		ns	10		ns

## AC Characteristics

### (64Mb pSRAM Page Mode)

			Page Mode		
Performance Grade			-70		
Density			64Mb pSRAM		
3 Volt	Symbol	Parameter	Min	Max	Units
<b>Read</b>	trc	Read cycle time	70	20k	ns
	taa	Address Access Time		70	ns
	tco	Chip select to output		70	ns
	toe	Output enable to valid output		25	ns
	tba	UB#, LB# Access time		70	ns
	tlz	Chip select to Low-z output	10		ns
	tblz	UB#, LB# Enable to Low-Z output	10		ns
	tolz	Output enable to Low-Z output	5		ns
	thz	Chip enable to High-Z output	0	5	ns
	tbhz	UB#, LB# disable to High-Z output	0	5	ns
	tohz	Output disable to High-Z output	0	5	ns
	toh	Output hold from Address Change	5		ns

Performance Grade			Page Mode		
			-70		
Density			64Mb pSRAM		
3 Volt	Symbol	Parameter	Min	Max	Units
Write	twc	Write cycle time	70	20k	ns
	tcw	Chipselect to end of write	60		ns
	tas	Address set up Time	0		ns
	taw	Address valid to end of write	60		ns
	tbw	UB#, LB# valid to end of write	60		ns
	twp	Write pulse width	50	20k	ns
	twr	Write recovery time	0		ns
	twhz	Write to output High-Z		5	ns
	tdw	Data to write time overlap	20		ns
	tdh	Data hold from write time	0		ns
	tow	End write to output Low-Z	5		
	tow	Write high pulse width	7.5		ns
Other	tpc	Page read cycle	20	20k	ns
	tpa	Page address access time		20	ns
	twpc	Page write cycle	20	20k	ns
	tcp	Chip select high pulse width	10		ns

## Timing Diagrams

### Read Cycle

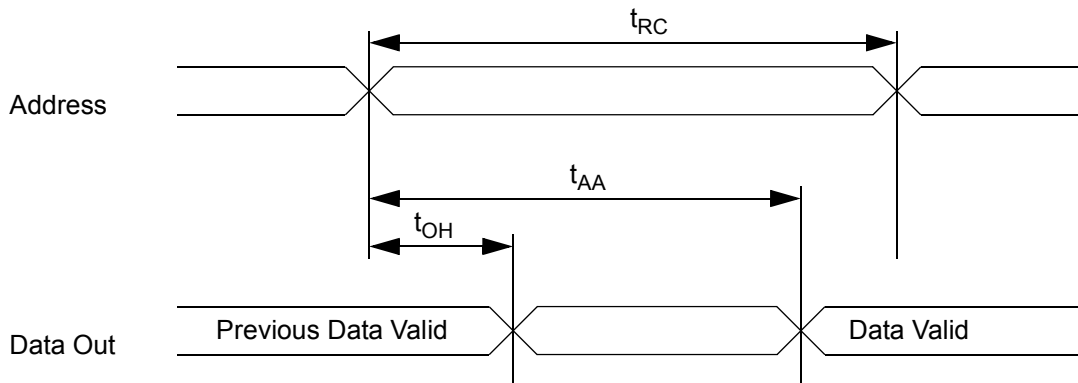

Figure 22. Timing of Read Cycle (CE# = OE# = V<sub>IL</sub>, WE# = ZZ# = V<sub>IH</sub>)

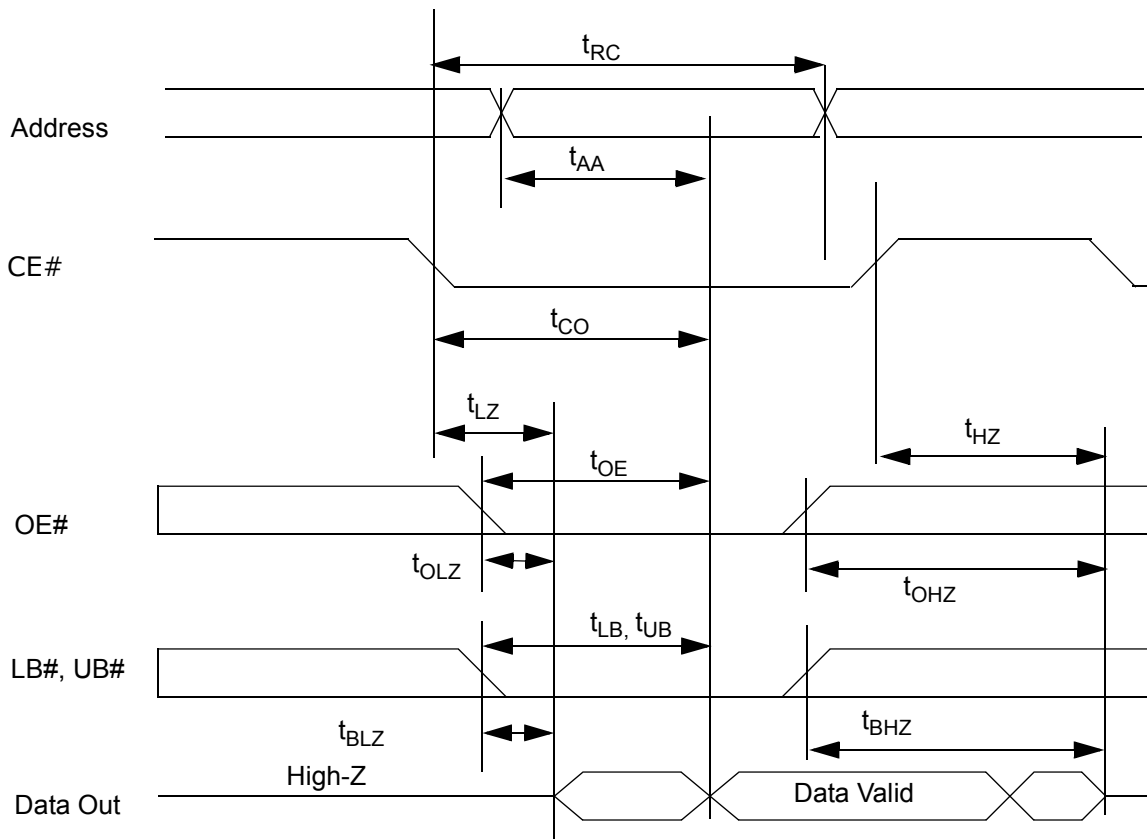

Figure 23. Timing Waveform of Read Cycle (WE# = ZZ# = V<sub>IH</sub>)

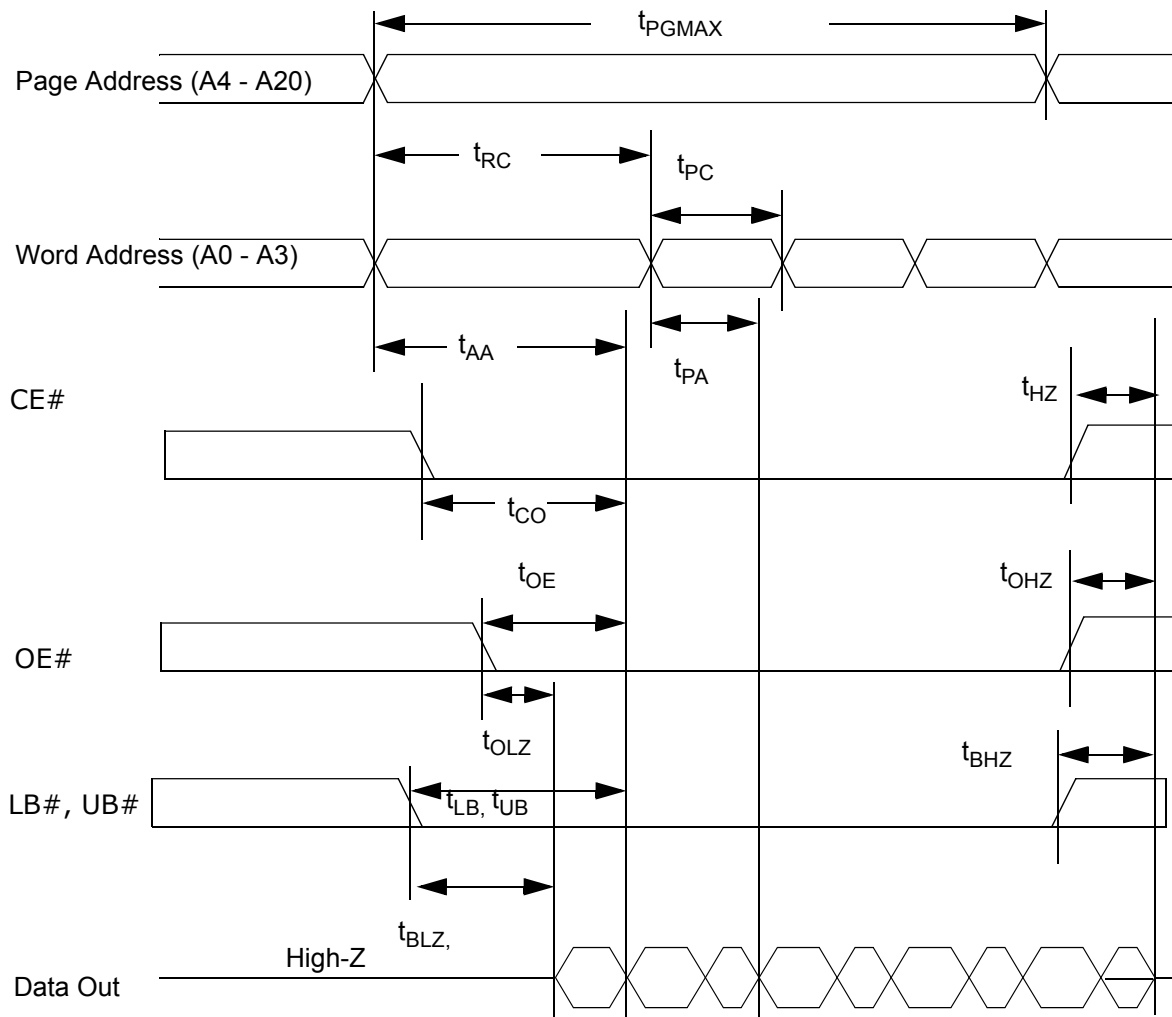

Figure 24. Timing Waveform of Page Mode Read Cycle (WE# = ZZ# = V<sub>IH</sub>)

### Write Cycle

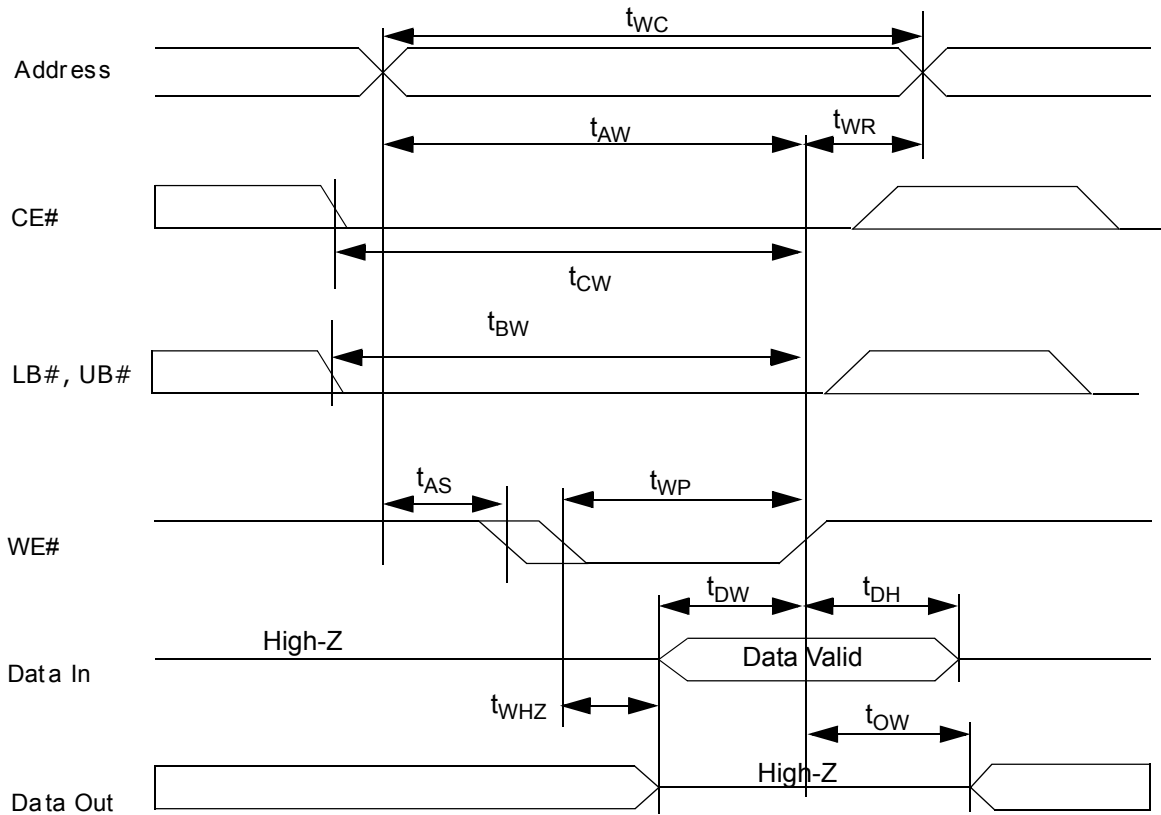

Figure 25. Timing Waveform of Write Cycle (WE# Control, ZZ# = V<sub>IH</sub>)

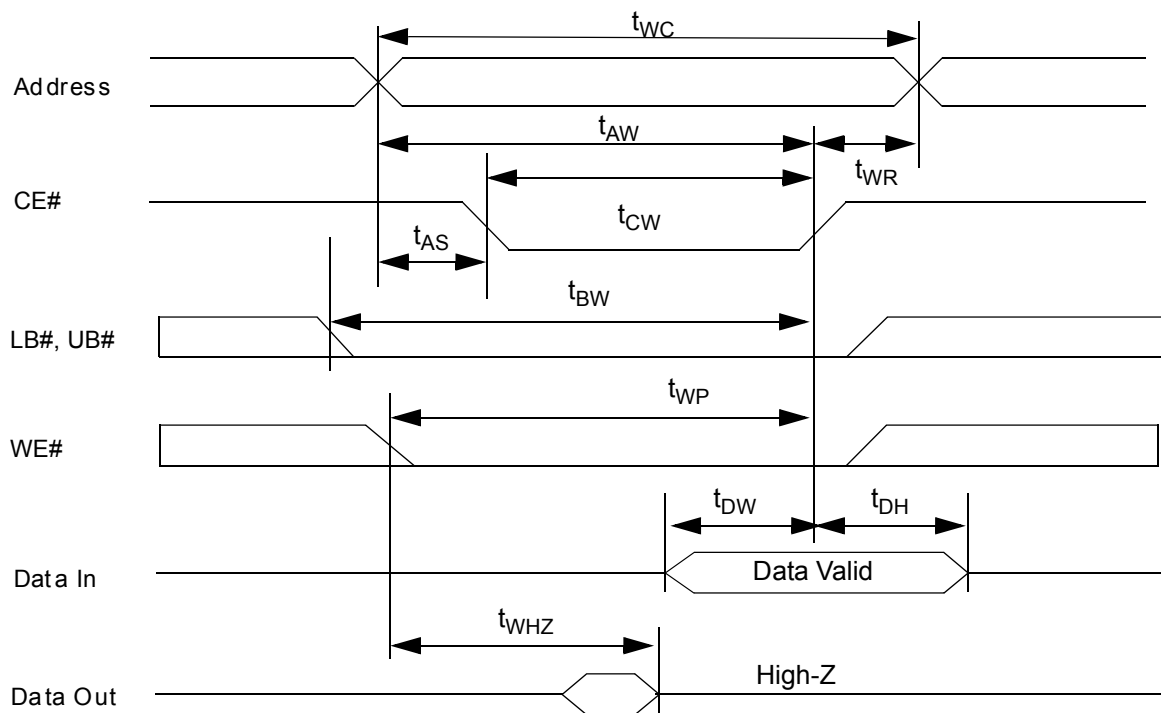

Figure 26. Timing Waveform of Write Cycle (CE# Control, ZZ# = V<sub>IH</sub>)

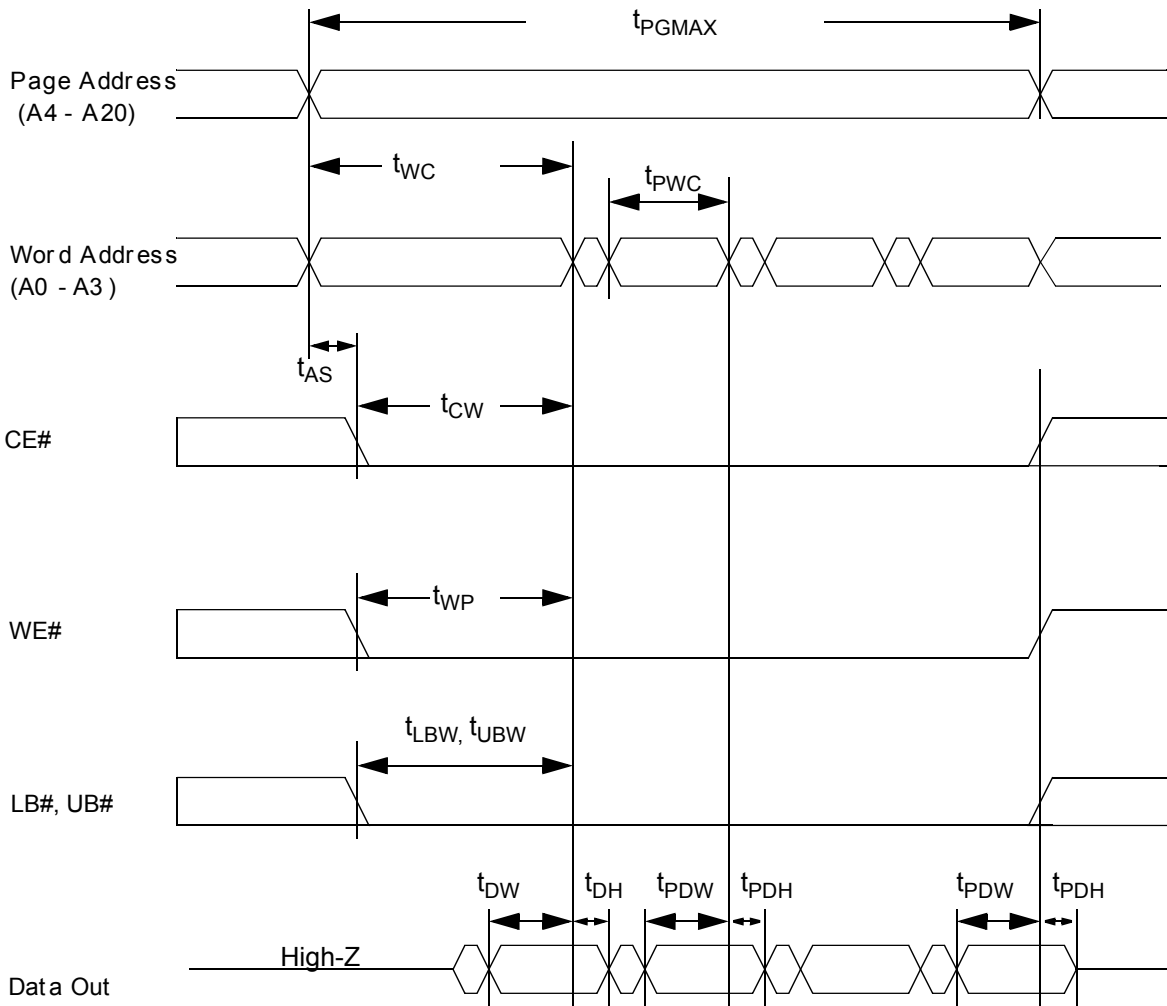

Figure 27. Timing Waveform of Page Mode Write Cycle (ZZ# =  $V_{IH}$ )

## Power Savings Modes (For 16M Page Mode, 32M and 64M Only)

There are several power savings modes.

- Partial Array Self Refresh
- Temperature Compensated Refresh (64M)
- Deep Sleep Mode
- Reduced Memory Size (32M, 16M)

The operation of the power saving modes is controlled by the settings of bits contained in the Mode Register. This definition of the Mode Register is shown in Figure 28 and the various bits are used to enable and disable the various low power modes as well as enabling Page Mode operation. The Mode Register is set by using the timings defined in Figure xxx.

### Partial Array Self Refresh (PAR)

In this mode of operation, the internal refresh operation can be restricted to a 16Mb, 32Mb, or 48Mb portion of the array. The array partition to be refreshed is determined by the respective bit settings in the Mode Register. The register settings for the PASR operation are defined in Table xxx. In this PASR mode, when ZZ# is active low, only the portion of the array that is set in the register is re-



freshed. The data in the remainder of the array will be lost. The PASR operation mode is only available during standby time (ZZ# low) and once ZZ# is returned high, the device resumes full array refresh. All future PASR cycles will use the contents of the Mode Register that has been previously set. To change the address space of the PASR mode, the Mode Register must be reset using the previously defined procedures. For PASR to be activated, the register bit, A4 must be set to a one (1) value, "PASR Enabled". If this is the case, PASR will be activated 10  $\mu$ s after ZZ# is brought low. If the A4 register bit is set equal to zero (0), PASR will not be activated.

### Temperature Compensated Refresh (for 64Mb)

In this mode of operation, the internal refresh rate can be optimized for the operation temperature used and this can then lower standby current. The DRAM array in the PSRAM must be refreshed internally on a regular basis. At higher temperatures, the DRAM cell must be refreshed more often than at lower temperatures. By setting the temperature of operation in the Mode Register, this refresh rate can be optimized to yield the lowest standby current at the given operating temperature. There are four different temperature settings that can be programmed in to the PSRAM. These are defined in Figure 28.

### Deep Sleep Mode

In this mode of operation, the internal refresh is turned off and all data integrity of the array is lost. Deep Sleep is entered by bringing ZZ# low with the A4 register bit set to a zero (0), "Deep Sleep Enabled". If this is the case, Deep Sleep will be entered 10  $\mu$ s after ZZ# is brought low. The device will remain in this mode as long as ZZ# remains low. If the A4 register bit is set equal to one (1), Deep Sleep will not be activated.

### Reduced Memory Size (for 32M and 16M)

In this mode of operation, the 32Mb PSRAM can be operated as a 8Mb or 16Mb device. The mode and array size are determined by the settings in the VA register. The VA register is set according to the following timings and the bit settings in the table "Address Patterns for RMS". The RMS mode is enabled at the time of ZZ transitioning high and the mode remains active until the register is updated. To return to the full 32Mb address space, the VA register must be reset using the previously defined procedures. While operating in the RMS mode, the unselected portion of the array may not be used.

### Other Mode Register Settings (for 64M)

The Page Mode operation can also be enabled and disabled using the Mode Register. Register bit A7 controls the operation of Page Mode and setting this bit to a one (1), enables Page Mode. If the register bit A7 is set to a zero (0), Page Mode operation is disabled.

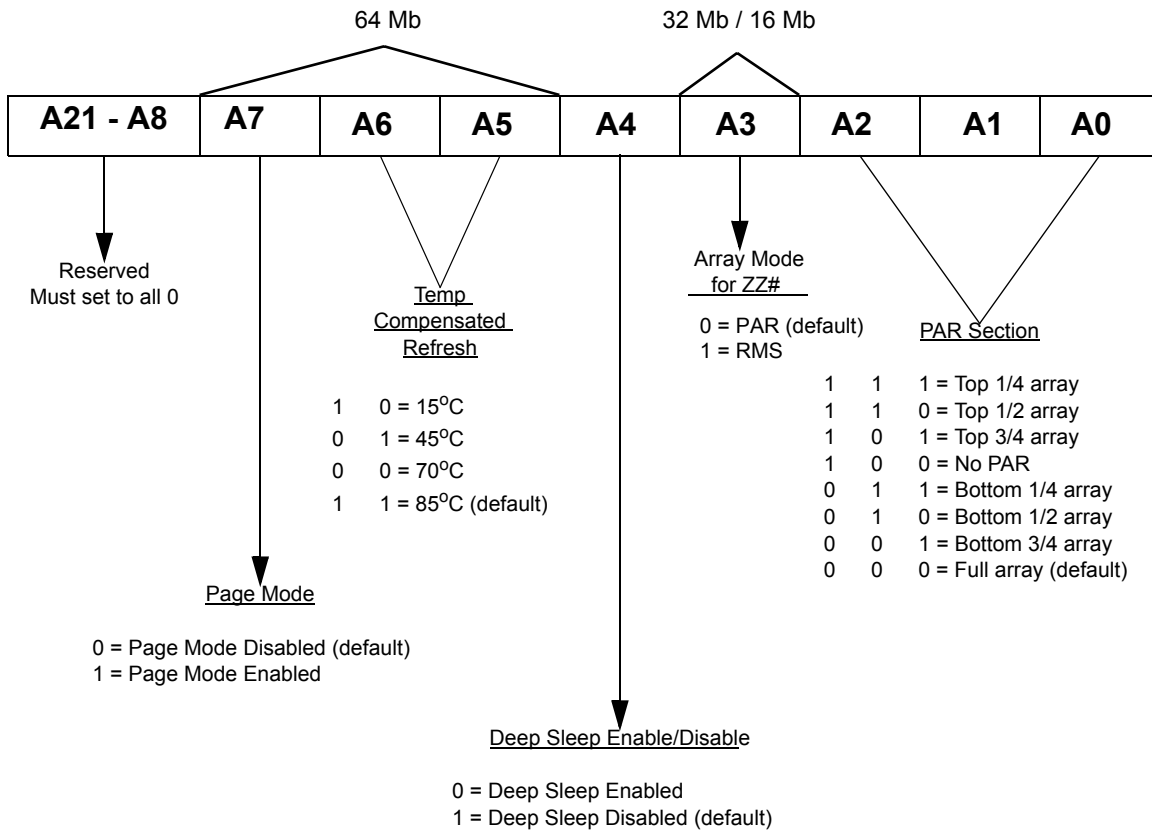

Figure 28. Mode Register

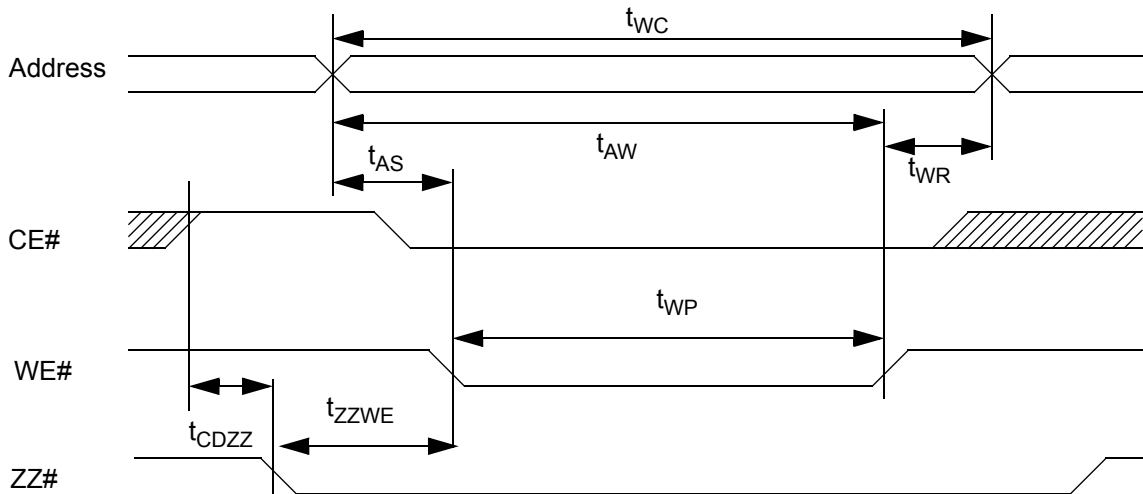

Figure 29. Mode Register Update Timings (UB#, LB#, OE# are Don't Care)

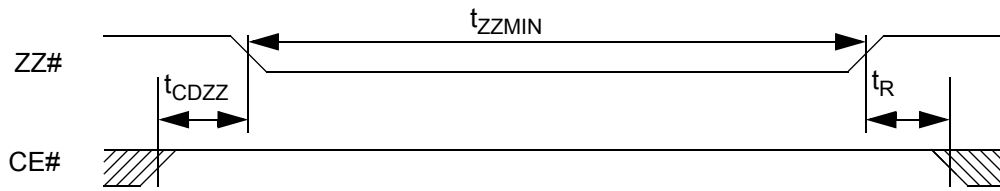

Figure 30. Deep Sleep Mode - Entry/Exit Timings (for 64M)

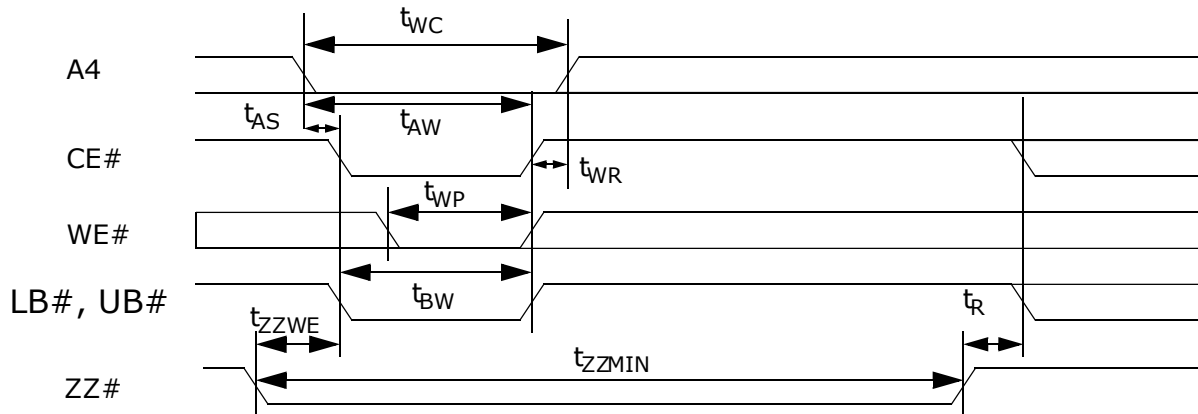

Figure 31. Deep Sleep Mode - Entry/Exit Timings (for 32M and 16M)

### Mode Register Update and Deep Sleep Timings

Item	Symbol	Min	Max	Unit	Note
Chip deselect to ZZ# low	$t_{CDZZ}$	5		ns	
ZZ# low to WE# low	$t_{ZZWE}$	10	500	ns	
Write register cycle time	$t_{WC}$	70/85		ns	1
Chip enable to end of write	$t_{CW}$	70/85		ns	1
Address valid to end of write	$t_{AW}$	70/85		ns	1
Write recovery time	$t_{WR}$	0		ns	
Address setup time	$t_{AS}$	0		ns	
Write pulse width	$t_{WR}$	40		ns	
Deep Sleep Pulse Width	$t_{ZZMIN}$	10		$\mu$ s	
Deep Sleep Recovery	$t_R$	200		$\mu$ s	

**Notes:**

1. Minimum cycle time for writing register is equal to speed grade of product.

### Address Patterns for PASR (A4=I) (64M)

A2	A1	A0	Active Section	Address Space	Size	Density
1	1	1	Top quarter of die	300000h-3FFFFFFh	1Mb x 16	16Mb
1	1	0	Top half of die	200000h-3FFFFFFh	2Mb x 16	32Mb
1	0	1	Reserved			
1	0	0	No PASR	None	0	0
0	1	1	Bottom quarter of die	000000h-0FFFFFFh	1Mb x 16	16Mb
0	1	0	Bottom half of die	000000h-1FFFFFFh	2Mb x 16	32Mb
0	0	1	Reserved			
0	0	0	Full array	000000h-3FFFFFFh	4Mb x 16	64Mb

### Deep ICC Characteristics (for 64Mb)

Item	Symbol	Test	Array Partition	Typ	Max	Unit
PASR Mode Standby Current	$I_{PASR}$	$V_{IN} = V_{CC}$ or 0V, Chip Disabled, $t_A = 85^\circ\text{C}$	None		10	$\mu\text{A}$
			1/4 Array		60	
			1/2 Array		80	
			Full Array		120	

Item	Symbol	Max Temperature	Typ	Max	Unit
Temperature Compensated Refresh Current	$I_{TCR}$	15°C		50	$\mu\text{A}$
		45°C		60	
		70°C		80	
		85°C		120	

Item	Symbol	Test	Typ	Max	Unit
Deep Sleep Current	$I_{ZZ}$	$V_{IN} = V_{CC}$ or 0V, Chip in ZZ# mode, $t_A = 25^\circ\text{C}$		10	$\mu\text{A}$

### Address Patterns for PAR (A3= 0, A4=I) (32M)

A2	A1	A0	Active Section	Address Space	Size	Density
0	1	1	One-quarter of die	000000h - 07FFFFh	512Kb x 16	8Mb
0	1	0	One-half of die	000000h - 0FFFFFFh	1Mb x 16	16Mb
x	0	0	Full die	000000h - 1FFFFFFh	2Mb x 16	32Mb
1	1	1	One-quarter of die	180000h - 1FFFFFFh	512Kb x 16	8Mb
1	1	0	One-half of die	100000h - 1FFFFFFh	1Mb x 16	16Mb

**Address Patterns for RMS (A3 = 1, A4 = 1) (32M)**

A2	A1	A0	Active Section	Address Space	Size	Density
0	1	1	One-quarter of die	000000h - 07FFFFh	512Kb x 16	8Mb
0	1	0	One-half of die	000000h - 0FFFFFFh	1Mb x 16	16Mb
1	1	1	One-quarter of die	180000h - 1FFFFFFh	512Kb x 16	8Mb
1	1	0	One-half of die	100000h - 1FFFFFFh	1Mb x 16	16Mb

### Low Power ICC Characteristics (32M)

Item	Symbol	Test	Array Partition	Typ	Max	Unit
PAR Mode Standby Current	$I_{PAR}$	$V_{IN} = V_{CC}$ or 0V, Chip Disabled, $t_A = 85^\circ\text{C}$	1/4 Array		75	$\mu\text{A}$
			1/2 Array		90	$\mu\text{A}$
RMS Mode Standby Current	$I_{RMSSB}$	$V_{IN} = V_{CC}$ or 0V, Chip Disabled, $t_A = 85^\circ\text{C}$	8Mb Device		75	$\mu\text{A}$
			16Mb Device		90	$\mu\text{A}$
Deep Sleep Current	$I_{ZZ}$	$V_{IN} = V_{CC}$ or 0V, Chip in $\overline{ZZ}$ mode, $t_A = 85^\circ\text{C}$			10	$\mu\text{A}$

### Address Patterns for PAR (A3= 0, A4=I) (16M)

A2	A1	A0	Active Section	Address Space	Size	Density
0	1	1	One-quarter of die	00000h - 0FFFFh	256Kb x 16	4Mb
0	1	0	One-half of die	00000h - 7FFFFh	512Kb x 16	8Mb
x	0	0	Full die	00000h - FFFFFh	1Mb x 16	16Mb
1	1	1	One-quarter of die	C0000h - FFFFh	256Kb x 16	4Mb
1	1	0	One-half of die	80000h - 1FFFFh	512Kb x 16	8Mb

### Address Patterns for RMS (A3 = I, A4 = I) (16M)

A2	A1	A0	Active Section	Address Space	Size	Density
0	1	1	One-quarter of die	00000h - 0FFFFh	256Kb x 16	4Mb
0	1	0	One-half of die	00000h - 7FFFFh	512Kb x 16	8Mb
1	1	1	One-quarter of die	C0000h - FFFFh	256Kb x 16	4Mb
1	1	0	One-half of die	80000h - FFFFFh	512Kb x 16	8Mb

### Low Power ICC Characteristics (16M)

Item	Symbol	Test	Array Partition	Typ	Max	Unit
PAR Mode Standby Current	$I_{PAR}$	$V_{IN} = V_{CC}$ or 0V, Chip Disabled, $t_A = 85^\circ\text{C}$	1/4 Array		65	$\mu\text{A}$
			1/2 Array		80	
RMS Mode Standby Current	$I_{RMSSB}$	$V_{IN} = V_{CC}$ or 0V, Chip Disabled, $t_A = 85^\circ\text{C}$	4Mb Device		65	$\mu\text{A}$
			8Mb Device		80	
Deep Sleep Current	$I_{ZZ}$	$V_{IN} = V_{CC}$ or 0V, Chip in ZZ# mode, $t_A = 85^\circ\text{C}$			10	$\mu\text{A}$

## pSRAM Type 7

16Mb (1M word x 16-bit)

32Mb (2M word x 16-bit)

64Mb (4M word x 16-bit)

**CMOS 1M/2M/4M-Word x 16 bit Fast Cycle Random Access Memory with Low Power SRAM Interface**

### Features

- Asynchronous SRAM Interface
- Fast Access Time
  - $t_{CE} = t_{AA} = 60\text{ns}$  max (16M)
  - $t_{CE} = t_{AA} = 65\text{ns}$  max (32M/64M)
- 8 words Page Access Capability
  - $t_{PAA} = 20\text{ns}$  max (32M/64M)
- Low Voltage Operating Condition
  - $V_{DD} = +2.7\text{V}$  to  $+3.1\text{V}$
- Wide Operating Temperature
  - $T_A = -30^\circ\text{C}$  to  $+85^\circ\text{C}$
- Byte Control by LB and UB
- Low Power Consumption
  - $I_{DDA1} = 20\text{mA}$  max (16M)
  - $I_{DDA1} = 30\text{mA}$  max (32M)
  - $I_{DDA1} = \text{TBDmA}$  max (64M)
  - $I_{DDS1} = 100\mu\text{A}$  max (16M)
  - $I_{DDS1} = 80\mu\text{A}$  max (32M)
  - $I_{DDS1} = \text{TBD}\mu\text{A}$  max (64M)
- Various Power Down mode
  - Sleep, 4M-bit Partial or 8M-bit Partial (32M)
  - Sleep, 8M-bit Partial or 16M-bit Partial (64M)

### Pin Description

Pin Name	Description
$A_{21}$ to $A_0$	Address Input : $A_{19}$ to $A_0$ for 16M, $A_{20}$ to $A_0$ for 32M, $A_{21}$ to $A_0$ for 64M
CE1#	Chip Enable (Low Active)
CE2#	Chip Enable (High Active)
WE#	Write Enable (Low Active)
OE#	Output Enable (Low Active)
UB#	Upper Byte Control (Low Active)
LB#	Lower Byte Control (Low Active)
$DQ_{16-9}$	Upper Byte Data Input/Output
$DQ_{8-1}$	Lower Byte Data Input/Output
$V_{DD}$	Power Supply

Pin Name	Description
V <sub>SS</sub>	Ground

## Functional Description

Mode	CE2#	CE1#	WE#	OE#	LB#	UB#	A <sub>21-0</sub>	DQ <sub>8-1</sub>	DQ <sub>16-9</sub>	
Standby (Deselect)	H	H	X	X	X	X	X	High-Z	High-Z	
Output Disable (Note 1)	H	L	H	H	X	X	Note 3	High-Z	High-Z	
Output Disable (No Read)			H	L	L	H	H	Valid	High-Z	High-Z
Read (Upper Byte)						H	L	Valid	High-Z	Output Valid
Read (Lower Byte)						L	H	Valid	Output Valid	High-Z
Read (Word)						L	L	Valid	Output Valid	Output Valid
No Write			L	H (Note 4)	H	H	H	Valid	Invalid	Invalid
Write (Upper Byte)						H	L	Valid	Invalid	Input Valid
Write (Lower Byte)						L	H	Valid	Input Valid	Invalid
Write (Word)						L	L	Valid	Input Valid	Input Valid
Power Down			L	X	X	X	X	X	X	High-Z

**Legend:** L = V<sub>IL</sub>, H = V<sub>IH</sub>, X can be either V<sub>IL</sub> or V<sub>IH</sub>, High-Z = High Impedence.

### Notes:

- Should not be kept this logic condition longer than 1ms. Please contact local Spansion representative for the relaxation of 1ms limitation.
- Power Down mode can be entered from Standby state and all DQ pins are in High-Z state. Data retention depends on the selection of Power Down Program, 16M has data retention in all modes except Power Down. Refer to POWER DOWN for the detail.
- Can be either V<sub>IL</sub> or V<sub>IH</sub> but must be valid before Read or Write.
- OE# can be V<sub>IL</sub> during Write operation if the following conditions are satisfied:
  - Write pulse is initiated by CE1# (refer to CE1# Controlled Write timing), or cycle time of the previous operation cycle is satisfied.
  - OE# stays V<sub>IL</sub> during Write cycle

## Power Down (for 32M, 64M Only)

### Power Down

The Power Down is low power idle state controlled by CE2. CE2 Low drives the device in power down mode and maintains low power idle state as long as CE2 is kept Low. CE2 High resumes the device from power down mode. These devices have three power down mode. These can be programmed by series of read/write operation. Each mode has following features.

32M			64M		
Mode	Retention Data	Retention Address	Mode	Retention Data	Retention Address
Sleep (default)	No	N/A	Sleep (default)	No	N/A
4M Partial	4M bit	00000h to 3FFFFh	8M Partial	8M bit	00000h to 7FFFFh
8M Partial	8M bit	00000h to 7FFFFh	16M Partial	16M bit	00000h to FFFFFh



The default state is Sleep and it is the lowest power consumption but all data will be lost once CE2 is brought to Low for Power Down. It is not required to program to Sleep mode after power-up.

### Power Down Program Sequence

The program requires total 6 read/write operation with unique address. Between each read/write operation requires that device be in standby mode. Following table shows the detail sequence.

Cycle #	Operation	Address	Data
1st	Read	3FFFFFFh (MSB)	Read Data (RDa)
2nd	Write	3FFFFFFh	RDa
3rd	Write	3FFFFFFh	RDa
4th	Write	3FFFFFFh	Don't Care (X)
5th	Write	3FFFFFFh	X
6th	Read	Address Key	Read Data (RDb)

The first cycle is to read from most significant address (MSB).

The second and third cycle are to write back the data (RDa) read by first cycle. If the second or third cycle is written into the different address, the program is cancelled and the data written by the second or third cycle is valid as a normal write operation.

The fourth and fifth cycle is to write to MSB. The data of fourth and fifth cycle is don't-care. If the fourth or fifth cycle is written into different address, the program is also cancelled but write data may not be wrote as normal write operation.

The last cycle is to read from specific address key for mode selection.

Once this program sequence is performed from a Partial mode to the other Partial mode, the written data stored in memory cell array may be lost. So, it should perform this program prior to regular read/write operation if Partial mode is used.

### Address Key

The address key has following format.

Mode		Address				
32M	64M	A21	A20	A19	A18 - A0	Binary
Sleep (default)	Sleep (default)	1	1	1	1	3FFFFFFh
4M Partial	N/A	1	1	0	1	37FFFFFFh
8M Partial	8M Partial	1	0	1	1	2FFFFFFh
N/A	16M Partial	1	0	0	1	27FFFFFFh

## Absolute Maximum Ratings

Item	Symbol	Value	Unit
Voltage of $V_{DD}$ Supply Relative to $V_{SS}$	$V_{DD}$	-0.5 to +3.6	V
Voltage at Any Pin Relative to $V_{SS}$	$V_{IN}$ , $V_{OUT}$	-0.5 to +3.6	V
Short Circuit Output Current	$I_{OUT}$	±50	mA
Storage temperature	$T_{STG}$	-55 to +125	°C

**WARNING:** Semiconductor devices can be permanently damaged by application of stress (voltage, current, temperature, etc.) in excess of absolute maximum ratings. Do not exceed these ratings.

## Recommended Operating Conditions (See Warning Below)

Parameter	Symbol	Min	Max	Unit
Supply Voltage	$V_{DD}$	2.7	3.1	V
	$V_{SS}$	0	0	V
High Level Input Voltage (Note 1)	$V_{IH}$	$V_{DD} 0.8$	$V_{DD}+0.2$	V
High Level Input Voltage (Note 1)	$V_{IL}$	-0.3	$V_{DD} 0.2$	V
Ambient Temperature	$T_A$	-30	85	°C

### Notes:

1. Maximum DC voltage on input and I/O pins are  $V_{DD}+0.2V$ . During voltage transitions, inputs may positive overshoot to  $V_{DD}+1.0V$  for periods of up to 5 ns.
2. Minimum DC voltage on input or I/O pins are -0.3V. During voltage transitions, inputs may negative overshoot  $V_{SS}$  to -1.0V for periods of up to 5ns.

**WARNING:** Recommended operating conditions are normal operating ranges for the semiconductor device. All the device's electrical characteristics are warranted when operated within these ranges.

Always use semiconductor devices within the recommended operating conditions. Operation outside these ranges may adversely affect reliability and could result in device failure.

No warranty is made with respect to uses, operating conditions, or combinations not represented on the data sheet. Users considering application outside the listed conditions are advised to contact their FUJITSU representative beforehand.

## Package Capacitance

Test conditions:  $T_A = 25^\circ\text{C}$ ,  $f = 1.0 \text{ MHz}$

Symbol	Description	Test Setup	Typ	Max	Unit
$C_{IN1}$	Address Input Capacitance	$V_{IN} = 0V$	—	5	pF
$C_{IN2}$	Control Input Capacitance	$V_{IN} = 0V$	—	5	pF
$C_{IO}$	Data Input/Output Capacitance	$V_{IO} = 0V$	—	8	pF

## DC Characteristics (Under Recommended Conditions Unless Otherwise Noted)

Parameter	Symbol	Test Conditions	16M		32M		64M		Unit	
			Min.	Max.	Min.	Max.	Min.	Max.		
Input Leakage Current	$I_{LI}$	$V_{IN} = V_{SS}$ to $V_{DD}$	-1.0	+1.0	-1.0	+1.0	-1.0	+1.0	$\mu A$	
Output Leakage Current	$I_{LO}$	$V_{OUT} = V_{SS}$ to $V_{DD}$ , Output Disable	-1.0	+1.0	-1.0	+1.0	-1.0	+1.0	$\mu A$	
Output High Voltage Level	$V_{OH}$	$V_{DD} = V_{DD}(\min)$ , $I_{OH} = -0.5mA$	2.2	—	2.4	—	2.4	—	V	
Output Low Voltage Level	$V_{OL}$	$I_{OL} = 1mA$	—	0.4	—	0.4	—	0.4	V	
$V_{DD}$ Power Down Current	$I_{DDPS}$	$V_{DD} = V_{DD(26)} \max.$ , $V_{IN} = V_{IH}$ or $V_{IL}$ , $CE2 \leq 0.2V$	SLEEP		10	—	10	—	TBD	$\mu A$
	$I_{DDP4}$		4M Partial	N/A		—	40	N/A		$\mu A$
	$I_{DDP8}$		8M Partial	N/A		—	50	—	TBD	$\mu A$
	$I_{DDP16}$		16M Partial	N/A		N/A		—	TBD	$\mu A$
$V_{DD}$ Standby Current	$I_{DDES}$	$V_{DD} = V_{DD(26)} \max.$ , $V_{IN} = V_{IH}$ or $V_{IL}$ , $CE1 = CE2 = V_{IH}$	—	1	—	1.5	—	TBD	mA	
	$I_{DDES1}$	$V_{DD} = V_{DD(26)} \max.$ , $V_{IN} \leq 0.2V$ or $V_{IN} \geq V_{DD} - 0.2V$ , $CE1 = CE2 \geq V_{DD} - 0.2V$	—	100	—	80	—	TBD	$\mu A$	
$V_{DD}$ Active Current	$I_{DDA1}$	$V_{DD} = V_{DD(26)} \max.$ , $V_{IN} = V_{IH}$ or $V_{IL}$ , $CE1 = V_{IL}$ and $CE2 = V_{IH}$ , $I_{OUT} = 0mA$	$t_{RC} / t_{WC}$ = minimum	—	20	—	30	—	TBD	mA
	$I_{DDA2}$		$t_{RC} / t_{WC}$ = $1\mu s$	—	3	—	3	—	TBD	mA
$V_{DD}$ Page Read Current	$I_{DDA3}$	$V_{DD} = V_{DD(26)} \max.$ , $V_{IN} = V_{IH}$ or $V_{IL}$ , $CE1 = V_{IL}$ and $CE2 = V_{IH}$ , $I_{OUT} = 0mA$ , $t_{PRC} = \min.$	N/A		—	10	—	TBD	mA	

**Notes:**

1. All voltages are referenced to  $V_{SS}$ .
2. DC Characteristics are measured after following POWER-UP timing.
3.  $I_{OUT}$  depends on the output load conditions.

## AC Characteristics (Under Recommended Operating Conditions Unless Otherwise Noted)

### Read Operation

Parameter	Symbol	16M		32M		64M		Unit	Notes
				Min.	Max.	Min.	Max.		
Read Cycle Time	$t_{RC}$	70	1000	65	1000	65	1000	ns	1, 2
CE1# Access Time	$t_{CE}$	—	60	—	65	—	65	ns	3
OE# Access Time	$t_{OE}$	—	40	—	40	—	40	ns	3
Address Access Time	$t_{AA}$	—	60	—	65	—	65	ns	3, 5
LB# / UB# Access Time	$t_{BA}$	—	30	—	30	—	30	ns	3
Page Address Access Time	$t_{PAA}$	N/A		—	20	—	20	ns	3,6
Page Read Cycle Time	$t_{PRC}$	N/A		20	1000	20	1000	ns	1, 6, 7
Output Data Hold Time	$t_{OH}$	5	—	5	—	5	—	ns	3
CE1# Low to Output Low-Z	$t_{CLZ}$	5	—	5	—	5	—	ns	4
OE# Low to Output Low-Z	$t_{OLZ}$	0	—	0	—	0	—	ns	4
LB# / UB# Low to Output Low-Z	$t_{BLZ}$	0	—	0	—	0	—	ns	4
CE1# High to Output High-Z	$t_{CHZ}$	—	20	—	20	—	20	ns	3
OE# High to Output High-Z	$t_{OHZ}$	—	20	—	15	—	20	ns	3
LB# / UB# High to Output High-Z	$t_{BHZ}$	—	20	—	20	—	20	ns	3
Address Setup Time to CE1# Low	$t_{ASC}$	-5	—	-5	—	-5	—	ns	
Address Setup Time to OE# Low	$t_{ASO}$	10	—	10	—	10	—	ns	
Address Invalid Time	$t_{AX}$	—	10	—	10	—	10	ns	5, 8
Address Hold Time from CE1# High	$t_{CHAH}$	-6	—	-6	—	-6	—	ns	9
Address Hold Time from OE# High	$t_{OHAH}$	-6	—	-6	—	-6	—	ns	
WE# High to OE# Low Time for Read	$t_{WHOL}$	10	1000	12	—	12	—	ns	10
CE1# High Pulse Width	$t_{CP}$	10	—	12	—	12	—	ns	

#### Notes:

1. Maximum value is applicable if CE#1 is kept at Low without change of address input of A3 to A21. If needed by system operation, please contact local Spansion representative for the relaxation of 1 $\mu$ s limitation.
2. Address should not be changed within minimum  $t_{RC}$ .
3. The output load 50pF.
4. The output load 5pF.

5. *Applicable to A3 to A21 (32M and 64M) when CE1# is kept at Low.*
6. *Applicable only to A0, A1 and A2 (32M and 64M) when CE1# is kept at Low for the page address access.*
7. *In case Page Read Cycle is continued with keeping CE1# stays Low, CE1# must be brought to High within 4 $\mu$ s. In other words, Page Read Cycle must be closed within 4 $\mu$ s.*
8. *Applicable when at least two of address inputs among applicable are switched from previous state.*
9. *t<sub>RC</sub>(min) and t<sub>PRC</sub>(min) must be satisfied.*
10. *If actual value of t<sub>WHOL</sub> is shorter than specified minimum values, the actual t<sub>AA</sub> of following Read may become longer by the amount of subtracting actual value from specified minimum value.*

## AC Characteristics

### Write Operation

Parameter	Symbol	16M		32M		64M		Unit	Notes
		Min.	Max.	Min.	Max.	Min.	Max.		
Write Cycle Time	$t_{WC}$	70	1000	65	1000	65	1000	ns	1,2
Address Setup Time	$t_{AS}$	0	—	0	—	0	—	ns	3
CE1# Write Pulse Width	$t_{CW}$	45	—	40	—	40	—	ns	3
WE# Write Pulse Width	$t_{WP}$	45	—	40	—	40	—	ns	3
LB#/UB# Write Pulse Width	$t_{BW}$	45	—	40	—	40	—	ns	3
LB#/UB# Byte Mask Setup Time	$t_{BS}$	-5	—	-5	—	-5	—	ns	4
LB#/UB# Byte Mask Hold Time	$t_{BH}$	-5	—	-5	—	-5	—	ns	5
Write Recovery Time	$t_{WR}$	0	—	0	—	0	—	ns	6
CE1# High Pulse Width	$t_{CP}$	10	—	12	—	12	—	ns	
WE# High Pulse Width	$t_{WHP}$	7.5	1000	7.5	1000	7.5	1000	ns	7
LB#/UB# High Pulse Width	$t_{BHP}$	10	1000	12	1000	12	1000	ns	
Data Setup Time	$t_{DS}$	15	—	12	—	12	—	ns	
Data Hold Time	$t_{DH}$	0	—	0	—	0	—	ns	
OE# High to CE1# Low Setup Time for Write	$t_{OHCL}$	-5	—	-5	—	-5	—	ns	8
OE# High to Address Setup Time for Write	$t_{OES}$	0	—	0	—	0	—	ns	9
LB# and UB# Write Pulse Overlap	$t_{BWO}$	30	—	30	—	30	—	ns	

**Notes:**

1. Maximum value is applicable if CE1# is kept at Low without any address change. If the relaxation is needed by system operation, please contact local Spansion representative for the relaxation of 1 $\mu$ s limitation.
2. Minimum value must be equal or greater than the sum of write pulse ( $t_{CW}$ ,  $t_{WP}$  or  $t_{BW}$ ) and write recovery time ( $t_{WR}$ ).
3. Write pulse is defined from High to Low transition of CE1#, WE#, or LB#/UB#, whichever occurs last.
4. Applicable for byte mask only. Byte mask setup time is defined to the High to Low transition of CE1# or WE# whichever occurs last.
5. Applicable for byte mask only. Byte mask hold time is defined from the Low to High transition of CE1# or WE# whichever occurs first.
6. Write recovery is defined from Low to High transition of CE1#, WE#, or LB#/UB#, whichever occurs first.
7.  $t_{WPH}$  minimum is absolute minimum value for device to detect High level. And it is defined at minimum  $V_{IH}$  level.
8. If OE# is Low after minimum  $t_{OHCL}$ , read cycle is initiated. In other words, OE# must be brought to High within 5ns after CE1# is brought to Low. Once read cycle is initiated, new write pulse should be input after minimum  $t_{RC}$  is met.
9. If OE# is Low after new address input, read cycle is initiated. In other word, OE# must be brought to High at the same time or before new address valid. Once read cycle is initiated, new write pulse should be input after minimum  $t_{RC}$  is met and data bus is in High-Z.

## AC Characteristics

### Power Down Parameters

Parameter	Symbol	16M		32M		64M		Unit	Note
		Min.	Max.	Min.	Max.	Min.	Max.		
CE2 Low Setup Time for Power Down Entry	$t_{CSP}$	10	—	10	—	10	—	ns	
CE2 Low Hold Time after Power Down Entry	$t_{C2LP}$	80	—	65	—	65	—	ns	
CE1# High Hold Time following CE2 High after Power Down Exit [SLEEP mode only]	$t_{CHH}$	300	—	300	—	300	—	$\mu s$	1
CE1# High Hold Time following CE2 High after Power Down Exit [not in SLEEP mode]	$t_{CHHP}$	N/A		1	—	1	—	$\mu s$	2
CE1# High Setup Time following CE2 High after Power Down Exit	$t_{CHS}$	0	—	0	—	0	—	ns	1

**Notes:**

1. Applicable also to power-up.
2. Applicable when 4M and 8M Partial mode is programmed.

### Other Timing Parameters

Parameter	Symbol	16M		32M		64M		Unit	Note
		Min.	Max.	Min.	Max.	Min.	Max.		
CE1# High to OE# Invalid Time for Standby Entry	$t_{CHOX}$	10	—	10	—	10	—	ns	
CE1# High to WE# Invalid Time for Standby Entry	$t_{CHWX}$	10	—	10	—	10	—	ns	1
CE2 Low Hold Time after Power-up	$t_{C2LH}$	N/A		50	—	50	—	$\mu s$	
CE1# High Hold Time following CE2 High after Power-up	$t_{CHH}$	300	—	300	—	300	—	$\mu s$	
Input Transition Time	$t_T$	1	25	1	25	1	25	ns	2

**Notes:**

1. Some data might be written into any address location if  $t_{CHWX}(min)$  is not satisfied.
2. The Input Transition Time ( $t_T$ ) at AC testing is 5ns as shown in below. If actual  $t_T$  is longer than 5ns, it may violate AC specification of some timing parameters.

## AC Characteristics

### AC Test Conditions

Symbol	Description	Test Setup	Value	Unit	Note
$V_{IH}$	Input High Level		$V_{DD} * 0.8$	V	
$V_{IL}$	Input Low Level		$V_{DD} * 0.2$	V	
$V_{REF}$	Input Timing Measurement Level		$V_{DD} * 0.5$	V	
$t_T$	Input Transition Time	Between $V_{IL}$ and $V_{IH}$	5	ns	

### AC Measurement Output Load Circuit

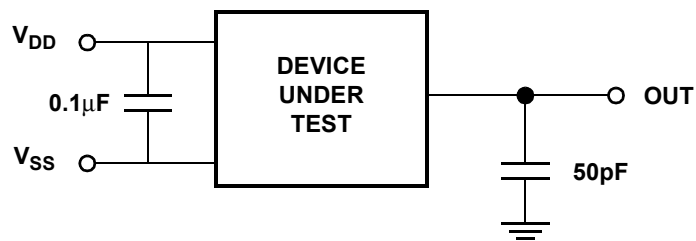
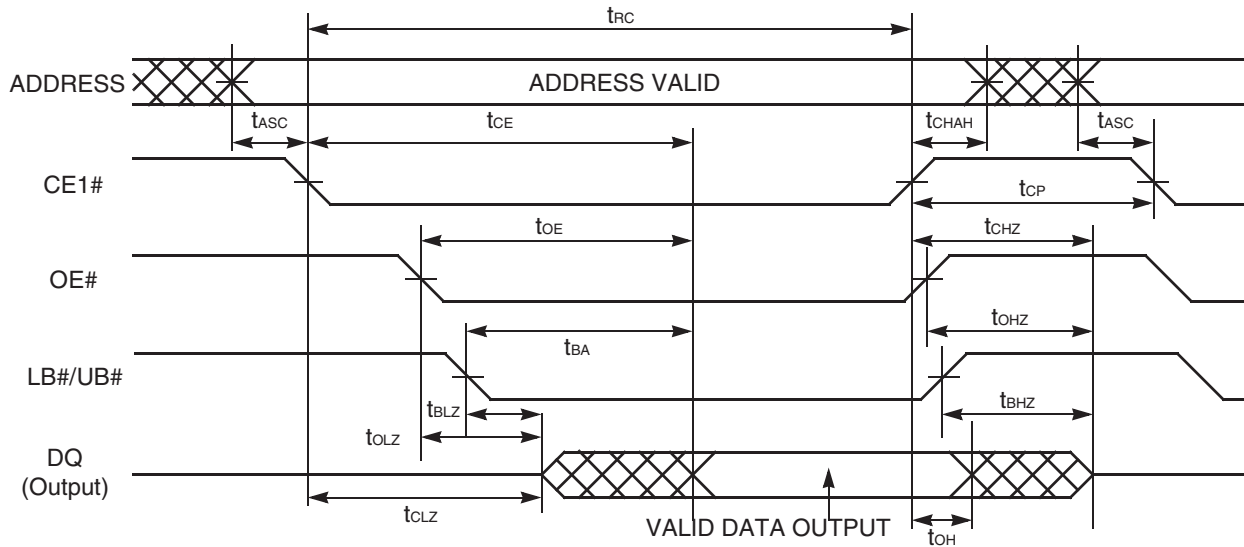

Figure 32. AC Output Load Circuit



# Timing Diagrams

## Read Timings



**Figure 33. Read Timing #1 (Basic Timing)**

**Note:** This timing diagram assumes CE2=H and WE#=H.

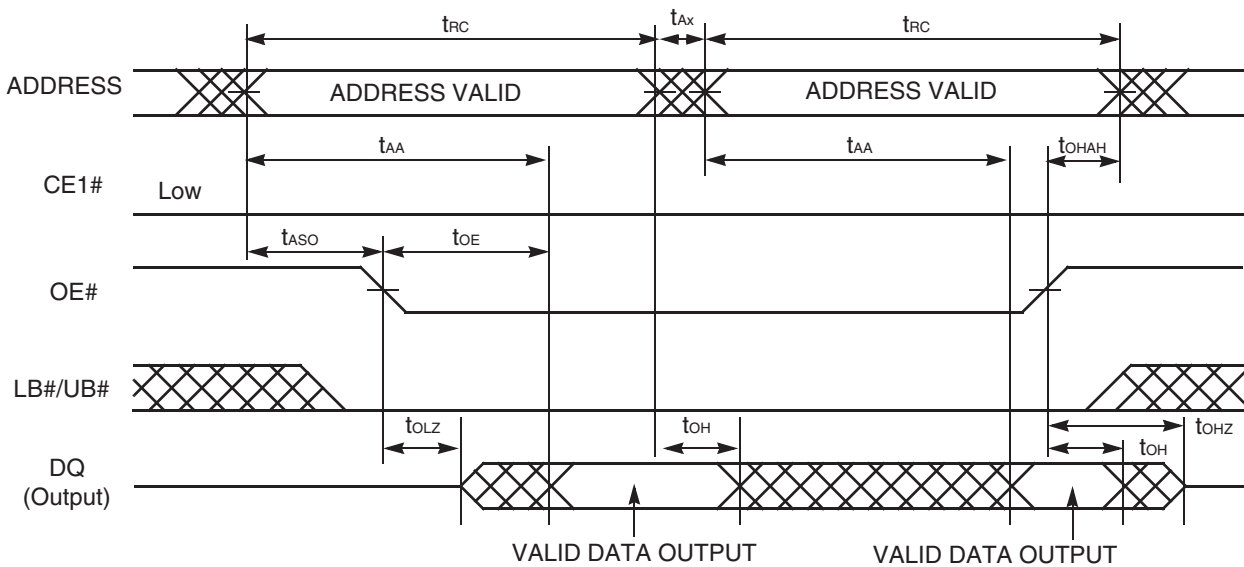

**Figure 34. Read Timing #2 (OE# Address Access)**

**Note:** This timing diagram assumes CE2=H and WE#=H.

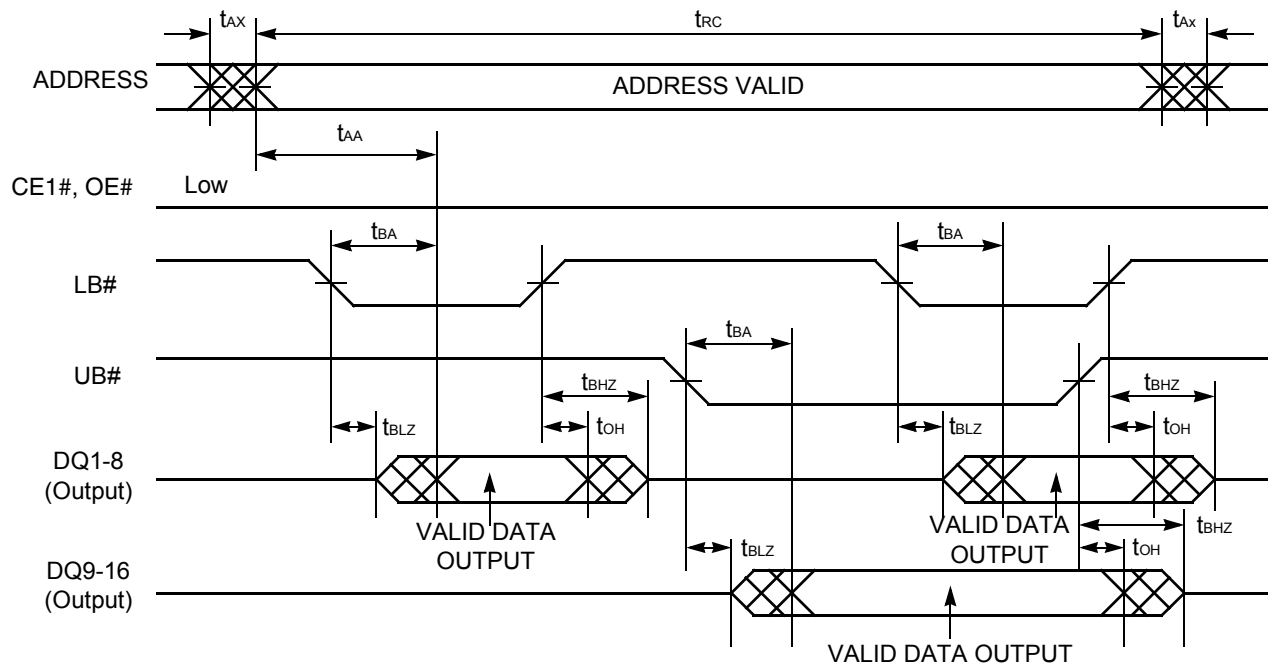

Figure 35. Read Timing #3 (LB#/UB# Byte Access)

**Note:** This timing diagram assumes CE2=H and WE#=H.

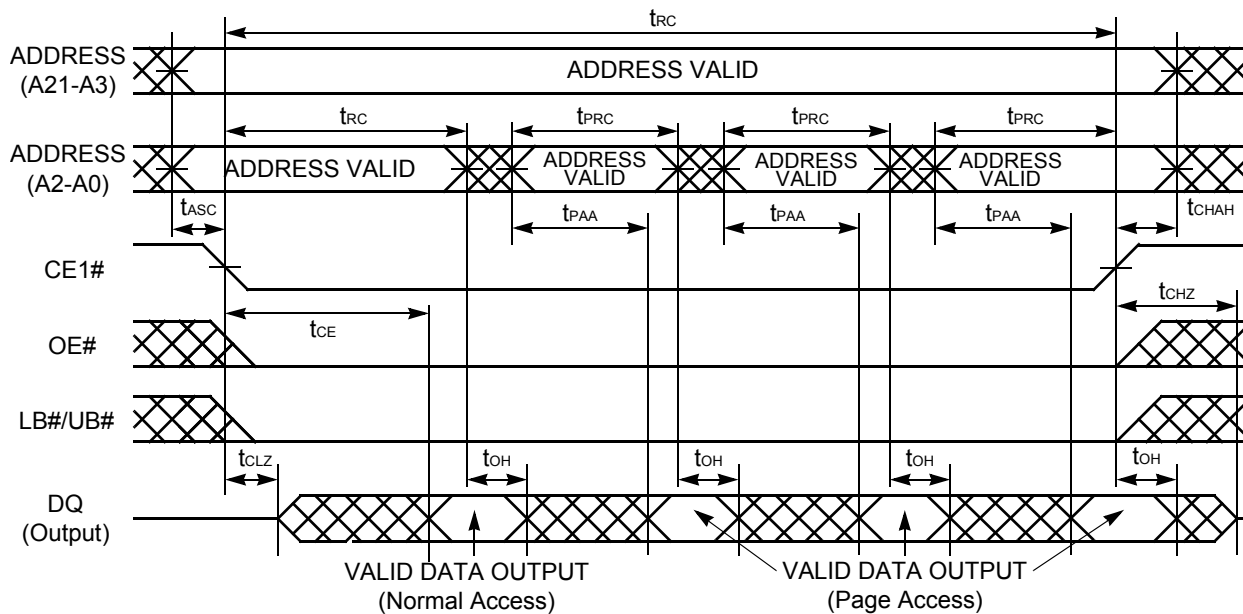
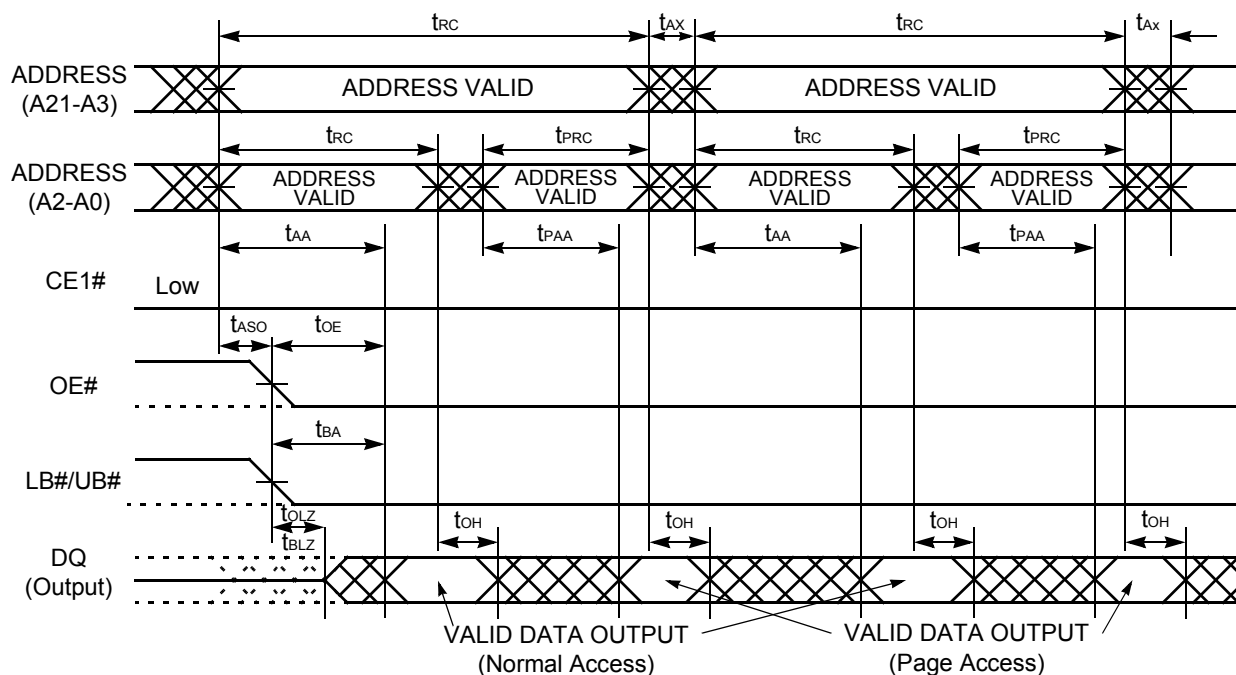

Figure 36. Read Timing #4 (Page Address Access after CEI# Control Access for 32M and 64M Only)

**Note:** This timing diagram assumes CE2=H and WE#=H.

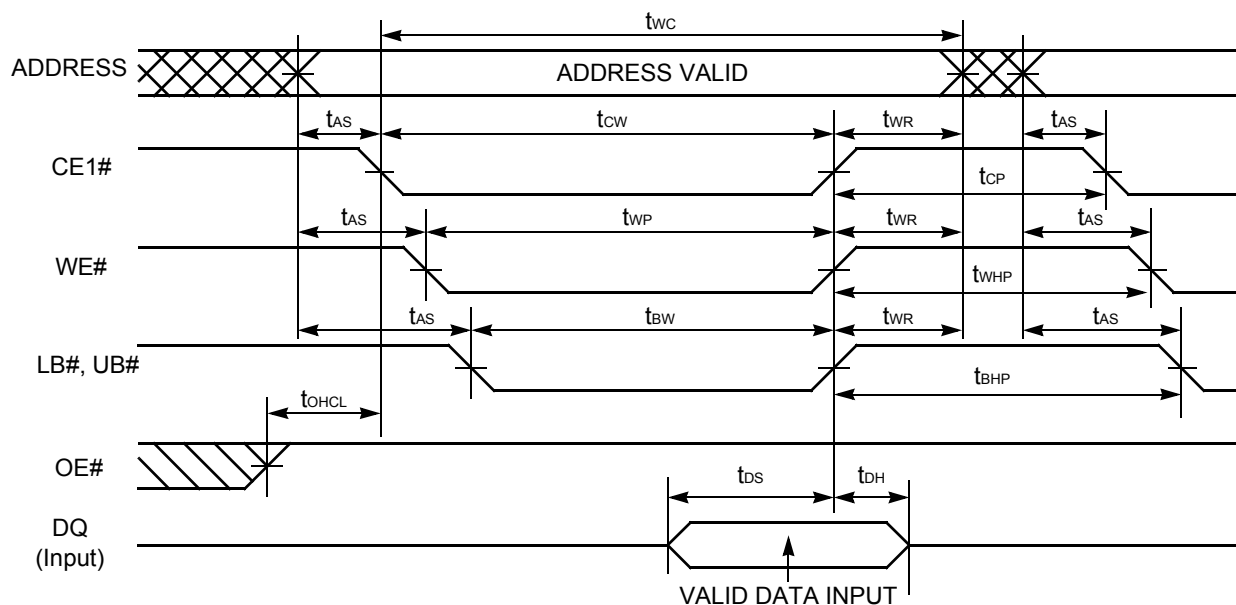

**Figure 37. Read Timing #5 (Random and Page Address Access for 32M and 64M Only)**

**Notes:**

1. This timing diagram assumes CE2=H and WE#=H.
2. Either or both LB# and UB# must be Low when both CE1# and OE# are Low.

**Write Timings**



**Figure 38. Write Timing #1 (Basic Timing)**

**Note:** This timing diagram assumes CE2=H.

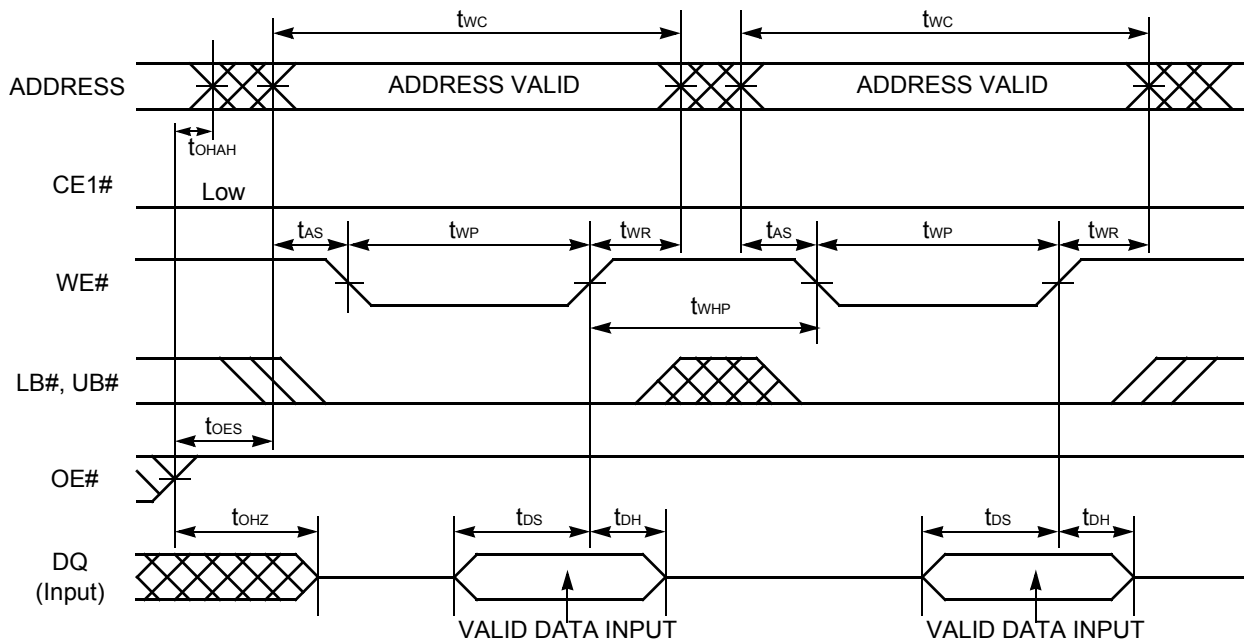

Figure 39. Write Timing #2 (WE# Control)

Note: This timing diagram assumes CE2=H.

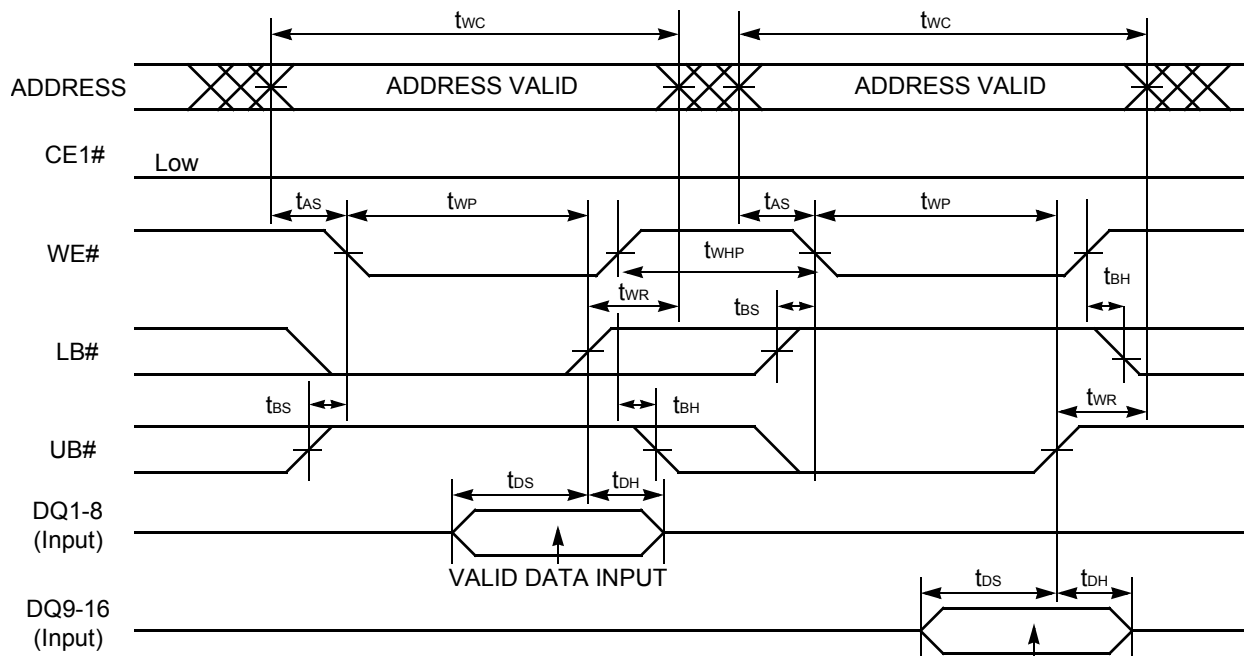

Figure 40. Write Timing #3-I (WE#/LB#/UB# Byte Write Control)

Note: This timing diagram assumes CE2=H and OE#=H.

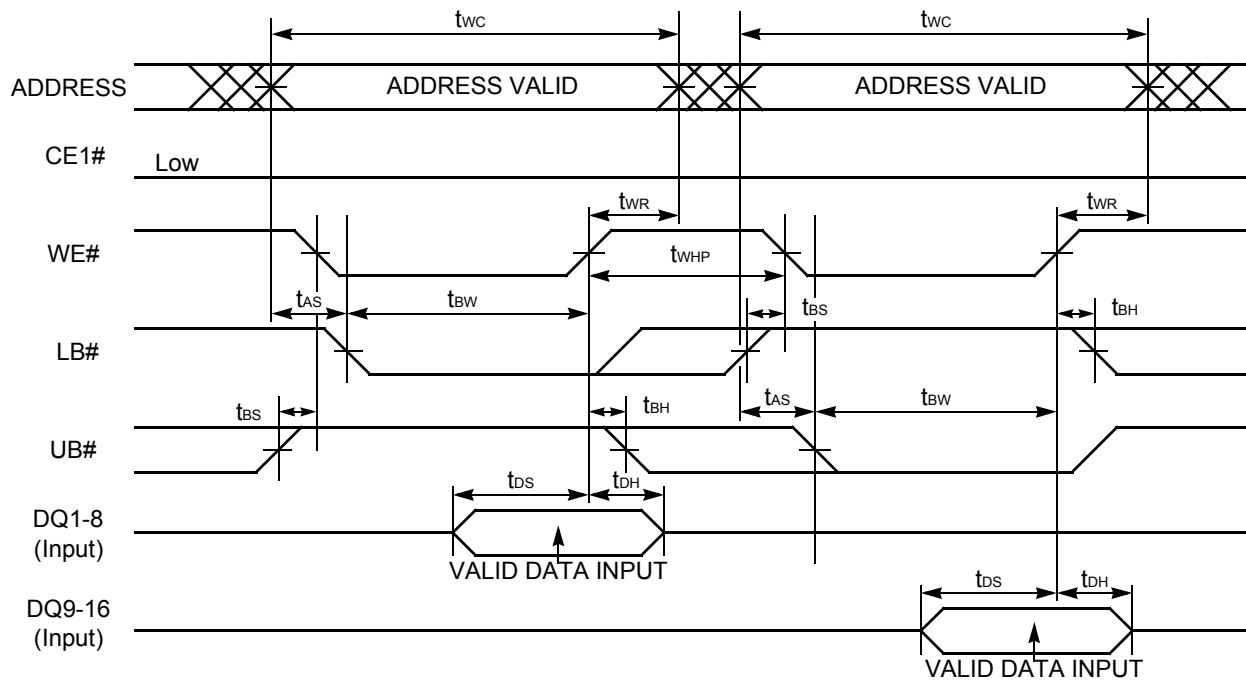

Figure 41. Write Timing #3-2 (WE#/LB#/UB# Byte Write Control)

**Note:** This timing diagram assumes CE2=H and OE#=H.

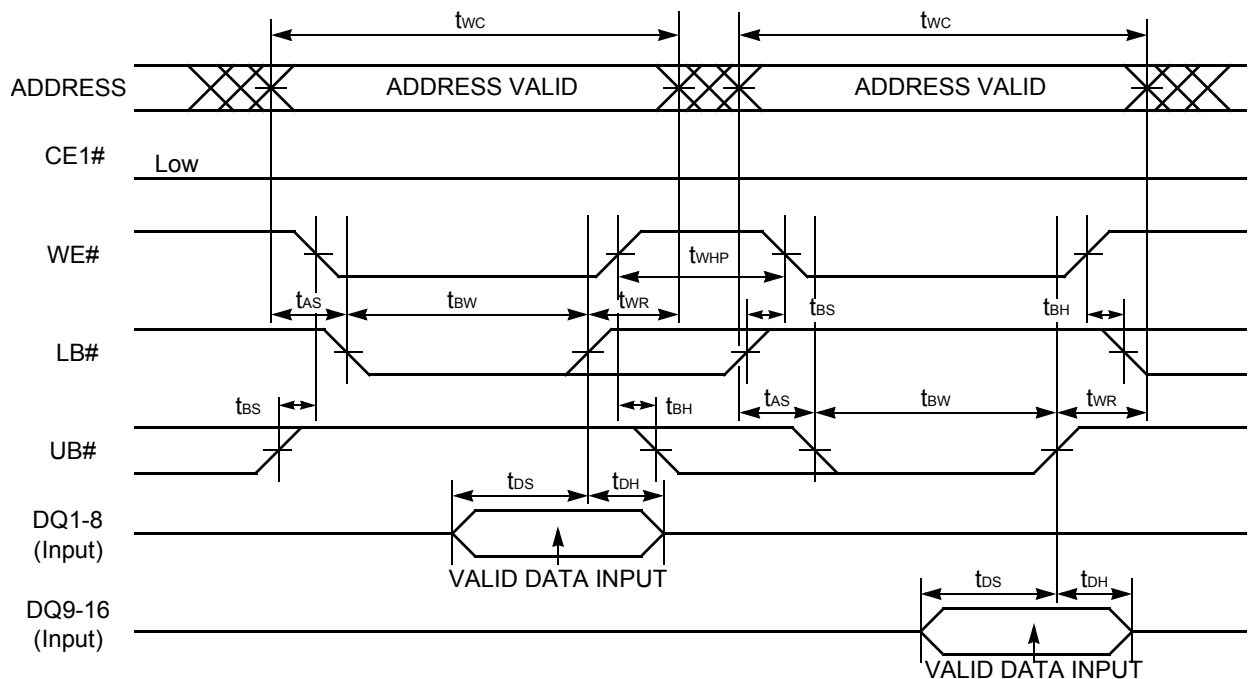
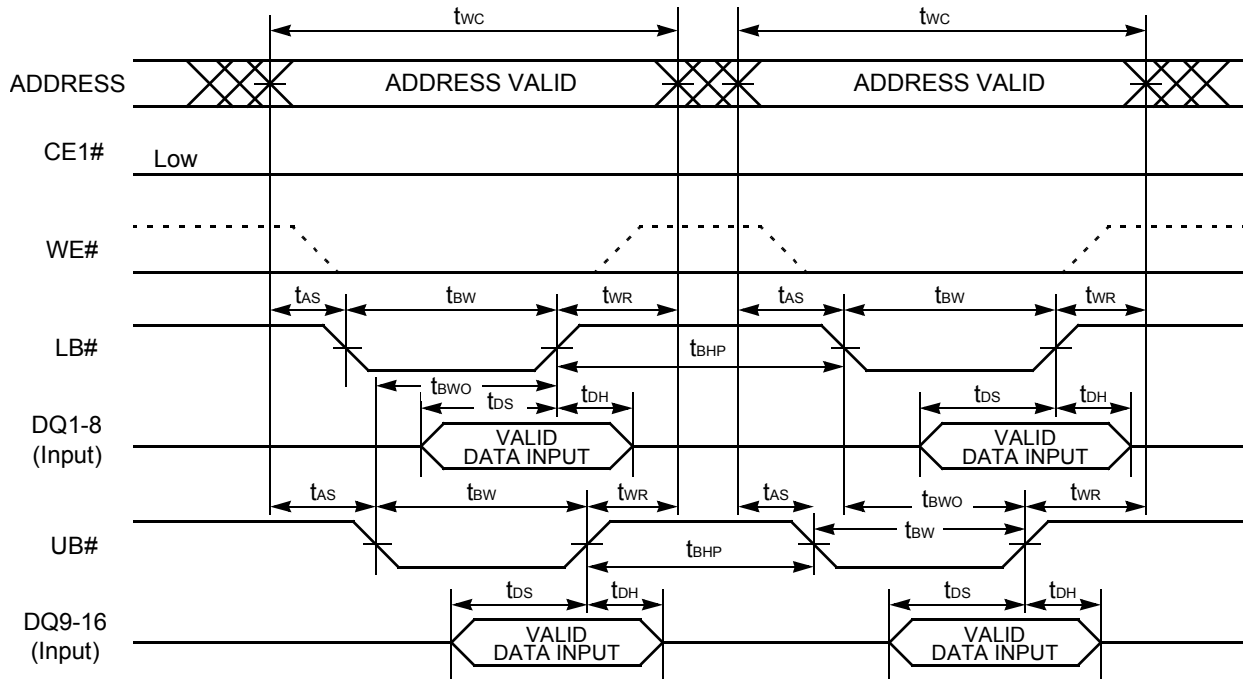

Figure 42. Write Timing #3-3 (WE#/LB#/UB# Byte Write Control)

**Note:** This timing diagram assumes CE2=H and OE#=H.



**Figure 43. Write Timing #3-4 (WE#/LB#/UB# Byte Write Control)**

**Note:** This timing diagram assumes CE2=H and OE#=H.

### Read/Write Timings

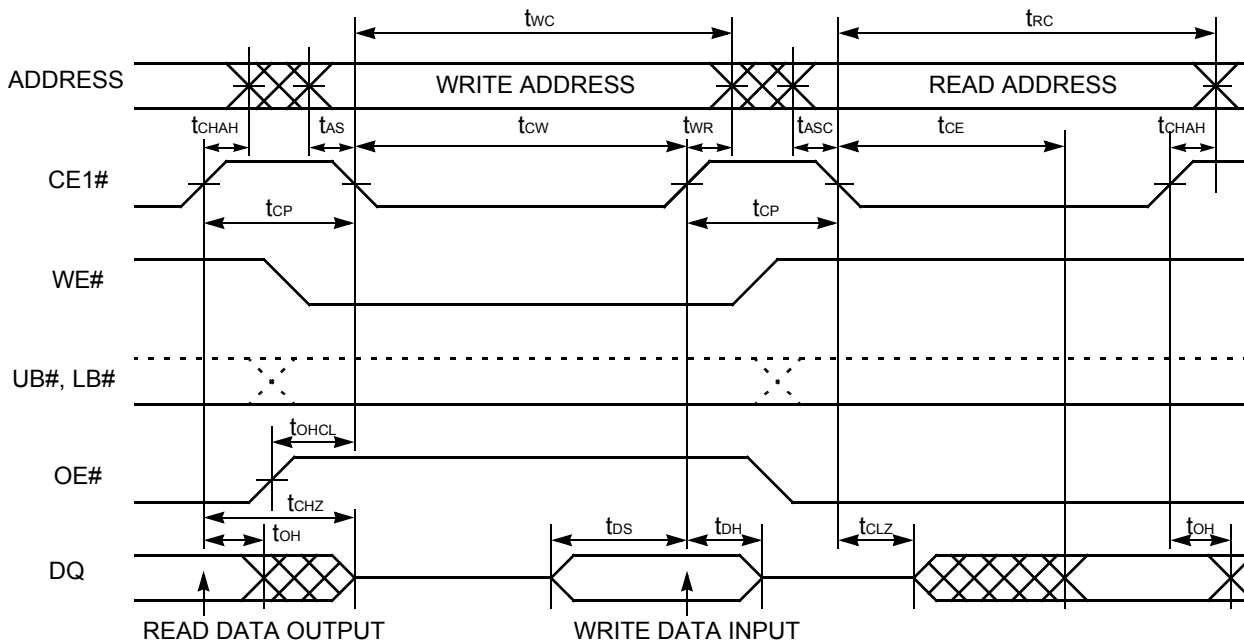

**Figure 44. Read/Write Timing #1-1 (CE1# Control)**

**Notes:**

1. This timing diagram assumes CE2=H.
2. Write address is valid from either CE1# or WE# of last falling edge.

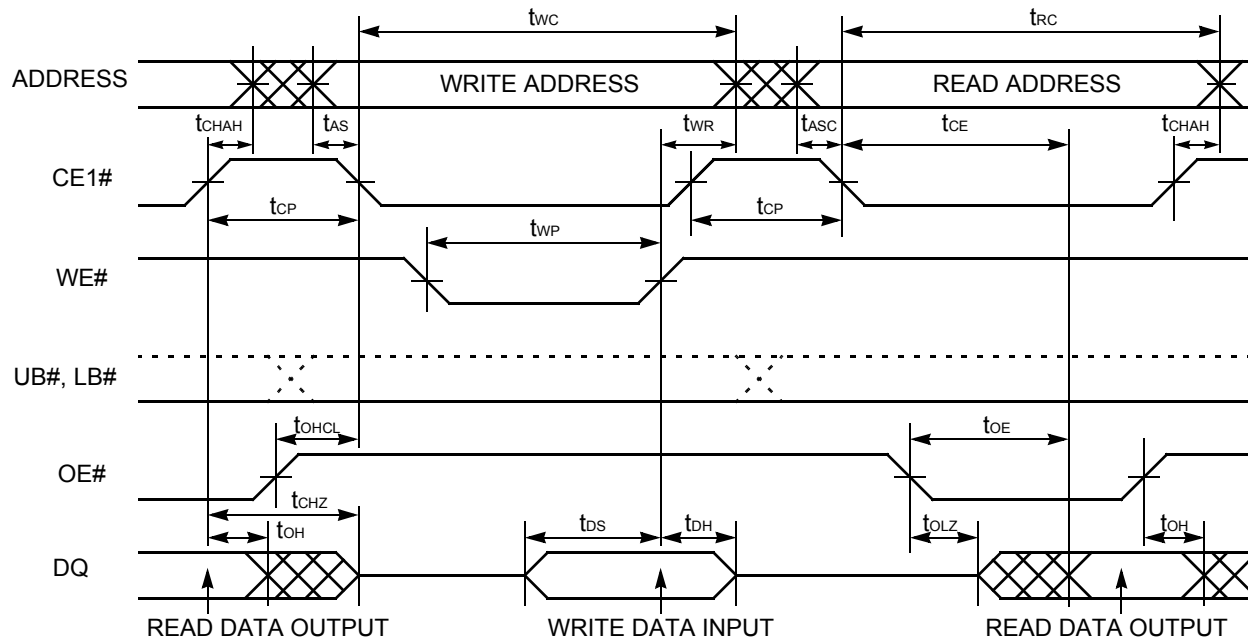

**Figure 45. Read / Write Timing #1-2 (CE1#/WE#/OE# Control)**

**Notes:**

1. This timing diagram assumes CE2=H.
2. OE# can be fixed Low during write operation if it is CE1# controlled write at Read-Write-Read sequence.

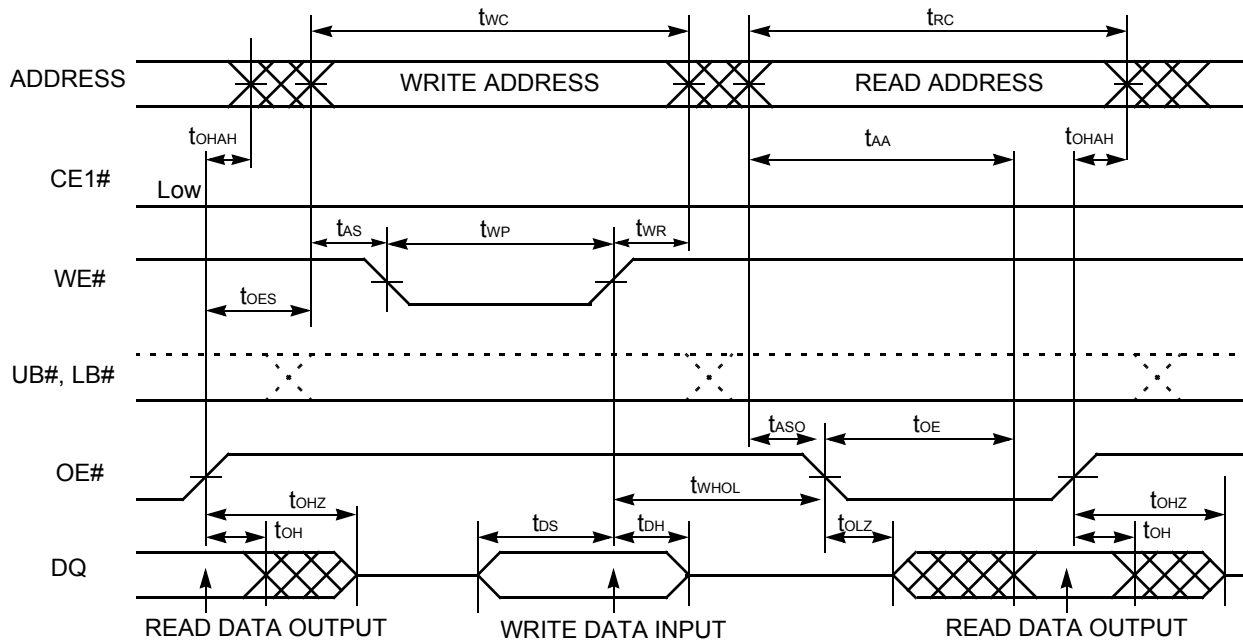

**Figure 46. Read / Write Timing #2 (OE#, WE# Control)**

**Notes:**

1. This timing diagram assumes CE2=H.
2. CE1# can be tied to Low for WE# and OE# controlled operation.

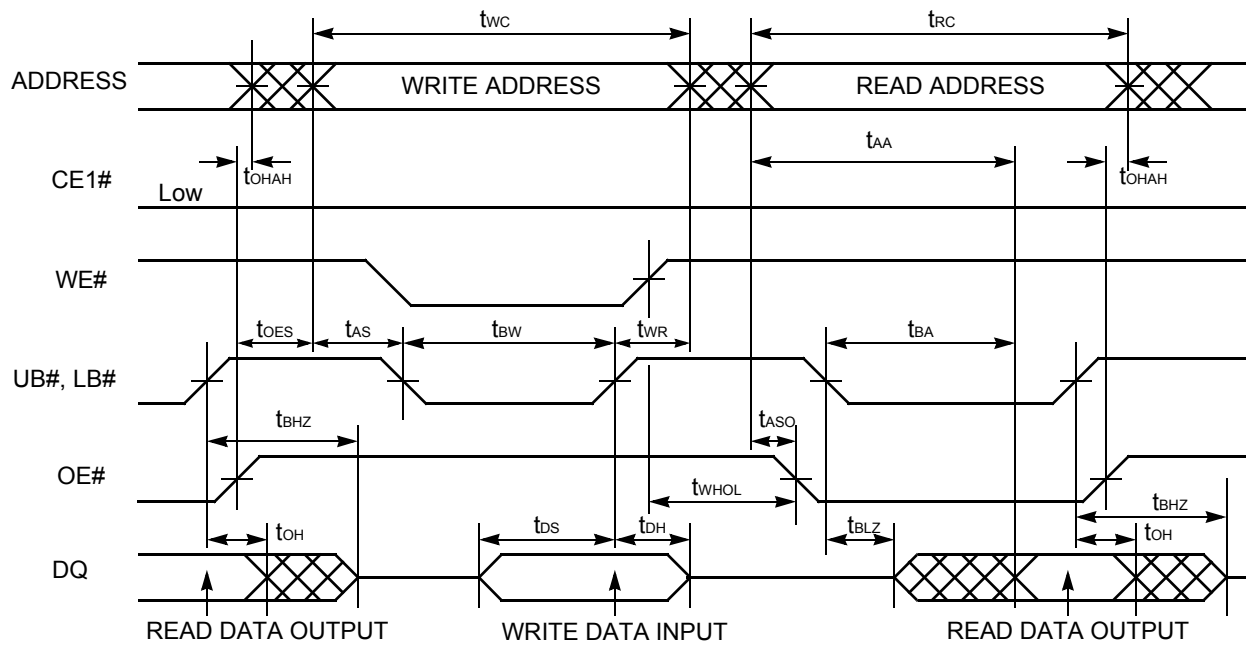

Figure 47. Read / Write Timing #3 (OE#, WE#, LB#, UB# Control)

**Notes:**

1. This timing diagram assumes CE2=H.
2. CE1# can be tied to Low for WE# and OE# controlled operation.

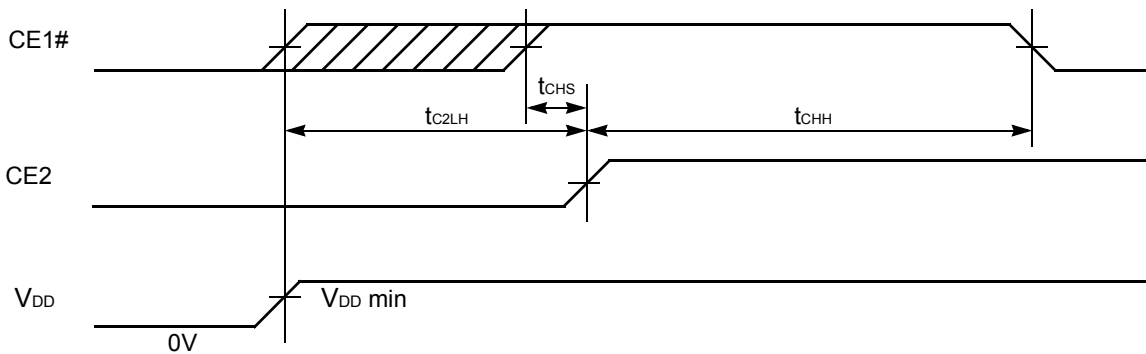
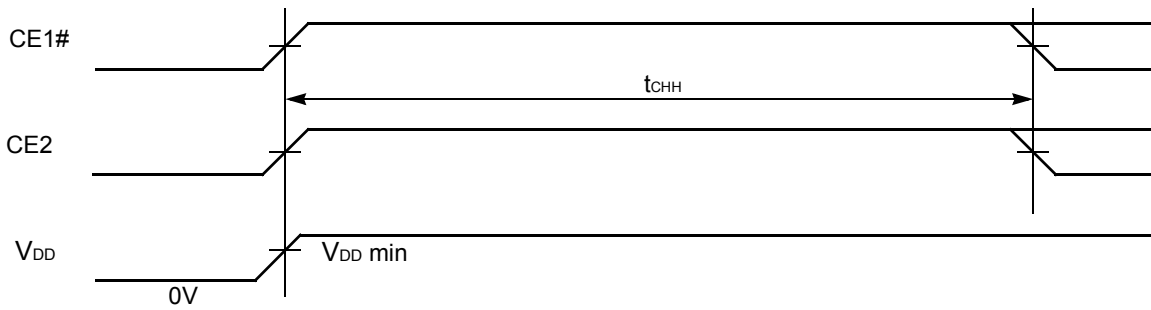

Figure 48. Power-up Timing #1

**Note:** The  $t_{C2LH}$  specifies after  $V_{DD}$  reaches specified minimum level.





**Figure 49. Power-up Timing #2**

**Note:** The  $t_{CHH}$  specifies after  $V_{DD}$  reaches specified minimum level and applicable to both CE1# and CE2.

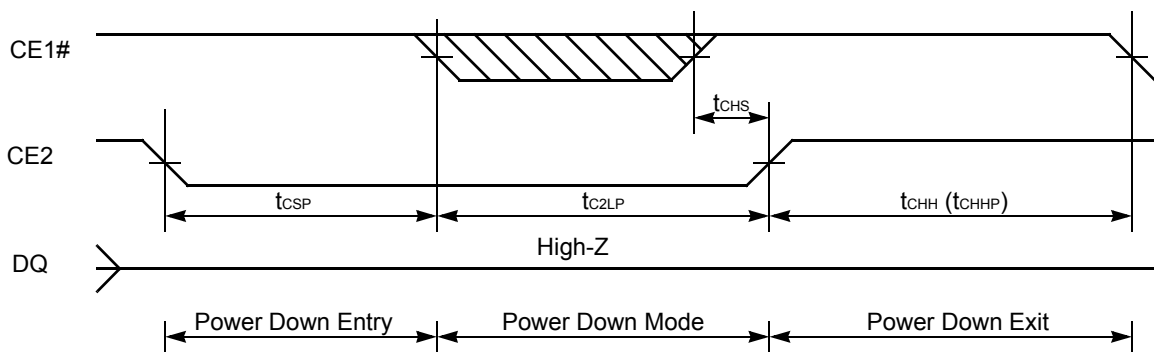

**Figure 50. Power Down Entry and Exit Timing**

**Note:** This Power Down mode can be also used as a reset timing if POWER-UP timing above could not be satisfied and Power-Down program was not performed prior to this reset.

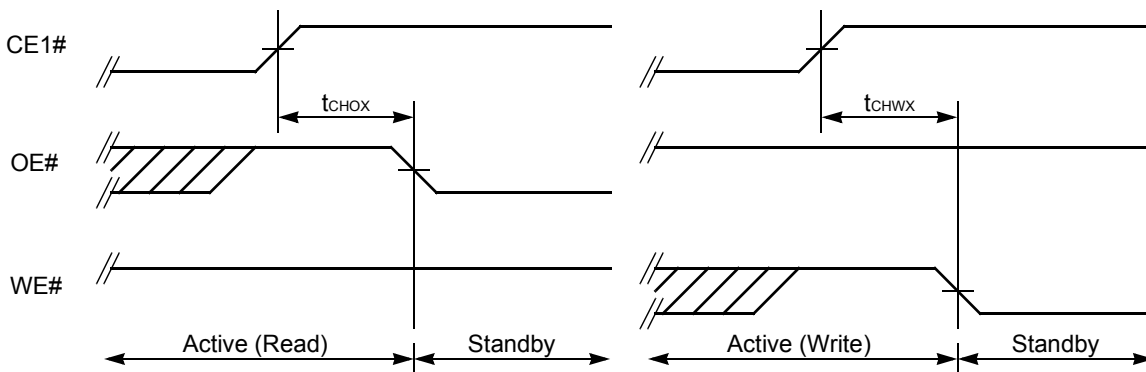

**Figure 51. Standby Entry Timing after Read or Write**

**Note:** Both  $t_{CHOX}$  and  $t_{CHWX}$  define the earliest entry timing for Standby mode. If either of timing is not satisfied, it takes  $t_{RC}$  (min) period for Standby mode from CE1# Low to High transition.

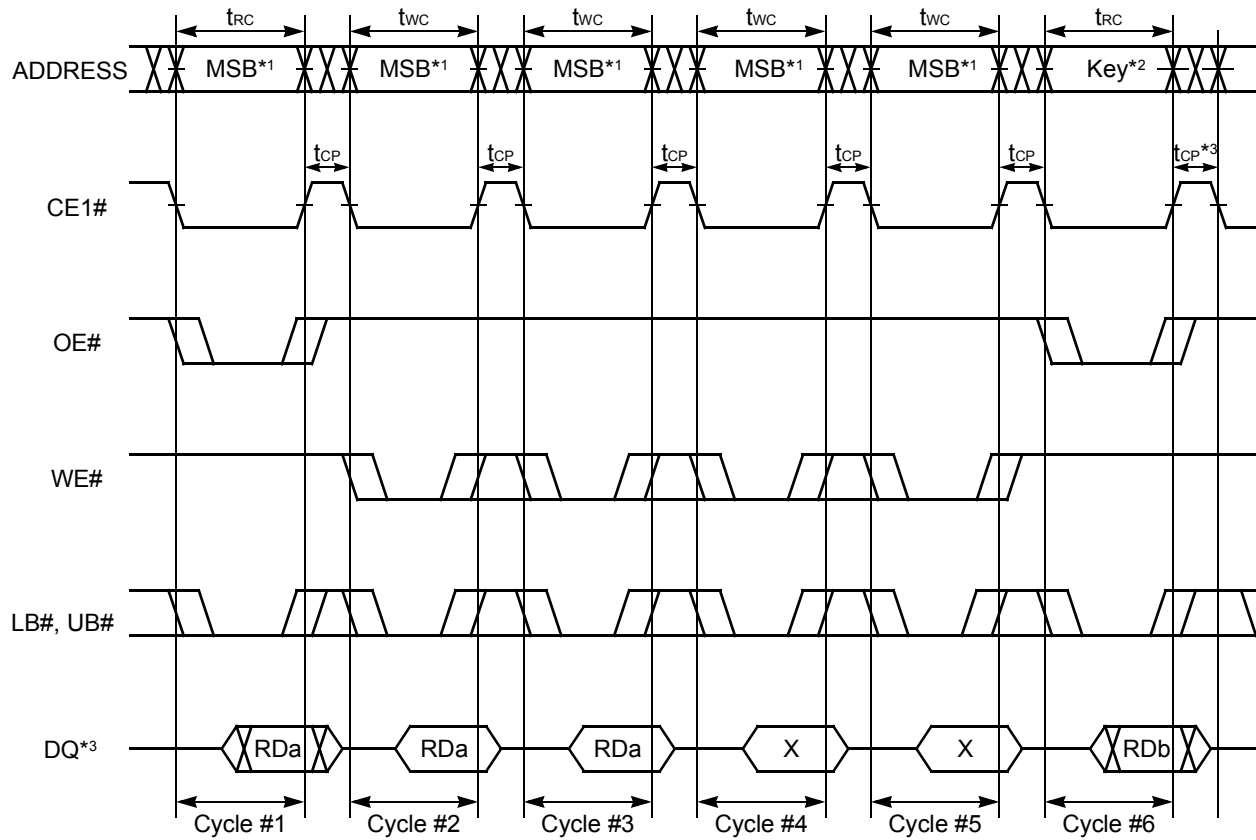

**Figure 52. Power Down Program Timing (for 32M/64M Only)**

**Notes:**

1. The all address inputs must be High from Cycle #1 to #5.
2. The address key must confirm the format specified in page 129. If not, the operation and data are not guaranteed.
3. After  $t_{CP}$  following Cycle #6, the Power Down Program is completed and returned to the normal operation.

## Revision Summary

### Revision A (August 24, 2004)

Initial release.

### Revision AI (December 7, 2004)

#### **Connection Diagrams.**

Added 64-ball pinout.

#### **Ordering Information**

Updated the OPN table.

#### **Valid Combinations tables**

Updated all tables.

### **Colophon**

The products described in this document are designed, developed and manufactured as contemplated for general use, including without limitation, ordinary industrial use, general office use, personal use, and household use, but are not designed, developed and manufactured as contemplated (1) for any use that includes fatal risks or dangers that, unless extremely high safety is secured, could have a serious effect to the public, and could lead directly to death, personal injury, severe physical damage or other loss (i.e., nuclear reaction control in nuclear facility, aircraft flight control, air traffic control, mass transport control, medical life support system, missile launch control in weapon system), or (2) for any use where chance of failure is intolerable ( i.e., submersible repeater and artificial satellite). Please note that Spansion will not be liable to you and/or any third party for any claims or damages arising in connection with above-mentioned uses of the products. Any semiconductor devices have an inherent chance of failure. You must protect against injury, damage or loss from such failures by incorporating safety design measures into your facility and equipment such as redundancy, fire protection, and prevention of over-current levels and other abnormal operating conditions. If any products described in this document represent goods or technologies subject to certain restrictions on export under the Foreign Exchange and Foreign Trade Law of Japan, the US Export Administration Regulations or the applicable laws of any other country, the prior authorization by the respective government entity will be required for export of those products.

### **Trademarks and Notice**

The contents of this document are subject to change without notice. This document may contain information on a Spansion product under development by Spansion LLC. Spansion LLC reserves the right to change or discontinue work on any product without notice. The information in this document is provided as is without warranty or guarantee of any kind as to its accuracy, completeness, operability, fitness for particular purpose, merchantability, non-infringement of third-party rights, or any other warranty, express, implied, or statutory. Spansion LLC assumes no liability for any damages of any kind arising out of the use of the information in this document.

Copyright © 2004 Spansion LLC. All rights reserved. Spansion, the Spansion logo, MirrorBit, combinations thereof, and ExpressFlash are trademarks of Spansion LLC. Other company and product names used in this publication are for identification purposes only and may be trademarks of their respective companies.