

## Features

- 512 channel x 512 channel non-blocking switch at 2.048 Mbps, 4.096 Mbps or 8.192 Mbps operation
- Rate conversion between the ST-BUS inputs and ST-BUS outputs
- Integrated Digital Phase-Locked Loop (DPLL) meets Telcordia GR-1244-CORE Stratum 4 enhanced specifications
- DPLL provides automatic reference switching, jitter attenuation, holdover and free run functions
- Per-stream ST-BUS input with data rate selection of 2.048 Mbps, 4.096 Mbps or 8.192 Mbps
- Per-stream ST-BUS output with data rate selection of 2.048 Mbps, 4.096 Mbps or 8.192 Mbps; the output data rate can be different than the input data rate
- Per-stream high impedance control output for every ST-BUS output with fractional bit advancement
- Per-stream input channel and input bit delay programming with fractional bit delay

## Ordering Information

ZL50010/QCC 160 Pin LQFP  
 ZL50010/GDC 144 Ball LPGA

**-40°C to +85°C**

- Per-stream output channel and output bit delay programming with fractional bit advancement
- Multiple frame pulse outputs and reference clock outputs
- Per-channel constant throughput delay
- Per-channel high impedance output control
- Per-channel message mode
- Per-channel Pseudo Random Bit Sequence (PRBS) pattern generation and bit error detection
- Control interface compatible to Motorola non-multiplexed CPUs
- Connection memory block programming capability
- IEEE-1149.1 (JTAG) test port
- 3.3 V I/O with 5 V tolerant input

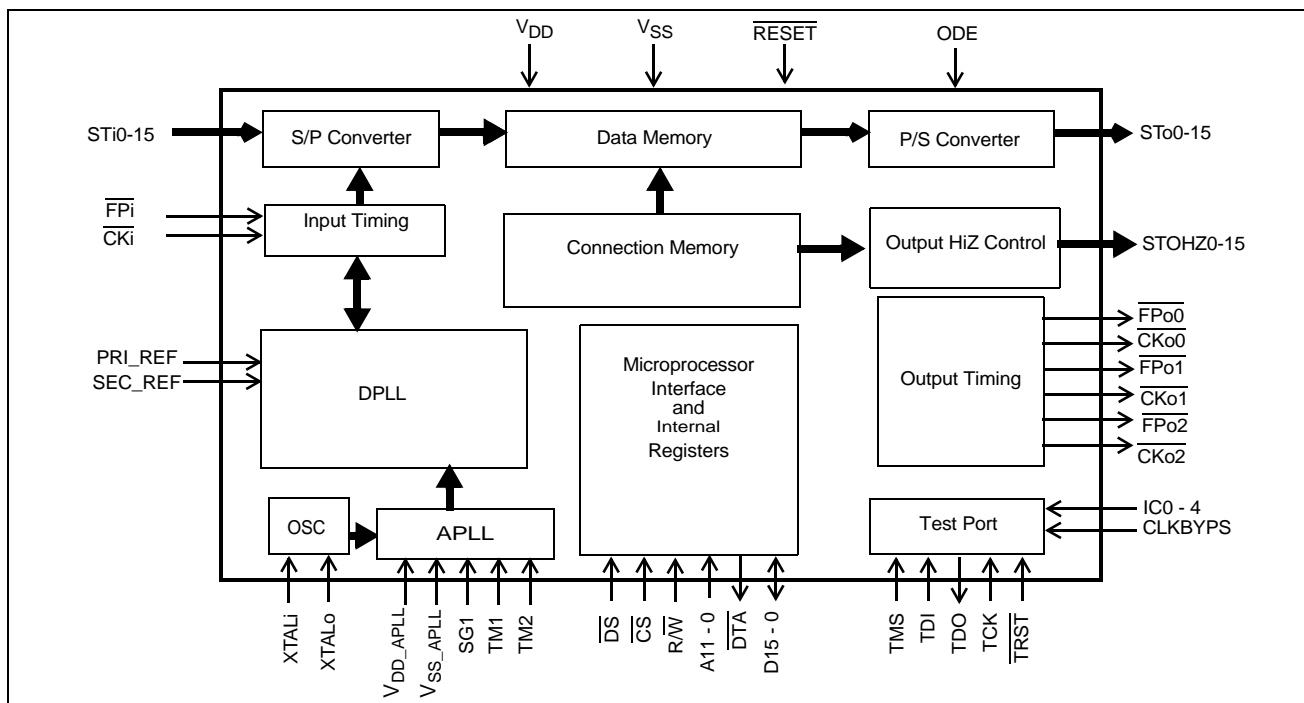

**Figure 1 - ZL50010 Functional Block Diagram**

**Zarlink Semiconductor US Patent No. 5,602,884, UK Patent No. 0772912,  
 France Brevete S.G.D.G. 0772912; Germany DBP No. 69502724.7-08**

## Applications

- Small and medium digital switching platforms
- Access Servers
- Time Division Multiplexers
- Computer Telephony Integration
- Digital Loop Carriers

## Description

The device has 16 ST-BUS inputs (STi0-15) and 16 ST-BUS outputs (STo0-15). It is a non-blocking digital switch with 512 64 kbps channels and performs rate conversion between the ST-BUS inputs and ST-BUS outputs. The ST-BUS inputs accept serial input data streams with the data rate of 2.048 Mbps, 4.096 Mbps or 8.192 Mbps on a per-stream basis. The ST-BUS outputs deliver serial output data streams with the data rate of 2.048 Mbps, 4.096 Mbps or 8.192 Mbps on a per-stream basis. The device also provides 16 high impedance control outputs (STOHZ 0-15) to support the use of external high impedance control buffers.

The ZL50010 has features that are programmable on a per-stream or per-channel basis including message mode, input bit delay, output bit advancement, constant throughput delay and high impedance output control.

The on-chip DPLL meets Telcordia GR-1244-CORE Stratum 4 enhanced specifications (Stratum 4E). It accepts two dedicated timing reference inputs at either 8 kHz, 1.544 MHz or 2.048 MHz. Alternatively, one reference can be replaced by an internal 8 kHz signal derived from the ST-BUS input frame boundary. The DPLL provides automatic reference switching, jitter attenuation, holdover and free run functions. It can be used as a system's ST-BUS timing source which is synchronized to the network. The DPLL can also be bypassed so that the device operates under system timing.

## Table of Contents

<b>Features</b> .....	<b>1</b>
<b>Applications</b> .....	<b>2</b>
<b>Description</b> .....	<b>2</b>
<b>1.0 Device Overview</b> .....	<b>15</b>
<b>2.0 Functional Description</b> .....	<b>15</b>
2.1 ST-BUS Input Data Rate and Input Timing .....	15
2.1.1 ST-BUS Input Operation Mode .....	15
2.1.2 Frame Pulse Input and Clock Input Timing .....	15
2.1.3 ST-BUS Input Timing .....	17
2.2 ST-BUS Output Data Rate and Output Timing .....	18
2.2.1 ST-BUS Output Operation Mode .....	18
2.2.2 Frame Pulse Output and Clock Output Timing .....	18
2.2.3 ST-BUS Output Timing .....	21
2.3 Serial Data Input Delay and Serial Data Output Offset .....	22
2.3.1 Input Channel Delay Programming .....	22
2.3.2 Input Bit Delay Programming .....	22
2.3.3 Fractional Input Bit Delay Programming .....	23
2.3.4 Output Channel Delay Programming .....	23
2.3.5 Output Bit Delay Programming .....	24
2.3.6 Fractional Output Bit Advancement Programming .....	24
2.3.7 External High Impedance Control, STOZH 0 to 15 .....	25
2.4 Data Delay Through The Switching Paths .....	26
2.5 Connection Memory Description .....	28
2.5.1 Connection Memory Block Programming .....	28
2.6 Bit Error Rate (BER) Test .....	29
2.7 Quadrant frame programming .....	30
2.8 Microprocessor Port .....	31
2.9 Digital Phase-Locked Loop (DPLL) Operation .....	31
2.9.1 DPLL Master Mode .....	32
2.9.1.1 Master Mode Reference Inputs .....	32
2.9.1.2 Master Mode Reference Switching .....	33
2.9.1.3 DPLL Status Reporting .....	33
2.9.1.4 Master Mode Output Offset Adjustment .....	33
2.9.2 DPLL Freerun Mode .....	34
2.9.3 DPLL Bypass Mode .....	34
2.10 DPLL Functional Description .....	35
2.10.1 CKi/FPi Synchronizer and PRI_REF Select Mux Circuits .....	35
2.10.2 Reference Select and Frequency Mode Mux Circuits .....	36
2.10.3 Skew Control Circuit .....	36
2.10.4 Reference Monitor Circuit .....	36
2.10.5 LOS Control Circuit .....	37
2.10.6 State Machine Circuit .....	37
2.10.7 Maximum Time Interval Error (MTIE) Circuit .....	38
2.10.8 Phase-Locked Loop (PLL) Circuit .....	38
2.11 DPLL Performance .....	40
2.11.1 Intrinsic Jitter .....	40
2.11.2 Jitter Tolerance .....	40
2.11.3 Jitter Transfer .....	40
2.11.4 Frequency Accuracy .....	40
2.11.5 Holdover Accuracy .....	42
2.11.6 Locking Range .....	42
2.11.7 Phase Slope .....	42

---

## Table of Contents

2.11.8 MTIE. . . . .	42
2.11.9 Phase Lock Time . . . . .	43
2.12 Alignment Between Input and Output Frame Pulses. . . . .	43
<b>3.0 Oscillator Requirements . . . . .</b>	<b>44</b>
3.1 External Crystal Oscillator . . . . .	44
3.2 External Clock Oscillator . . . . .	45
<b>4.0 Device Reset and Initialization . . . . .</b>	<b>46</b>
<b>5.0 JTAG Support. . . . .</b>	<b>46</b>
5.1 Test Access Port (TAP) . . . . .	46
5.2 Instruction Register . . . . .	47
5.3 Test Data Register. . . . .	47
5.4 BSDL . . . . .	47
<b>6.0 Register Address Mapping . . . . .</b>	<b>48</b>
<b>7.0 Detail Register description . . . . .</b>	<b>50</b>
<b>8.0 Memory Address Mappings . . . . .</b>	<b>68</b>
<b>9.0 Connection Memory Bit Assignment . . . . .</b>	<b>69</b>

## List of Figures

Figure 1 - ZL50010 Functional Block Diagram	1
Figure 2 - 24 mm x 24 mm LQFP (JEDEC MS-026) Pinout Diagram	8
Figure 3 - 13 mm x 13 mm 144 Ball LPGA Pinout Diagram	9
Figure 4 - Input Timing when (CKIN2 to CKIN0 Bits = 010) in the Control Register	16
Figure 5 - Input Timing when (CKIN2 to CKIN0 Bits = 001) in the Control Register	16
Figure 6 - Input Timing when (CKIN2 to CKIN0 Bits = 000) in the Control Register	16
Figure 7 - ST-BUS Input Timing for Various Input Data Rates	17
Figure 8 - FPo0 and CKo0 Output Timing when the CKFP0 Bit = 0	19
Figure 9 - FPo0 and CKo0 Output Timing when the CKFP0 Bit = 1	19
Figure 10 - FPo1 and CKo1 Output Timing when the CKFP1 Bit = 0	19
Figure 11 - FPo1 and CKo1 Output Timing when the CKFP1 Bit = 1	19
Figure 12 - FPo2 and CKo2 Output Timing when the CKFP2 Bit = 0	20
Figure 13 - FPo2 and CKo2 Output Timing when the CKFP2 Bit = 1	20
Figure 14 - ST-BUS Output Timing for Various Output Data Rates	21
Figure 15 - Input Channel Delay Timing Diagram	22
Figure 16 - Input Bit Delay Timing Diagram	23
Figure 17 - Output Channel Delay Timing Diagram	23
Figure 18 - Output Bit Delay Timing Diagram	24
Figure 19 - Fractional Output Bit Advancement Timing Diagram	24
Figure 20 - Example: External High Impedance Control Timing	25
Figure 21 - Data Throughput Delay when Input and Output Channel Delay are Disabled for Input Ch0 Switched to Output Ch0	27
Figure 22 - Data Throughput Delay when Input Channel Delay is Enabled and Output Channel Delay is Disabled for Input Ch0 Switched to Output Ch0	27
Figure 23 - Data Throughput Delay when Input Channel Delay is Disabled and Output Channel Delay is Enabled for Input Ch0 Switch to Output Ch0	27
Figure 24 - Data Throughput Delay when Input and Output Channel Delay are Enabled for Input Ch0 Switched to Output Ch0	28
Figure 25 - DPLL Functional Block Diagram	35
Figure 26 - Skew Control Circuit Diagram	36
Figure 27 - State Machine Diagram	37
Figure 28 - Block Diagram of the PLL Module	38
Figure 29 - DPLL Jitter Transfer Function Diagram - Wide Range of Frequencies	41
Figure 30 - Detailed DPLL Jitter Transfer Function Diagram (Wander Transfer Diagram)	41
Figure 31 - Crystal Oscillator Circuit	44
Figure 32 - External Clock Oscillator Circuit	45
Figure 33 - Frame Pulse Input and Clock Input Timing Diagram	72
Figure 34 - Frame Boundary Timing with Input Clock (Cycle-to-Cycle) Variation	72
Figure 35 - Frame Boundary Timing with Input Frame Pulse (Cycle-to-Cycle) Variation	73
Figure 36 - XTALi Input Timing Diagram when Clock Oscillator is Connected	73
Figure 37 - Reference Input Timing Diagram when the Input Frequency = 8 kHz	74
Figure 38 - Reference Input Timing Diagram when the Input Frequency = 2.048 MHz	74
Figure 39 - Reference Input Timing Diagram when the Input Frequency = 1.544 Hz	74
Figure 40 - Input and Output Frame Boundary Offset	75
Figure 41 - FPo0 and CKo0 Timing Diagram	76
Figure 42 - FPo1 and CKo1 Timing Diagram	77
Figure 43 - FPo2 and CKo2 Timing Diagram	78
Figure 44 - ST-BUS Inputs (STi0 - 15) Timing Diagram	79
Figure 45 - ST-BUS Outputs (STo0 - 15) Timing Diagram	80

### List of Figures

Figure 46 - Serial Output and External Control ..... 81  
Figure 47 - Output Driver Enable (ODE) ..... 81  
Figure 48 - Motorola Non-Multiplexed Bus Timing..... 82  
Figure 49 - JTAG Test Port Timing Diagram ..... 83  
Figure 50 - Reset Pin Timing Diagram..... 83

## List of Tables

Table 1 - FPi and CKi Input Programming . . . . .	16
Table 2 - FPo0 and CKo0 Output Programming . . . . .	18
Table 3 - FPo1 and CKo1 Output Programming . . . . .	18
Table 4 - FPo2 and CKo2 Output Programming . . . . .	18
Table 5 - Variable Range for Input Streams . . . . .	26
Table 6 - Variable Range for Output Streams . . . . .	26
Table 7 - Data Throughput Delay . . . . .	26
Table 8 - Connection Memory in Block Programming Mode . . . . .	29
Table 9 - Definition of the Four Quadrant Frames . . . . .	30
Table 10 - Quadrant Frame 0 LSB Replacement . . . . .	30
Table 11 - Quadrant Frame 1 LSB Replacement . . . . .	30
Table 12 - Quadrant Frame 2 LSB Replacement . . . . .	30
Table 13 - Quadrant Frame 3 LSB Replacement . . . . .	31
Table 14 - DPLL Operating Mode Settings . . . . .	32
Table 15 - LOS Outputs in the Failure Detect Modes . . . . .	37
Table 16 - Address Map for Device Specific Registers . . . . .	49
Table 17 - Control Register (CR) Bits . . . . .	50
Table 18 - Internal Mode Selection (IMS) Register Bits . . . . .	52
Table 19 - BER Start Receiving Register (BSRR) Bits . . . . .	53
Table 20 - BER Length Register (BLR) Bits . . . . .	54
Table 21 - BER Count Register (BCR) Bits . . . . .	54
Table 22 - DPLL Operation Mode (DOM) Register Bits . . . . .	55
Table 23 - DPLL Output Adjustment (DPOA) Register Bits . . . . .	57
Table 24 - DPLL House Keeping (DHKR) Register Bits . . . . .	57
Table 25 - Stream Input Control Register 0 to 7 (SICR0 to SICR7) . . . . .	58
Table 26 - Stream Input Control Register 8 to 15 (SICR8 to SICR15) . . . . .	60
Table 27 - Stream Input Delay Register 0 to 7 (SIDR0 to SIDR7) . . . . .	62
Table 28 - Stream Input Delay Register 8 to 15 (SIDR8 to SIDR15) . . . . .	63
Table 29 - Stream Output Control Register 0 to 7 (SOCR0 to SOCR7) . . . . .	64
Table 30 - Stream Output Control Register 8 to 15 (SOCR8 to SOCR15) . . . . .	65
Table 31 - Stream Output Offset Register 0 to 7 (SOOR0 to SOOR7) . . . . .	66
Table 32 - Stream Output Offset Register 8 to 15 (SOOR8 to SOOR15) . . . . .	67
Table 33 - Address Map for Memory Locations (512x512 DX, MSB of address = 1) . . . . .	68
Table 34 - Connection Memory Bit Assignment when the CMM bit = 0 . . . . .	69
Table 35 - Connection Memory Bits Assignment when the CMM bit = 1 . . . . .	69

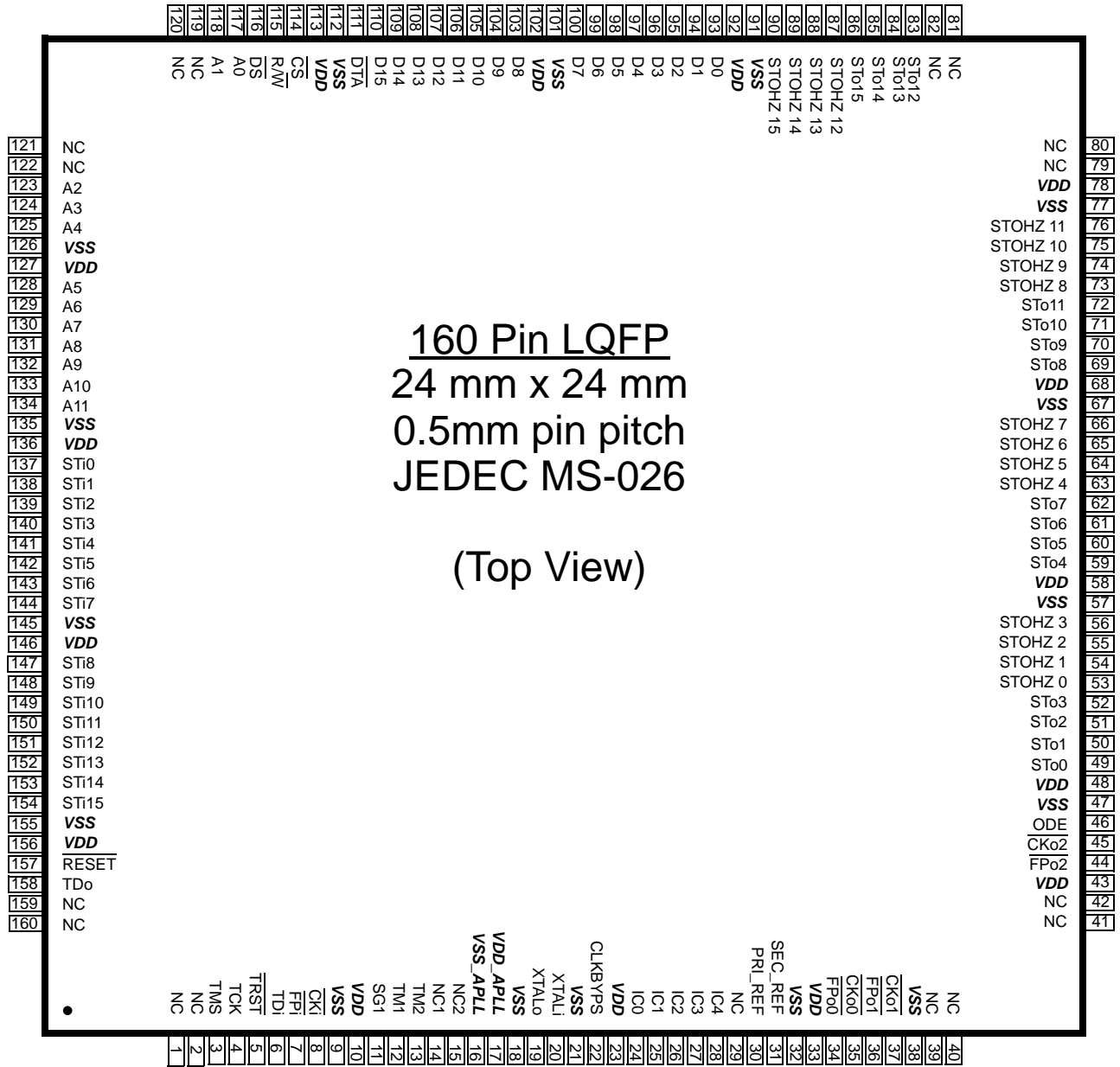

Figure 2 - 24 mm x 24 mm LQFP (JEDEC MS-026) Pinout Diagram



**PINOUT DIAGRAM:** (as viewed through top of package)

A1 corner identified by metallized marking, mould indent, ink dot or right-angled corner

	1	2	3	4	5	6	7	8	9	10	11	12
A	ODE	FPo2	FPo0	SEC_ REF	IC1	IC0	XTALi	XTALo	TM1	CKi	TDi	TCK
B	CKo2	CKo1	FPo1	CKo0	IC3	IC2	CLK BYPS	VDD_ APLL	SG1	FPi	TRST	TMS
C	STo2	STo1	STOHZ 0	PRI_ REF	NC	NC	IC4	NC2	NC1	TM2	TDo	STi15
D	STo3	STo0	STOHZ 1	VSS	VDD	VDD	VDD	VSS_ APLL	VSS	STi8	RESET	STi14
E	STo5	STo4	STOHZ 3	STOHZ 2	VSS	VSS	VSS	VSS	VDD	STi9	STi13	STi12
F	STo6	STo7	STOHZ 4	VDD	VSS	VSS	VSS	VSS	VDD	STi7	STi10	STi11
G	STOHZ 6	STOHZ 7	STOHZ 5	VDD	VSS	VSS	VSS	VSS	STi1	STi6	STi5	STi4
H	STo9	STo10	STo8	VDD	VSS	VSS	VSS	VSS	STi0	DS	STi2	STi3
J	STo11	STOHZ 11	STOHZ 8	VSS	D2	VDD	VDD	VDD	A10	A9	A8	A11
K	STOHZ 9	STOHZ 15	STo15	STOHZ 13	D1	D5	CS	D10	D11	A5	A4	A7
L	STOHZ 10	STo12	STo13	D3	D15	D4	D7	D12	D14	A2	A3	A6
M	STo14	STOHZ 12	STOHZ 14	D0	DTA	D6	D8	D9	D13	A0	A1	R/W

**Figure 3 - 13 mm x 13 mm 144 Ball LBGGA Pinout Diagram**

## Pin Description

LQFP Pin Number	LBGA Ball Number	Name	Description
10, 23, 33, 43, 48, 58, 68, 78, 92, 102, 113, 127, 136, 146, 156	D5, D6, D7 E9 F4, F9 G4 H4 J6, J7, J8	$V_{DD}$	<b>Power Supply for the device: +3.3 V</b>
9, 18, 21, 32, 38, 47, 57, 67, 77, 91, 101, 112, 126, 135, 145, 155	D4, D9 E5, E6, E7, E8 F5, F6, F7, F8 G5, G6, G7, G8 H5, H6, H7, H8 J4	$V_{SS}$ (GND)	<b>Ground.</b>
3	B12	TMS	<b>Test Mode Select (3.3 V Tolerant Input with internal pull-up):</b> JTAG signal that controls the state transitions of the TAP controller. This pin is pulled high by an internal pull-up resistor when it is not driven.
4	A12	TCK	<b>Test Clock (5 V Tolerant Input):</b> Provides the clock to the JTAG test logic.
5	B11	$\overline{TRST}$	<b>Test Reset (3.3 V Tolerant Input with internal pull-up):</b> Asynchronously initializes the JTAG TAP controller by putting it in the Test-Logic-Reset state. This pin should be pulsed low during power-up to ensure that the device is in the normal functional mode. When JTAG is not being used, this pin should be pulled low during normal operation.
6	A11	TDi	<b>Test Serial Data In (3.3 V Tolerant Input with internal pull-up):</b> JTAG serial test instructions and data are shifted in on this pin. This pin is pulled high by an internal pull-up resistor when it is not driven.
7	B10	$\overline{FPI}$	<b>ST-BUS Frame Pulse Input (5 V Tolerant Input):</b> This pin accepts the frame pulse which stays low for 61 ns, 122 ns or 244 ns at the frame boundary. The frame pulse associating with the highest input data rate has to be applied to this pin. The frame pulse frequency is 8 kHz. The device also accepts positive frame pulse if the FPINP bit is high in the Internal Mode Selection register.
8	A10	$\overline{CKI}$	<b>ST-BUS Clock Input (5 V Tolerant Input):</b> This pin accepts an 4.096 MHz, 8.192 MHz or 16.384 MHz clock. The input clock frequency has to be equal to or greater than twice of the highest input data rate. The clock falling edge defines the input frame boundary. The device also allows the clock rising edge to define the frame boundary by programming the CKINP bit in the Internal Mode Selection register.
11	B9	SG1	<b>APLL Test Control (3.3 V Input with internal pull-down):</b> For normal operation, this input MUST be low.

## Pin Description (continued)

LQFP Pin Number	LBGA Ball Number	Name	Description
12	A9	TM1	<b>APLL Test Pin 1:</b> For normal operation, this input MUST be low.
13	C10	TM2	<b>APLL Test Pin 2:</b> For normal operation, this input MUST be low.
14, 15	C9, C8	NC1, NC2	<b>No Connection:</b> These pins MUST be left unconnected.
16	D8	V <sub>SS</sub> _APLL	<b>Ground for the APLL Circuit.</b>
17	B8	V <sub>DD</sub> _APLL	<b>Power Supply for the on-chip Analog Phase-Locked Loop (APLL) Circuit:</b> +3.3 V
19	A8	XTALo	<b>Oscillator Clock Output (3.3 V Output).</b> This pin is connected to a 20 MHz crystal (see Figure 31 on page 44), or it is left unconnected if a clock oscillator is connected to the XTALi pin (see Figure 32 on page 45). If the device is to be used in DPLL Bypass mode only, the crystal or clock oscillator can be omitted, in which case this pin must be left unconnected.
20	A7	XTALi	<b>Oscillator Clock Input (3.3 V Input).</b> This pin is connected to a 20 MHz crystal (see Figure 31 on page 44), or it is connected to a clock oscillator (see Figure 32 on page 45). If the device is to be used in DPLL Bypass mode only, the crystal or clock oscillator can be omitted, in which case this pin must be held low.
22	B7	CLKBYP	<b>Test Clock Input:</b> For device testing only, in normal operation, this input MUST be low.
24 - 28	A6, A5, B6, B5, C7	IC0 - 4	<b>Internal connection (3.3 V Tolerant Inputs with internal pull-down):</b> In normal mode, these pins must be low.
30	C4	PRI_REF	<b>Primary Reference Input (5 V Tolerant Input):</b> This pin accepts an 8 kHz, 1.544 MHz or 2.048 MHz timing reference. It is used as one of the primary references for the DPLL in the Master mode. This pin is ignored in the DPLL Freerun or Bypass Mode. When this pin is not in use, it is required to be driven high or low by connecting it to V <sub>DD</sub> or ground through an external pull-up resistor or external pull-down resistor.
31	A4	SEC_REF	<b>Secondary Reference Input (5 V Tolerant Inputs):</b> This pins accept an 8 kHz, 1.544 MHz or 2.048 MHz timing reference. It is used as the secondary reference for the DPLL in the Master mode. This pin is ignored in the DPLL Freerun or Bypass Mode. When this pin is not in use, it is required to be driven high or low by connecting it to V <sub>DD</sub> ground, through an external pull-up resistor or external pull-down resistor.

## Pin Description (continued)

LQFP Pin Number	LBGA Ball Number	Name	Description
34	A3	$\overline{\text{FPo0}}$	<b>ST-BUS Frame Pulse Output 0 (5 V Tolerance Three-state Output):</b> ST-BUS frame pulse output which stays low for 244 ns or 122 ns at the output frame boundary. Its frequency is 8 kHz. The polarity of this signal can be changed using the Internal Mode Selection register.
35	B4	$\overline{\text{CKo0}}$	<b>ST-BUS Clock Output 0 (5 V Tolerant Three-state Output):</b> A 4.094 MHz or 8.192 MHz clock output. The clock falling edge defines the output frame boundary. The polarity of this signal can be changed using the Internal Mode Selection register.
36	B3	$\overline{\text{FPo1}}$	<b>ST-BUS Frame Pulse Output 1 (5 V Tolerant Three-state Output):</b> ST-BUS frame pulse output which stays low for 61 ns or 122 ns at the output frame boundary. Its frequency is 8 kHz. The polarity of this signal can be changed using the Internal Mode Selection register.
37	B2	$\overline{\text{CKo1}}$	<b>ST-BUS Clock Output 1 (5 V Tolerant Three-state Output):</b> A 16.384 MHz or 8.192 MHz clock output. The clock falling edge defines the output frame boundary. The polarity of this signal can be changed using the Internal Mode Selection register.
44	A2	$\overline{\text{FPo2}}$	<b>ST-BUS Frame Pulse Output 2 (5 V Tolerant High Speed Three-state Output):</b> ST-BUS frame pulse output which stays low for 30 ns or 61 ns at the frame boundary. Its frequency is 8 kHz. The polarity of this signal can be changed using the Internal Mode Selection register.
45	B1	$\overline{\text{CKo2}}$	<b>ST-BUS Clock Output 2 (5 V Tolerant High Speed Three-state Output):</b> A 32.768 MHz or 16.384 MHz clock output. The clock falling edge defines the output frame boundary. The polarity of this signal can be changed using the Internal Mode Selection register.
46	A1	ODE	<b>Output Drive Enable (5 V Tolerant Input):</b> This is the asynchronously output enable control for the STo0 - 15 and the output driven high control for the STOHZ 0 - 15 serial outputs. When it is high, the STo0 - 15 and STOHZ 0 - 15 are enabled. When it is low, the STo0 - 15 are in the high impedance state and the STOHZ 0 - 15 are driven high.
49 - 52 59 - 62 69 - 72 83 - 86	D2, C2, C1, D1 E2, E1, F1, F2 H3, H1, H2, J1 L2, L3, M1, K3	STo0 - 3 STo4 - 7 STo8 - 11 STo12 - 15	<b>Serial Output Streams 0 to 15 (5 V Tolerant Three-state Outputs):</b> The data rate of these output streams can be selected independently using the stream control output registers. In the 2.048 Mbps mode, these pins have serial TDM data streams at 2.048 Mbps with 32 channels per stream. In the 4.096 Mbps mode, these pins have serial TDM data streams at 4.096 Mbps with 64 channels per stream. In the 8.192 Mbps mode, these pins have serial TDM data streams at 8.192 Mbps with 128 channels per stream.

## Pin Description (continued)

LQFP Pin Number	LBGA Ball Number	Name	Description
53 - 56 63 - 66 73 - 76 87 - 90	C3, D3, E4, E3 F3, G3, G1, G2 J3, K1, L1, J2 M2, K4, M3, K2	STOHZ 0 - 3 STOHZ 4 - 7 STOHZ 8 - 11 STOHZ 12 - 15	<b>Serial Output Streams High Impedance Control 0 to 15 (5 V Tolerant Three-state Outputs):</b> These pins are used to enable (or disable) external three-state buffers. When an output channel is in the high impedance state, the STOHZ drives high for the duration of the corresponding output channel. When the STo channel is active, the STOHZ drives low for the duration of the corresponding output channel.
93 - 96 97 - 100 103 - 106 107 - 110	M4, K5, J5, L4 L6, K6, M6, L7 M7, M8, K8, K9 L8, M9, L9, L5	D0 - D3 D4 - D7 D8 - D11 D12 - D15	<b>Data Bus 0 - 15 (5 V Tolerant I/Os):</b> These pins form the 16 bit data bus of the microprocessor port.
111	M5	$\overline{DTA}$	<b>Data Transfer Acknowledgment (5 V Tolerant Three-state Output):</b> This active low output indicates that a data bus transfer is complete. A pull-up resistor is required to hold this pin at HIGH level.
114	K7	$\overline{CS}$	<b>Chip Select (5 V Tolerant Input):</b> Active low input used by the microprocessor to enable the microprocessor port access.
115	M12	$R/\overline{W}$	<b>Read/Write (5 V Tolerant Input):</b> This input controls the direction of the data bus lines (D0-D15) during a microprocessor access.
116	H10	$\overline{DS}$	<b>Data Strobe (5 V Tolerant Input):</b> This active low input works in conjunction with CS to enable the microprocessor port read and write operations.
117, 118 123 - 125 128 - 130 131 - 134	M10, M11 L10, L11, K11 K10, L12, K12 J11, J10, J9, J12	A0 - A1 A2 - A4 A5 - A7 A8 - A11	<b>Address 0 - 11 (5 V Tolerant Inputs):</b> These pins form the 12 bit address bus to the internal memories and registers.
137 - 139 140 - 142 143, 144 147 - 149 150 - 152 153, 154	H9, G9, H11 H12, G12, G11 G10, F10 D10, E10, F11 F12, E12, E11 D12, C12	STi0 - 2 STi3 - 5 STi6 - 7 STi8 - 10 STi11 - 13 STi14 - 15	<b>Serial Input Streams 0 to 15 (5 V Tolerant Inputs):</b> The data rate of these input streams can be selected independently using the stream input control registers. In the 2.048 Mbps mode, these pins accept serial TDM data streams at 2.048 Mbps with 32 channels per stream. In the 4.096 Mbps mode, these pins accept serial TDM data streams at 4.096 Mbps with 64 channels per stream. In the 8.192 Mbps mode, these pins accept serial TDM data streams at 8.192 Mbps with 128 channels per stream. Unused serial input pins are required to connect to either Vdd or ground, through an external pull-up resistor or external pull-down resistors.

**Pin Description (continued)**

LQFP Pin Number	LBGA Ball Number	Name	Description
157	D11	$\overline{\text{RESET}}$	<b>Device Reset (5 V Tolerant Input):</b> This input (active LOW) puts the device in its reset state that disables the ST0 - 15 drivers and drives the STOHZ 0 - 15 outputs to high. It also clears the device registers and internal counters. To ensure proper reset action, the reset pin must be low for longer than 1 ms. Upon releasing the reset signal to the device, the first microprocessor access can take place after 600 $\mu\text{s}$ due to the time required to stabilize the APLL and crystal oscillator blocks from the power down state.
158	C11	TDo	<b>Test Serial Data Out (3 V Tolerant Three-state Output):</b> JTAG serial data is output on this pin on the falling edge of TCK. This pin is held in high impedance state when JTAG is not enabled.
1, 2, 29, 39 - 42, 79 - 82, 119 - 122, 159, 160	C5, C6	NC	<b>No Connection Pins.</b> These pins are not connected to the device internally.

## 1.0 Device Overview

The device uses the ST-BUS input frame pulse and the ST-BUS input clock to define the input frame boundary and timing for the ST-BUS input streams with various data rates (2.048 Mbps, 4.096 Mbps and/or 8.192 Mbps). The output frame boundary is defined by the output frame pulses and the output clock timing for the ST-BUS output streams with various data rates (2.048 Mbps, 4.096 Mbps and/or 8.192 Mbps).

By using Zarlink's message mode capability, microprocessor data can be broadcast to the data output streams on a per channel basis. This feature is useful for transferring control and status information for external circuits or other ST-BUS devices.

The on-chip DPLL can be operated in one of three modes: Master, Freerun or Bypass. In Master mode, the DPLL can be used as a system's timing source to provide ST-BUS clocks and frame pulses which are synchronized to the network. In Freerun mode, the DPLL can be used to provide system ST-BUS timing which is independent of the network. In Bypass mode, the DPLL is completely bypassed and the device operates entirely from system timing provided by the input ST-BUS clock and frame pulse. An external 20.000 MHz crystal or clock oscillator is required in Master and Freerun modes. The DPLL intrinsic jitter is 6.25 ns peak to peak.

In Master mode, the DPLL is synchronized to either the PRI\_REF input, the SEC\_REF input, or to an internal 8 kHz signal derived from the input ST-BUS clock and frame pulse. The PRI\_REF and SEC\_REF inputs accept 8 kHz, 1.544 MHz or 2.048 MHz network timing reference signals. The DPLL also provides reference monitoring, automatic bit-error-free reference switching, jitter attenuation and holdover functions. The DPLL output is an internal high speed clock from which output ST-BUS clock and frame pulses are generated.

A non-multiplexed microprocessor port allows users to program the device with various operating modes and switching configurations. Users can use the microprocessor port to perform register read/write, connection memory read/write and data memory read operations. The microprocessor port has a 12 bit address bus, a 16 bit data bus and four control signals.

The device also supports the mandatory requirements of the IEEE-1149.1 (JTAG) standard via the test port.

## 2.0 Functional Description

A functional block diagram of the ZL50010 is shown in Figure 1 on page 1.

### 2.1 ST-BUS Input Data Rate and Input Timing

The device has 16 ST-BUS serial data inputs. Any of the 16 inputs can be programmed to accept different data rates, 2.048 Mbps, 4.096 Mbps or 8.192 Mbps.

#### 2.1.1 ST-BUS Input Operation Mode

Any ST-BUS input can be programmed to accept the 2.048 Mbps, 4.096 Mbps or 8.192 Mbps data using Bit 0 to 2 in the stream input control registers, SICR0 to SICR15 as shown in Table 25 on page 58 and Table 26 on page 60.

The maximum number of input channels is 512 channels. External pull-up or pull-down resistors are required for any unused ST-BUS inputs.

#### 2.1.2 Frame Pulse Input and Clock Input Timing

The frame pulse input  $\overline{FP}_i$  accepts the frame pulse used for the **highest** input data rate. The frame pulse is an 8 kHz input signal which stays low for 244 ns, 122 ns or 61 ns for the input data rate of 2.048 Mbps, 4.096 Mbps or 8.192 Mbps respectively. The frequency of  $\overline{CK}_i$  must be twice the highest data rate. For example, if users present the ZL50010 with 2.048 Mbps and 8.192 Mbps input data, the device should be programmed to accept the input clock of 16.384 MHz and the frame pulse which stays low for 61 ns.

Users have to program the CKIN2 - 0 bits in the Control Register (CR), for the width of the frame pulse low cycle and the frequency of the input clock. See Table 1 for the programming of the CKIN0, CKIN1 and CKIN2 bits in the Control Register.

CKIN2 - 0 bits	F <sub>Pi</sub> Low Cycle	CK <sub>i</sub>	Highest Input Data Rate
000	61 ns	16.384 MHz	8.192 Mbps
001	122 ns	8.192 MHz	4.096 Mbps
010	244 ns	4.096 MHz	2.048 Mbps
011 - 111	Reserved		

**Table 1 - F<sub>Pi</sub> and CK<sub>i</sub> Input Programming**

The device also accepts positive or negative input frame pulse and ST-BUS input clock formats via the programming of the FPINP and CKINP bits in the Internal Mode Selection (IMS) register. By default, the device accepts the negative input clock format.

Figure 4, Figure 5 and Figure 6 describe the usage of CKIN2 - 0, FPINP and CKINP in the Internal Mode Selection (IMS) register:

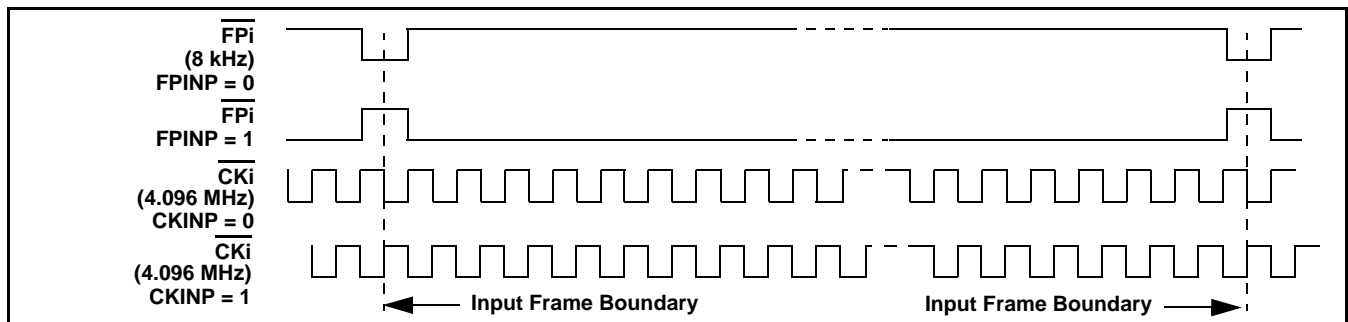

**Figure 4 - Input Timing when (CKIN2 to CKIN0 Bits = 010) in the Control Register**

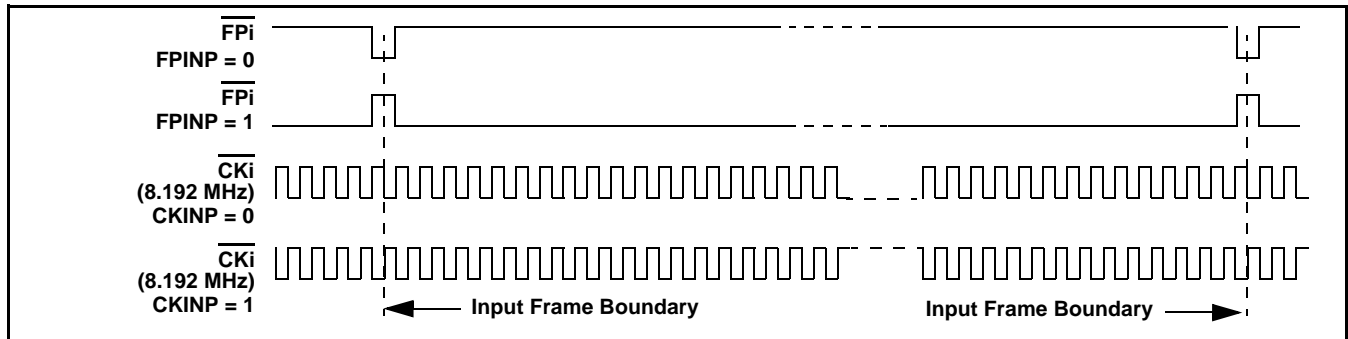

**Figure 5 - Input Timing when (CKIN2 to CKIN0 Bits = 001) in the Control Register**

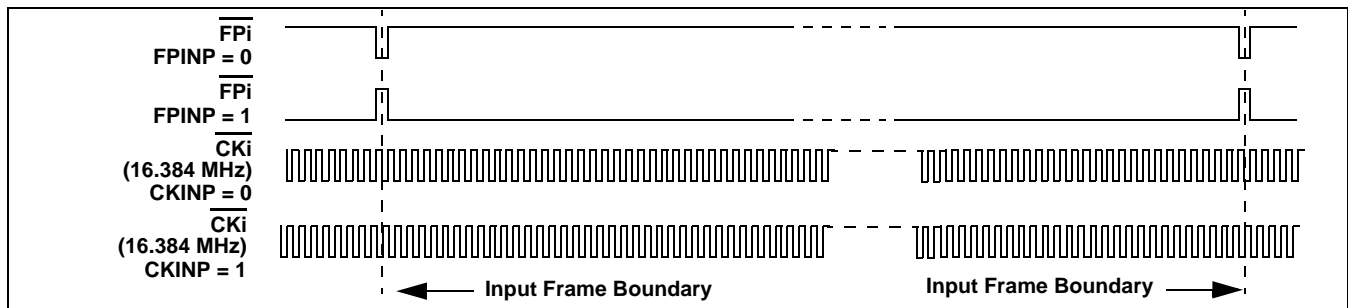

**Figure 6 - Input Timing when (CKIN2 to CKIN0 Bits = 000) in the Control Register**



### 2.1.3 ST-BUS Input Timing

When the negative input frame pulse and negative input clock formats are used, the input frame boundary is defined by the falling edge of the CKi input clock while the FPi is low. When the input data rate is 2.048 Mbps, 4.096 Mbps or 8.192 Mbps, there are 32, 64 or 128 channels per every ST-BUS frame respectively. Figure 7 shows the details:

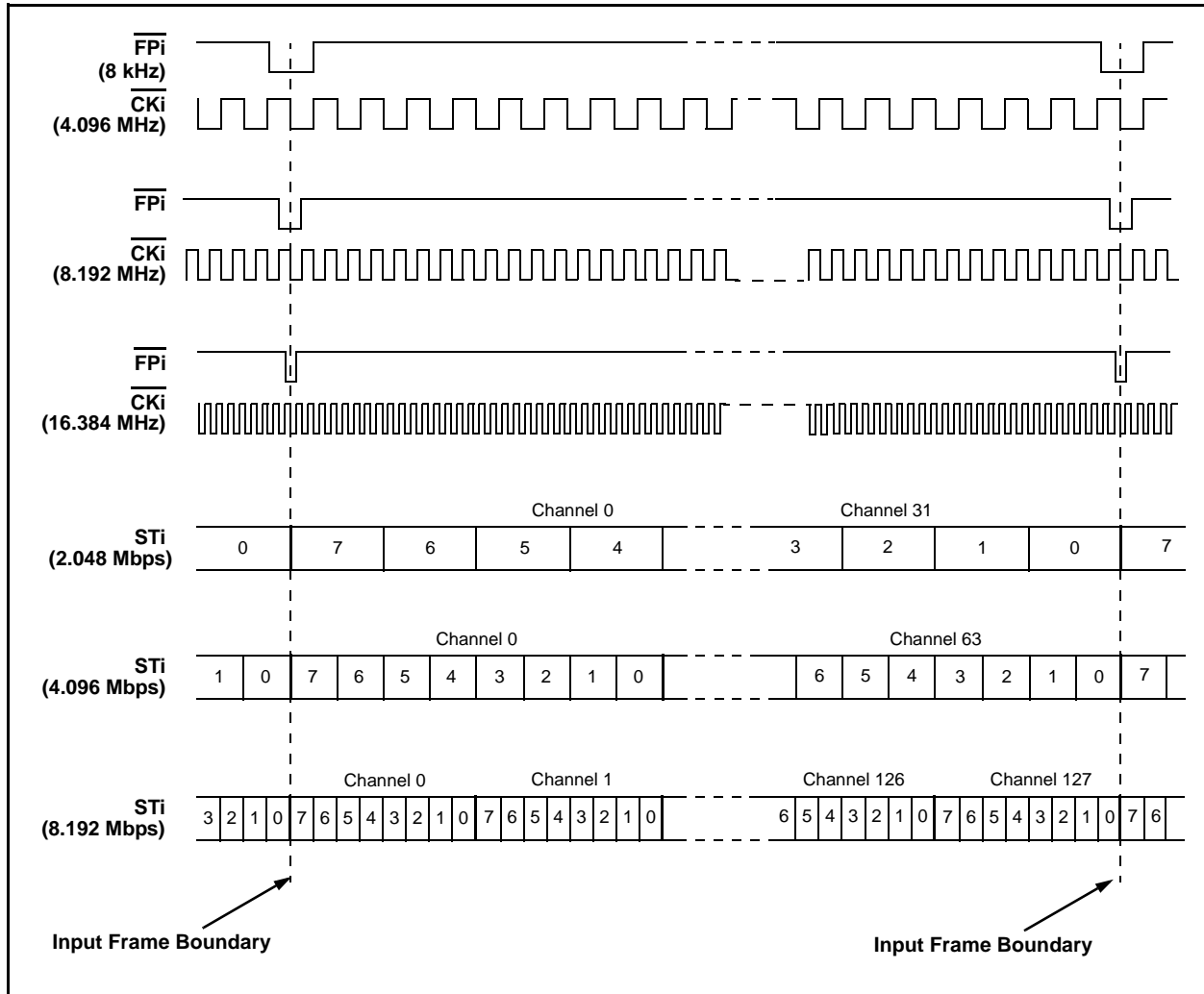

Figure 7 - ST-BUS Input Timing for Various Input Data Rates

## 2.2 ST-BUS Output Data Rate and Output Timing

The device has 16 ST-BUS serial data outputs. Any of the 16 outputs can be programmed to deliver different data rates at 2.048 Mbps, 4.096 Mbps or 8.192 Mbps.

### 2.2.1 ST-BUS Output Operation Mode

Any ST-BUS output can be programmed to deliver the data at 2.048 Mbps, 4.096 Mbps or 8.192 Mbps mode using Bit 0 to 2 in the Stream Output Control Registers, SOCR0 to SOCR15 as shown in Table 29 on page 64 and Table 30 on page 65.

The maximum number of output channels is 512 channels.

### 2.2.2 Frame Pulse Output and Clock Output Timing

The device offers 3 frame pulse outputs,  $\overline{\text{FPo0}}$ ,  $\overline{\text{FPo1}}$  and  $\overline{\text{FPo2}}$ . All output frame pulses are 8 kHz output signals. By default, the output frame boundary is defined by the falling edge of the  $\overline{\text{CKo0}}$ ,  $\overline{\text{CKo1}}$  or  $\overline{\text{CKo2}}$  output clocks while the  $\overline{\text{FPo0}}$ ,  $\overline{\text{FPo1}}$  or  $\overline{\text{FPo2}}$  output frame pulse goes low respectively.

In addition to the default settings, users can also select different output frame pulse low cycles and output clock frequencies by programming the CKFP0, CKFP1 and CKFP2 bits in the Control Register. See Table 2, Table 3 and Table 4 for the bit usage in the Control Register:

CKFP0	$\overline{\text{FPo0}}$ Low Cycle	$\overline{\text{CKo0}}$
0	244 ns	4.096 MHz
1	122 ns	8.192 MHz

Table 2 -  $\overline{\text{FPo0}}$  and  $\overline{\text{CKo0}}$  Output Programming

CKFP1	$\overline{\text{FPo1}}$	$\overline{\text{CKo1}}$
0	61 ns	16.384 MHz
1	122 ns	8.192 MHz

Table 3 -  $\overline{\text{FPo1}}$  and  $\overline{\text{CKo1}}$  Output Programming

CKFP2	$\overline{\text{FPo2}}$	$\overline{\text{CKo2}}$
0	30 ns	32.768 MHz
1	61 ns	16.384 MHz

Table 4 -  $\overline{\text{FPo2}}$  and  $\overline{\text{CKo2}}$  Output Programming

The device also delivers positive or negative output frame pulse and ST-BUS output clock formats via the programming of the FP0P, FP1P, FP2P, CK0P, CK1P and CK2P bits in the Internal Mode Selection (IMS) register. By default, the device delivers the negative output frame pulse and negative output clock formats.

Figure 8 to Figure 13 describe the usage of the CKFP0, CKFP1, CKFP2, FP0P, FP1P, FP2P, CK0P, CK1P and CK2P in the Control Register and Internal Mode Selection Register:

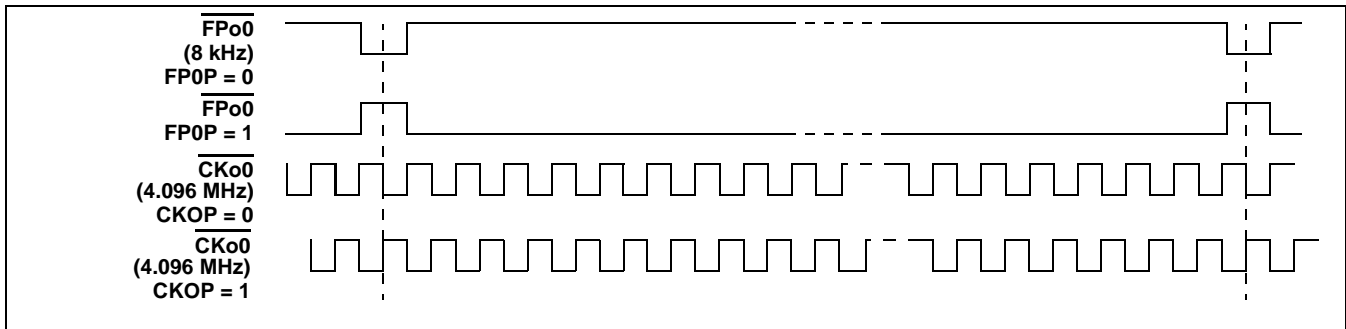

Figure 8 -  $\overline{\text{FPo0}}$  and  $\overline{\text{CKo0}}$  Output Timing when the CKFP0 Bit = 0

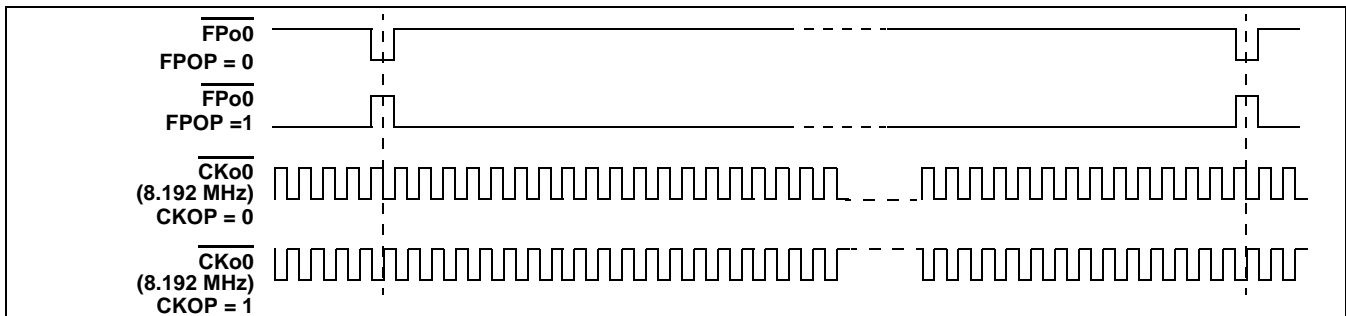

Figure 9 -  $\overline{\text{FPo0}}$  and  $\overline{\text{CKo0}}$  Output Timing when the CKFP0 Bit = 1

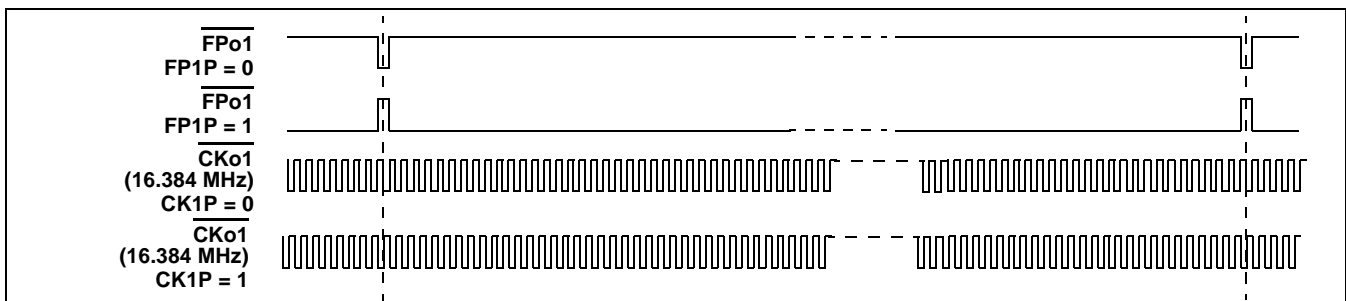

Figure 10 -  $\overline{\text{FPo1}}$  and  $\overline{\text{CKo1}}$  Output Timing when the CKFP1 Bit = 0

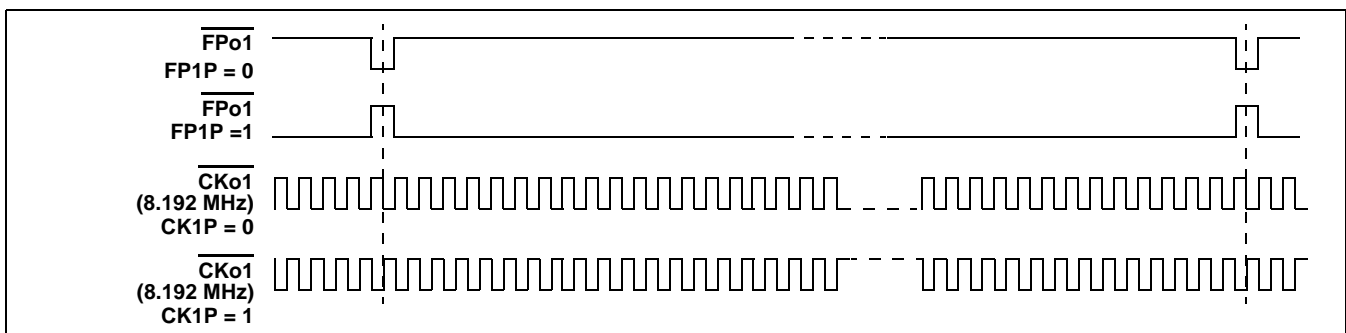

Figure 11 -  $\overline{\text{FPo1}}$  and  $\overline{\text{CKo1}}$  Output Timing when the CKFP1 Bit = 1

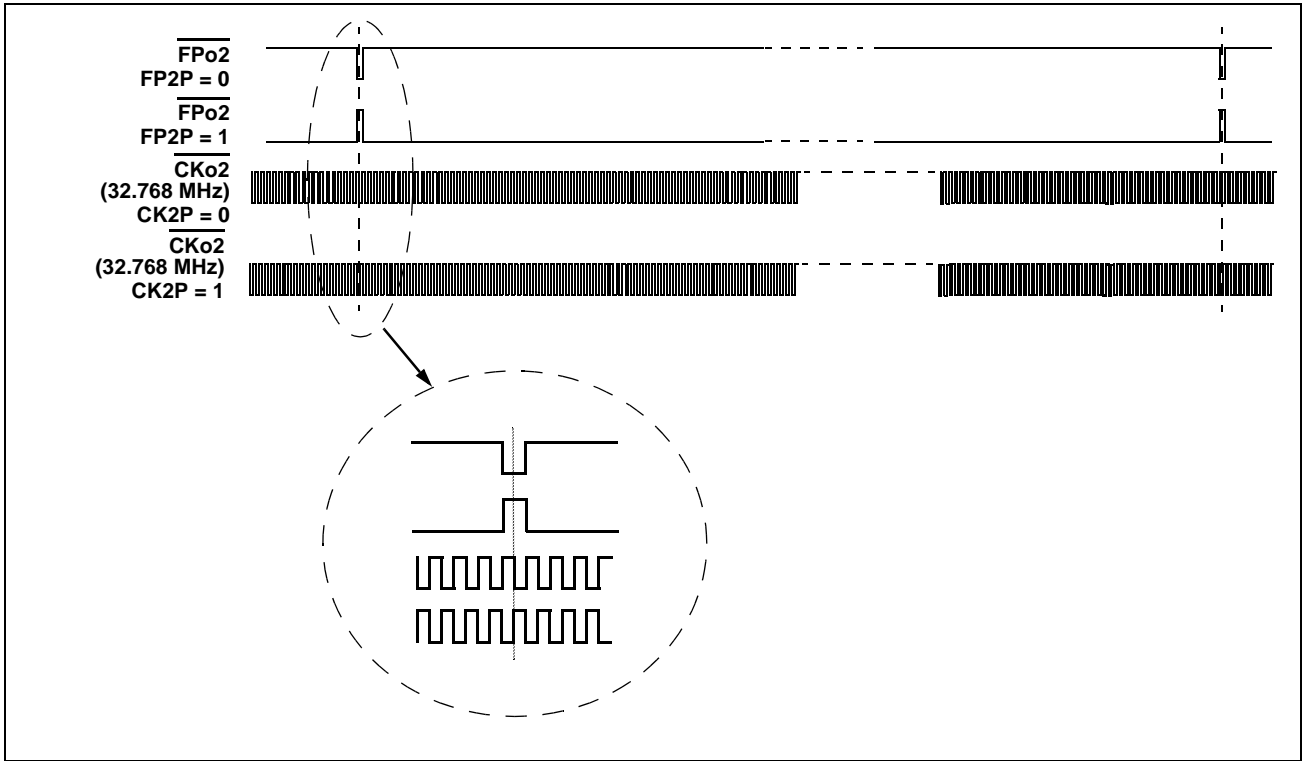

Figure 12 -  $\overline{\text{FPo2}}$  and  $\overline{\text{CKo2}}$  Output Timing when the CKFP2 Bit = 0

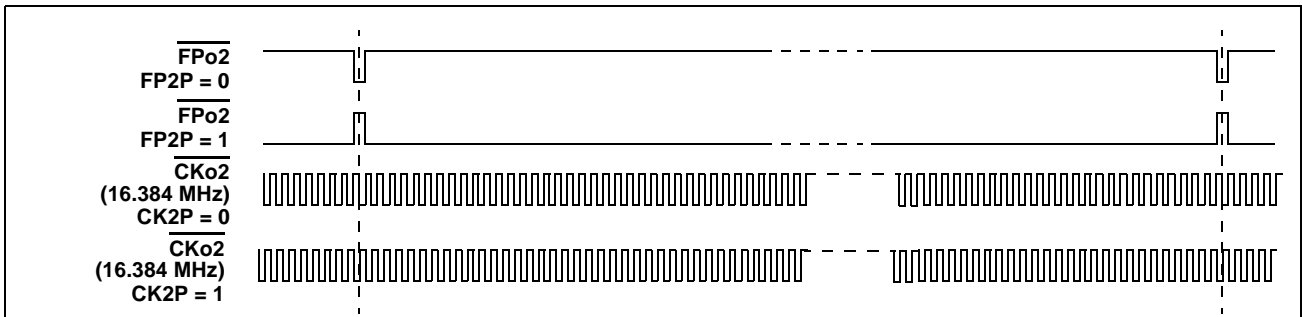

Figure 13 -  $\overline{\text{FPo2}}$  and  $\overline{\text{CKo2}}$  Output Timing when the CKFP2 Bit = 1

### 2.2.3 ST-BUS Output Timing

By default, the output frame boundary is defined by the falling edge of the  $\overline{CKo0}$ ,  $\overline{CKo1}$  or  $\overline{CKo2}$  output clock while the  $\overline{FPo0}$ ,  $\overline{FPo1}$  or  $\overline{FPo2}$  output frame pulse goes low respectively. When the output data rates are 2.048 Mbps, 4.096 Mbps and 8.192 Mbps, there are 32, 64 or 128 output channels per every ST-BUS frame respectively. Figure 14 describes the details.

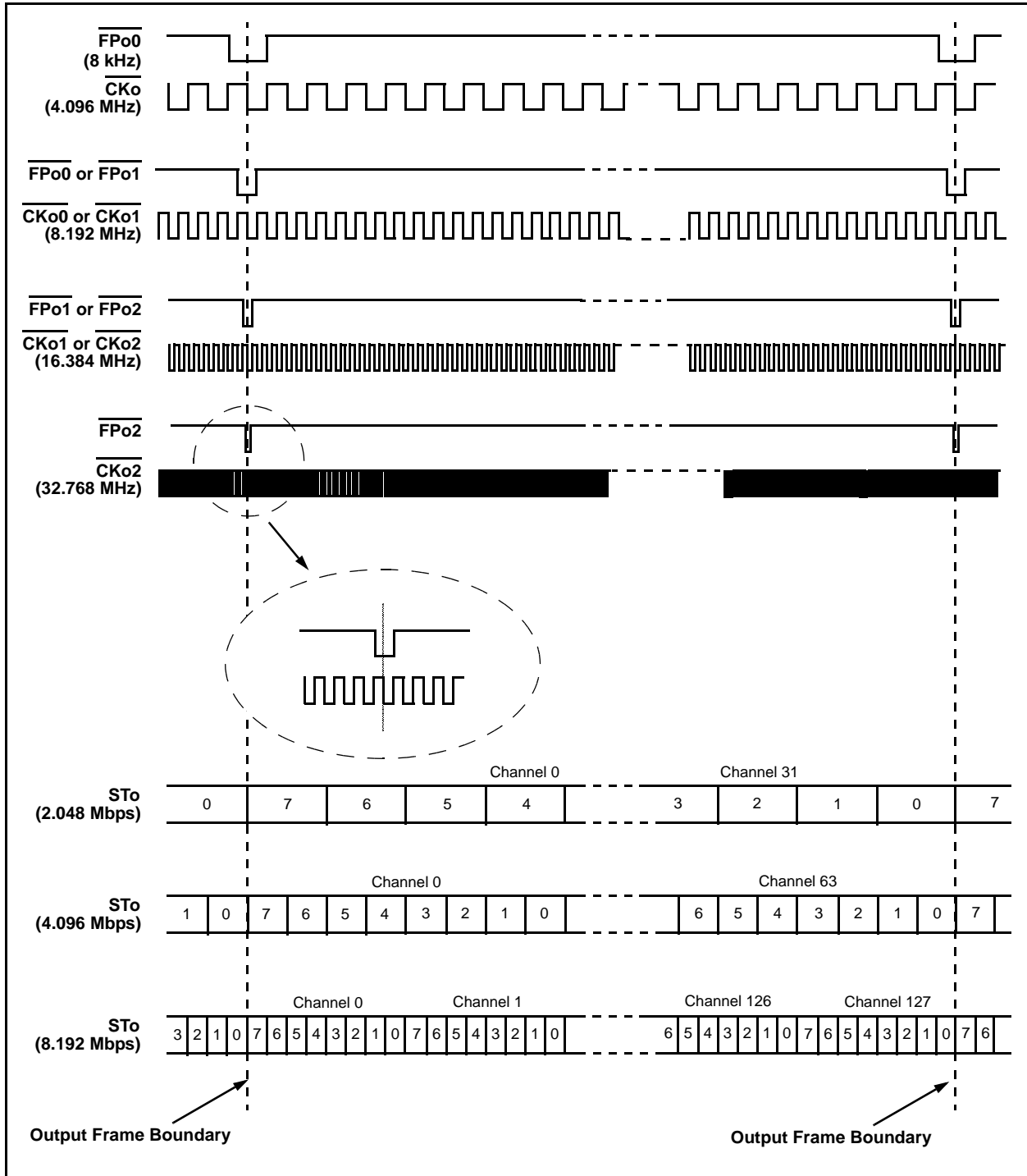

Figure 14 - ST-BUS Output Timing for Various Output Data Rates

### 2.3 Serial Data Input Delay and Serial Data Output Offset

Various registers are provided to adjust the input and output delays for every input and every output data stream. The input and output channel delay can vary from 0 to 31, 0 to 63 and 0 to 127 channel(s) for the 2.048 Mbps, 4.096 Mbps and 8.192 Mbps modes respectively.

The input and output bit delay can vary from 0 to 7 bits. The fractional input bit delay can vary from 1/4, 1/2, 3/4 to 4/4 bit. The fractional output bit advancement can vary from 0, 1/4, 1/2 to 3/4 bit.

#### 2.3.1 Input Channel Delay Programming

This feature allows each input stream to have a different input frame boundary with respect to the input frame boundary defined by the  $\overline{FPI}$  and  $\overline{CKI}$ . By default, all input streams have channel delay of zero such that Ch0 is the first channel that appears after the input frame boundary (see Figure 15).

The input channel delay programming is enabled by setting Bit 3 to 9 in the Stream Input Delay Register (SIDR). The input channel delay can vary from 0 to 31, 0 to 63 and 0 to 127 for the 2.048 Mbps, 4.096 Mbps and 8.192 Mbps modes respectively.

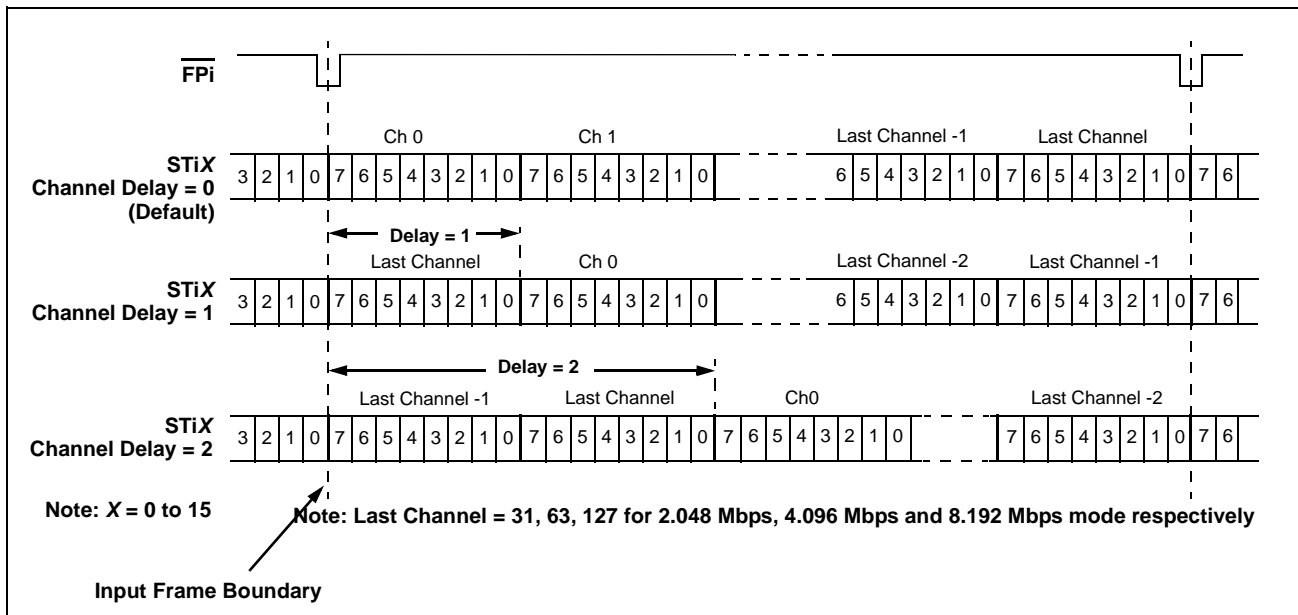

Figure 15 - Input Channel Delay Timing Diagram

#### 2.3.2 Input Bit Delay Programming

In addition to the input channel delay programming, the input bit delay programming feature provides users with more flexibility when designing the switch matrices at high speed, in which the delay lines are easily created on PCM highways which are connected to the switch matrix cards.

By default, all input streams have zero bit delay such that Bit 7 is the first bit that appears after the input frame boundary, see Figure 16 on page 23. The input delay is enabled by Bit 0 to 2 in the Stream Input Delay Registers (SIDR). The input bit delay can vary from 0 to 7 bits.

### 2.3.3 Fractional Input Bit Delay Programming

In addition to the input bit delay feature, the device allows users to change the sampling point of the input bit. By default, the sampling point is at 3/4 bit. Users can change the sampling point to 1/4, 1/2, 3/4 or 4/4 bit position by programming Bit 3 and 4 of the Stream Input Control Registers (SICR).

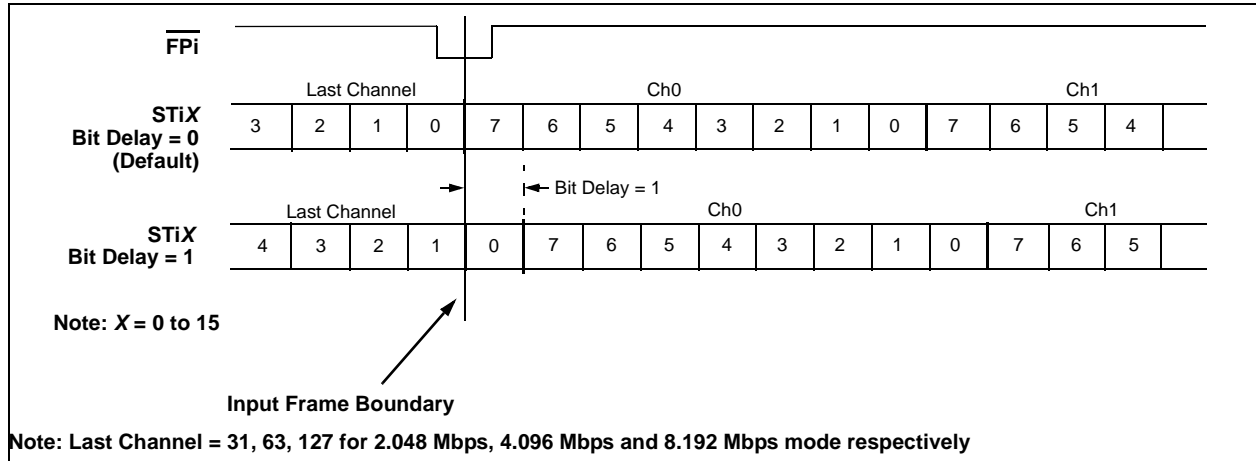

Figure 16 - Input Bit Delay Timing Diagram

### 2.3.4 Output Channel Delay Programming

This feature allows each output stream to have a different output frame boundary with respect to the output frame boundary defined by the output frame pulse ( $\overline{FPO0}$ ,  $\overline{FPO1}$  and  $\overline{FPO2}$ ) and the output clock ( $\overline{CKO0}$ ,  $\overline{CKO1}$  or  $\overline{CKO2}$ ). By default, all output streams have zero channel delay such that Ch 0 is the first channel that appears after the output frame boundary as shown in Figure 17. Different output channel delay can be set by programming Bit 5 to 11 in the Stream Output Offset Registers (SOOR). The output channel delay can vary from 0 to 31, 0 to 63 and 0 to 127 for the 2.048 Mbps, 4.096 Mbps and 8.192 Mbps modes respectively.

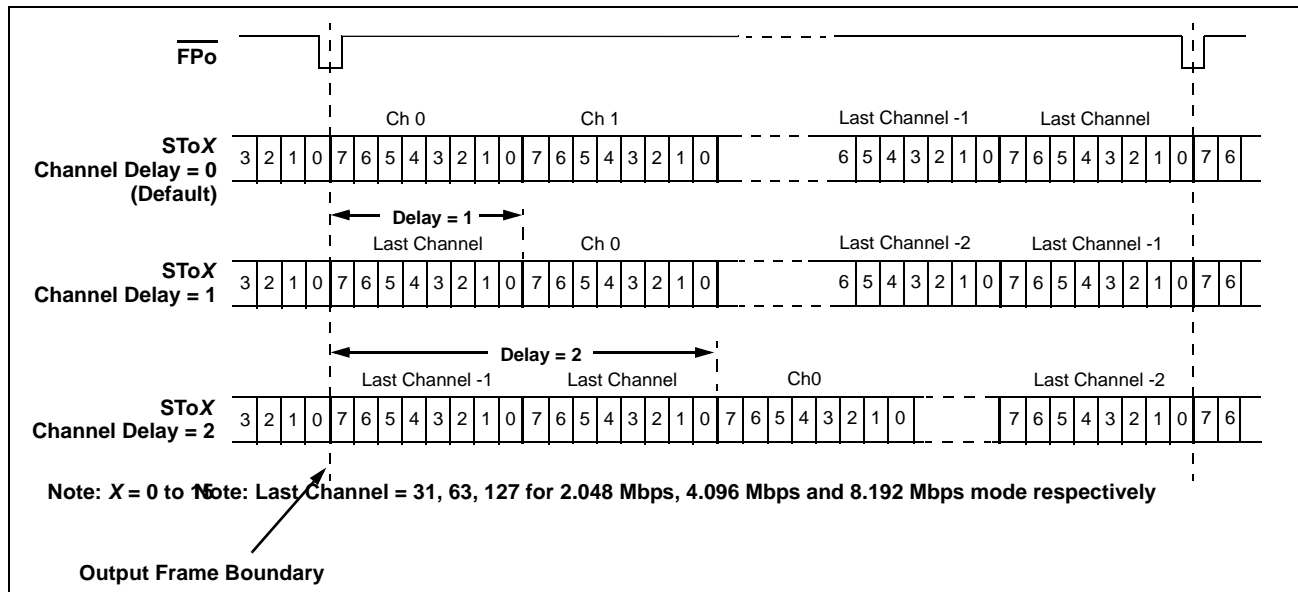

Figure 17 - Output Channel Delay Timing Diagram

### 2.3.5 Output Bit Delay Programming

This feature is used to delay the output data bit of individual output streams with respect to the output frame boundary. Each output stream can have its own bit delay value.

By default, all output streams have zero bit delay such that Bit 7 is the first bit that appears after the output frame boundary (see Figure 18 on page 24). Different output bit delay can be set by programming Bit 2 to 4 in the Stream Output Offset Registers. The output bit delay can vary from 0 to 7 bits.

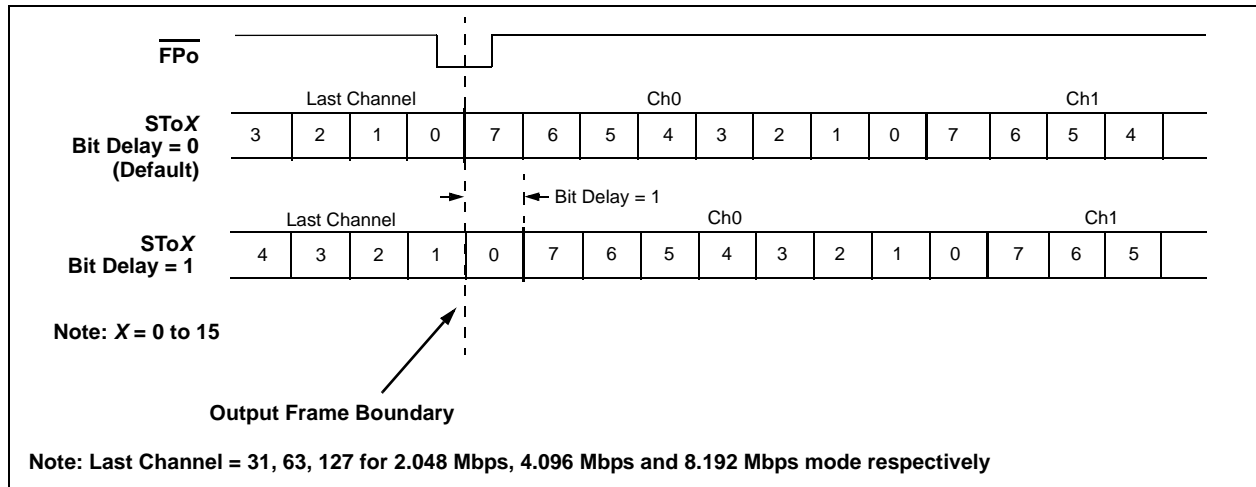

Figure 18 - Output Bit Delay Timing Diagram

### 2.3.6 Fractional Output Bit Advancement Programming

In addition to the output bit delay, the device is also capable of performing fractional output bit advancement. This feature offers a better resolution for the output bit delay adjustment. The fractional output bit advancement is useful in compensating for various parasitic loadings on the serial data output pins.

By default, all output streams have zero fractional bit advancement such that Bit 7 is the first bit that appears after the output frame boundary as shown in Figure 19. The fractional output bit advancement is enabled by Bit 0 to 1 in the Stream Output Offset Registers. The fractional bit advancement can vary from 0, 1/4, 1/2 or 3/4 bit.

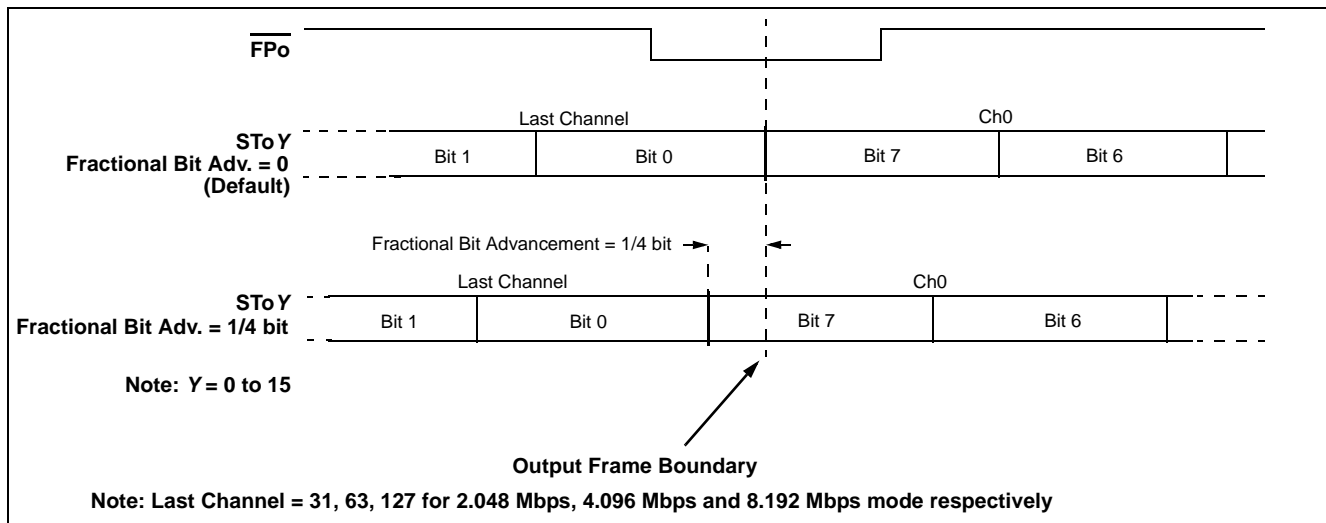

Figure 19 - Fractional Output Bit Advancement Timing Diagram



### 2.3.7 External High Impedance Control, STOZH 0 to 15

The STOZH 0 to 15 outputs are provided to control the external tristate ST-BUS drivers for per-channel high impedance operations. The STOZH outputs are sent out in 32, 64 or 128 timeslots corresponding to the output channels for 2.048 Mbps, 4.096 Mbps and 8.192 Mbps output streams respectively. Each control timeslot lasts for one channel time.

When the ODE pin is high, the STOZH 0 - 15 are enabled. When the ODE pin or the  $\overline{\text{RESET}}$  pin is low, the STOZH 0 - 15 are driven high. STOZH outputs are also driven high if their corresponding ST-BUS outputs are not in use.

Figure 20 gives an example when channel 2 of a given ST-BUS output is programmed in the high impedance state, the corresponding STOZH pin drives high for one channel time at the channel 2 timeslot.

By default, the output timing of the STOZH signals follow the same timing as their corresponding STo signals including any user-programmed channel and bit delay and fractional bit advancement. In addition, the device allows users to advance the STOZH signals from their default positions to a maximum of four 15.2 ns steps (or four 1/4 bit steps) using Bit 3 to 5 of the Stream Output Control Register (SOCR). Bit 6 in the Stream Output Control Register selects the step resolution as 15.2 ns or 1/4 data bit. The additional advancement feature allows the STOZH signals to better match the high impedance timing required by the external ST-BUS drivers.

When the device is in DPLL Master mode (or Freerun mode) and the additional STOZH advancement is set to zero, there is no phase difference between the STo0 - 15 and the STOZH 0 to 15. When the device is in DPLL Master mode (or Freerun mode) and the additional STOZH advance is **not** zero, the phase correction of 6.25 ns could happen between the STo0 - 15 and STOZH 0 to 15 because these outputs are clocked by various internal clock edges and the DPLL output has the intrinsic jitter of 6.25 ns.

When the device is in the DPLL Bypass Mode, there is no phase correction between the STo0 -15 of the STOZH 0-15 regardless whether the additional STOZH advancement is enabled or disabled.

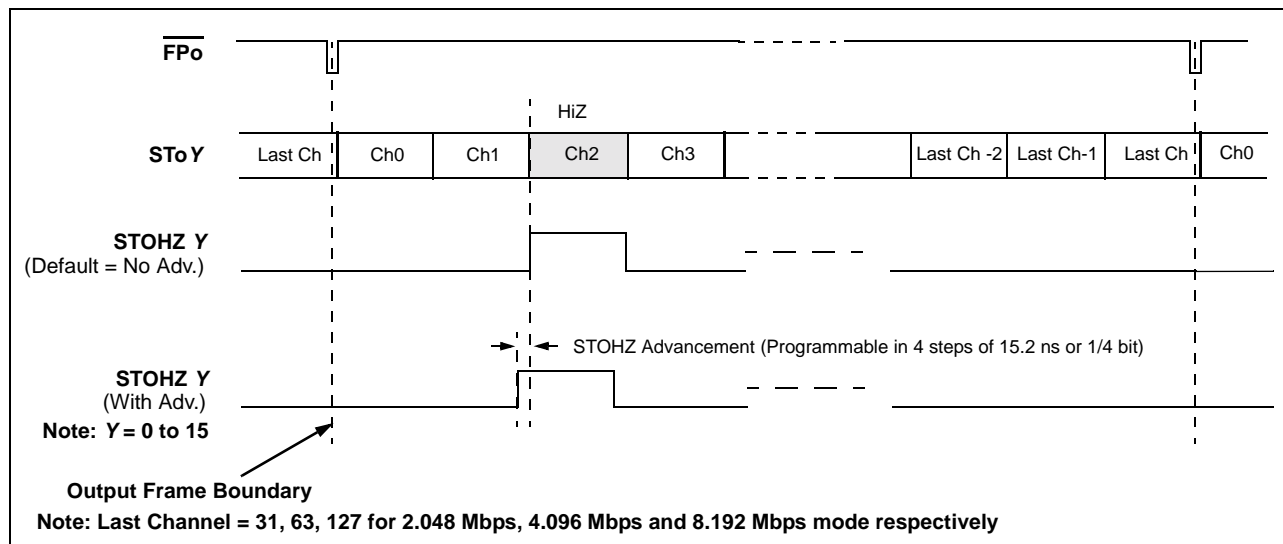

Figure 20 - Example: External High Impedance Control Timing

## 2.4 Data Delay Through The Switching Paths

To maintain the channel integrity in the constant delay mode, the usage of the input channel delay and output channel delay modes affect the data delay through various switching paths due to additional data buffers. The usage of these data buffers is enabled by the input and output channel delay bits (STIN#CD6-0 and STO#CD6-0) in the Stream Input Delay and Stream Output Offset Registers. However, the input and output bit delay or the input and output fractional bit offset have no impact on the overall data throughput delay.

In the following paragraphs, the data throughput delay (T) is expressed as a function of ST-BUS frames, input channel number (m), output channel number (n), input channel delay ( $\alpha$ ) and output channel delay ( $\beta$ ). Table 5 describes the variable range for input streams and Table 6 describes the variable range for output streams. Table 7 summarizes the data throughput delay under various input channel and output channel delay conditions.

Input Stream Data Rate	Input Channel Number (m)	Possible Input channel delay ( $\alpha$ )
2 Mbps	0 to 31	1 to 31
4 Mbps	0 to 63	1 to 63
8 Mbps	0 to 127	1 to 127

**Table 5 - Variable Range for Input Streams**

Output Stream Data Rate	Output Channel Number (n)	Possible Output channel delay ( $\beta$ )
2 Mbps	0 to 31	1 to 31
4 Mbps	0 to 63	1 to 63
8 Mbps	0 to 127	1 to 127

**Table 6 - Variable Range for Output Streams**

Input Channel Delay OFF Output Channel Delay OFF	Input Channel Delay ON Output Channel Delay OFF	Input Channel Delay OFF Output Channel Delay ON	Input Channel Delay ON Output Channel Delay ON
$T = 2 \text{ frames} + (n-m)$	$T = 3 \text{ frames} - \alpha + (n-m)$	$T = \text{frames} + \beta + (n-m)$	$T = 3 \text{ frames} - \alpha + \beta + (n-m)$

**Table 7 - Data Throughput Delay**

By default, when the input channel delay and output channel delay are set to zero, the data throughput delay ( $T$ ) is:  $T = 2 \text{ frames} + (m-n)$ . Figure 21 shows the throughput delay when the input Ch0 is switched to the output Ch0.

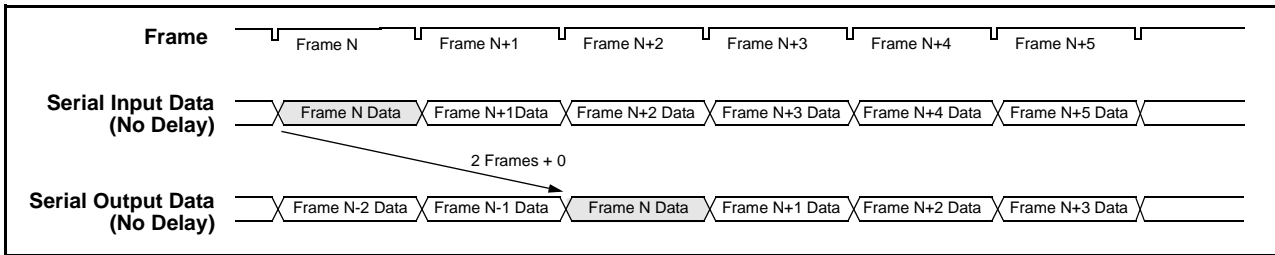

**Figure 21 - Data Throughput Delay when Input and Output Channel Delay are Disabled for Input Ch0 Switched to Output Ch0**

When the input channel delay is enabled and the output channel delay is disabled, the data throughput delay is:  $T = 3 \text{ frames} - \alpha + (m-n)$ . Figure 22 shows the data throughput delay when the input Ch0 is switched to the output Ch0.

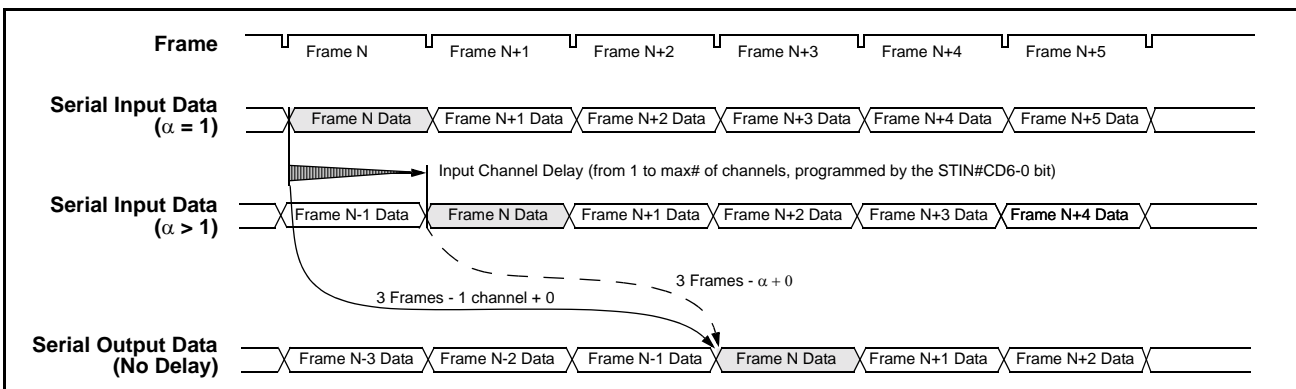

**Figure 22 - Data Throughput Delay when Input Channel Delay is Enabled and Output Channel Delay is Disabled for Input Ch0 Switched to Output Ch0**

When the input channel delay is disabled and the output channel delay is enabled, the throughput delay is:  $T = 2 \text{ frames} + \beta + (m-n)$ . Figure 23 shows the data throughput delay when the input Ch0 is switched to the output Ch0.

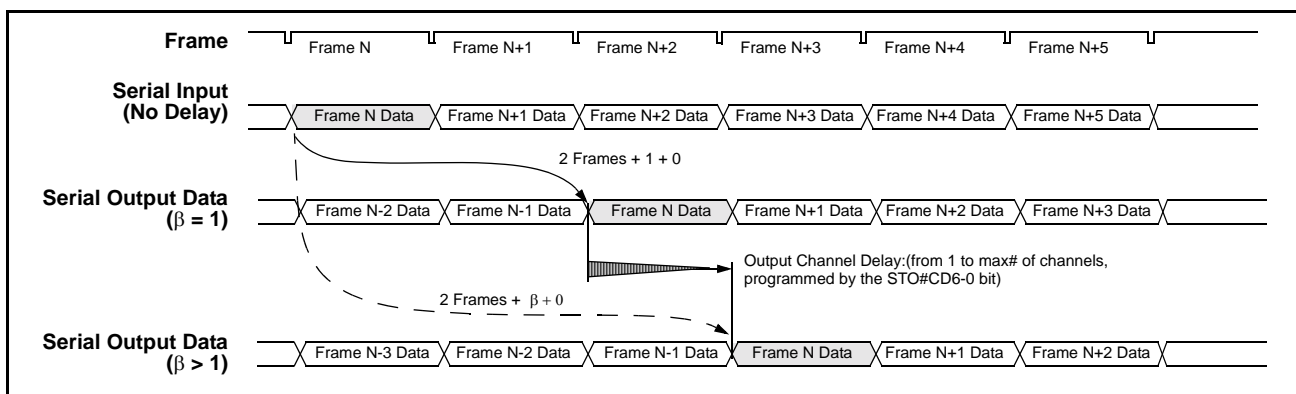

**Figure 23 - Data Throughput Delay when Input Channel Delay is Disabled and Output Channel Delay is Enabled for Input Ch0 Switch to Output Ch0**

When the input channel delay and the output channel delay are enabled, the data throughput delay is:  $T = 3 \text{ frames} - \alpha + \beta + (m-n)$ . Figure 24 shows the data throughput delay when the input Ch0 is switched to the output Ch0.

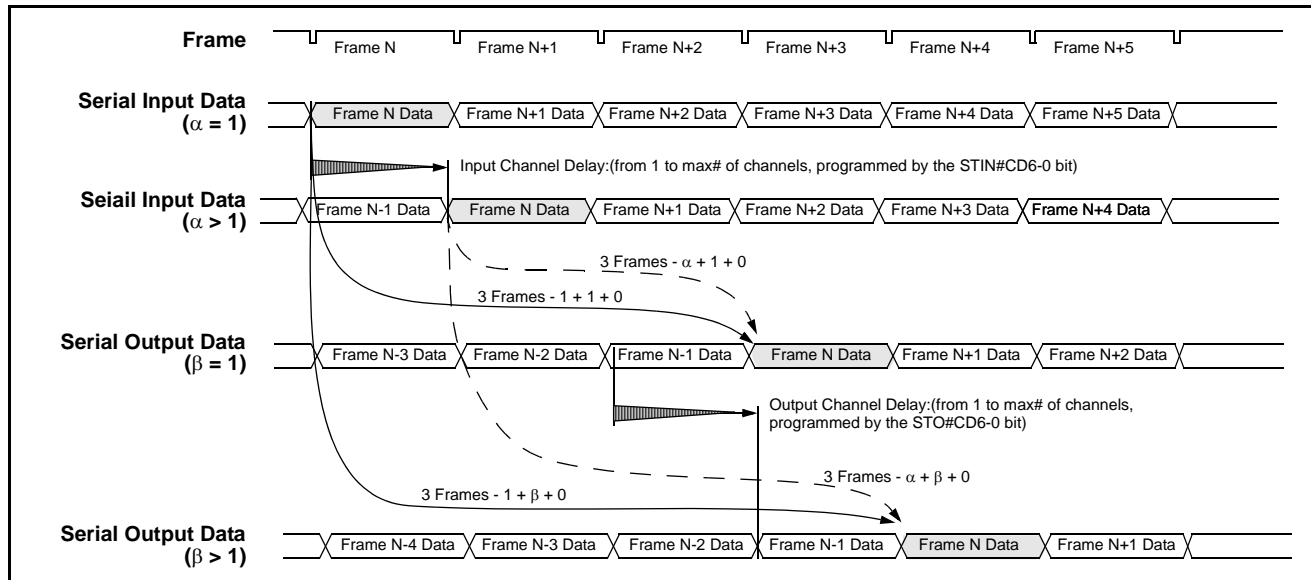

Figure 24 - Data Throughput Delay when Input and Output Channel Delay are Enabled for Input Ch0 Switched to Output Ch0

## 2.5 Connection Memory Description

The connection memory is 12-bit wide. There are 512 memory locations to support the ST-BUS serial outputs ST0-15. The address of each connection memory location corresponds to an output destination stream number and an output channel number. See Table on page 68 for the connection memory address map.

When Bit 0 of the connection memory is **low**, Bit 1 to 7 define the source (input) channel address and Bit 8 to 11 define the source (input) stream address. Once the source stream and channel addresses are programmed by the microprocessor, the contents of the data memory at the selected address are switched to the mapped output stream and channel. See Table 34 on page 69 for details on the memory bit assignment when Bit 0 of the connection memory is low.

When Bit 0 of the connection memory is **high**, Bit 1 and 2 define the per-channel control modes of the output streams, the per-channel high impedance output control, the per-channel message and the per-channel BER test modes. In the message mode, the 8-bit message data located in Bit 3 to 10 of the connection memory will be transferred directly to the mapped output stream. See Table 35 on page 69 for details on the memory bit assignment when Bit 0 of the connection memory is high.

### 2.5.1 Connection Memory Block Programming

This feature allows fast initialization of the entire connection memory after power up. When block programming mode is enabled, the content of Bit 1 to 3 in the Internal Mode Selection (IMS) Register will be loaded into Bit 0 to 2 of all the 512 connection memory locations. The other bit positions of the connection memory will be loaded with zeros.

**Memory block programming procedure:**

(Assumption: The MBPE and MBPS bits are both low at the start of the procedure)

- Program Bit 1 to 3 (BPD0 to BPD2) in the IMS (Internal Mode Selection) register.
- Set the Memory Block Programming Enable (MBPE) bit in the Control Register to high to enable the block programming mode.
- Set the Memory Block Programming Start (MBPS) bit to high in the IMS Register to start the block programming. The BPD0 to BPD2 bits will be loaded into Bit 0 to 2 of the connection memory. The other bit positions of the connection memory will be loaded with zeros. The memory content after block programming is shown in Table 8.
- It takes 50  $\mu$ s for the connection memory to be loaded with the bit pattern defined by the BPD0 to BPD2 bits.
- After loading the bit pattern to the entire connection memory, the device will reset the MBPS bit to low, indicating that the process has finished.
- Upon completion of the block programming, set the MBPE bit from high to low to disable the block programming mode.

**Note:** Once the block programming is started, it can be terminated at any time prior to completion by setting the MBPS bit or the MBPE bit to low. If the MBPE bit is used to terminate the block programming before completion, users have to set the MBPS bit from high to low before enabling other device operation.

11	10	9	8	7	6	5	4	3	2	1	0
0	0	0	0	0	0	0	0	0	BPD2	BPD1	BPD0

**Table 8 - Connection Memory in Block Programming Mode**

**2.6 Bit Error Rate (BER) Test**

The ZL50010 has one on-chip BER transmitter and one BER receiver. The transmitter can transmit onto a single STo output stream only. The transmitter provides a BER sequence ( $2^{15}-1$  Pseudo Random Code) which can start from any channel in the frame and lasts from one channel up to one frame time (125  $\mu$ s). The transmitter output channel(s) are specified by programming the connection memory location(s) corresponding to the channel(s) of the selected output stream: Bit 0 to 2 of the connection memory location(s) should be programmed to the BER test mode (see Table 35 on page 69).

Multiple connection memory locations can be programmed for BER test such that the BER patterns can be transmitted for several output channels which are consecutive. If the transmitting output channels are not consecutive, the BER receiver will not compare the bit patterns correctly.

The number of output channels which the BER transmitter occupies also has to be the same as the number of channels defined in the BER Length Register. The BER Length Register defines how many BER channels to be monitored by the BER receiver.

Registers used for setting up the BER test are as follows:

- Control Register (**CR**) - The CBER bit is used to clear the bit error counter and the BER Count Register (BCR). The SBER bit is used to start or stop the BER transmitter and BER receiver.
- BER Start Receiving Register (**BSRR**) - Defines the input stream and channel from where the BER sequence will start to be compared.
- BER Length Register (**BLR**) - Defines how many channels the sequence will last.

- BER Count Register (**BCR**) - Contains the number of counted errors. When the error count reaches Hex FFFF, the bit error counter will stop so that it will not overflow. Consequently the BER Count Register will also stop at FFFF. The CBER bit in the Control Register is used to reset the bit error counter and the BER Count Register.

As described above, the SBER bit in the control register controls the BER transmitter and receiver. To carry out the BER test, users should set the SBER bit to zero to disable the BER transmitter during the programming of the connection memory for the BER test. When the BER transmitter is disabled, the transmitter output is all ones. Hence any output channel whose connection memory has been programmed to BER test mode will also output all ones. Upon the completion of programming the connection memory for the BER test, set the SBER bit to one to start the BER transmitter and receiver for the BER testing. They must be allowed to run for several frames (2 frames plus the network delay between STo and STi) before the BER receiver can correctly identify errors in the pattern. Thus after this time the bit error counter should be reset by using the CBER bit in the Control Register - set CBER to one then back to zero. From now on, the count will be the actual number of errors which occurred during the test. The count will stop at FFFF and the counter will not increment even if more errors occurred.

## 2.7 Quadrant frame programming

By programming the input stream control registers (SICR0 to 15), users can divide 1 frame of input data into 4 quadrant frames and can force the Least Significant Bit (LSB, bit 0 in Figure 7 on page 17) of every input channel in these quadrants into "1" for the bit robbed signalling purpose. The 4 quadrant frames are defined as shown in Table 9.

Data Rate	Quadrant 0	Quadrant 1	Quadrant 2	Quadrant 3
2.048 Mbps	Ch 0 to 7	Ch 8 to 15	Ch 16 to 23	Ch 24 to 31
4.096 Mbps	Ch 0 to 15	Ch 16 to 31	Ch 32 to 47	Ch 48 to 63
8.192 Mbps	Ch 0 to 31	Ch 32 to 63	Ch 64 to 95	Ch 96 to 127

**Table 9 - Definition of the Four Quadrant Frames**

When a quadrant frame enable bit (STIN#QEN0, STIN#QEN1, STIN#QEN2 or STIN#QEN3) is set to high, the LSB of every input channels in the quadrant is forced to "1". See Table 10 to Table 13 for details:

STIN#QEN0	Action
1	Replace LSB of every channel in Quadrant 0 with "1"
0	No bit replacement occurs in Quadrant 0

**Table 10 - Quadrant Frame 0 LSB Replacement**

STIN#QEN1	Action
1	Replace LSB of every channel in Quadrant 1 with "1"
0	No bit replacement occurs in Quadrant 1

**Table 11 - Quadrant Frame 1 LSB Replacement**

STIN#QEN2	Action
1	Replace LSB of every channel in Quadrant 2 with "1"
0	No bit replacement occurs in Quadrant 2

**Table 12 - Quadrant Frame 2 LSB Replacement**

STIN#QEN3	Action
1	Replace LSB of every channel in Quadrant 3 with "1"
0	No bit replacement occurs in Quadrant 3

**Table 13 - Quadrant Frame 3 LSB Replacement**

## 2.8 Microprocessor Port

The device supports the non-multiplexed microprocessor. The microprocessor port consists of a 16 bit parallel data bus (D0 to 15), a 12 bit address bus (A0 to 11) and four control signals (CS, DS, R/W and DTA). The parallel microprocessor port provides fast access to the internal registers, the connection and the data memories.

The connection memory locations can be read or written via the 16 bit microprocessor port. On the other hand, the data memory locations can only be read (but not written) from the microprocessor port.

For the connection memory write operation, D0 to 11 of the data bus will be used and D12 to 15 are ignored (D12 to 15 should be driven low). For the connection memory read operation, D0 to D11 will be used and D12 to D15 will output zeros. For the data memory read operation, D0 to D7 will be used and D8 to D15 will output zeros.

See Table on page 68 for the address mapping of the data memory. Refer to Figure 48 on page 82 for the microprocessor port timing.

## 2.9 Digital Phase-Locked Loop (DPLL) Operation

The DPLL meets the requirements of Telcordia GR-1244-CORE Stratum 4 enhanced specifications (Stratum 4E). It can be set into one of three operating modes: Master, Freerun or Bypass.

The input streams STi0-15 are always sampled with the ST-BUS input clock  $\overline{CK}_i$ . The ST-BUS input frame pulse  $\overline{FP}_i$  denotes the input frame boundary. The objective of the DPLL is to generate the high speed internal clock MCKTDM (see Figure 25 on page 35). MCKTDM provides timing for the TDM switching function and timing for the ST-BUS outputs. (In this context  $\overline{CK}_{o0-2}$ ,  $\overline{FP}_{o0-2}$ , STo0-15 and STOHz0-15 are collectively known as the ST-BUS outputs.)

- In Master mode, the DPLL synchronizes to one of the timing reference inputs to generate the internal clock MCKTDM. Typically the timing references are from the network. The DPLL provides functions such as automatic bit-error-free reference switching, jitter attenuation and holdover. The Master mode ST-BUS output clocks and frame pulses are synchronized to the network reference and can be used as a system's ST-BUS timing source.
- In Freerun mode, the DPLL is not synchronized to any of the timing references. It synthesizes the internal clock MCKTDM based on the oscillator clock. Typically Freerun mode is used when a system's timing is independent of the network. In that case, the Freerun mode ST-BUS output clocks and frame pulses must be used as the system's ST-BUS timing source.
- In Bypass mode, the DPLL is completely bypassed. The Analog Phase-Locked Loop (APLL) synchronizes to the ST-BUS input clock  $\overline{CK}_i$  to generate the internal clock MCKTDM. Bypass mode is used when the system's ST-BUS timing is supplied by another device, e.g. another ZL50010 in Master mode.

Table 14 shows the three operating modes of the DPLL. The DPLL is controlled by the DOM (DPLL Operation Mode) register and bit 14 of the Control Register (CR). The DPLL's status is reported in the DPLL House Keeping Register (DHKR). The DPOA (DPLL Output Adjustment) register advances or delays the ST-BUS outputs with respect to the reference. These registers are described in Table 17 on page 50 for CR, Table 22 on page 55 for DOM, Table 23 on page 57 for DOA, and Table 24 on page 57 for DHKR.

Bit 14 of CR	Bit 0 of DOM	Mode
0	0	Master mode
0	1	Freerun mode
1	1 or 0	Bypass mode

**Table 14 - DPLL Operating Mode Settings**

The DPLL intrinsic jitter is 6.25 ns peak to peak. In Master and Freerun modes, the DPLL intrinsic jitter will be added onto the ST-BUS outputs. In Bypass mode, the DPLL is completely bypassed and the DPLL intrinsic jitter will not be added to the ST-BUS outputs.

### 2.9.1 DPLL Master Mode

DPLL Master mode is selected by the setting shown in Table 14. Asserting the  $\overline{\text{RESET}}$  pin low will also put the DPLL into Master mode since  $\overline{\text{RESET}}$  clears all the registers. In Master mode, the DPLL generates the MCKTDM clock synchronized to one of 3 timing reference signals. It provides jitter attenuation and holdover functions, and automatic reference switching between two of the timing references. MCKTDM provides timing for the TDM switching function and for the ST-BUS outputs. Hence the Master mode ST-BUS output clocks and frame pulses are synchronized to the reference and can be used to provide a system's ST-BUS timing.

#### 2.9.1.1 Master Mode Reference Inputs

The DPLL has access to two independent external references at the PRI\_REF and SEC\_REF input pins. Typically PRI\_REF and SEC\_REF are from the network. Additionally an internal 8 kHz signal (CKi/FPi) derived from the CKi and FPi inputs can be selected to replace PRI\_REF. The reference chosen from between PRI\_REF and CKi/FPi is called the primary reference. SEC\_REF is known as the secondary reference. The P\_REFSEL bit of the DOM register is used to select between PRI\_REF and CKi/FPi as the primary reference.

Either the primary reference (selected from between PRI\_REF and CKi/FPi) or the secondary reference (SEC\_REF) can be designated as the "preferred" reference via the REFSEL bit of the DOM register. The remaining reference becomes the "backup" reference. For example, if SEC\_REF is the preferred reference, then the backup reference is the primary reference selected from between PRI\_REF and CKi/FPi. The preferred and backup references are used in automatic reference switching.

The PRI\_REF and SEC\_REF inputs do not have to be at the same nominal frequency. Each can be independently programmed to be either 8 kHz, 1.544 MHz or 2.408 MHz via the FP1-0 and FS1-0 bits of the DOM register. When the internal 8 kHz signal CKi/FPi is selected as the primary reference instead of PRI\_REF, the FP1-0 bits must be set to 00.

The DPLL operates on the rising edge of the selected reference. The polarity of the PRI\_REF and SEC\_REF inputs can be inverted via the PINV and SINV bits of the DOM register.



### 2.9.1.2 Master Mode Reference Switching

The DPLL monitors both the primary and secondary reference. When the reference the DPLL is currently synchronized to becomes invalid, the DPLL's response depends on which one of the failure detect modes has been chosen: autodetect, forced primary or forced secondary. One of these failure detect modes must be chosen via the FDM1-0 bits of the DOM register. After a device reset via the RESET pin, the autodetect mode is selected.

In autodetect mode (automatic reference switching), if both references are valid, the DPLL will synchronize to the preferred reference. If the preferred reference becomes unreliable, the DPLL continues driving its output clock in a stable holdover state until it makes a switch to the backup reference. If the preferred reference recovers, the DPLL makes a switch back to the preferred reference. If necessary, the switch back can be prevented by changing the preferred reference using the REFSEL bit in the DOM register after the switch to the backup reference has occurred.

If both references are unreliable, the DPLL will drive its output clock using stable holdover values until one of the references becomes valid. If CKi/FPi is selected as the preferred reference, the user must ensure that the FPI and CKi input signals are re-applied after the CKi/FPi reference is lost (or failed). When the CKi/FPi reference is lost, since FPI and CKi are used to sample the input data streams STi0-15, the TDM switching from STi to STo will not work.

In forced primary mode, the DPLL will synchronize to the primary reference only. The DPLL will not switch to the secondary reference under any circumstance including the loss of the primary reference. If the primary reference failed, the DPLL will not go into holdover mode and synchronization will be lost. Similarly in forced secondary mode the DPLL will synchronize to the secondary reference only and will not switch to the primary reference or go into holdover under any circumstance. The choice of preferred reference has no effect in these forced modes.

When a conventional PLL is locked to its reference, there is no phase difference between the input reference and the PLL output. For the DPLL, the input references can have any phase relationship between them. During a reference switch, if the DPLL output follows the phase of the new reference, a large phase jump could occur. The phase jump would be transferred to the ST-BUS outputs. The DPLL's MTIE (Maximum Time Interval Error) feature preserves the continuity of the DPLL output so that it appears no reference switch had occurred. The MTIE circuit is not perfect however, and a small Time Interval Error is still incurred per reference switch. To align the DPLL output clock to the nearest edge of the selected input reference, the MTIE reset bit (MRST bit in the DOM register) can be used.

Unlike some designs, switching between references which are at different nominal frequencies do not require intervention such as device reset.

### 2.9.1.3 DPLL Status Reporting

Reference switching is managed by the state machine shown in Figure 27 on page 37. The state machine can be in one of six states corresponding to the names and numbers in the bubbles in Figure 27. The state number is reported in the ST2-0 bits of the DHKR register. The validity of the primary and secondary references are reported in the PFD and SFD bits of the DHKR register respectively.

### 2.9.1.4 Master Mode Output Offset Adjustment

The ST-BUS outputs ( $\overline{\text{CKo0-2}}$ ,  $\overline{\text{FPo0-2}}$ , STo0-15 and STOHz0-15) can be shifted to lead (advancement) or lag (delay) the reference. The DPOA register provides this adjustment. Coarse lead or lag adjustment is programmed via the POS6-0 bits, while fine delay (lag) control is via the SKC2-0 bits.

### 2.9.2 DPLL Freerun Mode

DPLL Freerun mode is selected by the setting in Table 14. In Freerun mode, the DPLL is not synchronized to any of the reference inputs. The DPLL synthesizes the internal clock MCKTDM very accurately. MCKTDM provides timing for the TDM switching function and for the ST-BUS outputs. Since the DPLL is not synchronized to any of the reference inputs, the ST-BUS outputs are also not synchronized to any of the reference inputs.

The DPLL can switch to the Freerun mode at any time. Freerun mode is typically used when a master clock source is required, or immediately following system power-up before network synchronization is achieved. If a ZL50010 is to be operated exclusively in Freerun mode, then its ST-BUS output clock and frame pulse must be used as the ST-BUS input clock and frame pulse to all TDM devices in the system, including the device itself.

### 2.9.3 DPLL Bypass Mode

DPLL Bypass mode is selected by setting high bit 14 of the Control Register (CR), as shown in Table 14. The DPLL is completely bypassed and the APLL takes its input from CKi instead of the oscillator. The APLL multiplies the ST-BUS input clock CKi with an appropriate frequency multiplication factor to generate the internal clock MCKTDM.

MCKTDM is synchronized to CKi. MCKTDM provides timing for the TDM switching function and for the ST-BUS outputs. Hence the ST-BUS outputs are synchronized to CKi. The DPLL intrinsic jitter will not be added onto the ST-BUS outputs because the DPLL is completely bypassed.

In this mode, the APLL takes its input from CKi instead of the oscillator. If the device is to be used in this mode only, the oscillator clock is not required and the external crystal oscillator or clock oscillator can be omitted. If the crystal oscillator or clock oscillator is omitted, the XTALi pin must be held low and the XTALo pin must be left unconnected.

Bypass mode is used when another device, such as another ZL50010 in Master mode, is providing system timing.

### 2.10 DPLL Functional Description

Figure 25 shows the functional block diagram of the DPLL. Major functional blocks are described in the following sections. When the DPLL is in Master or Freerun mode, the APLL input is C20i from the oscillator and the APLL multiplies C20i to generate the DPLL master clock MCKDPLL.

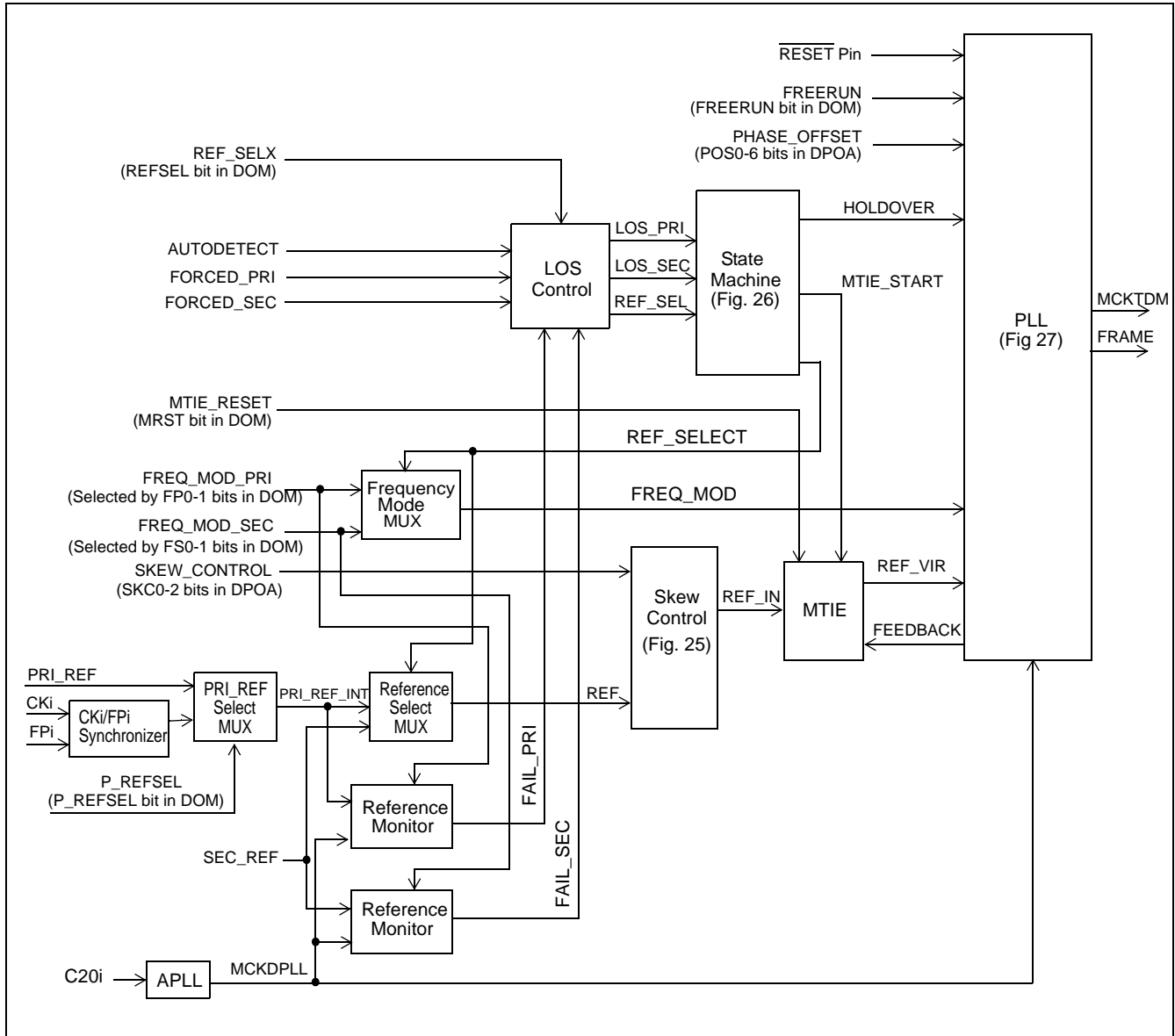

Figure 25 - DPLL Functional Block Diagram

#### 2.10.1 CKi/FPi Synchronizer and PRI\_REF Select Mux Circuits

The ST-BUS input frame pulse ( $\overline{FPI}$ ) is sampled with the ST-BUS input clock ( $\overline{CKi}$ ) inside the CKi/FPi synchronizer to create the 8 kHz reference CKi/FPi. Either CKi/FPi or PRI\_REF is selected by the reference select bit (P\_REFSEL in the DOM register) as the PRI\_REF\_INT input to the Reference Select Mux in Figure 25.

### 2.10.2 Reference Select and Frequency Mode Mux Circuits

The DPLL accepts two simultaneous reference inputs and operates on their rising edges. The State Machine output REF\_SELECT chooses either the primary reference (PRI\_REF\_INT signal) or the secondary reference (SEC\_REF signal) as the REF input to the Skew Control circuit. REF\_SELECT also selects the frequency mode input (FREQ\_MOD) to the PLL block from either FREQ\_MOD\_PRI or FREQ\_MOD\_SEC. These are two bit wide signals from the DOM register: FREQ\_MOD\_PRI corresponds to the FP1-0 bits, FREQ\_MOD\_SEC corresponds to the FPS1-0 bits.

### 2.10.3 Skew Control Circuit

The Skew Control circuit delays the selected reference input with an 8 tap tapped delay line (see Figure 26). The nominal delay between taps is 1.9 ns. Thus the selected reference can be delayed by 0 to 13.3 ns in steps of 1.9 ns (0 to 7 steps). The output tap is selected by SKEW\_CONTROL which corresponds to the SKC2-0 bits of the DPLL Output Adjustment (DPOA) register. Skewing the reference will cause the feedback signal in the PLL block (FEEDBACK in Figure 28 on page 38) to be delayed by the skew amount with respect to the original reference. This will cause the DPLL output to be delayed by the skew amount. Hence the ST-BUS outputs will be delayed by the skew amount.

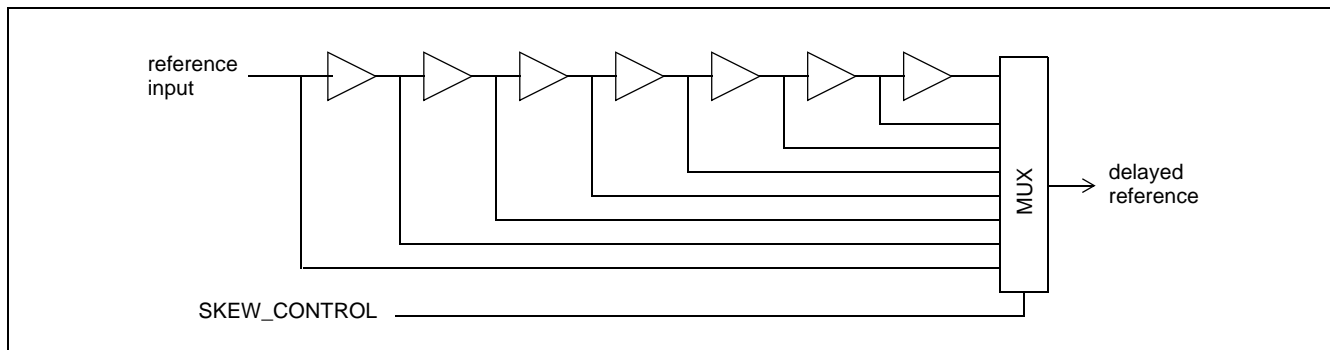

Figure 26 - Skew Control Circuit Diagram

### 2.10.4 Reference Monitor Circuit

There are two identical Reference Monitor circuits, one for the primary reference PRI\_REF\_INT and one for the secondary reference SEC\_REF. Each circuit continuously monitors its reference and reports the reference's validity. The output signals are FAIL\_PRI and FAIL\_SEC for the primary and secondary monitors respectively. A logic high on either signal indicates that the corresponding reference has become invalid. The validity criteria depends on the frequency programmed for the reference. A reference must meet all criteria applicable to its frequency, which are:

- The "minimum 90 ns" check is performed regardless of the programmed frequency. Both the logic high and low duration of the reference must be at least 90 ns.
- The "period in specified range" check is performed regardless of the programmed frequency. Each period must be within a range. For 1.544 MHz and 2.048 MHz, the range is  $1 - 1/4$  to  $1 + 1/4$  nominal period. For 8 kHz, the range is  $1 - 1/32$  to  $1 + 1/32$  nominal period.
- If the programmed frequency is 1.544 MHz or 2.048 MHz, the "64 periods in specified range" check will be performed. The time taken for 64 consecutive cycles must be between 62 and 66 periods of the programmed frequency.

The FAIL\_PRI and FAIL\_SEC signals are available at the DHKR register PFD and SFD bits respectively. They are not affected by the choice of the preferred reference or failure detect mode and will always report the validity of the primary and secondary references respectively.

### 2.10.5 LOS Control Circuit

LOS Control uses the results from the reference monitors to influence the transition of the State Machine. The outputs of LOS Control are affected by the choice of the failure detect mode (one of autodetect, forced primary, and forced secondary modes chosen via the DOM register FDM1-0 bits) as shown in Table 15.

Failure Detect Mode	LOS_PRI	LOS_SEC	REF_SEL
Autodetect	FAIL_PRI (from primary reference monitor)	FAIL_SEC (from secondary reference monitor)	REF_SELX (REFSEL bit in DOM) (0: primary is preferred reference) (1: secondary is preferred reference)
Forced Primary	0	1	0
Forced Secondary	1	0	1

Table 15 - LOS Outputs in the Failure Detect Modes

### 2.10.6 State Machine Circuit

The State Machine manages the reference rearrangement process. The State Machine can be in one of the six states shown as bubbles in Figure 27. Each bubble shows the state name and state number. Depending on the 3 bit LOS Control output {LOS\_PRI, LOS\_SEC, REF\_SEL} shown in Table 15, the State Machine selects either PRI\_REF\_INT or SEC\_REF as the current reference. In autodetect mode, the State Machine transitions between the states during reference rearrangement and switches the PLL circuit between normal and holdover operations. When the DPLL goes from holdover to normal operation, the State Machine goes through the MTIE PRI or MTIE SEC state to activate the MTIE circuit. The MTIE circuit prevents any significant phase shift at the PLL output clock during the reference switch. Note that the PLL is still outputting holdover clock during the MTIE PRI or MTIE SEC state.

In forced primary mode, the state machine will always stay in "Normal PRI" and never transition to "Holdover PRI". In forced secondary mode, the state machine will always stay in "Normal SEC" and never transition to "Holdover SEC".

The DHKR register ST2-0 bits report the state number. In autodetect mode, the ST2-0 bits will follow the state transitions. In forced primary mode, ST2-0 is always 0. In forced secondary mode, ST2-0 is always 4.

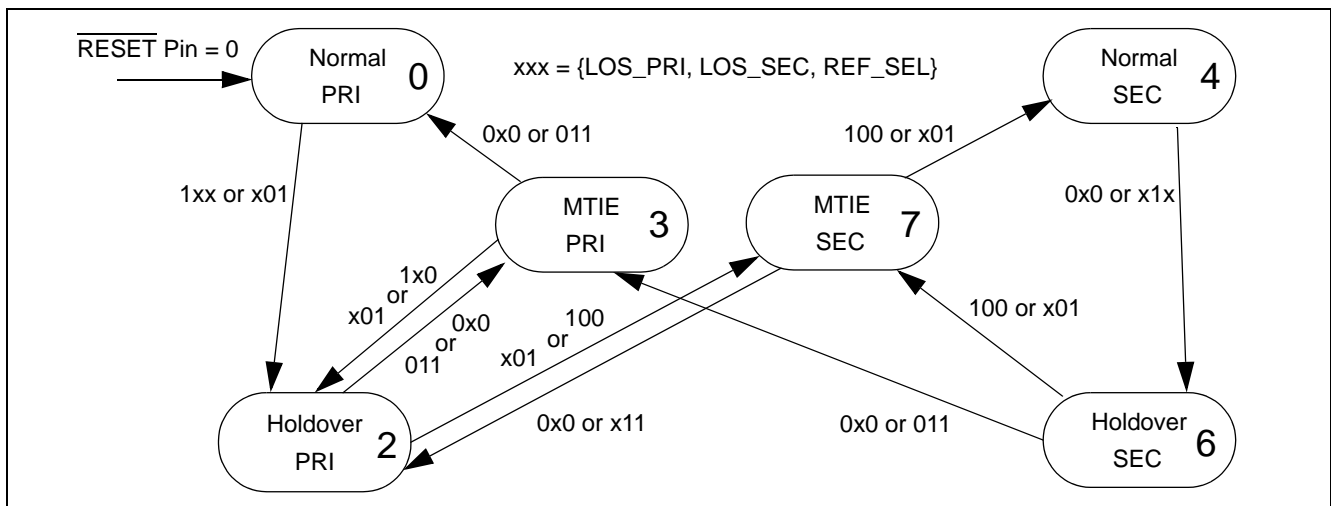

Figure 27 - State Machine Diagram

### 2.10.7 Maximum Time Interval Error (MTIE) Circuit

The MTIE circuit prevents any significant change in the DPLL output clock phase during a reference switch. The input references can have any relationship between their phases. The DPLL output follows the selected input reference. Thus a switch from one reference to another could cause a large phase jump in the DPLL output if the MTIE circuit did not exist. The phase jump would be transferred to the ST-BUS outputs. The MTIE circuit works to preserve the continuity of the DPLL output so that it appears no reference switch had occurred.

The MTIE circuit receives the skewed reference from the Skew Control circuit and delays it. This delayed signal is used as a virtual reference (REF\_VIR in Figure 25 on page 35) to input to the PLL block. Therefore the virtual reference is a delayed version of the selected reference. During a reference switch, the state machine first changes the operation of the PLL from normal to holdover. In holdover, the PLL no longer uses the virtual reference signal, but generates a stable output clock using stored values. When the state machine changes to MTIE PRI or MTIE SEC, the PLL block remains operating in holdover. The MTIE circuit measures the phase delay between the current phase (FEEDBACK signal in Figure 25 on page 35) and the phase of the new reference signal (REF\_IN in Figure 25). The MTIE circuit stores the measured delay. From now on the MTIE circuit always delays the reference signal by the stored value to become the virtual reference. The virtual reference is now at the same phase position it would have been if the reference switch had not taken place. The state machine then returns the PLL to normal operation.

The PLL now uses the new virtual reference signal. Since no phase step took place at the input of the PLL, no phase step occurs at the PLL output. In other words, reference switching will not cause a phase change at the PLL block input, or at the PLL output.

During the measurement process, the new reference is sampled asynchronously with an internal clock. Thus the delay between the new reference and the old virtual reference has a small measurement error. This measurement error will cause a small phase change (Time Interval Error) at the PLL output. Even if there is no phase difference between the primary and secondary references, each time a reference switch is made the delay (phase offset) between the DPLL input and output will change. The value of the delay is the sum of the measurement errors from all the reference switches. After many switches, the delay between the selected input reference and the DPLL output can become unacceptably large. The user should provide MTIE reset (via MRST bit in the DOM register) to realign the output clock to the nearest edge of the selected input reference. After the realignment, the phase offset between the input reference and DPLL output is the amount programmed into the DPOA register POS6-0 and SKC2-0 bits.

### 2.10.8 Phase-Locked Loop (PLL) Circuit

As shown in Figure 28, the PLL circuit consists of a Phase Detector, Phase Offset Adder, Phase Slope Limiter, Loop Filter, Digitally Controlled Oscillator, Divider and Frequency Select Mux.

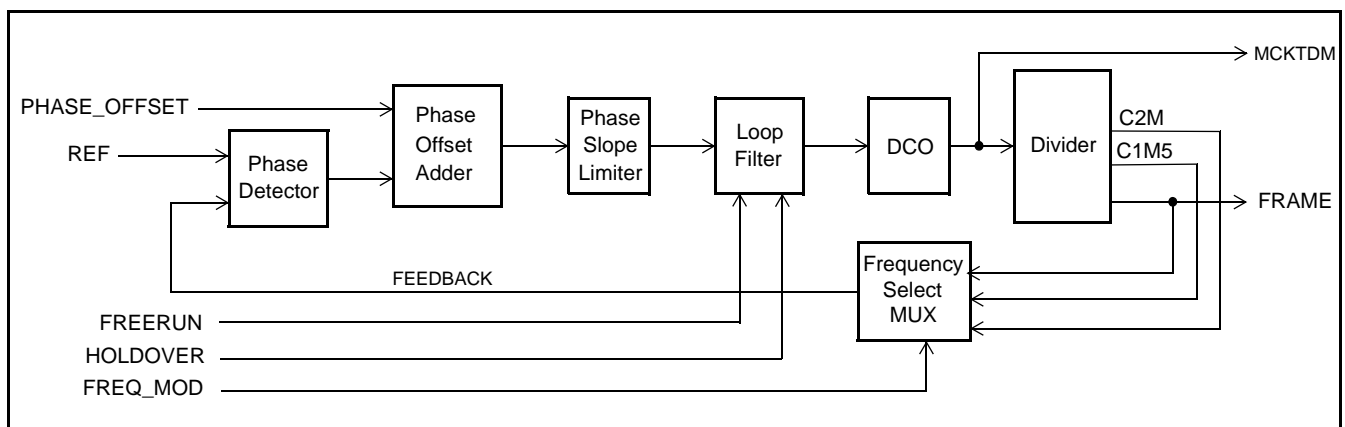

Figure 28 - Block Diagram of the PLL Module

**Phase Detector** - The Phase Detector compares the virtual reference signal from the MTIE circuit (REF\_VIR) with the FEEDBACK signal from the Frequency Select Mux. It provides an error signal corresponding to the phase difference between the signals' rising edges. This error signal is passed to the Phase Offset Adder.

**Phase Offset Adder** - The Phase Offset Adder adds the PHASE\_OFFSET word (POS6-0 bits of the DPOA register) to the error signal from the Phase Detector to create the final phase error. This value is passed to the Phase Slope Limiter. The phase offset word (POS6-0) can be positive or negative. Since the PLL will stabilize to a situation where the average Phase Offset Adder output is zero, a non-zero phase offset word will result in a static phase offset between the input and output of the DPLL.

The phase offset word is a 7-bit 2's complement value. If the selected input reference is 8 kHz or 2.048 MHz, the step size of the static phase offset is 15.2 ns. The static phase offset can be set between -0.96  $\mu$ s and +0.97  $\mu$ s. If the selected input reference is 1.544 MHz, the step size is 20.2 ns and the static phase offset can be set between -1.27  $\mu$ s and +1.29  $\mu$ s.

The resolution of the Skew Control circuit is 1.9 ns. Its effect is additional to that of the phase offset word. Thus using the Skew Control bits (SKC2-0 of the DPOA register) together with the phase offset word, users can set a total static phase offset between -0.96  $\mu$ s and +0.99  $\mu$ s if the selected input reference is either 8 kHz or 2.048 MHz. If the selected reference is 1.544 MHz, the total static phase offset can be between -1.27  $\mu$ s and +1.30  $\mu$ s.

**Phase Slope Limiter** - The Phase Slope Limiter receives the error signal from the Phase Offset Adder and ensures that the DPLL output responds to all input transient conditions with an output phase slope below a preset limit. The limit is based upon telecom standards requirements.

**Loop Filter** - The Loop Filter is similar to a first order low pass filter with a 1.52 Hz cutoff frequency for all 3 reference frequency selections (8 kHz, 1.544 MHz or 2.048 MHz). This filter defines the jitter transfer characteristic of the DPLL.

**Digitally Controlled Oscillator (DCO)** - The DCO generates a high speed digital clock output. The DCO's frequency is modulated by the frequency offset value from the Loop Filter. The DCO output is the MCKTDM clock in Figure 25 on page 35 and Figure 28 on page 38. MCKTDM provides timing for the TDM switching function, and timing for the ST-BUS outputs.

When the State Machine is in the Normal state, the DCO accepts the offset frequency value which represents the limited and filtered phase error between the input reference and the DCO feedback signal. Based on the offset value the DCO generates an output clock which is synchronized to the selected input reference.

When the State Machine is in the Holdover state, the DCO uses a frequency offset value which has been stored 32 ms to 64 ms prior to exiting from the Normal state. Thus the DCO is running at the same frequency it was previously running at when the State Machine was in the Normal state.

When the DPLL is in Freerun mode, the frequency offset is ignored and the DCO is free running at its preset center frequency.

**Divider** - The Divider divides down the DCO output frequency. The following signals are generated:

- C2M (a 2.048 MHz clock)
- C1M5 (a 1.544 MHz clock)
- FRAME (an 8 kHz frame pulse)

One of these signals is selected as the PLL feedback reference signal by the Frequency Select Mux circuit. The clocks have 50% nominal duty cycle. FRAME is a 122 ns wide negative frame pulse. The duty cycle of the clocks are not affected by the crystal oscillator duty cycle. Since these signals are generated from a common signal inside the DPLL, the frame pulse and clock outputs are always locked to one another. They are also locked to the selected input reference when the DPLL is in lock.

**Frequency Select Mux** - According to the selected input reference of the DPLL, this multiplexer will select the appropriate divider output C2M, C1M5 or FRAME as the feedback signal to the PLL and MTIE circuits.

## 2.11 DPLL Performance

The following are some synchronizer performance indicators and their definitions. The performance of the DPLL is also indicated.

### 2.11.1 Intrinsic Jitter

Intrinsic jitter is the jitter produced by a synchronizer and is measured at its output. It is measured by applying a jitter free reference signal to the input of the device, and measuring its output jitter. Intrinsic jitter may also be measured when the device is in a non-synchronizing mode, such as free running or holdover, by measuring the output jitter of the device. Intrinsic jitter is usually measured with various band-limiting filters depending on the applicable standards.

Intrinsic jitter is applicable only in Master and Freerun modes since in Bypass mode the DPLL is completely bypassed.

The DPLL's intrinsic jitter is 6.25 ns peak to peak. The intrinsic jitter will be added to the ST-BUS outputs  $\overline{\text{CKo0-2}}$ ,  $\overline{\text{FPo0-2}}$ ,  $\overline{\text{Sto0-15}}$  and  $\overline{\text{STOHZ0-15}}$ . Since the DPLL master clock (MCKDPLL) comes from the on chip APLL which is driven by the oscillator, any jitter on the oscillator will be added unattenuated onto the intrinsic jitter.

### 2.11.2 Jitter Tolerance

Jitter tolerance is a measure of the ability of a PLL to operate properly without cycle slips (i.e., remain in lock and/or regain lock in the presence of large jitter magnitudes at various jitter frequencies) when jitter is applied to its reference. The applied jitter magnitude and the jitter frequency depends on the applicable standards.

The DPLL's jitter tolerance meets Telcordia GR-1244-CORE DS1 reference input jitter tolerance requirements.

### 2.11.3 Jitter Transfer

Jitter transfer or jitter attenuation refers to the magnitude of jitter at the output of a device for a given amount of jitter at the input of the device. Input jitter is applied at various amplitudes and frequencies, and output jitter is measured with various filters depending on the applicable standards.

Since intrinsic jitter is always present, jitter attenuation will appear to be lower for small input jitter signals than for large ones. Consequently, accurate jitter transfer function measurements are usually made with large input jitter signals (e.g., 75% of the specified maximum jitter tolerance).

The DPLL's jitter transfer characteristic is determined by the internal 1.52 Hz low pass Loop Filter and the Phase Slope Limiter. The DPLL is a second order, Type 2 PLL. Figure 29 on page 41 shows the DPLL jitter transfer characteristic over a wide range of frequencies, while Figure 30 on page 41 expands the portion of Figure 29 around the 0 dB jitter transfer region. The jitter transfer function can be described as a low pass filter to 1.52 Hz, -20 dB/decade, with peaking less than 0.5 dB.

### 2.11.4 Frequency Accuracy

Frequency accuracy is defined as the absolute tolerance of an output clock when the synchronizer is not locked to an external reference, but is in a free running mode.

In Freerun mode, the DPLL is not synchronized to any reference. The DPLL provides output clocks and frame pulses based on the DPLL master clock. The PLL block's DCO circuit ignores its frequency offset input and free runs at its center frequency. Because of the granularity of the center frequency control value, the DCO free run frequency is -0.03 ppm off the ideal frequency. The DCO is clocked by the DPLL master clock MCKDPLL. The APLL generates the DPLL master clock from the oscillator. Thus the DPLL free run accuracy is affected by the oscillator accuracy. The DPLL free run accuracy is -0.03 ppm plus the accuracy of the oscillator.



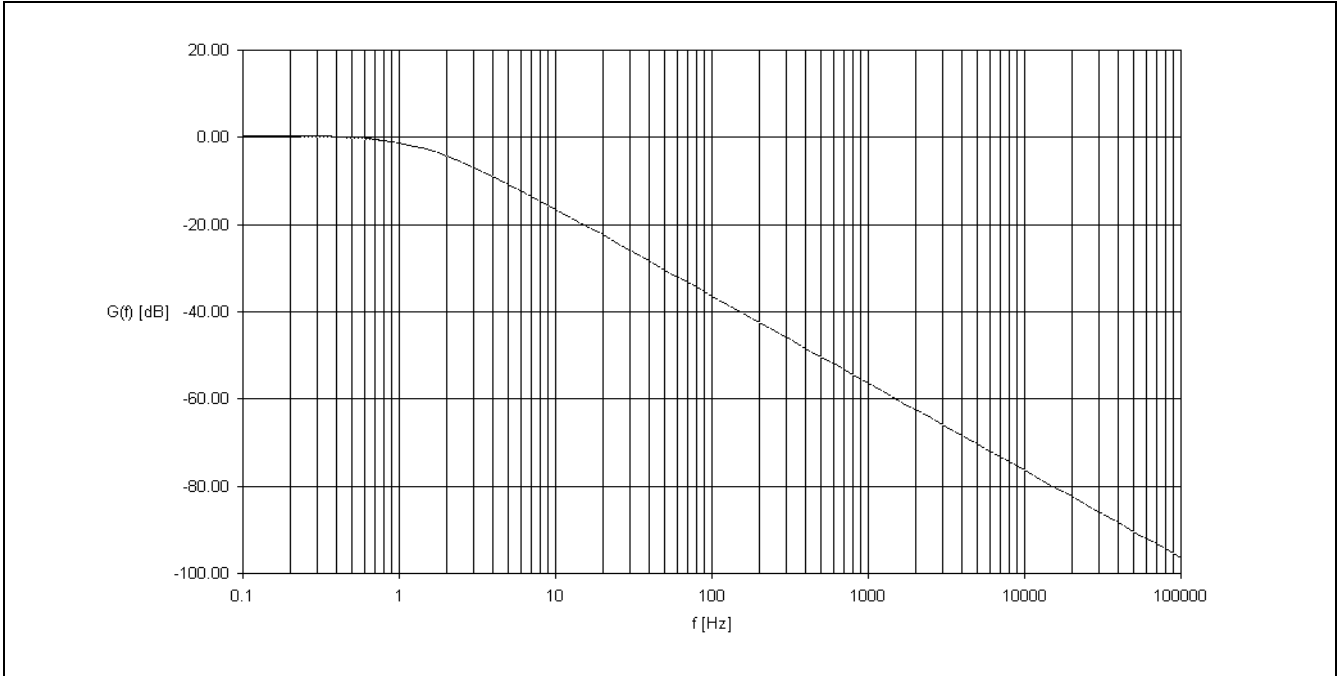

Figure 29 - DPLL Jitter Transfer Function Diagram - Wide Range of Frequencies

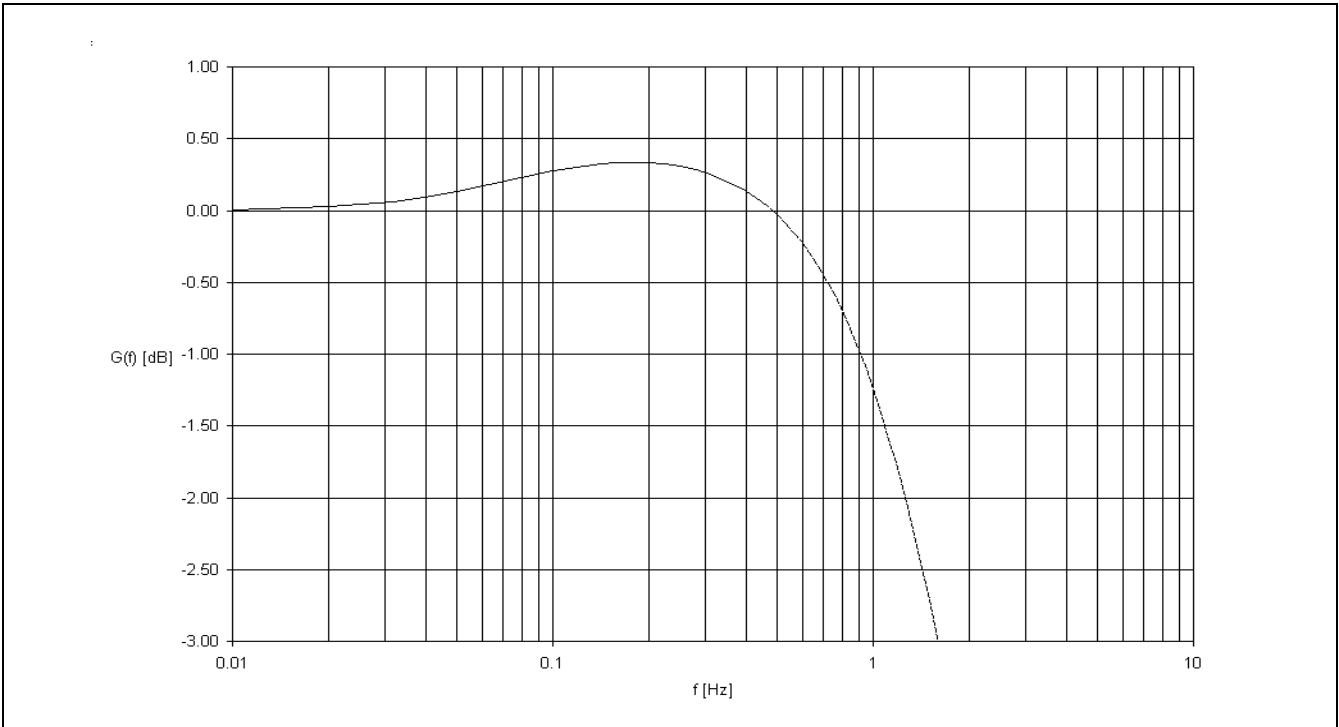

Figure 30 - Detailed DPLL Jitter Transfer Function Diagram (Wander Transfer Diagram)

### 2.11.5 Holdover Accuracy

Holdover accuracy is defined as the absolute tolerance of an output clock signal, when the synchronizer is not locked to an external reference signal but is operating using storage techniques.

In the Holdover state, the DPLL is not locked to any reference. The DPLL generates its output clock MCKTDM using values which were stored while the DPLL was locked to the selected reference in the Normal state. The values were stored 32 ms to 64 ms prior to exiting from the Normal state.

Two factors affect the holdover accuracy: large jitter on the reference prior to the state change, and the oscillator frequency drift since the state change. Note that it is the change in the oscillator frequency between the Normal and Holdover states which affect holdover accuracy, not the absolute frequency of the oscillator.

The DPLL master clock is derived from the oscillator. When the DPLL is in lock, the DPLL output frequency is exactly the same as that of the input reference. The DPLL will compensate for any changes in the absolute frequency of the oscillator. In Holdover, the DPLL output frequency is generated using values stored while the DPLL was in lock. Thus the DPLL can no longer compensate for changes in the oscillator frequency. The holdover frequency will change if the oscillator frequency has deviated since the DPLL was in lock.

When there was no jitter in the reference, and there is no change in the oscillator frequency, the DPLL holdover accuracy is within  $\pm 0.07$  ppm, which translates into maximum 49 frame slips (6.125 ms) in 24 hours.

Any change in the oscillator frequency since the transition out of the Normal state will change the holdover frequency. For example, a  $\pm 32$  ppm oscillator may have a temperature coefficient of  $\pm 0.1$  ppm/ $^{\circ}$ C. Thus a  $10^{\circ}$ C change since the DPLL was last in the Normal state will change the holdover frequency by an additional  $\pm 1$  ppm, which is much greater than the  $\pm 0.07$  ppm of the DPLL.

### 2.11.6 Locking Range

The locking range is the input frequency range over which the DPLL must be able to pull into synchronization and to maintain the synchronization. The locking range is defined by the Loop Filter circuit and is equal to  $\pm 298$  ppm.

Note that the locking range is related to the oscillator frequency. If the oscillator frequency is  $-100$  ppm, the whole locking range also shifts by  $-100$  ppm downwards to become  $-398$  ppm to  $+198$  ppm.

### 2.11.7 Phase Slope

The phase slope, or phase alignment speed, is the rate at which a given signal changes phase with respect to an ideal signal. The given signal is typically the output signal. The ideal signal is of constant frequency and is nominally equal to the value of the final output signal or final input signal. Many telecom standards state that the phase slope may not exceed a certain value, usually 81 ns/1.327 ms (61 ppm). This can be achieved by limiting the phase detector output to 61 ppm or less.

For the DPLL, the Phase Slope Limiter circuit limits the maximum phase slope to 56 ppm or 7 ns/125  $\mu$ s. The phase slope limit meets Telcordia GR-1244-CORE requirements.

### 2.11.8 MTIE

MTIE (Maximum Time Interval Error) is the maximum peak to peak delay between a given timing signal and an ideal timing signal within a particular observation period.

For the DPLL, MTIE is less than 21 ns per reference switch.

### 2.11.9 Phase Lock Time

The Phase Lock Time is the time it takes a synchronizer to phase lock to the input signal. Phase lock occurs when the input and the output signals are not changing in phase with respect to each other (not including jitter).

Lock time is very difficult to determine because it is affected by many factors which include:

- i) initial input to output phase difference
- ii) initial input to output frequency difference
- iii) PLL loop filter
- iv) PLL limiter

Although a short phase lock time is desirable, it is not always achievable due to other synchronizer requirements. For instance, better jitter transfer performance is obtained with a lower frequency loop filter which increases lock time; and better (smaller) phase slope performance (limiter) will increase lock time.

The DPLL loop filter and limiter have been optimized to meet the Telcordia GR-1244-CORE jitter transfer and phase alignment speed requirements. If the frequency of the DPLL internal feedback signal is -50 ppm and the frequency of the input reference is +50 ppm, then the phase lock time is typically 15 seconds. However, in a device power up situation, phase lock time can be up to 50 seconds. The phase lock time meets Telcordia GR-1244-CORE Stratum 4E requirements.

### 2.12 Alignment Between Input and Output Frame Pulses

When the device is in DPLL Master mode, and CKi/FPi is the selected input reference and has no jitter, then the ST-BUS output frame pulses align very closely to the ST-BUS input frame pulse. See Figure 40 on page 75 for details. (The alignment shown is for when all bits in the DPOA register are 0.) If the CKi/FPi reference has jitter, the output frame pulses will still align to the input frame pulse but the offset value is a function of the input jitter.

When the device is in DPLL Master mode, and the selected input reference is **not** CKi/FPi, then the output frame pulses have no relationship with respect to the input frame pulse. In this case, the device's output frame pulse(s) must be used as the frame pulse(s) for the system, which means that the output frame pulse(s) will be supplied as the input frame pulse to all devices, including the device itself.

When the device is in DPLL Bypass Mode, the output frame pulses align closely to the input frame pulse. See Figure 40 for details.

### 3.0 Oscillator Requirements

In DPLL Master and Freerun modes, the APLL module requires a 20 MHz clock source at the XTALi pin. The 20 MHz clock can be generated by connecting an external crystal oscillator to the XTALi and XTALo pins, or by connecting an external clock oscillator to the XTALi pin.

If the device is to be used in DPLL Bypass mode only, the 20 MHz clock is not required and the crystal oscillator or clock oscillator can be omitted. If the crystal oscillator or clock oscillator is omitted, the XTALi pin must be held low and the XTALo pin must be left unconnected.

#### 3.1 External Crystal Oscillator

A complete external crystal oscillator circuit made up of a crystal, resistor and capacitors is shown in Figure 31.

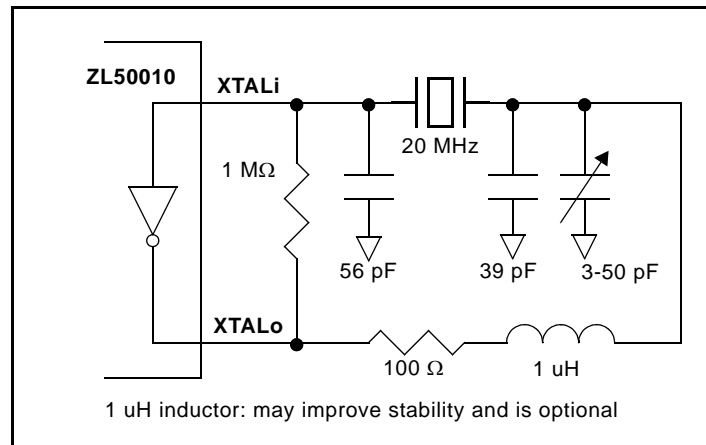

**Figure 31 - Crystal Oscillator Circuit**

The accuracy of a crystal oscillator circuit depends on the crystal tolerance as well as the load capacitance tolerance. Typically, for a 20 MHz crystal specified with a 32 pF load capacitance, each 1 pF change in load capacitance contributes approximately 9ppm to the frequency deviation. Consequently, capacitor tolerances, and stray capacitances have a major effect on the accuracy of the oscillator frequency.

The trimmer capacitor may be used to compensate for capacitive effects. If accuracy is not a concern, then the trimmer may be removed, the 39 pF capacitor may be increased to 56 pF, and a wider tolerance crystal may be substituted.

The crystal should be a fundamental mode type - not an overtone. The fundamental mode crystal permits a simpler oscillator circuit with no additional filter components and is less likely to generate spurious responses. The crystal accuracy only affects the output clock accuracy in the freerun mode. The crystal specification is as follows.

*Frequency:* 20 MHz  
*Tolerance:* As required  
*Oscillation Mode:* Fundamental  
*Resonance Mode:* Parallel  
*Load Capacitance:* 32 pF  
*Maximum Series Resistance:* 35 Ω  
*Approximate Drive Level:* 1 mW  
 e.g., R1B23B32-20.0 MHz

(20 ppm absolute, ±6 ppm 0C to 50C, 32 pF, 25 Ω)

### 3.2 External Clock Oscillator

When an external clock oscillator is used, numerous parameters must be considered. This includes absolute frequency, frequency change over temperature, output rise and fall times, output levels and duty cycle.

For applications requiring  $\pm 32$  ppm clock accuracy, the following clock oscillator module may be used:

FOX F7C-2E3-20.0 MHz

Frequency: 20 MHz

Tolerance: 25 ppm 0C to 70C

Rise & Fall Time: 10 ns (0.33V 2.97V 15 pF)

Duty Cycle: 40% to 60%

The output clock should be connected directly (not AC coupled) to the XTALi input of the device, and the XTALo output should be left open as shown in Figure 32.

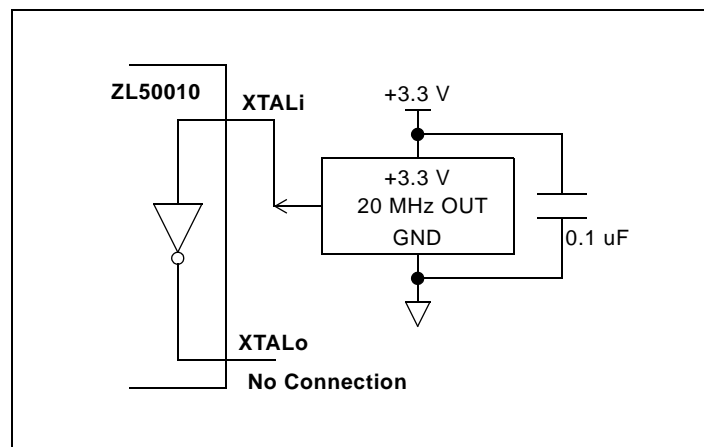

Figure 32 - External Clock Oscillator Circuit

## 4.0 Device Reset and Initialization

The  $\overline{\text{RESET}}$  pin is used to reset the device. When the pin is low, it synchronously puts the device into its reset state. It disables the STo0 - 15 outputs, drives the STOHz 0 - 15 outputs to high, clears the device registers and the internal counters.

Upon power up, the device should be initialized as follows:

- Set ODE pin to low to disable the STo0-15 output and to drive the STOHz 0-15 to high.
- Set the  $\overline{\text{TRST}}$  pin to low to disable the JTAG TAP controller.
- Reset the device by pulsing the  $\overline{\text{RESET}}$  pin to low for longer than 1 ms.
- After releasing the  $\overline{\text{RESET}}$  pin from low to high, wait for 600  $\mu\text{s}$  for the APLL module and the crystal oscillator to be stabilized before starting the first microprocessor port access cycle.
- Program the register to define the frequency of the  $\overline{\text{CKi}}$  input.
- Wait for 600  $\mu\text{s}$  for the APLL module to be stabilized before starting the next microprocessor port access cycle.
- Configure the DPLL. After a device reset, the DPLL defaults are: Master mode, failure detect mode is Autodetect, primary reference is PRI\_REF at 8 kHz, SEC\_REF frequency is 8 kHz, preferred reference is the primary reference, polarities of PRI\_REF and SEC\_REF are not inverted.
- If DPLL Master mode is selected, wait 50 seconds for the DPLL to synchronize to the reference.
- Use the memory block programming mode to initialize the connection memory.
- Release the ODE pin to high after the connection memory is programmed such that bus contention will not occur at the serial stream outputs STo0-15.

## 5.0 JTAG Support

The ZL50010 JTAG interface conforms to the Boundary-Scan IEEE1149.1 standard. The operation of the boundary-scan circuitry is controlled by an external Test Access Port (TAP) Controller.

### 5.1 Test Access Port (TAP)

The Test Access Port (TAP) accesses the ZL50010 test functions. It consists of 3 input pins and 1 output pin as follows:

- **Test Clock Input (TCK)** - TCK provides the clock for the test logic. The TCK does not interfere with any on-chip clock and thus remains independent in the functional mode. The TCK permits shifting of test data into or out of the Boundary-Scan register cells concurrently with the operation of the device and without interfering with the on-chip logic.
- **Test Mode Select Input (TMS)** - The TAP Controller uses the logic signals received at the TMS input to control test operations. The TMS signals are sampled at the rising edge of the TCK pulse. This pin is internally pulled to Vdd when it is not driven from an external source.
- **Test Data Input (TDi)** - Serial input data applied to this port is fed either into the instruction register or into a test data register, depending on the sequence previously applied to the TMS input. Both registers are described in a subsequent section. The received input data is sampled at the rising edge of TCK pulses. This pin is internally pulled to Vdd when it is not driven from an external source.
- **Test Data Output (TDO)** - Depending on the sequence previously applied to the TMS input, the contents of either the instruction register or data register are serially shifted out towards the TDO. The data out of the TDO is clocked on the falling edge of the TCK pulses. When no data is shifted through the boundary scan cells, the TDO driver is set to a high impedance state.
- **Test Reset (TRST)** - Resets the JTAG scan structure. This pin is internally pulled to Vdd when it is not driven from an external source.

## 5.2 Instruction Register

The ZL50010 uses the public instructions defined in the IEEE 1149.1 standard. The JTAG Interface contains a four-bit instruction register. Instructions are serially loaded into the instruction register from the TDI when the TAP Controller is in its shifted-IR state. These instructions are subsequently decoded to achieve two basic functions: to select the test data register that may operate while the instruction is current and to define the serial test data register path that is used to shift data between TDI and TDO during data register scanning.

## 5.3 Test Data Register

As specified in IEEE 1149.1, the ZL50010 JTAG Interface contains three test data registers:

- **The Boundary-Scan Register** - The Boundary-Scan register consists of a series of Boundary-Scan cells arranged to form a scan path around the boundary of the ZL50010 core logic.
- **The Bypass Register** - The Bypass register is a single stage shift register that provides a one-bit path from TDI to its TDO.
- **The Device Identification Register** - The JTAG device ID for the ZL50010 is 0C35A14B<sub>H</sub>.

Version<31:28>:	0000
Part No. <27:12>:	1100 0011 0101 1010
Manufacturer ID<11:1>:	0001 0100 101
LSB<0>:	1

## 5.4 BSDL

A BSDL (Boundary Scan Description Language) file is available from Zarlink Semiconductor to aid in the use of the IEEE 1149 test interface.

## 6.0 Register Address Mapping

External Address A11 - A0	CPU Access	Register
000 <sub>H</sub>	R/W	Control Register, CR
001 <sub>H</sub>	R/W	Internal Mode Selection, IMS
010 <sub>H</sub>	R/W	BER Start Receive Register, BSRR
011 <sub>H</sub>	R/W	BER Length Register, BLR
012 <sub>H</sub>	Read Only	BER Count Register, BCR
030 <sub>H</sub>	R/W	DPLL Operation Mode, DOM
031 <sub>H</sub>	R/W	DPLL Output Adjustment, DPOA
032 <sub>H</sub>	Read Only	DPLL House Keeping Register, DHKR
100 <sub>H</sub>	R/W	Stream0 Input Control Register, SICR0
101 <sub>H</sub>	R/W	Stream0 Input Delay Register, SIDR0
102 <sub>H</sub>	R/W	Stream1 Input Control Register, SICR1
103 <sub>H</sub>	R/W	Stream1 Input Delay Register, SIDR1
104 <sub>H</sub>	R/W	Stream2 Input Control Register, SICR2
105 <sub>H</sub>	R/W	Stream2 Input Delay Register, SIDR2
106 <sub>H</sub>	R/W	Stream3 Input Control Register, SICR3
107 <sub>H</sub>	R/W	Stream3 Input Delay Register, SIDR3
108 <sub>H</sub>	R/W	Stream4 Input Control Register, SICR4
109 <sub>H</sub>	R/W	Stream4 Input Delay Register, SIDR4
10A <sub>H</sub>	R/W	Stream5 Input Control Register, SICR5
10B <sub>H</sub>	R/W	Stream5 Input Delay Register, SIDR5
10C <sub>H</sub>	R/W	Stream6 Input Control Register, SICR6
10D <sub>H</sub>	R/W	Stream6 Input Delay Register, SIDR6
10E <sub>H</sub>	R/W	Stream7 Input Control Register, SICR7
10F <sub>H</sub>	R/W	Stream7 Input Delay Register, SIDR7
110 <sub>H</sub>	R/W	Stream8 Input Control Register, SICR8
111 <sub>H</sub>	R/W	Stream8 Input Delay Register, SIDR8
112 <sub>H</sub>	R/W	Stream9 Input Control Register, SICR9
113 <sub>H</sub>	R/W	Stream9 Input Delay Register, SIDR9
114 <sub>H</sub>	R/W	Stream10 Input Control Register, SICR10
115 <sub>H</sub>	R/W	Stream10 Input Delay Register, SIDR10
116 <sub>H</sub>	R/W	Stream11 Input Control Register, SICR11
117 <sub>H</sub>	R/W	Stream11 Input Delay Register, SIDR11
118 <sub>H</sub>	R/W	Stream12 Input Control Register, SICR12
119 <sub>H</sub>	R/W	Stream12 Input Delay Register, SIDR12
11A <sub>H</sub>	R/W	Stream13 Input Control Register, SICR13
11B <sub>H</sub>	R/W	Stream13 Input Delay Register, SIDR13
11C <sub>H</sub>	R/W	Stream14 Input Control Register, SICR14



External Address A11 - A0	CPU Access	Register
11D <sub>H</sub>	R/W	Stream14 Input Delay Register, SIDR14
11E <sub>H</sub>	R/W	Stream15 Input Control Register, SICR15
11F <sub>H</sub>	R/W	Stream15 Input Delay Register, SIDR15
200 <sub>H</sub>	R/W	Stream0 Output Control Register, SOCR0
201 <sub>H</sub>	R/W	Stream0 Output Delay Register, SOOR0
202 <sub>H</sub>	R/W	Stream1 Output Control Register, SOCR1
203 <sub>H</sub>	R/W	Stream1 Output Delay Register, SOOR1
204 <sub>H</sub>	R/W	Stream2 Output Control Register, SOCR2
205 <sub>H</sub>	R/W	Stream2 Output Delay Register, SOOR2
206 <sub>H</sub>	R/W	Stream3 Output Control Register, SOCR3
207 <sub>H</sub>	R/W	Stream3 Output Delay Register, SOOR3
208 <sub>H</sub>	R/W	Stream4 Output Control Register, SOCR4
209 <sub>H</sub>	R/W	Stream4 Output Delay Register, SOOR4
20A <sub>H</sub>	R/W	Stream5 Output Control Register, SOCR5
20B <sub>H</sub>	R/W	Stream5 Output Delay Register, SOOR5
20C <sub>H</sub>	R/W	Stream6 Output Control Register, SOCR6
20D <sub>H</sub>	R/W	Stream6 Output Delay Register, SOOR6
20E <sub>H</sub>	R/W	Stream7 Output Control Register, SOCR7
20F <sub>H</sub>	R/W	Stream7 Output Delay Register, SOOR7
210 <sub>H</sub>	R/W	Stream8 Output Control Register, SOCR8
211 <sub>H</sub>	R/W	Stream8 Output Delay Register, SOOR8
212 <sub>H</sub>	R/W	Stream9 Output Control Register, SOCR9
213 <sub>H</sub>	R/W	Stream9 Output Delay Register, SOOR9
214 <sub>H</sub>	R/W	Stream10 Output Control Register, SOCR10
215 <sub>H</sub>	R/W	Stream10 Output Delay Register, SOOR10
216 <sub>H</sub>	R/W	Stream11 Output Control Register, SOCR11
217 <sub>H</sub>	R/W	Stream11 Output Delay Register, SOOR11
218 <sub>H</sub>	R/W	Stream12 Output Control Register, SOCR12
219 <sub>H</sub>	R/W	Stream12 Output Delay Register, SOOR12
21A <sub>H</sub>	R/W	Stream13 Output Control Register, SOCR13
21B <sub>H</sub>	R/W	Stream13 Output Delay Register, SOOR13
21C <sub>H</sub>	R/W	Stream14 Output Control Register, SOCR14
21D <sub>H</sub>	R/W	Stream14 Output Delay Register, SOOR14
21E <sub>H</sub>	R/W	Stream15 Output Control Register, SOCR15
21F <sub>H</sub>	R/W	Stream15 Output Delay Register, SOOR15

**Table 16 - Address Map for Device Specific Registers**

## 7.0 Detail Register description

External Read/Write Address: 000 <sub>H</sub> Reset Value: 0000 <sub>H</sub>																															
15	14	13	12	11	10	9	8	7	6	5	4	3	2	1	0																
0	SLV	FBD EN	CKIN 2	CKIN 1	CKIN 0	CKFP 2	CKFP 1	CKFP 0	CBER	SBER	MBPE	OSB	MS2	MS1	MS0																
Bit	Name	Description																													
15	Unused	<b>Reserved.</b> In normal functional mode, these bits MUST be set to zero.																													
14	SLV	<b>DPLL Bypass Mode Enable.</b> When this bit is zero, the DPLL is in Master or Freerun mode. When this bit is high, the DPLL is in Bypass mode.																													
13	FBDEN	<b>Frame Boundary Determination Disable.</b> When this bit is low, the long term frame boundary determination mode is disabled. When it is high, the determination mode is enabled. Set this bit from low to high after waiting for 600 $\mu$ s upon device power up.																													
12 - 10	CKIN2-0	<b>Input ST Bus Clock (<math>\overline{\text{CKi}}</math>) and Frame Pulse (<math>\overline{\text{FPi}}</math>) Selection.</b>																													
		<table border="1"> <thead> <tr> <th>CKIN2 - 0</th><th><math>\overline{\text{FPi}}</math> Low Cycle</th><th><math>\overline{\text{CKi}}</math></th></tr> </thead> <tbody> <tr> <td>000</td><td>61 ns</td><td>16.384 MHz</td></tr> <tr> <td>001</td><td>122 ns</td><td>8.192 MHz</td></tr> <tr> <td>010</td><td>244 ns</td><td>4.096 MHz</td></tr> <tr> <td>011 - 111</td><td colspan="2">Reserved</td></tr> </tbody> </table>			CKIN2 - 0	$\overline{\text{FPi}}$ Low Cycle	$\overline{\text{CKi}}$	000	61 ns	16.384 MHz	001	122 ns	8.192 MHz	010	244 ns	4.096 MHz	011 - 111	Reserved													
CKIN2 - 0	$\overline{\text{FPi}}$ Low Cycle	$\overline{\text{CKi}}$																													
000	61 ns	16.384 MHz																													
001	122 ns	8.192 MHz																													
010	244 ns	4.096 MHz																													
011 - 111	Reserved																														
9	CKFP2	<b>Output ST Bus clock <math>\overline{\text{CKo2}}</math> and frame pulse <math>\overline{\text{FPo2}}</math> Selection.</b> When this bit is low, $\overline{\text{CKo2}}$ is 32.768 MHz clock and $\overline{\text{FPo2}}$ is 30 ns wide frame pulse When this bit is high, $\overline{\text{CKo2}}$ is 16.384 MHz clock and $\overline{\text{FPo2}}$ is 61 ns wide frame pulse																													
8	CKFP1	<b>Output ST Bus clock <math>\overline{\text{CKo1}}</math> and frame pulse <math>\overline{\text{FPo1}}</math> Selection.</b> When this bit is low, $\overline{\text{CKo1}}$ is 16.384 MHz clock and $\overline{\text{FPo1}}$ is 61 ns wide frame pulse When this bit is high, $\overline{\text{CKo1}}$ is 8.192 MHz clock and $\overline{\text{FPo1}}$ is 122 ns wide frame pulse																													
7	CKFP0	<b>Output ST Bus clock <math>\overline{\text{CKo0}}</math> and frame pulse <math>\overline{\text{FPo0}}</math> Selection.</b> When this bit is low, $\overline{\text{CKo0}}$ is 4.096 MHz clock and $\overline{\text{FPo0}}$ is 244 ns wide frame pulse When this bit is high, $\overline{\text{CKo0}}$ is 8.192 MHz clock and $\overline{\text{FPo0}}$ is 122 ns wide frame pulse																													
6	CBER	<b>Bit Error Rate Counter Clear:</b> When this bit is high, it resets the internal bit error counter and the content of the bit error count register (BCR) to zero. Upon completion of the reset, set this bit to zero.																													
5	SBER	<b>Bit Error Rate Test Start:</b> When this bit is high, it enables the BER transmitter and receiver; starts the bit error rate test. The bit error test result is kept in the bit error count (BCR) register. Upon the completion of the BER test, set this bit to zero.																													
4	MBPE	<b>Memory Block Programming Enable:</b> When this bit is high, the connection memory block programming mode is enabled to program Bit 0 to Bit 2 of the connection memory. When it is low, the memory block programming mode is disabled.																													

**Table 17 - Control Register (CR) Bits**

External Read/Write Address: 000 <sub>H</sub> Reset Value: 0000 <sub>H</sub>															
15	14	13	12	11	10	9	8	7	6	5	4	3	2	1	0
0	SLV	FBD EN	CKIN 2	CKIN 1	CKIN 0	CKFP 2	CKFP 1	CKFP 0	CBER	SBER	MBPE	OSB	MS2	MS1	MS0

Bit	Name	Description																									
3	OSB	<p><b>Output Stand By Bit:</b> This bit enables the STo0 - 15 and the STOHz 0 -15 serial outputs. The following table describes the HiZ control of the serial data outputs:</p> <table border="1" style="margin-left: auto; margin-right: auto; border-collapse: collapse;"> <thead> <tr> <th style="text-align: center;">RESET Pin</th> <th style="text-align: center;">ODE Pin</th> <th style="text-align: center;">OSB Bit</th> <th style="text-align: center;">STo0-15</th> <th style="text-align: center;">STOHz 0-15</th> </tr> </thead> <tbody> <tr> <td style="text-align: center;">0</td> <td style="text-align: center;">X</td> <td style="text-align: center;">X</td> <td style="text-align: center;">HiZ</td> <td style="text-align: center;">Driven High</td> </tr> <tr> <td style="text-align: center;">1</td> <td style="text-align: center;">0</td> <td style="text-align: center;">X</td> <td style="text-align: center;">HiZ</td> <td style="text-align: center;">Driven High</td> </tr> <tr> <td style="text-align: center;">1</td> <td style="text-align: center;">1</td> <td style="text-align: center;">0</td> <td style="text-align: center;">HiZ</td> <td style="text-align: center;">Driven High</td> </tr> <tr> <td style="text-align: center;">1</td> <td style="text-align: center;">1</td> <td style="text-align: center;">1</td> <td style="text-align: center;">Active</td> <td style="text-align: center;">Active</td> </tr> </tbody> </table>	RESET Pin	ODE Pin	OSB Bit	STo0-15	STOHz 0-15	0	X	X	HiZ	Driven High	1	0	X	HiZ	Driven High	1	1	0	HiZ	Driven High	1	1	1	Active	Active
RESET Pin	ODE Pin	OSB Bit	STo0-15	STOHz 0-15																							
0	X	X	HiZ	Driven High																							
1	0	X	HiZ	Driven High																							
1	1	0	HiZ	Driven High																							
1	1	1	Active	Active																							
2 - 0	MS2-0	<p><b>Memory Select Bit.</b> These bits are used to select connection memory or data memory:</p> <table border="1" style="margin-left: auto; margin-right: auto; border-collapse: collapse;"> <thead> <tr> <th style="text-align: center;">MS2 - 0</th> <th style="text-align: center;">Memory Selection</th> </tr> </thead> <tbody> <tr> <td style="text-align: center;">000</td> <td style="text-align: center;">Connection Memory Read/Write</td> </tr> <tr> <td style="text-align: center;">001</td> <td style="text-align: center;">Data memory Read</td> </tr> <tr> <td style="text-align: center;">010 - 111</td> <td style="text-align: center;">Reserved</td> </tr> </tbody> </table>	MS2 - 0	Memory Selection	000	Connection Memory Read/Write	001	Data memory Read	010 - 111	Reserved																	
MS2 - 0	Memory Selection																										
000	Connection Memory Read/Write																										
001	Data memory Read																										
010 - 111	Reserved																										

**Table 17 - Control Register (CR) Bits (continued)**

External Read/Write Address: 001 <sub>H</sub> Reset Value: 0000 <sub>H</sub>															
15	14	13	12	11	10	9	8	7	6	5	4	3	2	1	0
0	0	0	0	CKINP	FPINP	CK2P	FP2P	CK1P	FP1P	CK0P	FP0P	BPD 2	BPD 1	BPD 0	MBPS
Bit	Name	Description													
15 - 12	Unused	<b>Reserved.</b> In normal functional mode, these bits MUST be set to zero.													
11	CKINP	<b>ST Bus Clock Input (<math>\overline{\text{CKi}}</math>) Polarity</b> When this bit is low, the $\overline{\text{CKi}}$ falling edge aligns with the frame boundary. When this bit is high, the $\overline{\text{CKi}}$ rising edge aligns with the frame boundary.													
10	FPINP	<b>Frame Pulse Input (<math>\overline{\text{FPi}}</math>) Polarity</b> When this bit is low, the input frame pulse $\overline{\text{FPi}}$ should have the negative frame pulse format. When this bit is high, the input frame pulse $\overline{\text{FPi}}$ should have the positive frame pulse format.													
9	CK2P	<b>ST Bus Clock Output (<math>\overline{\text{CKo2}}</math>) Polarity</b> When this bit is low, the output clock $\overline{\text{CKo2}}$ falling edge aligns with the frame boundary. When this bit is high, the output clock $\overline{\text{CKo2}}$ rising edge aligns with the frame boundary.													
8	FP2P	<b>Frame Pulse Output (<math>\overline{\text{FPo2}}</math>) Polarity</b> When this bit is low, the output frame pulse $\overline{\text{FPo2}}$ has the negative frame pulse format. When this bit is high, the output frame pulse $\overline{\text{FPo2}}$ has the positive frame pulse format.													
7	CK1P	<b>ST Bus Clock Output (<math>\overline{\text{CKo1}}</math>) Polarity</b> When this bit is low, the output clock $\overline{\text{CKo1}}$ falling edge aligns with the frame boundary. When this bit is high, the output clock $\overline{\text{CKo1}}$ rising edge aligns with the frame boundary.													
6	FP1P	<b>Frame Pulse Output (<math>\overline{\text{FPo1}}</math>) Polarity</b> When this bit is low, the output frame pulse $\overline{\text{FPo1}}$ has the negative frame pulse format. When this bit is high, the output frame pulse $\overline{\text{FPo1}}$ has the positive frame pulse format.													
5	CK0P	<b>ST Bus Clock Output (<math>\overline{\text{CKo0}}</math>) Polarity</b> When this bit is low, the output clock $\overline{\text{CKo0}}$ falling edge aligns with the frame boundary. When this bit is high, the output clock $\overline{\text{CKo0}}$ rising edge aligns with the frame boundary.													
4	FP0P	<b>Frame Pulse Output (<math>\overline{\text{FPo0}}</math>) Polarity</b> When this bit is low, the output frame pulse $\overline{\text{FPo0}}$ has the negative frame pulse format. When this bit is high, the output frame pulse $\overline{\text{FPo0}}$ has the positive frame pulse format.													
3 - 1	BPD2 - 0	<b>Block Programming Data:</b> These bits refer to the value to be loaded into the connection memory. Whenever the memory block programming feature is activated. After the MBPE bit in the control register is set to high and the MBPS bit is set to high, the contents of the bits BPD0 to BPD2 are loaded into Bit 0 to Bit 2 of the connection memory. Bit 3 to Bit 11 of the connection memory are zeroed.													

Table 18 - Internal Mode Selection (IMS) Register Bits

External Read/Write Address: 001 <sub>H</sub> Reset Value: 0000 <sub>H</sub>															
15	14	13	12	11	10	9	8	7	6	5	4	3	2	1	0
0	0	0	0	CKINP	FPINP	CK2P	FP2P	CK1P	FP1P	CK0P	FP0P	BPD 2	BPD 1	BPD 0	MBPS
Bit	Name	Description													
0	MBPS	<p><b>Memory Block Programming Start:</b> A zero to one transition of this bit starts the memory block programming function. The MBPS, BPD0 to BPD2 bits in this register must be defined in the same write operation. Once the MBPE bit in the control register is set to high, the device requires 50 <math>\mu</math>s to complete the block programming. After the programming function has finished, the MBPS bit returns to low indicating the operation is completed. When the MBPS is high, the MBPS or MBPE can be set to low to abort the programming operation.</p> <p>To ensure proper block programming operation, when MBPS is high the BPD0 to BPD2 bits in this register must not be changed.</p> <p>Whenever the microprocessor writes a one to the MBPS bit, the block programming function is started, the user must maintain the same logical value to the other bits in this register to avoid any change in the device setting.</p>													

Table 18 - Internal Mode Selection (IMS) Register Bits (continued)

External Read/Write Address: 010 <sub>H</sub> Reset Value: 0000 <sub>H</sub>															
15	14	13	12	11	10	9	8	7	6	5	4	3	2	1	0
0	0	0	BR SA3	BR SA2	BR SA1	BR SA0	0	0	BR CA6	BR CA5	BR CA4	BR CA3	BR CA2	BR CA1	BR CA0
Bit	Name	Description													
15 - 13 8 - 7	Unused	<b>Reserved.</b> In normal functional mode, these bits MUST be set to zero.													
12 - 9	BRSA3 - 0	<b>BER Receive Stream Address Bits:</b> The binary value of these bits refers to the input stream which receives the BER data.													
6 - 0	BRCA6 - 0	<b>BER Receive Channel Address Bits:</b> The binary value of these bits refers to the input channel in which the BER data starts to be compared.													

Table 19 - BER Start Receiving Register (BSRR) Bits

External Read/Write Address: 011 <sub>H</sub> Reset Value: 0000H															
15	14	13	12	11	10	9	8	7	6	5	4	3	2	1	0
0	0	0	0	0	0	0	0	BL7	BL6	BL5	BL4	BL3	BL2	BL1	BL0
Bit	Name	Description													
15 - 8	Unused	<b>Reserved.</b> In normal functional mode, these bits MUST be set to zero.													
7 - 0	BL7 - 0	<b>BER Length Bits:</b> The binary value of these bits refers to the number of channels. The maximum numbers of BER channels are 32, 64 and 128 for the data rate of 2.048 Mbps, 4.096 Mbps and 8.192 Mbps modes respectively. The minimum number of BER channel is 1. If these bits are set to zero, no BER test will be performed.													

Table 20 - BER Length Register (BLR) Bits

External Read Address: 012 <sub>H</sub> Reset Value: 0000H															
15	14	13	12	11	10	9	8	7	6	5	4	3	2	1	0
BC 15	BC 14	BC 13	BC 12	BC 11	BC 10	BC 9	BC 8	BC 7	BC 6	BC 5	BC 4	BC 3	BC 2	BC 1	BC 0
Bit	Name	Description													
15 - 0	BC15 - 0	<b>BER Count Bits:</b> The binary value of these bits refers to the bit error counts. When it reaches its maximum value of Hex FFFF, the value will not be changed any more.													

Table 21 - BER Count Register (BCR) Bits

External Read/Write Address: 030 <sub>H</sub> Reset Value: 0000 <sub>H</sub>															
15	14	13	12	11	10	9	8	7	6	5	4	3	2	1	0
0	0	0	0	MRST	FDM1	FDM0	SINV	PINV	FS1	FS0	FP1	FP0	REF SEL	P_REF SEL	FREE RUN

Bit	Name	Description															
15 - 12	Unused	<b>Reserved.</b> In normal functional mode, these bits MUST be set to zero.															
11	MRST	<b>MTIE Reset Bit:</b> When MRST is low, the DPLL MTIE circuit is functional. When MRST is high, the MTIE circuit will be reset - the DPLL output will align with the nearest edge of the selected reference. (Note: After the realignment, the phase offset between the input reference and DPLL output is the amount programmed into the DPOA register.)															
10 - 9	FDM1 - 0	<p><b>Failure Detect Mode Bits:</b> These two bits are used to choose among one of three Failure Detection modes.</p> <table border="1" style="width:100%; border-collapse: collapse; margin-left: 20px;"> <thead> <tr> <th style="width:10%;">FDM1</th><th style="width:10%;">FDM0</th><th style="width:80%;">Failure Detection Mode</th></tr> </thead> <tbody> <tr> <td style="text-align: center;">0</td><td style="text-align: center;">0</td><td>Autodetect - Automatic Reference Re-arrangement based on reference monitor results and choice of preferred reference</td></tr> <tr> <td style="text-align: center;">0</td><td style="text-align: center;">1</td><td>Reserved</td></tr> <tr> <td style="text-align: center;">1</td><td style="text-align: center;">0</td><td>Forced Primary - The DPLL is forced to use primary reference only</td></tr> <tr> <td style="text-align: center;">1</td><td style="text-align: center;">1</td><td>Forced Secondary - The DPLL is forced to use secondary reference only</td></tr> </tbody> </table>	FDM1	FDM0	Failure Detection Mode	0	0	Autodetect - Automatic Reference Re-arrangement based on reference monitor results and choice of preferred reference	0	1	Reserved	1	0	Forced Primary - The DPLL is forced to use primary reference only	1	1	Forced Secondary - The DPLL is forced to use secondary reference only
FDM1	FDM0	Failure Detection Mode															
0	0	Autodetect - Automatic Reference Re-arrangement based on reference monitor results and choice of preferred reference															
0	1	Reserved															
1	0	Forced Primary - The DPLL is forced to use primary reference only															
1	1	Forced Secondary - The DPLL is forced to use secondary reference only															
8	SINV	<b>SEC_REF Input Inversion:</b> When this bit is low, the SEC_REF input will not be inverted. When this bit is high, the SEC_REF input will be inverted.															
7	PINV	<b>PRI_REF Input Inversion:</b> When this bit is low, the PRI_REF input will not be inverted. When this bit is high, the PRI_REF input will be inverted.															
6 - 5	FS1 - FS0	<p><b>SEC_REF Frequency Selection Bits:</b> These bits are used to specify the nominal clock frequency of the SEC_REF input.</p> <table border="1" style="width:100%; border-collapse: collapse; margin-left: 20px;"> <thead> <tr> <th style="width:10%;">FS1</th><th style="width:10%;">FS0</th><th style="width:80%;">Secondary Reference</th></tr> </thead> <tbody> <tr> <td style="text-align: center;">0</td><td style="text-align: center;">0</td><td style="text-align: center;">8 kHz</td></tr> <tr> <td style="text-align: center;">0</td><td style="text-align: center;">1</td><td style="text-align: center;">1.544 MHz</td></tr> <tr> <td style="text-align: center;">1</td><td style="text-align: center;">0</td><td style="text-align: center;">2.048 MHz</td></tr> <tr> <td style="text-align: center;">1</td><td style="text-align: center;">1</td><td style="text-align: center;">Reserved</td></tr> </tbody> </table>	FS1	FS0	Secondary Reference	0	0	8 kHz	0	1	1.544 MHz	1	0	2.048 MHz	1	1	Reserved
FS1	FS0	Secondary Reference															
0	0	8 kHz															
0	1	1.544 MHz															
1	0	2.048 MHz															
1	1	Reserved															

**Table 22 - DPLL Operation Mode (DOM) Register Bits**

External Read/Write Address: 030 <sub>H</sub> Reset Value: 0000 <sub>H</sub>																															
15	14	13	12	11	10	9	8	7	6	5	4	3	2	1	0																
0	0	0	0	MRST	FDM1	FDM0	SINV	PINV	FS1	FS0	FP1	FP0	REF SEL	P_REF SEL	FREE RUN																
Bit	Name	Description																													
4 - 3	FP1 - FP0	<p><b>PRI_REF Frequency Selection Bits:</b> These bits are used to specify the nominal clock frequency of the PRI_REF input.</p> <table border="1"> <thead> <tr> <th>FP1</th><th>FP0</th><th>Primary Reference</th></tr> </thead> <tbody> <tr> <td>0</td><td>0</td><td>8 kHz (PRI_REF or CKi/FPi)</td></tr> <tr> <td>0</td><td>1</td><td>1.544 MHz</td></tr> <tr> <td>1</td><td>0</td><td>2.048 MHz</td></tr> <tr> <td>1</td><td>1</td><td>Reserved</td></tr> </tbody> </table> <p>When the P_REFSEL bit is high to select the internal 8 kHz signal (derived from the FPi and CKi inputs) as primary reference, these bits must be set to 00.</p>															FP1	FP0	Primary Reference	0	0	8 kHz (PRI_REF or CKi/FPi)	0	1	1.544 MHz	1	0	2.048 MHz	1	1	Reserved
FP1	FP0	Primary Reference																													
0	0	8 kHz (PRI_REF or CKi/FPi)																													
0	1	1.544 MHz																													
1	0	2.048 MHz																													
1	1	Reserved																													
2	REFSEL	<p><b>Preferred Reference Selection Bit:</b> When this bit is low, the preferred reference is the <u>primary</u> reference selected via the P_REFSEL bit (PRI_REF or internal 8 kHz from FPi and CKi). When this bit is high, the preferred reference is the secondary reference (SEC_REF).</p>																													
1	P_REFSEL	<p><b>Primary Reference Source Selection Bit:</b> This bit is used to select the primary reference input to the DPLL from between 2 sources. When this bit is low, the primary reference is from the PRI_REF pin. <u>When this bit is high, the primary reference is from the internal 8 kHz generated from the FPi and CKi inputs. When this bit is high, the FP1-0 bits must be set to 00.</u></p> <p>If the internal 8 kHz signal is selected as the primary reference, the user must ensure that the FPi and CKi input signals will be re-applied after the internal 8 kHz signal is lost (or failed). If FPi or CKi is not presented to the device, the device cannot accept STi0-15 input data.</p>																													
0	FREERUN	<p><b>Freerun Control Bit:</b> When this bit is low and bit 14 of the Control Register is low, the DPLL is in Master mode. When this bit is high and bit 14 of the Control Register is low, the DPLL is in Freerun mode. This bit has no effect when bit 14 of the Control Register is high.</p>																													

Table 22 - DPLL Operation Mode (DOM) Register Bits (continued)



External Read/Write Address: 031 <sub>H</sub> Reset Value: 0000 <sub>H</sub>															
15	14	13	12	11	10	9	8	7	6	5	4	3	2	1	0
0	0	0	0	0	0	POS6	POS5	POS4	POS3	POS2	POS1	POS0	SKC2	SKC1	SKC0

Bit	Name	Description
15 - 10	Unused	<b>Reserved.</b> In normal functional mode, these bits MUST be set to zero.
9 - 3	POS6 - 0	<b>Phase Offset Bits:</b> These 7 bits form the 2's complement phase offset word which controls the DPLL output phase offset. The DPLL output is advanced (leads the reference) if the word is positive. The DPLL output is delayed (lags the reference) if the word is negative. The net effect is that the ST-BUS outputs will be advanced or delayed by the programmed amount. The offset is in step of 15.2 ns if the input reference is 8 kHz or 2.048 MHz. The offset is in step of 20.2 ns if the input reference is 1.544 MHz. These bits have no effect in Freerun or Bypass mode.
2 - 0	SKC2 - 0	<b>Skew Control Bits:</b> These 3 bits control the <u>delay</u> of the DPLL outputs from 0 to 13.3 ns in steps of 1.9 ns. The net effect is that the ST-BUS outputs will be delayed by the programmed amount. These bits have no effect in Freerun or Bypass mode.

Table 23 - DPLL Output Adjustment (DPOA) Register Bits

External Read Address: 032 <sub>H</sub> Reset Value: 0000 <sub>H</sub>															
15	14	13	12	11	10	9	8	7	6	5	4	3	2	1	0
0	0	0	0	0	0	0	0	0	0	SFD	PFD	LMT	ST2	ST1	ST0

Bit	Name	Description
15 - 6	Unused	<b>Reserved.</b> In normal functional mode, these bits MUST be set to zero.
5	SFD	<b>Secondary Fail Detection Bit (Read only bit):</b> This bit reports the validity of the SEC_REF signal. When the secondary reference fails, this bit is set to high.
4	PFD	<b>Primary Fail Detection Bit (Read only bit):</b> This bit reports the validity of the primary reference signal selected by the P_REFSEL bit in the DOM register. When the selected primary reference fails, this bit is set to high.
3	LMT	<b>DPLL LIMIT Bit (Read only bit):</b> This bit indicates that the Phase Slope Limiter is limiting the phase difference between the input reference and the feedback reference.
2 - 0	ST2 - 0	<b>DPLL State Bits (Read only bit):</b> These bits report the state of the DPLL state machine. The state numbers are shown in the bubbles in Figure 27 on page 37.

Table 24 - DPLL House Keeping (DHKR) Register Bits

External Read/Write Address: 100<sub>H</sub>, 102<sub>H</sub>, 104<sub>H</sub>, 106<sub>H</sub>, 108<sub>H</sub>, 10A<sub>H</sub>, 10C<sub>H</sub>, 10E<sub>H</sub>,  
Reset Value: 0000<sub>H</sub>

	15	14	13	12	11	10	9	8	7	6	5	4	3	2	1	0
SICR0	0	0	0	0	0	0	0	STIN0 QEN3	STIN0 QEN2	STIN0 QEN1	STIN0 QEN0	STIN0 SMP1	STIN0 SMP0	STIN0 DR2	STIN0 DR1	STIN0 DR0
SICR1	0	0	0	0	0	0	0	STIN1 QEN3	STIN1 QEN2	STIN1 QEN1	STIN1 QEN0	STIN1 SMP1	STIN1 SMP0	STIN1 DR2	STIN1 DR1	STIN1 DR0
SICR2	0	0	0	0	0	0	0	STIN2 QEN3	STIN2 QEN2	STIN2 QEN1	STIN2 QEN0	STIN2 SMP1	STIN2 SMP0	STIN2 DR2	STIN2 DR1	STIN2 DR0
SICR3	0	0	0	0	0	0	0	STIN3 QEN3	STIN3 QEN2	STIN3 QEN1	STIN3 QEN0	STIN3 SMP1	STIN3 SMP0	STIN3 DR2	STIN3 DR1	STIN3 DR0
SICR4	0	0	0	0	0	0	0	STIN4 QEN3	STIN4 QEN2	STIN4 QEN1	STIN4 QEN0	STIN4 SMP1	STIN4 SMP0	STIN4 DR2	STIN4 DR1	STIN4 DR0
SICR5	0	0	0	0	0	0	0	STIN5 QEN3	STIN5 QEN2	STIN5 QEN1	STIN5 QEN0	STIN5 SMP1	STIN5 SMP0	STIN5 DR2	STIN5 DR1	STIN5 DR0
SICR6	0	0	0	0	0	0	0	STIN6 QEN3	STIN6 QEN2	STIN6 QEN1	STIN6 QEN0	STIN6 SMP1	STIN6 SMP0	STIN6 DR2	STIN6 DR1	STIN6 DR0
SICR7	0	0	0	0	0	0	0	STIN7 QEN3	STIN7 QEN2	STIN7 QEN1	STIN7 QEN0	STIN7 SMP1	STIN7 SMP0	STIN7 DR2	STIN7 DR1	STIN7 DR0

Bit	Name	Description
15 - 9	Unused	<b>Reserved.</b> In normal functional mode, these bits MUST be set to zero.
8	STIN#QEN3	<b>Quadrant Frame 3 Enable.</b> When this bit is low, the device is in normal operation mode. When this bit is high, the LSB of every channel in this quadrant frame is replaced by "1". This quadrant frame is defined as Ch24 to 31, Ch48 to 63 and Ch96 to 127 for the 2.048 Mbps, 4.096 Mbps and 8.192 Mbps mode respectively.
7	STIN#QEN2	<b>Quadrant Frame 2 Enable.</b> When this bit is low, the device is in normal operation mode. When this bit is high, the LSB of every channel in this quadrant frame is replaced by "1". This quadrant frame is defined as Ch16 to 23, Ch32 to 47 and Ch64 to 95 for the 2.048 Mbps, 4.096 Mbps and 8.192 Mbps mode respectively.
6	STIN#QEN1	<b>Quadrant Frame 1 Enable.</b> When this bit is low, the device is in normal operation mode. When this bit is high, the LSB of every channel in this quadrant frame is replaced by "1". This quadrant frame is defined as Ch8 to 15, Ch16 to 31 and Ch32 to 63 for the 2.048 Mbps, 4.096 Mbps and 8.192 Mbps mode respectively.
5	STIN#QEN0	<b>Quadrant Frame 0 Enable.</b> When this bit is low, the device is in normal operation mode. When this bit is high, the LSB of every channel in this quadrant frame is replaced by "1". This quadrant frame is defined as Ch0 to 7, Ch0 to 15 and Ch0 to 31 for 2.048 Mbps, the 4.096 Mbps and 8.192 Mbps mode respectively.

**Table 25 - Stream Input Control Register 0 to 7 (SICR0 to SICR7)**

External Read/Write Address: 100<sub>H</sub>, 102<sub>H</sub>, 104<sub>H</sub>, 106<sub>H</sub>, 108<sub>H</sub>, 10A<sub>H</sub>, 10C<sub>H</sub>, 10E<sub>H</sub>,  
 Reset Value: 0000<sub>H</sub>

	15	14	13	12	11	10	9	8	7	6	5	4	3	2	1	0
SICR0	0	0	0	0	0	0	0	STIN0 QEN3	STIN0 QEN2	STIN0 QEN1	STIN0 QEN0	STIN0 SMP1	STIN0 SMP0	STIN0 DR2	STIN0 DR1	STIN0 DR0
SICR1	0	0	0	0	0	0	0	STIN1 QEN3	STIN1 QEN2	STIN1 QEN1	STIN1 QEN0	STIN1 SMP1	STIN1 SMP0	STIN1 DR2	STIN1 DR1	STIN1 DR0
SICR2	0	0	0	0	0	0	0	STIN2 QEN3	STIN2 QEN2	STIN2 QEN1	STIN2 QEN0	STIN2 SMP1	STIN2 SMP0	STIN2 DR2	STIN2 DR1	STIN2 DR0
SICR3	0	0	0	0	0	0	0	STIN3 QEN3	STIN3 QEN2	STIN3 QEN1	STIN3 QEN0	STIN3 SMP1	STIN3 SMP0	STIN3 DR2	STIN3 DR1	STIN3 DR0
SICR4	0	0	0	0	0	0	0	STIN4 QEN3	STIN4 QEN2	STIN4 QEN1	STIN4 QEN0	STIN4 SMP1	STIN4 SMP0	STIN4 DR2	STIN4 DR1	STIN4 DR0
SICR5	0	0	0	0	0	0	0	STIN5 QEN3	STIN5 QEN2	STIN5 QEN1	STIN5 QEN0	STIN5 SMP1	STIN5 SMP0	STIN5 DR2	STIN5 DR1	STIN5 DR0
SICR6	0	0	0	0	0	0	0	STIN6 QEN3	STIN6 QEN2	STIN6 QEN1	STIN6 QEN0	STIN6 SMP1	STIN6 SMP0	STIN6 DR2	STIN6 DR1	STIN6 DR0
SICR7	0	0	0	0	0	0	0	STIN7 QEN3	STIN7 QEN2	STIN7 QEN1	STIN7 QEN0	STIN7 SMP1	STIN7 SMP0	STIN7 DR2	STIN7 DR1	STIN7 DR0

Bit	Name	Description												
4 - 3	STIN#SMP1 - 0	<b>Input Data Sampling Point Selection Bits:</b> <table border="1" style="margin-left: 40px;"> <thead> <tr> <th>STIN#SMP1-0</th> <th>Sampling Point</th> </tr> </thead> <tbody> <tr> <td>00</td> <td>3/4 point</td> </tr> <tr> <td>01</td> <td>4/4 point</td> </tr> <tr> <td>10</td> <td>1/4 point</td> </tr> <tr> <td>11</td> <td>2/4 point</td> </tr> </tbody> </table>	STIN#SMP1-0	Sampling Point	00	3/4 point	01	4/4 point	10	1/4 point	11	2/4 point		
STIN#SMP1-0	Sampling Point													
00	3/4 point													
01	4/4 point													
10	1/4 point													
11	2/4 point													
2 - 0	STIN#DR2 - 0	<b>Input Data Rate Selection Bits:</b> <table border="1" style="margin-left: 40px;"> <thead> <tr> <th>STIN#DR2-0</th> <th>Data Rate</th> </tr> </thead> <tbody> <tr> <td>000</td> <td>Disabled - External pull-up or pull-down is required for ST-BUS input</td> </tr> <tr> <td>001</td> <td>2.048 Mbps</td> </tr> <tr> <td>010</td> <td>4.096 Mbps</td> </tr> <tr> <td>011</td> <td>8.192 Mbps</td> </tr> <tr> <td>100 - 111</td> <td>Reserved</td> </tr> </tbody> </table>	STIN#DR2-0	Data Rate	000	Disabled - External pull-up or pull-down is required for ST-BUS input	001	2.048 Mbps	010	4.096 Mbps	011	8.192 Mbps	100 - 111	Reserved
STIN#DR2-0	Data Rate													
000	Disabled - External pull-up or pull-down is required for ST-BUS input													
001	2.048 Mbps													
010	4.096 Mbps													
011	8.192 Mbps													
100 - 111	Reserved													

Note: # denotes input stream from 0 to 7

**Table 25 - Stream Input Control Register 0 to 7 (SICR0 to SICR7) (continued)**

External Read/Write Address: 110<sub>H</sub>, 112<sub>H</sub>, 114<sub>H</sub>, 116<sub>H</sub>, 118<sub>H</sub>, 11A<sub>H</sub>, 11C<sub>H</sub>, 11E<sub>H</sub>,  
Reset Value: 0000<sub>H</sub>

Bit	Name	Description
15		
14		
13		
12		
11		
10		
9		
8	STIN#QEN3	<b>Quadrant Frame 3 Enable.</b> When this bit is low, the device is in normal operation mode. When this bit is high, the LSB of every channel in this quadrant frame is replaced by "1". This quadrant frame is defined as Ch24 to 31, Ch48 to 63 and Ch96 to 127 for the 2.048 Mbps, 4.096 Mbps and 8.192 Mbps mode respectively.
7	STIN#QEN2	<b>Quadrant Frame 2 Enable.</b> When this bit is low, the device is in normal operation mode. When this bit is high, the LSB of every channel in this quadrant frame is replaced by "1". This quadrant frame is defined as Ch16 to 23, Ch32 to 47 and Ch64 to 95 for the 2.048 Mbps, 4.096 Mbps and 8.192 Mbps mode respectively.
6	STIN#QEN1	<b>Quadrant Frame 1 Enable.</b> When this bit is low, the device is in normal operation mode. When this bit is high, the LSB of every channel in this quadrant frame is replaced by "1". This quadrant frame is defined as Ch8 to 15, Ch16 to 31 and Ch32 to 63 for the 2.048 Mbps, 4.096 Mbps and 8.192 Mbps mode respectively.
5	STIN#QEN0	<b>Quadrant Frame 0 Enable.</b> When this bit is low, the device is in normal operation mode. When this bit is high, the LSB of every channel in this quadrant frame is replaced by "1". This quadrant frame is defined as Ch0 to 7, Ch0 to 15 and Ch0 to 31 for 2.048 Mbps, the 4.096 Mbps and 8.192 Mbps mode respectively.
4		
3		
2		
1		
0		
SICR8	0 0 0 0 0 0 0 0 STIN8 QEN3 STIN8 QEN2 STIN8 QEN1 STIN8 QEN0 STIN8 SMP1 STIN8 SMP0 STIN8 DR2 STIN8 DR1 STIN8 DR0	
SICR9	0 0 0 0 0 0 0 0 STIN9 QEN3 STIN9 QEN2 STIN9 QEN1 STIN9 QEN0 STIN9 SMP1 STIN9 SMP0 STIN9 DR2 STIN9 DR1 STIN9 DR0	
SICR10	0 0 0 0 0 0 0 0 STIN10 QEN3 STIN10 QEN2 STIN10 QEN1 STIN10 QEN0 STIN10 SMP1 STIN10 SMP0 STIN10 DR2 STIN10 DR1 STIN10 DR0	
SICR11	0 0 0 0 0 0 0 0 STIN11 QEN3 STIN11 QEN2 STIN11 QEN1 STIN11 QEN0 STIN11 SMP1 STIN11 SMP0 STIN11 DR2 STIN11 DR1 STIN11 DR0	
SICR12	0 0 0 0 0 0 0 0 STIN12 QEN3 STIN12 QEN2 STIN12 QEN1 STIN12 QEN0 STIN12 SMP1 STIN12 SMP0 STIN12 DR2 STIN12 DR1 STIN12 DR0	
SICR13	0 0 0 0 0 0 0 0 STIN13 QEN3 STIN13 QEN2 STIN13 QEN1 STIN13 QEN0 STIN13 SMP1 STIN13 SMP0 STIN13 DR2 STIN13 DR1 STIN13 DR0	
SICR14	0 0 0 0 0 0 0 0 STIN14 QEN3 STIN14 QEN2 STIN14 QEN1 STIN14 QEN0 STIN14 SMP1 STIN14 SMP0 STIN14 DR2 STIN14 DR1 STIN14 DR0	
SICR15	0 0 0 0 0 0 0 0 STIN15 QEN3 STIN15 QEN2 STIN15 QEN1 STIN15 QEN0 STIN15 SMP1 STIN15 SMP0 STIN15 DR2 STIN15 DR1 STIN15 DR0	

Table 26 - Stream Input Control Register 8 to 15 (SICR8 to SICR15)

External Read/Write Address: 110<sub>H</sub>, 112<sub>H</sub>, 114<sub>H</sub>, 116<sub>H</sub>, 118<sub>H</sub>, 11A<sub>H</sub>, 11C<sub>H</sub>, 11E<sub>H</sub>,  
 Reset Value: 0000<sub>H</sub>

	15	14	13	12	11	10	9	8	7	6	5	4	3	2	1	0
SICR8	0	0	0	0	0	0	0	STIN8 QEN3	STIN8 QEN2	STIN8 QEN1	STIN8 QEN0	STIN8 SMP1	STIN8 SMP0	STIN8 DR2	STIN8 DR1	STIN8 DR0
SICR9	0	0	0	0	0	0	0	STIN9 QEN3	STIN9 QEN2	STIN9 QEN1	STIN9 QEN0	STIN9 SMP1	STIN9 SMP0	STIN9 DR2	STIN9 DR1	STIN9 DR0
SICR10	0	0	0	0	0	0	0	STIN10 QEN3	STIN10 QEN2	STIN10 QEN1	STIN10 QEN0	STIN10 SMP1	STIN10 SMP0	STIN10 DR2	STIN10 DR1	STIN10 DR0
SICR11	0	0	0	0	0	0	0	STIN11 QEN3	STIN11 QEN2	STIN11 QEN1	STIN11 QEN0	STIN11 SMP1	STIN11 SMP0	STIN11 DR2	STIN11 DR1	STIN11 DR0
SICR12	0	0	0	0	0	0	0	STIN12 QEN3	STIN12 QEN2	STIN12 QEN1	STIN12 QEN0	STIN12 SMP1	STIN12 SMP0	STIN12 DR2	STIN12 DR1	STIN12 DR0
SICR13	0	0	0	0	0	0	0	STIN13 QEN3	STIN13 QEN2	STIN13 QEN1	STIN13 QEN0	STIN13 SMP1	STIN13 SMP0	STIN13 DR2	STIN13 DR1	STIN13 DR0
SICR14	0	0	0	0	0	0	0	STIN14 QEN3	STIN14 QEN2	STIN14 QEN1	STIN14 QEN0	STIN14 SMP1	STIN14 SMP0	STIN14 DR2	STIN14 DR1	STIN14 DR0
SICR15	0	0	0	0	0	0	0	STIN15 QEN3	STIN15 QEN2	STIN15 QEN1	STIN15 QEN0	STIN15 SMP1	STIN15 SMP0	STIN15 DR2	STIN15 DR1	STIN15 DR0

Bit	Name	Description												
4 - 3	STIN#SMP1 - 0	<b>Input Data Sampling Point Selection Bits:</b> <table border="1" style="margin-left: 40px;"> <thead> <tr> <th>STIN#SMP1-0</th> <th>Sampling Point</th> </tr> </thead> <tbody> <tr> <td>00</td> <td>3/4 point</td> </tr> <tr> <td>01</td> <td>4/4 point</td> </tr> <tr> <td>10</td> <td>1/4 point</td> </tr> <tr> <td>11</td> <td>2/4 point</td> </tr> </tbody> </table>	STIN#SMP1-0	Sampling Point	00	3/4 point	01	4/4 point	10	1/4 point	11	2/4 point		
STIN#SMP1-0	Sampling Point													
00	3/4 point													
01	4/4 point													
10	1/4 point													
11	2/4 point													
2 - 0	STIN#DR2 - 0	<b>Input Data Rate Selection Bits:</b> <table border="1" style="margin-left: 40px;"> <thead> <tr> <th>STIN#DR2-0</th> <th>Data Rate</th> </tr> </thead> <tbody> <tr> <td>000</td> <td>Disabled - External pull-up or pull-down is required for ST-BUS input</td> </tr> <tr> <td>001</td> <td>2.048 Mbps</td> </tr> <tr> <td>010</td> <td>4.096 Mbps</td> </tr> <tr> <td>011</td> <td>8.192 Mbps</td> </tr> <tr> <td>100 - 111</td> <td>Reserved</td> </tr> </tbody> </table>	STIN#DR2-0	Data Rate	000	Disabled - External pull-up or pull-down is required for ST-BUS input	001	2.048 Mbps	010	4.096 Mbps	011	8.192 Mbps	100 - 111	Reserved
STIN#DR2-0	Data Rate													
000	Disabled - External pull-up or pull-down is required for ST-BUS input													
001	2.048 Mbps													
010	4.096 Mbps													
011	8.192 Mbps													
100 - 111	Reserved													

Note: # denotes input stream from 8 to 15

**Table 26 - Stream Input Control Register 8 to 15 (SICR8 to SICR15) (continued)**

External Read/Write Address: 101<sub>H</sub>, 103<sub>H</sub>, 105<sub>H</sub>, 107<sub>H</sub>, 109<sub>H</sub>, 10B<sub>H</sub>, 10D<sub>H</sub>, 10F<sub>H</sub>,  
 Reset Value: 0000<sub>H</sub>

	15	14	13	12	11	10	9	8	7	6	5	4	3	2	1	0
SIDR0	0	0	0	0	0	0	STIN0 CD6	STIN0 CD5	STIN0 CD4	STIN0 CD3	STIN0 CD2	STIN0 CD1	STIN0 CD0	STIN0 BD2	STIN0 BD1	STIN0 BD0
SIDR1	0	0	0	0	0	0	STIN1 CD6	STIN1 CD5	STIN1 CD4	STIN1 CD3	STIN1 CD2	STIN1 CD1	STIN1 CD0	STIN1 BD2	STIN1 BD1	STIN1 BD0
SIDR2	0	0	0	0	0	0	STIN2 CD6	STIN2 CD5	STIN2 CD4	STIN2 CD3	STIN2 CD2	STIN2 CD1	STIN2 CD0	STIN2 BD2	STIN2 BD1	STIN2 BD0
SIDR3	0	0	0	0	0	0	STIN3 CD6	STIN3 CD5	STIN3 CD4	STIN3 CD3	STIN3 CD2	STIN3 CD1	STIN3 CD0	STIN3 BD2	STIN3 BD1	STIN3 BD0
SIDR4	0	0	0	0	0	0	STIN4 CD6	STIN4 CD5	STIN4 CD4	STIN4 CD3	STIN4 CD2	STIN4 CD1	STIN4 CD0	STIN4 BD2	STIN4 BD1	STIN4 BD0
SIDR5	0	0	0	0	0	0	STIN5 CD6	STIN5 CD5	STIN5 CD4	STIN5 CD3	STIN5 CD2	STIN5 CD1	STIN5 CD0	STIN5 BD2	STIN5 BD1	STIN5 BD0
SIDR6	0	0	0	0	0	0	STIN6 CD6	STIN6 CD5	STIN6 CD4	STIN6 CD3	STIN6 CD2	STIN6 CD1	STIN6 CD0	STIN6 BD2	STIN6 BD1	STIN6 BD0
SIDR7	0	0	0	0	0	0	STIN7 CD6	STIN7 CD5	STIN7 CD4	STIN7 CD3	STIN7 CD2	STIN7 CD1	STIN7 CD0	STIN7 BD2	STIN7 BD1	STIN7 BD0

Bit	Name	Description
15 - 10	Unused	<b>Reserved.</b> In normal functional mode, these bits MUST be set to zero.
9 - 3	STIN#CD6 - 0	<b>Input Stream# Channel Delay Bits:</b> The binary value of these bits refers to the number of channels that the input stream will be delayed. This value should not exceed the maximum channel number of the stream. Zero means no delay.
2 - 0	STIN#BD2 - 0	<b>Input Stream# Bit Delay Bits:</b> The binary value of these bits refers to the number of bits that the input stream will be delayed. This maximum value is 7. Zero means no delay.

Note: # denotes input stream from 0 to 7

**Table 27 - Stream Input Delay Register 0 to 7 (SIDR0 to SIDR7)**

External Read/Write Address: 111<sub>H</sub>, 113<sub>H</sub>, 115<sub>H</sub>, 117<sub>H</sub>, 119<sub>H</sub>, 11B<sub>H</sub>, 11D<sub>H</sub>, 11F<sub>H</sub>,  
 Reset Value: 0000<sub>H</sub>

	15	14	13	12	11	10	9	8	7	6	5	4	3	2	1	0
SIDR8	0	0	0	0	0	0	STIN8 CD6	STIN8 CD5	STIN8 CD4	STIN8 CD3	STIN8 CD2	STIN8 CD1	STIN8 CD0	STIN8B BD2	STIN8B BD1	STIN8B BD0
SIDR9	0	0	0	0	0	0	STIN9 CD6	STIN9 CD5	STIN9 CD4	STIN9 CD3	STIN9 CD2	STIN9 CD1	STIN9 CD0	STIN9B BD2	STIN9B BD1	STIN9B BD0
SIDR10	0	0	0	0	0	0	STIN10 CD6	STIN10 CD5	STIN10 CD4	STIN10 CD3	STIN10 CD2	STIN10 CD1	STIN10 CD0	STIN10 BD2	STIN10 BD1	STIN10 BD0
SIDR11	0	0	0	0	0	0	STIN11 CD6	STIN11 CD5	STIN11 CD4	STIN11 CD3	STIN11 CD2	STIN11 CD1	STIN11 CD0	STIN11 BD2	STIN11 BD1	STIN11 BD0
SIDR12	0	0	0	0	0	0	STIN12 CD6	STIN12 CD5	STIN12 CD4	STIN12 CD3	STIN12 CD2	STIN12 CD1	STIN12 CD0	STIN12 BD2	STIN12 BD1	STIN12 BD0
SIDR13	0	0	0	0	0	0	STIN13 CD6	STIN13 CD5	STIN13 CD4	STIN13 CD3	STIN13 CD2	STIN13 CD1	STIN13 CD0	STIN13 BD2	STIN13 BD1	STIN13 BD0
SIDR14	0	0	0	0	0	0	STIN14 CD6	STIN14 CD5	STIN14 CD4	STIN14 CD3	STIN14 CD2	STIN14 CD1	STIN14 CD0	STIN14 BD2	STIN14 BD1	STIN14 BD0
SIDR15	0	0	0	0	0	0	STIN15 CD6	STIN15 CD5	STIN15 CD4	STIN15 CD3	STIN15 CD2	STIN15 CD1	STIN15 CD0	STIN15 BD2	STIN15 BD1	STIN15 BD0

Bit	Name	Description
15 - 10	Unused	<b>Reserved.</b> In normal functional mode, these bits MUST be set to zero.
9 - 3	STIN#CD6 - 0	<b>Input Stream# Channel Delay Bits:</b> The binary value of these bits refers to the number of channels that the input stream will be delayed. This value should not exceed the maximum channel number of the stream. Zero means no delay.
2 - 0	STIN#BD2 - 0	<b>Input Stream# Bit Delay Bits:</b> The binary value of these bits refers to the number of bits that the input stream will be delayed. This maximum value is 7. Zero means no delay.

Note: # denotes input stream from 8 to 15

**Table 28 - Stream Input Delay Register 8 to 15 (SIDR8 to SIDR15)**

External Read/Write Address: 200<sub>H</sub>, 202<sub>H</sub>, 204<sub>H</sub>, 206<sub>H</sub>, 208<sub>H</sub>, 20A<sub>H</sub>, 20C<sub>H</sub>, 20E<sub>H</sub>,  
 Reset Value: 0000<sub>H</sub>

	15	14	13	12	11	10	9	8	7	6	5	4	3	2	1	0
SOCR0	0	0	0	0	0	0	0	0	0	STOHZ0 AC	STOHZ0 A2	STOHZ0 A1	STOHZ0 A0	STO0 DR2	STO0 DR1	STO0 DR0
SOCR1	0	0	0	0	0	0	0	0	0	STOHZ1 AC	STOHZ1 A2	STOHZ1 A1	STOHZ1 A0	STO1 DR2	STO1 DR1	STO1 DR0
SOCR2	0	0	0	0	0	0	0	0	0	STOHZ2 AC	STOHZ2 A2	STOHZ2 A1	STOHZ2 A0	STO2 DR2	STO2 DR1	STO2 DR0
SOCR3	0	0	0	0	0	0	0	0	0	STOHZ3 AC	STOHZ3 A2	STOHZ3 A1	STOHZ3 A0	STO3 DR2	STO3 DR1	STO3 DR0
SOCR4	0	0	0	0	0	0	0	0	0	STOHZ4 AC	STOHZ4 A2	STOHZ4 A1	STOHZ4 A0	STO4 DR2	STO4 DR1	STO4 DR0
SOCR5	0	0	0	0	0	0	0	0	0	STOHZ5 AC	STOHZ5 A2	STOHZ5 A1	STOHZ5 A0	STO5 DR2	STO5 DR1	STO5 DR0
SOCR6	0	0	0	0	0	0	0	0	0	STOHZ6 AC	STOHZ6 A2	STOHZ6 A1	STOHZ6 A0	STO6 DR2	STO6 DR1	STO6 DR0
SOCR7	0	0	0	0	0	0	0	0	0	STOHZ7 AC	STOHZ7 A2	STOHZ7 A1	STOHZ7 A0	STO7 DR2	STO7 DR1	STO7 DR0

Bit	Name	Description																					
15 - 7	Unused	<b>Reserved.</b> In normal functional mode, these bits <b>MUST</b> be set to zero.																					
6	STOHZ#AC	<b>STOHZ Advancement Control.</b> When this bit is low, the advancement unit is 15.2 ns. When this bit is high, the advancement unit is 1/4 bit.																					
5 - 3	STOHZ#A2 - 0	<b>STOHZ Additional Advancement Bits:</b> <table border="1" style="margin-left: 20px;"> <thead> <tr> <th>STOHZ#A2-0</th> <th>Additional Advancement (STOHZ#AC = 0)</th> <th>Additional Advancement (STOHZ#AC = 1)</th> </tr> </thead> <tbody> <tr> <td>000</td> <td>0.0 ns</td> <td>0 bit</td> </tr> <tr> <td>001</td> <td>15.2 ns</td> <td>1/4 bit</td> </tr> <tr> <td>010</td> <td>30.5 ns</td> <td>1/2 bit</td> </tr> <tr> <td>011</td> <td>45.7 ns</td> <td>3/4 bit</td> </tr> <tr> <td>100</td> <td>61.0 ns</td> <td>4/4 bit</td> </tr> <tr> <td>101-111</td> <td>Reserved</td> <td>Reserved</td> </tr> </tbody> </table>	STOHZ#A2-0	Additional Advancement (STOHZ#AC = 0)	Additional Advancement (STOHZ#AC = 1)	000	0.0 ns	0 bit	001	15.2 ns	1/4 bit	010	30.5 ns	1/2 bit	011	45.7 ns	3/4 bit	100	61.0 ns	4/4 bit	101-111	Reserved	Reserved
STOHZ#A2-0	Additional Advancement (STOHZ#AC = 0)	Additional Advancement (STOHZ#AC = 1)																					
000	0.0 ns	0 bit																					
001	15.2 ns	1/4 bit																					
010	30.5 ns	1/2 bit																					
011	45.7 ns	3/4 bit																					
100	61.0 ns	4/4 bit																					
101-111	Reserved	Reserved																					
2 - 0	STO#DR2 - 0	<b>Output Data Rate Selection Bits:</b> <table border="1" style="margin-left: 20px;"> <thead> <tr> <th>STO#DR2-0</th> <th>Output Data Rate</th> </tr> </thead> <tbody> <tr> <td>000</td> <td>STo HiZ STOHZ driven high</td> </tr> <tr> <td>001</td> <td>2.048 Mbps</td> </tr> <tr> <td>010</td> <td>4.096 Mbps</td> </tr> <tr> <td>011</td> <td>8.192 Mbps</td> </tr> <tr> <td>100 - 111</td> <td>Reserved</td> </tr> </tbody> </table>	STO#DR2-0	Output Data Rate	000	STo HiZ STOHZ driven high	001	2.048 Mbps	010	4.096 Mbps	011	8.192 Mbps	100 - 111	Reserved									
STO#DR2-0	Output Data Rate																						
000	STo HiZ STOHZ driven high																						
001	2.048 Mbps																						
010	4.096 Mbps																						
011	8.192 Mbps																						
100 - 111	Reserved																						

Note: # denotes input stream from 0 to 7

**Table 29 - Stream Output Control Register 0 to 7 (SOCR0 to SOCR7)**



External Read/Write Address: 210<sub>H</sub>, 212<sub>H</sub>, 214<sub>H</sub>, 216<sub>H</sub>, 218<sub>H</sub>, 21A<sub>H</sub>, 21C<sub>H</sub>, 21E<sub>H</sub>,  
 Reset Value: 0000<sub>H</sub>

	15	14	13	12	11	10	9	8	7	6	5	4	3	2	1	0
SOCR8	0	0	0	0	0	0	0	0	0	STOHZ8 AC	STOHZ8 A2	STOHZ8 A1	STOHZ8 A0	STO8 DR2	STO8 DR1	STO8 DR0
SOCR9	0	0	0	0	0	0	0	0	0	STOHZ9 AC	STOHZ9 A2	STOHZ9 A1	STOHZ9 A0	STO9 DR2	STO9 DR1	STO9 DR0
SOCR10	0	0	0	0	0	0	0	0	0	STOHZ10 AC	STOHZ10 A2	STOHZ10 A1	STOHZ10 A0	STO10 DR2	STO10 DR1	STO10 DR0
SOCR11	0	0	0	0	0	0	0	0	0	STOHZ11 AC	STOHZ11 A2	STOHZ11 A1	STOHZ11 A0	STO11 DR2	STO11 DR1	STO11 DR0
SOCR12	0	0	0	0	0	0	0	0	0	STOHZ12 AC	STOHZ12 A2	STOHZ12 A1	STOHZ12 A0	STO12 DR2	STO12 DR1	STO12 DR0
SOCR13	0	0	0	0	0	0	0	0	0	STOHZ13 AC	STOHZ13 A2	STOHZ13 A1	STOHZ13 A0	STO13 DR2	STO13 DR1	STO13 DR0
SOCR14	0	0	0	0	0	0	0	0	0	STOHZ14 AC	STOHZ14 A2	STOHZ14 A1	STOHZ14 A0	STO14 DR2	STO14 DR1	STO14 DR0
SOCR15	0	0	0	0	0	0	0	0	0	STOHZ15 AC	STOHZ15 A2	STOHZ15 A1	STOHZ15 A0	STO15 DR2	STO15 DR1	STO15 DR0

Bit	Name	Description																					
15 - 7	Unused	<b>Reserved.</b> In normal functional mode, these bits MUST be set to zero.																					
6	STOHZ#AC	<b>STOHZ Advancement Control.</b> When this bit is low, the advancement unit is 15.2 ns. When this bit is high, the advancement unit is 1/4 bit.																					
5 - 3	STOHZ#A2 - 0	<b>STOHZ Additional Advancement Bits:</b> <table border="1" style="margin-left: 20px;"> <thead> <tr> <th>STOHZ#A2-0</th> <th>Additional Advancement (STOHZ#AC = 0)</th> <th>Additional Advancement (STOHZ#AC = 1)</th> </tr> </thead> <tbody> <tr> <td>000</td> <td>0.0 ns</td> <td>0 bit</td> </tr> <tr> <td>001</td> <td>15.2 ns</td> <td>1/4 bit</td> </tr> <tr> <td>010</td> <td>30.5 ns</td> <td>1/2 bit</td> </tr> <tr> <td>011</td> <td>45.7 ns</td> <td>3/4 bit</td> </tr> <tr> <td>100</td> <td>61.0 ns</td> <td>4/4 bit</td> </tr> <tr> <td>101-111</td> <td>Reserved</td> <td>Reserved</td> </tr> </tbody> </table>	STOHZ#A2-0	Additional Advancement (STOHZ#AC = 0)	Additional Advancement (STOHZ#AC = 1)	000	0.0 ns	0 bit	001	15.2 ns	1/4 bit	010	30.5 ns	1/2 bit	011	45.7 ns	3/4 bit	100	61.0 ns	4/4 bit	101-111	Reserved	Reserved
STOHZ#A2-0	Additional Advancement (STOHZ#AC = 0)	Additional Advancement (STOHZ#AC = 1)																					
000	0.0 ns	0 bit																					
001	15.2 ns	1/4 bit																					
010	30.5 ns	1/2 bit																					
011	45.7 ns	3/4 bit																					
100	61.0 ns	4/4 bit																					
101-111	Reserved	Reserved																					
2 - 0	STO#DR2 - 0	<b>Output Data Rate Selection Bits:</b> <table border="1" style="margin-left: 20px;"> <thead> <tr> <th>STO#DR2-0</th> <th>Output Data Rate</th> </tr> </thead> <tbody> <tr> <td>000</td> <td>STo HiZ STOHZ driven high</td> </tr> <tr> <td>001</td> <td>2.048 Mbps</td> </tr> <tr> <td>010</td> <td>4.096 Mbps</td> </tr> <tr> <td>011</td> <td>8.192 Mbps</td> </tr> <tr> <td>100 - 111</td> <td>Reserved</td> </tr> </tbody> </table>	STO#DR2-0	Output Data Rate	000	STo HiZ STOHZ driven high	001	2.048 Mbps	010	4.096 Mbps	011	8.192 Mbps	100 - 111	Reserved									
STO#DR2-0	Output Data Rate																						
000	STo HiZ STOHZ driven high																						
001	2.048 Mbps																						
010	4.096 Mbps																						
011	8.192 Mbps																						
100 - 111	Reserved																						

Note: # denotes input stream from 8 to 15

**Table 30 - Stream Output Control Register 8 to 15 (SOCR8 to SOCR15)**

External Read/Write Address: 201<sub>H</sub>, 203<sub>H</sub>, 205<sub>H</sub>, 207<sub>H</sub>, 209<sub>H</sub>, 20B<sub>H</sub>, 20D<sub>H</sub>, 20F<sub>H</sub>,  
 Reset Value: 0000<sub>H</sub>

	15	14	13	12	11	10	9	8	7	6	5	4	3	2	1	0
SOOR0	0	0	0	0	STO0 CD6	STO0 CD5	STO0 CD4	STO0 CD3	STO0 CD2	STO0 CD1	STO0 CD0	STO0 BD2	STO0 BD1	STO0 BD0	STO0 FA1	STO0 FA0
SOOR1	0	0	0	0	STO1 CD6	STO1 CD5	STO1 CD4	STO1 CD3	STO1 CD2	STO1 CD1	STO1 CD0	STO1 BD2	STO1 BD1	STO1 BD0	STO1 FA1	STO1 FA0
SOOR2	0	0	0	0	STO2 CD6	STO2 CD5	STO2 CD4	STO2 CD3	STO2 CD2	STO2 CD1	STO2 CD0	STO2 BD2	STO2 BD1	STO2 BD0	STO2 FA1	STO2 FA0
SOOR3	0	0	0	0	STO3 CD6	STO3 CD5	STO3 CD4	STO3 CD3	STO3 CD2	STO3 CD1	STO3 CD0	STO3 BD2	STO3 BD1	STO3 BD0	STO3 FA1	STO3 FA0
SOOR4	0	0	0	0	STO4 CD6	STO4 CD5	STO4 CD4	STO4 CD3	STO4 CD2	STO4 CD1	STO4 CD0	STO4 BD2	STO4 BD1	STO4 BD0	STO4 FA1	STO4 FA0
SOOR5	0	0	0	0	STO5 CD6	STO5 CD5	STO5 CD4	STO5 CD3	STO5 CD2	STO5 CD1	STO5 CD0	STO5 BD2	STO5 BD1	STO5 BD0	STO5 FA1	STO5 FA0
SOOR6	0	0	0	0	STO6 CD6	STO6 CD5	STO6 CD4	STO6 CD3	STO6 CD2	STO6 CD1	STO6 CD0	STO6 BD2	STO6 BD1	STO6 BD0	STO6 FA1	STO6 FA0
SOOR7	0	0	0	0	STO7 CD6	STO7 CD5	STO7 CD4	STO7 CD3	STO7 CD2	STO7 CD1	STO7 CD0	STO7 BD2	STO7 BD1	STO7 BD0	STO7 FA1	STO7 FA0

Bit	Name	Description										
15 - 12	Unused	<b>Reserved.</b>										
11 - 5	STO#CD6-0	<b>Output Stream# Channel Delay Bits:</b> The binary value of these bits refers to the number of channels that the output stream is to be advanced. This value should not exceed the maximum channel number of the stream. Zero means no advancement.										
4 - 2	STO#BD2-0	<b>Output Stream# Bit Delay Selection Bits:</b> The binary value of these bits refers to the number of bits that the output stream is to be advanced. The maximum value is 7. Zero means no advancement.										
1 - 0	STO#FA1-0	<b>Output Stream# Fractional Advancement Bits</b> <table border="1" style="margin-left: auto; margin-right: auto;"> <thead> <tr> <th>STO#FA1-0</th> <th>Advanced By</th> </tr> </thead> <tbody> <tr> <td>00</td> <td>0</td> </tr> <tr> <td>01</td> <td>1/4 bit</td> </tr> <tr> <td>10</td> <td>2/4 bit</td> </tr> <tr> <td>11</td> <td>3/4 bit</td> </tr> </tbody> </table>	STO#FA1-0	Advanced By	00	0	01	1/4 bit	10	2/4 bit	11	3/4 bit
STO#FA1-0	Advanced By											
00	0											
01	1/4 bit											
10	2/4 bit											
11	3/4 bit											

Note: # denotes input stream from 0 to 7

**Table 31 - Stream Output Offset Register 0 to 7 (SOOR0 to SOOR7)**

External Read/Write Address: 211<sub>H</sub>, 213<sub>H</sub>, 215<sub>H</sub>, 217<sub>H</sub>, 219<sub>H</sub>, 21B<sub>H</sub>, 21D<sub>H</sub>, 21F<sub>H</sub>,  
 Reset Value: 0000<sub>H</sub>

	15	14	13	12	11	10	9	8	7	6	5	4	3	2	1	0
SOOR8	0	0	0	0	STO8CD6	STO8CD5	STO8CD4	STO8CD3	STO8CD2	STO8CD1	STO8CD0	STO8BD2	STO8BD1	STO8BD0	STO8FA1	STO8FA0
SOOR9	0	0	0	0	STO9CD6	STO9CD5	STO9CD4	STO9CD3	STO9CD2	STO9CD1	STO9CD0	STO9BD2	STO9BD1	STO9BD0	STO9FA1	STO9FA0
SOOR10	0	0	0	0	STO10CD6	STO10CD5	STO10CD4	STO10CD3	STO10CD2	STO10CD1	STO10CD0	STO10BD2	STO10BD1	STO10BD0	STO10FA1	STO10FA0
SOOR11	0	0	0	0	STO11CD6	STO11CD5	STO11CD4	STO11CD3	STO11CD2	STO11CD1	STO11CD0	STO11BD2	STO11BD1	STO11BD0	STO11FA1	STO11FA0
SOOR12	0	0	0	0	STO12CD6	STO12CD5	STO12CD4	STO12CD3	STO12CD2	STO12CD1	STO12CD0	STO12BD2	STO12BD1	STO12BD0	STO12FA1	STO12FA0
SOOR13	0	0	0	0	STO13CD6	STO13CD5	STO13CD4	STO13CD3	STO13CD2	STO13CD1	STO13CD0	STO13BD2	STO13BD1	STO13BD0	STO13FA1	STO13FA0
SOOR14	0	0	0	0	STO14CD6	STO14CD5	STO14CD4	STO14CD3	STO14CD2	STO14CD1	STO14CD0	STO14BD2	STO14BD1	STO14BD0	STO14FA1	STO14FA0
SOOR15	0	0	0	0	STO15CD6	STO15CD5	STO15CD4	STO15CD3	STO15CD2	STO15CD1	STO15CD0	STO15BD2	STO15BD1	STO15BD0	STO15FA1	STO15FA0

Bit	Name	Description										
15 - 12	Unused	<b>Reserved.</b>										
11 - 5	STO#CD6-0	<b>Output Stream# Channel Delay Bits:</b> The binary value of these bits refers to the number of channels that the output stream is to be advanced. This value should not exceed the maximum channel number of the stream. Zero means no advancement.										
4 - 2	STO#BD2-0	<b>Output Stream# Bit Delay Selection Bits:</b> The binary value of these bits refers to the number of bits that the output stream is to be advanced. The maximum value is 7. Zero means no advancement.										
1 - 0	STO#FA1-0	<b>Output Stream# Fractional Advancement Bits</b> <table border="1" style="margin-left: auto; margin-right: auto;"> <thead> <tr> <th>STO#FA1-0</th> <th>Advanced By</th> </tr> </thead> <tbody> <tr> <td>00</td> <td>0</td> </tr> <tr> <td>01</td> <td>1/4 bit</td> </tr> <tr> <td>10</td> <td>2/4 bit</td> </tr> <tr> <td>11</td> <td>3/4 bit</td> </tr> </tbody> </table>	STO#FA1-0	Advanced By	00	0	01	1/4 bit	10	2/4 bit	11	3/4 bit
STO#FA1-0	Advanced By											
00	0											
01	1/4 bit											
10	2/4 bit											
11	3/4 bit											

Note: # denotes input stream from 8 to 15

**Table 32 - Stream Output Offset Register 8 to 15 (SOOR8 to SOOR15)**

### 8.0 Memory Address Mappings

When A11 is high, the data or the connection memory can be accessed by the microprocessor port. The Bit 0 to Bit 2 in the control register determine the access to the data or connection memory

MSB (Note 1)	Stream Address (ST. 0-15)					Channel Address (Ch 0-127)							
External Address (A11)	A10	A9	A8	A7	Stream #	A6	A5	A4	A3	A2	A1	A0	Channel #
1	0	0	0	0	Stream 0	0	0	0	0	0	0	0	Ch 0
1	0	0	0	1	Stream 1	0	0	0	0	0	0	1	Ch 1
1	0	0	1	0	Stream 2	.	.	.	.	.	.	.	.
1	0	0	1	1	Stream 3	.	.	.	.	.	.	.	.
1	0	1	0	0	Stream 4	0	0	1	1	1	1	0	Ch 30
1	0	1	0	1	Stream 5	0	0	1	1	1	1	1	Ch 31 (Note 2)
1	0	1	1	0	Stream 6	0	1	0	0	0	0	0	Ch 32
1	0	1	1	1	Stream 7	0	1	0	0	0	0	1	Ch 33
1	0	1	0	0	Stream 8	.	.	.	.	.	.	.	.
.	.	.	.	.	.	.	.	.	.	.	.	.	.
.	.	.	.	.	.	0	1	1	1	1	1	0	Ch 62
.	.	.	.	.	.	0	1	1	1	1	1	1	Ch 63 (Note 3)
.	.	.	.	.	.	.	.	.	.	.	.	.	.
.	.	.	.	.	.	.	.	.	.	.	.	.	.
1	1	1	1	0	Stream 14	1	1	1	1	1	1	0	Ch 126
1	1	1	1	1	Stream 15	1	1	1	1	1	1	1	Ch 127 (Note 4)

Notes:  
 1. MSB of address must be high for access to data and connection memory positions. MSB must be low for access to registers.  
 2. Channels 0 to 31 are used when serial stream is at 2.048 Mbps.  
 3. Channels 0 to 63 are used when serial stream is at 4.096 Mbps.  
 4. Channels 0 to 127 are used when serial stream is at 8.192 Mbps.

**Table 33 - Address Map for Memory Locations (512x512 DX, MSB of address = 1)**

## 9.0 Connection Memory Bit Assignment

When the CMM bit (Bit0) is zero, the connection is in normal switching mode. When the CMM bit is one, the connection memory is in special transmission mode.

11 10 9 8 7 6 5 4 3 2 1 0																							
<table border="1"> <tr> <td>SSA3</td><td>SSA2</td><td>SSA1</td><td>SSA0</td><td>SCA6</td><td>SCA5</td><td>SCA4</td><td>SCA3</td><td>SCA2</td><td>SCA1</td><td>SCA0</td><td>CMM=0</td> </tr> </table>												SSA3	SSA2	SSA1	SSA0	SCA6	SCA5	SCA4	SCA3	SCA2	SCA1	SCA0	CMM=0
SSA3	SSA2	SSA1	SSA0	SCA6	SCA5	SCA4	SCA3	SCA2	SCA1	SCA0	CMM=0												
Bit	Name	Description																					
11 - 8	SSA3-0	<b>Source Stream Address.</b> The binary value of these 4 bits represents the input stream number.																					
7 - 1	SCA6-0	<b>Source Channel Address.</b> The binary value of these 7 bits represents the input channel number.																					
0	CMM=0	<b>Connection Memory Mode = 0.</b> If this bit is set low, the connection memory is in normal switching mode. Bit 1 to 11 represent the source stream number and channel number.																					

**Table 34 - Connection Memory Bit Assignment when the CMM bit = 0**

11 10 9 8 7 6 5 4 3 2 1 0																							
<table border="1"> <tr> <td>0</td><td>MSG7</td><td>MSG6</td><td>MSG5</td><td>MSG4</td><td>MSG3</td><td>MSG2</td><td>MSG1</td><td>MSG0</td><td>PCC1</td><td>PCC0</td><td>CMM=1</td> </tr> </table>												0	MSG7	MSG6	MSG5	MSG4	MSG3	MSG2	MSG1	MSG0	PCC1	PCC0	CMM=1
0	MSG7	MSG6	MSG5	MSG4	MSG3	MSG2	MSG1	MSG0	PCC1	PCC0	CMM=1												
Bit	Name	Description																					
11	Unused	<b>Reserved.</b>																					
10 - 3	MSG7-0	<b>Message Data Bits:</b> 8 bit data for the message mode.																					
2 - 1	PCC1-0	<b>Per-Channel Control Bits:</b> These two bits control outputs. <table border="1" style="margin-left: auto; margin-right: auto;"> <thead> <tr> <th>PCC</th><th>PCC0</th><th>Output</th></tr> </thead> <tbody> <tr> <td>0</td><td>0</td><td>Per Channel Tristate</td></tr> <tr> <td>0</td><td>1</td><td>Message Mode</td></tr> <tr> <td>1</td><td>0</td><td>BER Test Mode</td></tr> <tr> <td>1</td><td>1</td><td>Reserved</td></tr> </tbody> </table>	PCC	PCC0	Output	0	0	Per Channel Tristate	0	1	Message Mode	1	0	BER Test Mode	1	1	Reserved						
PCC	PCC0	Output																					
0	0	Per Channel Tristate																					
0	1	Message Mode																					
1	0	BER Test Mode																					
1	1	Reserved																					
0	CMM=1	<b>Connection Memory Mode = 1.</b> If this bit is set high, the connection memory is in the per-channel control mode which is per-channel tristate, per-channel message mode or per-channel BER mode.																					

**Table 35 - Connection Memory Bits Assignment when the CMM bit = 1**

**Absolute Maximum Ratings\***

	Parameter	Symbol	Min.	Max.	Units
1	I/O Supply Voltage	$V_{DD}$	-0.5	5.0	V
2	Input Voltage	$V_{I_{3V}}$	-0.5	$V_{DD} + 0.5$	V
3	Input Voltage (5 V tolerant inputs)	$V_{I_{5V}}$	-0.5	7.0	V
4	Continuous Current at digital outputs	$I_o$		15	mA
5	Package power dissipation	$P_D$		0.75	W
6	Storage temperature	$T_S$	- 55	+125	°C

\* Exceeding these values may cause permanent damage. Functional operation under these conditions is not implied.

**Recommended Operating Conditions -** Voltages are with respect to ground ( $V_{SS}$ ) unless otherwise stated.

	Characteristics	Sym.	Min.	Typ.†	Max.	Units
1	Operating Temperature	$T_{OP}$	-40	25	+85	°C
2	Positive Supply	$V_{DD}$	3.0	3.3	3.6	V
3	Input Voltage	$V_I$	0		$V_{DD}$	V
4	Input Voltage on 5 V Tolerant Inputs	$V_{I_{5V}}$	0		5.5	V

† Typical figures are at 25°C and are for design aid only: not guaranteed and not subject to production testing.

**DC Electrical Characteristics†** - Voltages are with respect to ground ( $V_{SS}$ ) unless otherwise stated.

	Characteristics	Sym.	Min.	Typ.†	Max.	Units	Test Conditions
1	Supply Current	$I_{DD}$			250	mA	Output unloaded
2	Input High Voltage	$V_{IH}$	2.0			V	
3	Input Low Voltage	$V_{IL}$			0.8	V	
4	Input Leakage (input pins) Input Leakage (bi-directional pins)	$I_{IL}$ $I_{BL}$			5 5	$\mu$ A $\mu$ A	$0 \leq V_{IN} \leq V_{DD\_IO}$ See Note 1
5	Weak Pullup Current	$I_{PU}$		-33		$\mu$ A	Input at 0 V
6	Weak Pulldown Current	$I_{PD}$		33		$\mu$ A	Input at $V_{DD\_IO}$
7	Input Pin Capacitance	$C_I$		3		pF	
8	Output High Voltage	$V_{OH}$	2.4			V	$I_{OH} = 10$ mA
9	Output Low Voltage	$V_{OL}$			0.4	V	$I_{OL} = 10$ mA
10	Output High Impedance Leakage	$I_{OZ}$			5	$\mu$ A	$0 < V < V_{DD}$
11	Output Pin Capacitance	$C_O$		5	10	pF	

† Characteristics are over recommended operating conditions unless otherwise stated.

‡ Typical figures are at 25°C,  $V_{DD}$  at 3.3 V and are for design aid only: not guaranteed and not subject to production testing.

\* Note 1: Maximum leakage on pins (output or I/O pins in high impedance state) is over an applied voltage ( $V_{IN}$ ).

**AC Electrical Characteristics<sup>†</sup> - Timing Parameter Measurement Voltage Levels**

	Characteristics	Sym.	Level	Units	Conditions
1	CMOS Threshold	$V_{CT}$	$0.5V_{DD\_IO}$	V	
2	Rise/Fall Threshold Voltage High	$V_{HM}$	$0.7V_{DD\_IO}$	V	
3	Rise/Fall Threshold Voltage Low	$V_{LM}$	$0.3V_{DD\_IO}$	V	

<sup>†</sup> Characteristics are over recommended operating conditions unless otherwise stated.

**AC Electrical Characteristics<sup>†</sup> -  $\overline{FPI}$  and  $\overline{CKI}$  Timing when CKIN2 to 0 bits = 000**

	Characteristic	Sym.	Min.	Typ. <sup>‡</sup>	Max.	Units	Notes
1	$\overline{FPI}$ Input Frame Pulse Width	$t_{FPIW}$	40	61	115	ns	
2	$\overline{FPI}$ Input Frame Pulse Setup Time	$t_{FPI S}$	20		40	ns	
3	$\overline{FPI}$ Input Frame Pulse Hold Time	$t_{FPI H}$	20		40	ns	
4	$\overline{CKI}$ Input Clock Period	$t_{CKIP}$	55	61	67	ns	
5	$\overline{CKI}$ Input Clock High Time	$t_{CKIH}$	27		33	ns	
6	$\overline{CKI}$ Input Clock Low Time	$t_{CKIL}$	27		33	ns	
7	$\overline{CKI}$ Input Clock Rise/Fall Time	$t_{rCKi}, t_{fCKi}$	0		3	ns	

<sup>†</sup> Characteristics are over recommended operating conditions unless otherwise stated.

<sup>‡</sup> Typical figures are at 25°C,  $V_{DD}$  at 3.3 V and are for design aid only: not guaranteed and not subject to production testing.

**AC Electrical Characteristics<sup>†</sup> -  $\overline{FPI}$  and  $\overline{CKI}$  Timing when CKIN2 to 0 bits = 001**

	Characteristic	Sym.	Min.	Typ. <sup>‡</sup>	Max.	Units	Notes
1	$\overline{FPI}$ Input Frame Pulse Width	$t_{FPIW}$	90	122	220	ns	
2	$\overline{FPI}$ Input Frame Pulse Setup Time	$t_{FPI S}$	45		90	ns	
3	$\overline{FPI}$ Input Frame Pulse Hold Time	$t_{FPI H}$	45		90	ns	
4	$\overline{CKI}$ Input Clock Period	$t_{CKIP}$	110	122	135	ns	
5	$\overline{CKI}$ Input Clock High Time	$t_{CKIH}$	63		69	ns	
6	$\overline{CKI}$ Input Clock Low Time	$t_{CKIL}$	63		69	ns	
7	$\overline{CKI}$ Input Clock Rise/Fall Time	$t_{rCKi}, t_{fCKi}$	0		3	ns	

<sup>†</sup> Characteristics are over recommended operating conditions unless otherwise stated.

<sup>‡</sup> Typical figures are at 25°C,  $V_{DD}$  at 3.3 V and are for design aid only: not guaranteed and not subject to production testing.

**AC Electrical Characteristics -  $\overline{FPI}$  and  $\overline{CKI}$  Timing when CKIN2 to 0 bits = 010**

	Characteristic	Sym.	Min.	Typ. <sup>‡</sup>	Max.	Units	Notes
1	$\overline{FPI}$ Input Frame Pulse Width	$t_{FPIW}$	90	244	420	ns	
2	$\overline{FPI}$ Input Frame Pulse Setup Time	$t_{FPI S}$	110		135	ns	
3	$\overline{FPI}$ Input Frame Pulse Hold Time	$t_{FPI H}$	120		145	ns	
4	$\overline{CKI}$ Input Clock Period	$t_{CKIP}$	220	244	270	ns	
5	$\overline{CKI}$ Input Clock High Time	$t_{CKIH}$	110		135	ns	
6	$\overline{CKI}$ Input Clock Low Time	$t_{CKIL}$	110		135	ns	
7	$\overline{CKI}$ Input Clock Rise/Fall Time	$t_{rCKi}, t_{fCKi}$	0		3	ns	

<sup>†</sup> Characteristics are over recommended operating conditions unless otherwise stated.

<sup>‡</sup> Typical figures are at 25°C,  $V_{DD}$  at 3.3 V and are for design aid only: not guaranteed and not subject to production testing.

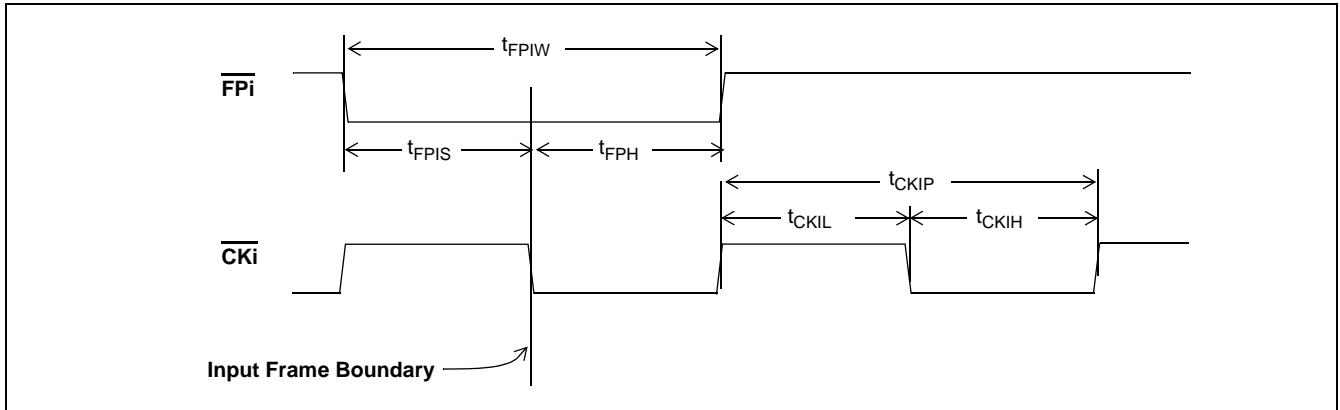

Figure 33 - Frame Pulse Input and Clock Input Timing Diagram

**AC Electrical Characteristics<sup>†</sup> - Frame Boundary Timing with Input Clock Cycle-to-cycle Variation**

	Characteristic	Sym.	Min.	Typ. <sup>‡</sup>	Max.	Units	Notes
1	CKi Input Clock cycle-to-cycle variation	$t_{\text{CKV}}$	0		50	ns	

<sup>†</sup> Characteristics are over recommended operating conditions unless otherwise stated.

<sup>‡</sup> Typical figures are at 25°C,  $V_{\text{DD}}$  at 3.3 V and are for design aid only: not guaranteed and not subject to production testing.

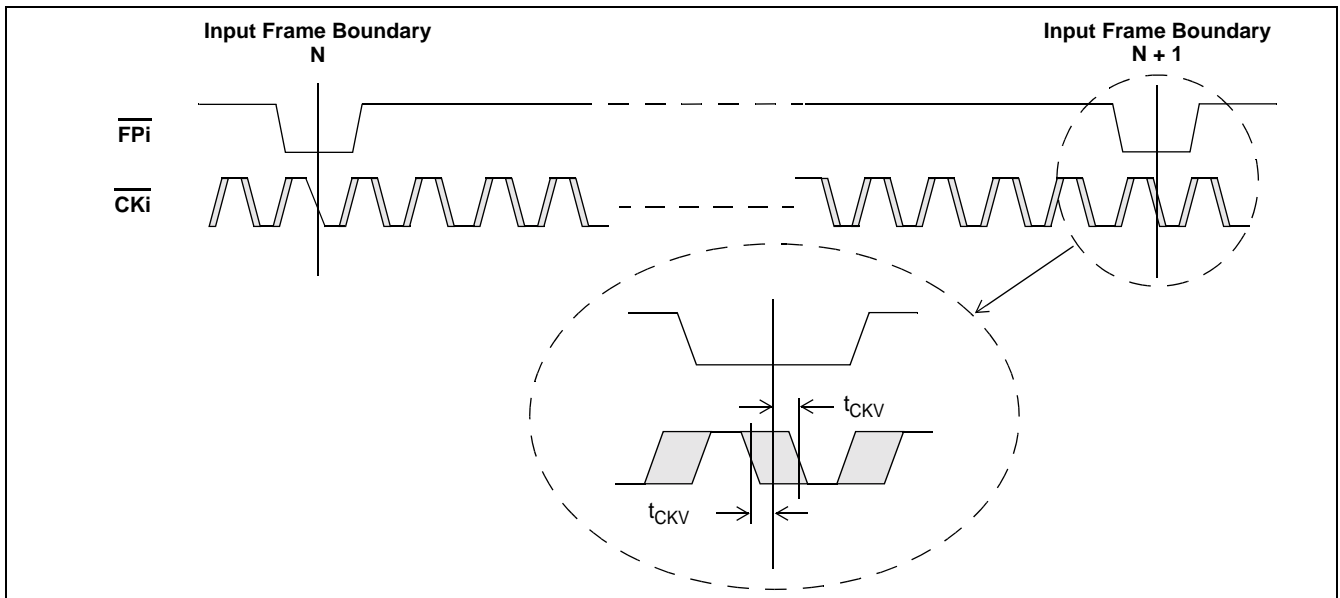

Figure 34 - Frame Boundary Timing with Input Clock (Cycle-to-Cycle) Variation



**AC Electrical Characteristics<sup>†</sup> - Frame Boundary Timing with Input Frame Pulse Cycle-to-cycle Variation**

	Characteristic	Sym.	Min.	Typ. <sup>‡</sup>	Max.	Units	Notes
1	FPI Input Frame Pulse cycle-to-cycle variation	$t_{FPV}$	0		50	ns	

<sup>†</sup> Characteristics are over recommended operating conditions unless otherwise stated.

<sup>‡</sup> Typical figures are at 25°C,  $V_{DD}$  at 3.3 V and are for design aid only: not guaranteed and not subject to production testing.

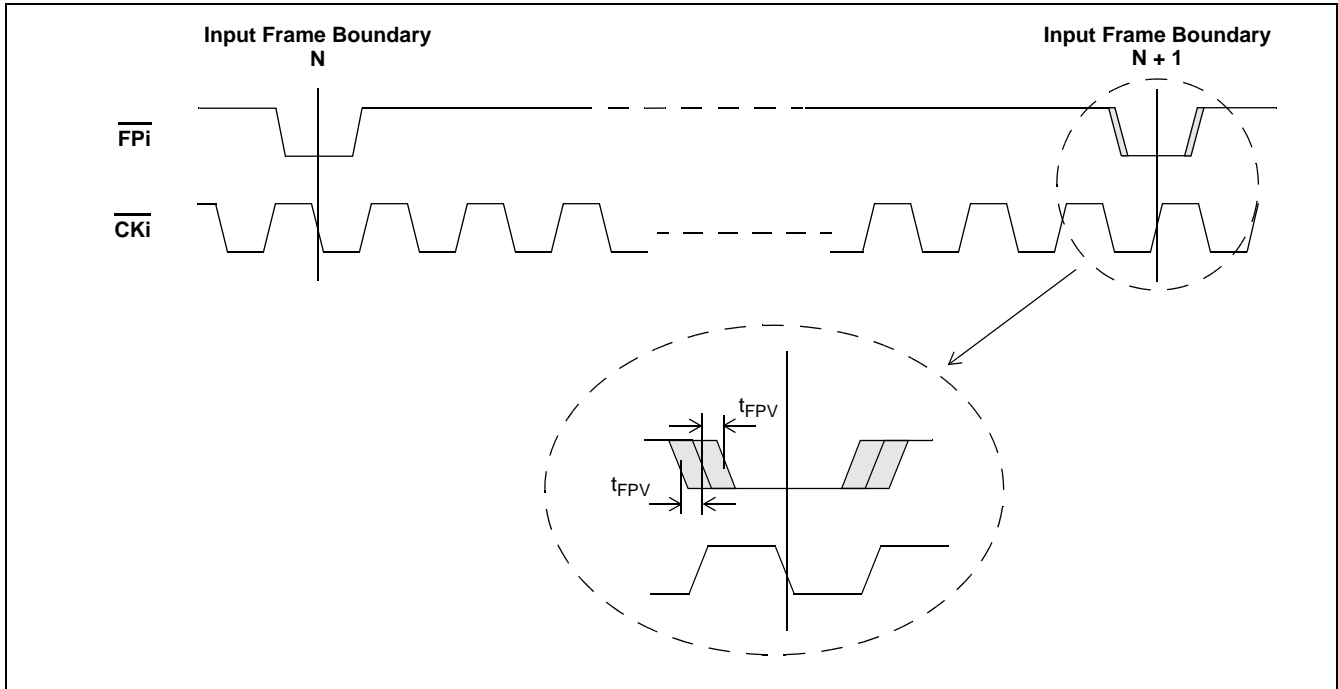

**Figure 35 - Frame Boundary Timing with Input Frame Pulse (Cycle-to-Cycle) Variation**

**AC Electrical Characteristics<sup>†</sup> - XTALi Input Timing when Clock Oscillator is connected**

	Characteristic	Sym.	Min.	Typ. <sup>‡</sup>	Max.	Units	Notes
1	C20i Input Clock Period	$t_{C20MP}$	49.995	50	50.005	ns	
2	C20i Input Clock High Time	$t_{C20MH}$	20		30	ns	
3	C20i Input Clock Low Time	$t_{C20ML}$	20		30	ns	
4	C20i Input Rise/Fall Time	$t_{rC20M}$ , $t_{fC20M}$		2		ns	

<sup>†</sup> Characteristics are over recommended operating conditions unless otherwise stated.

<sup>‡</sup> Typical figures are at 25°C,  $V_{DD}$  at 3.3 V and are for design aid only: not guaranteed and not subject to production testing.

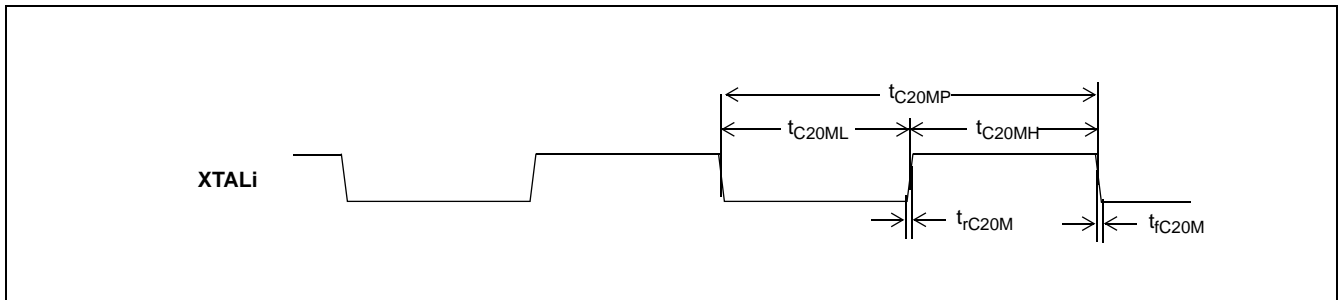

**Figure 36 - XTALi Input Timing Diagram when Clock Oscillator is Connected**

**AC Electrical Characteristics - Reference Input Timing**

	Characteristic	Sym.	Min.	Typ.	Max.	Units	Notes
1	PRI_REF, SEC_REF Period	$t_{R8KP}$	122	125	128	$\mu\text{s}$	8 kHz Mode
2	PRI_REF, SEC_REF High Time	$t_{R8KH}$	0.09		127.91	$\mu\text{s}$	
3	PRI_REF, SEC_REF Low Time	$t_{R8KL}$	0.09		127.91	$\mu\text{s}$	
4	PRI_REF, SEC_REF Rise/Fall Time	$t_{rR8K}, t_{fR8K}$	0		20	ns	
5	PRI_REF, SEC_REF Period	$t_{R2MP}$	370	488	605	ns	2.048 MHz Mode
6	PRI_REF, SEC_REF High Time	$t_{R2MH}$	90	244	515	ns	
7	PRI_REF, SEC_REF Low Time	$t_{R2ML}$	90	244	515	ns	
8	PRI_REF, SEC_REF Rise/Fall Time	$t_{rR2M}, t_{fR2M}$	0		20	ns	
9	PRI_REF, SEC_REF Period	$t_{R1M5P}$	490	648	805	ns	1.544 MHz Mode
10	PRI_REF, SEC_REF High Time	$t_{R1M5h}$	90	324	715	ns	
11	PRI_REF, SEC_REF Low Time	$t_{R1M5L}$	90	324	715	ns	
12	PRI_REF, SEC_REF Rise/Fall Time	$t_{rR1M5}, t_{fR1M5}$	0		20	ns	

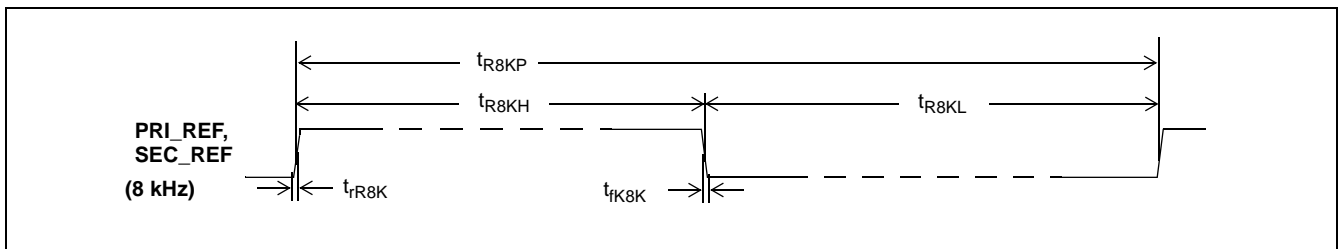

**Figure 37 - Reference Input Timing Diagram when the Input Frequency = 8 kHz**

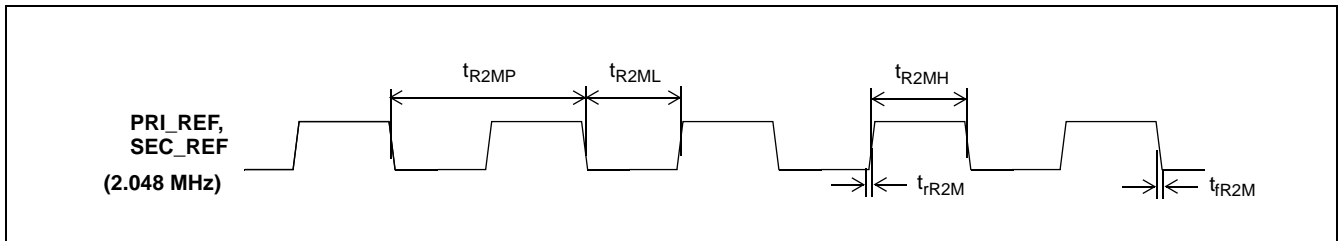

**Figure 38 - Reference Input Timing Diagram when the Input Frequency = 2.048 MHz**

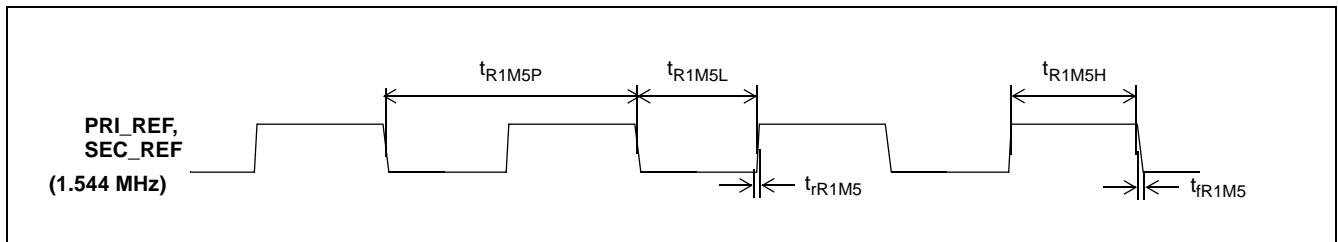

**Figure 39 - Reference Input Timing Diagram when the Input Frequency = 1.544 Hz**

**AC Electrical Characteristics - Input and Output Frame Boundary Alignment**

	Characteristic	Sym.	Min.	Typ	Max.	Units	Notes
1	Input and Output Frame Offset in DPLL Master Mode	$t_{FBOS}$	-20		0	ns	Input reference is internal 8 kHz derived from $\overline{FPI}$ and $\overline{CKi}$ . Measured when there is no jitter on the $\overline{CKi}$ and $\overline{FPI}$ inputs.
2	Input and Output Frame Offset in DPLL Bypass Mode	$t_{FBOS}$	1		18	ns	Measured when there is no jitter on the $\overline{CKi}$ and $\overline{FPI}$ inputs.

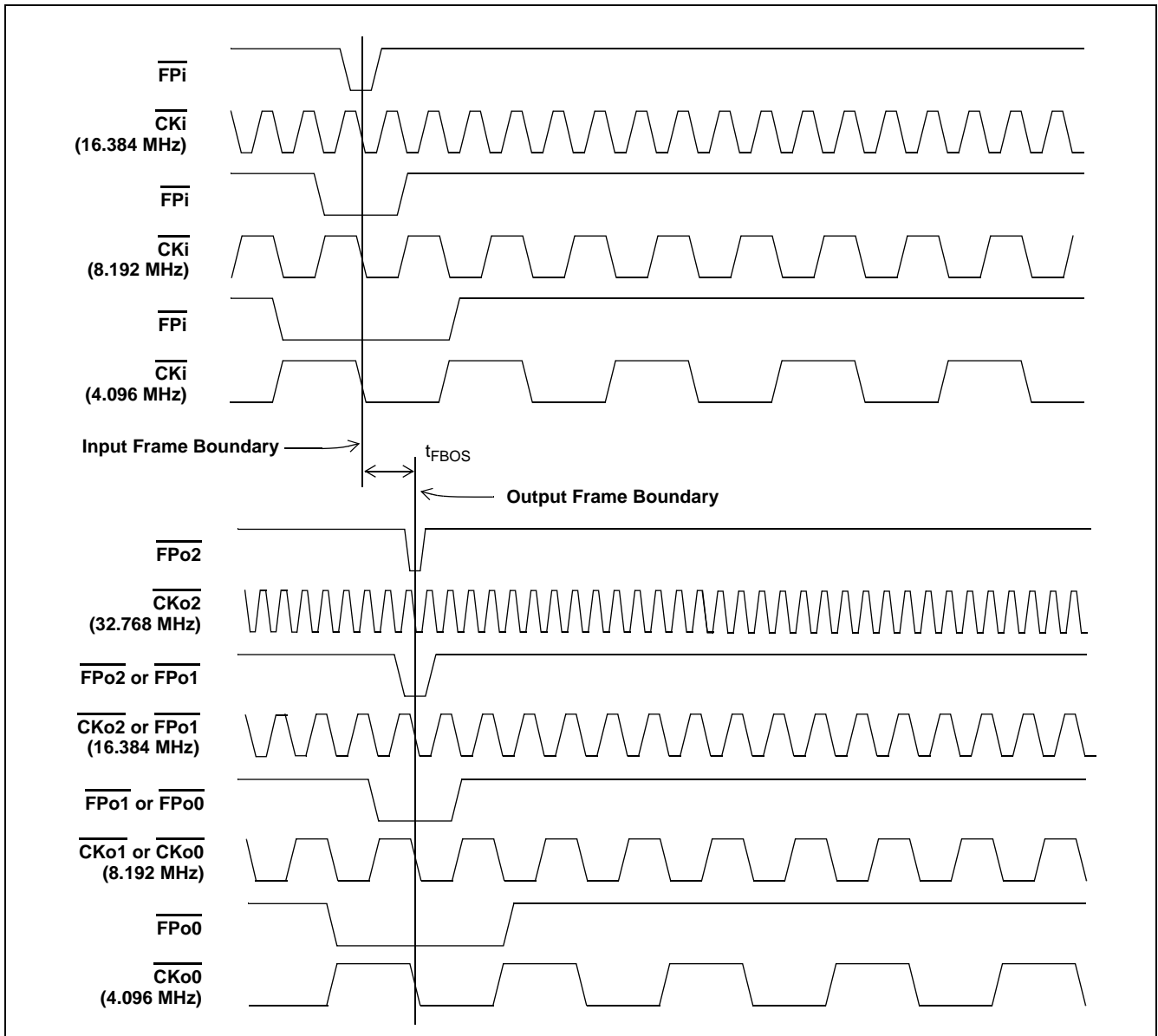

**Figure 40 - Input and Output Frame Boundary Offset**

**AC Electrical Characteristics<sup>†</sup> -  $\overline{\text{FPo0}}$  and  $\overline{\text{CKo0}}$  Timing when  $\text{CKFP0} = 0$** 

	Characteristic	Sym.	Min.	Typ. <sup>‡</sup>	Max.	Units	Notes
1	$\overline{\text{FPo0}}$ Output Pulse Width	$t_{\text{FPW0}}$	220	244	270	ns	$C_L=30\text{pF}$
2	$\overline{\text{FPo0}}$ Output Delay from the $\overline{\text{CKo0}}$ falling edge to the output frame boundary	$t_{\text{FODF0}}$	115		130	ns	
3	$\overline{\text{FPo0}}$ Output Delay from the output frame boundary to the $\overline{\text{CKo0}}$ Rising edge	$t_{\text{FODR0}}$	115		130	ns	
4	$\overline{\text{CKo0}}$ Output Clock Period	$t_{\text{CKP0}}$	220	244	270	ns	$C_L=30\text{pF}$
5	$\overline{\text{CKo0}}$ Output High Time	$t_{\text{CKH0}}$	115		130	ns	
6	$\overline{\text{CKo0}}$ Output Low Time	$t_{\text{CKL0}}$	115		130	ns	
7	$\overline{\text{CKo0}}$ Output Rise/Fall Time	$t_{\text{rCK0}}, t_{\text{fCK0}}$			10	ns	

<sup>†</sup> Characteristics are over recommended operating conditions unless otherwise stated.

<sup>‡</sup> Typical figures are at 25°C,  $V_{\text{DD}}$  at 3.3 V and are for design aid only: not guaranteed and not subject to production testing.

**AC Electrical Characteristics<sup>†</sup> -  $\overline{\text{FPo0}}$  and  $\overline{\text{CKo0}}$  Timing when  $\text{CKFP0} = 1$** 

	Characteristic	Sym.	Min.	Typ. <sup>‡</sup>	Max.	Units	Notes
1	$\overline{\text{FPo0}}$ Output Pulse Width	$t_{\text{FPW0}}$	108	122	140	ns	$C_L=30\text{ pF}$
2	$\overline{\text{FPo0}}$ Output Delay from the $\overline{\text{CKo0}}$ falling edge to the output frame boundary	$t_{\text{FODF0}}$	54		68	ns	
3	$\overline{\text{FPo0}}$ Output Delay from the output frame boundary to the $\overline{\text{CKo0}}$ Rising edge	$t_{\text{FODR0}}$	54		68	ns	
4	$\overline{\text{CKo0}}$ Output Clock Period	$t_{\text{CKP0}}$	108	122	140	ns	$C_L=30\text{ pF}$
5	$\overline{\text{CKo0}}$ Output High Time	$t_{\text{CKH0}}$	54		69	ns	
6	$\overline{\text{CKo0}}$ Output Low Time	$t_{\text{CKL0}}$	54		69	ns	
7	$\overline{\text{CKo0}}$ Output Rise/Fall Time	$t_{\text{rCK0}}, t_{\text{fCK0}}$			10	ns	

<sup>†</sup> Characteristics are over recommended operating conditions unless otherwise stated.

<sup>‡</sup> Typical figures are at 25°C,  $V_{\text{DD}}$  at 3.3 V and are for design aid only: not guaranteed and not subject to production testing.

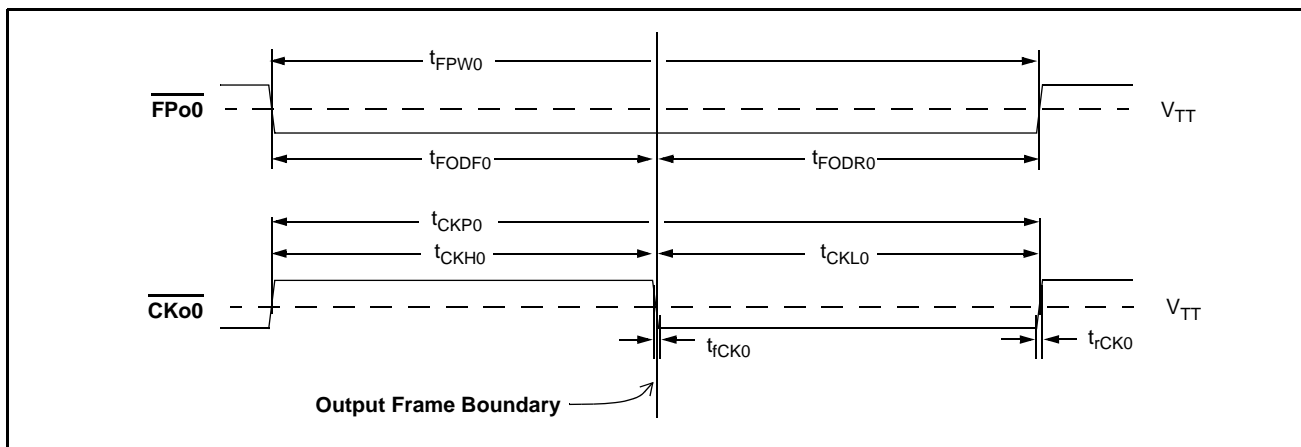

**Figure 41 -  $\overline{\text{FPo0}}$  and  $\overline{\text{CKo0}}$  Timing Diagram**

**AC Electrical Characteristics† -  $\overline{\text{FPo1}}$  and  $\overline{\text{CKo1}}$  Timing when CKFP1 = 0**

	Characteristic	Sym.	Min.	Typ.‡	Max.	Units	Notes
1	$\overline{\text{FPo1}}$ Output Pulse Width	$t_{\text{FPW1}}$	47	61	75	ns	$C_L=30$ pF
2	$\overline{\text{FPo1}}$ Output Delay from the $\overline{\text{CKo1}}$ falling edge to the output frame boundary	$t_{\text{FODF1}}$	20		40	ns	
3	$\overline{\text{FPo1}}$ Output Delay from the output frame boundary to the $\overline{\text{CKo1}}$ Rising edge	$t_{\text{FODR1}}$	20		40	ns	
4	$\overline{\text{CKo1}}$ Output Clock Period	$t_{\text{CKP1}}$	47	61	75	ns	$C_L=30$ pF
5	$\overline{\text{CKo1}}$ Output High Time	$t_{\text{CKH1}}$	20		40	ns	
6	$\overline{\text{CKo1}}$ Output Low Time	$t_{\text{CKL1}}$	20		40	ns	
7	$\overline{\text{CKo1}}$ Output Rise/Fall Time	$t_{\text{rCK1}}, t_{\text{fCK1}}$			10	ns	

† Characteristics are over recommended operating conditions unless otherwise stated.

‡ Typical figures are at 25°C,  $V_{\text{DD}}$  at 3.3 V and are for design aid only: not guaranteed and not subject to production testing.

**AC Electrical Characteristics† -  $\overline{\text{FPo1}}$  and  $\overline{\text{CKo1}}$  Timing when CKFP1 = 1**

	Characteristic	Sym.	Min.	Typ.‡	Max.	Units	Notes
1	$\overline{\text{FPo1}}$ Output Pulse Width	$t_{\text{FPW1}}$	108	122	140	ns	$C_L=30$ pF
2	$\overline{\text{FPo1}}$ Output Delay from the $\overline{\text{CKo1}}$ falling edge to the output frame boundary	$t_{\text{FODF1}}$	54		68	ns	
3	$\overline{\text{FPo1}}$ Output Delay from the output frame boundary to the $\overline{\text{CKo1}}$ Rising edge	$t_{\text{FODR1}}$	54		68	ns	
4	$\overline{\text{CKo1}}$ Output Clock Period	$t_{\text{CKP1}}$	108	122	140	ns	$C_L=30$ pF
5	$\overline{\text{CKo1}}$ Output High Time	$t_{\text{CKH1}}$	54		69	ns	
6	$\overline{\text{CKo1}}$ Output Low Time	$t_{\text{CKL1}}$	54		69	ns	
7	$\overline{\text{CKo1}}$ Output Rise/Fall Time	$t_{\text{rCK1}}, t_{\text{fCK1}}$			10	ns	

† Characteristics are over recommended operating conditions unless otherwise stated.

‡ Typical figures are at 25°C,  $V_{\text{DD}}$  at 3.3 V and are for design aid only: not guaranteed and not subject to production testing.

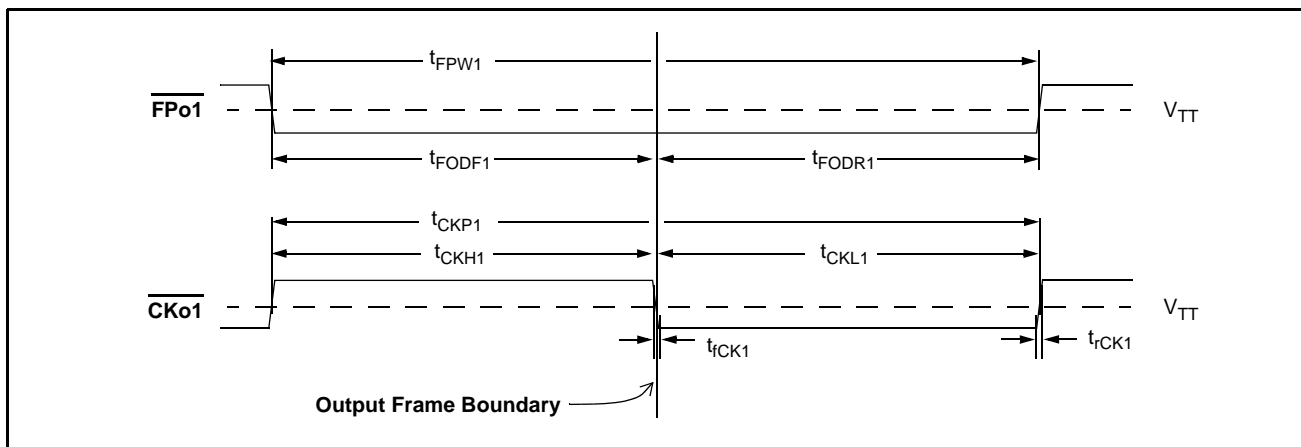

**Figure 42 -  $\overline{\text{FPo1}}$  and  $\overline{\text{CKo1}}$  Timing Diagram**

**AC Electrical Characteristics† -  $\overline{\text{FPo2}}$  and  $\overline{\text{CKo2}}$  Timing when CKFP2 = 0**

	Characteristic	Sym.	Min.	Typ.‡	Max.	Units	Notes
1	$\overline{\text{FPo2}}$ Output Pulse Width	$t_{\text{FPW2}}$	15	30	45	ns	$C_L=30$ pF
2	$\overline{\text{FPo2}}$ Output Delay from the $\overline{\text{CKo2}}$ falling edge to the output frame boundary	$t_{\text{FODF2}}$	8		22	ns	
3	$\overline{\text{FPo2}}$ Output Delay from the output frame boundary to the $\overline{\text{CKo2}}$ Rising edge	$t_{\text{FODR2}}$	8		22	ns	
4	$\overline{\text{CKo2}}$ Output Clock Period	$t_{\text{CKP2}}$	15	30	45	ns	$C_L=30$ pF
5	$\overline{\text{CKo2}}$ Output High Time	$t_{\text{CKH2}}$	8		22	ns	
6	$\overline{\text{CKo2}}$ Output Low Time	$t_{\text{CKL2}}$	8		22	ns	
7	$\overline{\text{CKo2}}$ Output Rise/Fall Time	$t_{\text{rCK2}}, t_{\text{fCK2}}$			7	ns	

† Characteristics are over recommended operating conditions unless otherwise stated.

‡ Typical figures are at 25°C,  $V_{\text{DD}}$  at 3.3 V and are for design aid only: not guaranteed and not subject to production testing.

**AC Electrical Characteristics† -  $\overline{\text{FPo2}}$  and  $\overline{\text{CKo2}}$  Timing when CKFP2 = 1**

	Characteristic	Sym.	Min.	Typ.‡	Max.	Units	Notes
1	$\overline{\text{FPo2}}$ Output Pulse Width	$t_{\text{FPW2}}$	47	61	75	ns	$C_L=30$ pF
2	$\overline{\text{FPo2}}$ Output Delay from the $\overline{\text{CKo2}}$ falling edge to the output frame boundary	$t_{\text{FODF2}}$	20		40	ns	
3	$\overline{\text{FPo2}}$ Output Delay from the output frame boundary to the $\overline{\text{CKo2}}$ Rising edge	$t_{\text{FODR2}}$	20		40	ns	
4	$\overline{\text{CKo2}}$ Output Clock Period	$t_{\text{CKP2}}$	47	61	75	ns	$C_L=30$ pF
5	$\overline{\text{CKo2}}$ Output High Time	$t_{\text{CKH2}}$	20		40	ns	
6	$\overline{\text{CKo2}}$ Output Low Time	$t_{\text{CKL2}}$	20		40	ns	
7	$\overline{\text{CKo2}}$ Output Rise/Fall Time	$t_{\text{rCK2}}, t_{\text{fCK2}}$			10	ns	

† Characteristics are over recommended operating conditions unless otherwise stated.

‡ Typical figures are at 25°C,  $V_{\text{DD}}$  at 3.3 V and are for design aid only: not guaranteed and not subject to production testing.

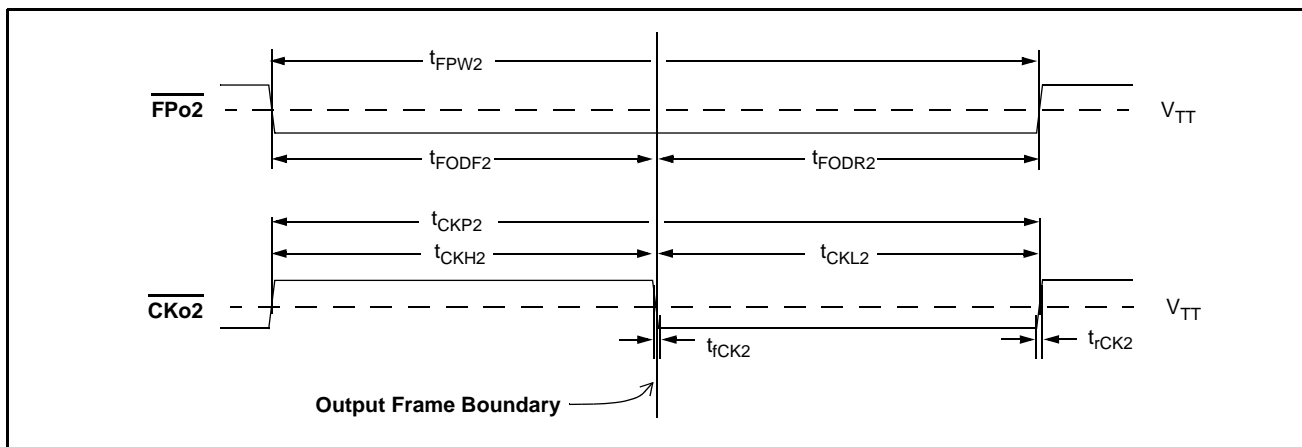

**Figure 43 -  $\overline{\text{FPo2}}$  and  $\overline{\text{CKo2}}$  Timing Diagram**

**AC Electrical Characteristics<sup>†</sup> - ST-BUS Input Timing**

	Characteristic	Sym.	Min.	Typ. <sup>‡</sup>	Max.	Units	Test Conditions
1	STi Setup Time						
	2.048 Mbps	$t_{SIS2}$	3			ns	
	4.096 Mbps	$t_{SIS4}$	3			ns	
	8.192 Mbps	$t_{SIS8}$	3			ns	
2	STi Hold Time						
	2.048 Mbps	$t_{SIH2}$	3			ns	
	4.096 Mbps	$t_{SIH4}$	3			ns	
	8.192 Mbps	$t_{SIH8}$	3			ns	

<sup>†</sup> Characteristics are over recommended operating conditions unless otherwise stated.

<sup>‡</sup> Typical figures are at 25°C,  $V_{DD}$  at 3.3 V and are for design aid only; not guaranteed and not subject to production testing.

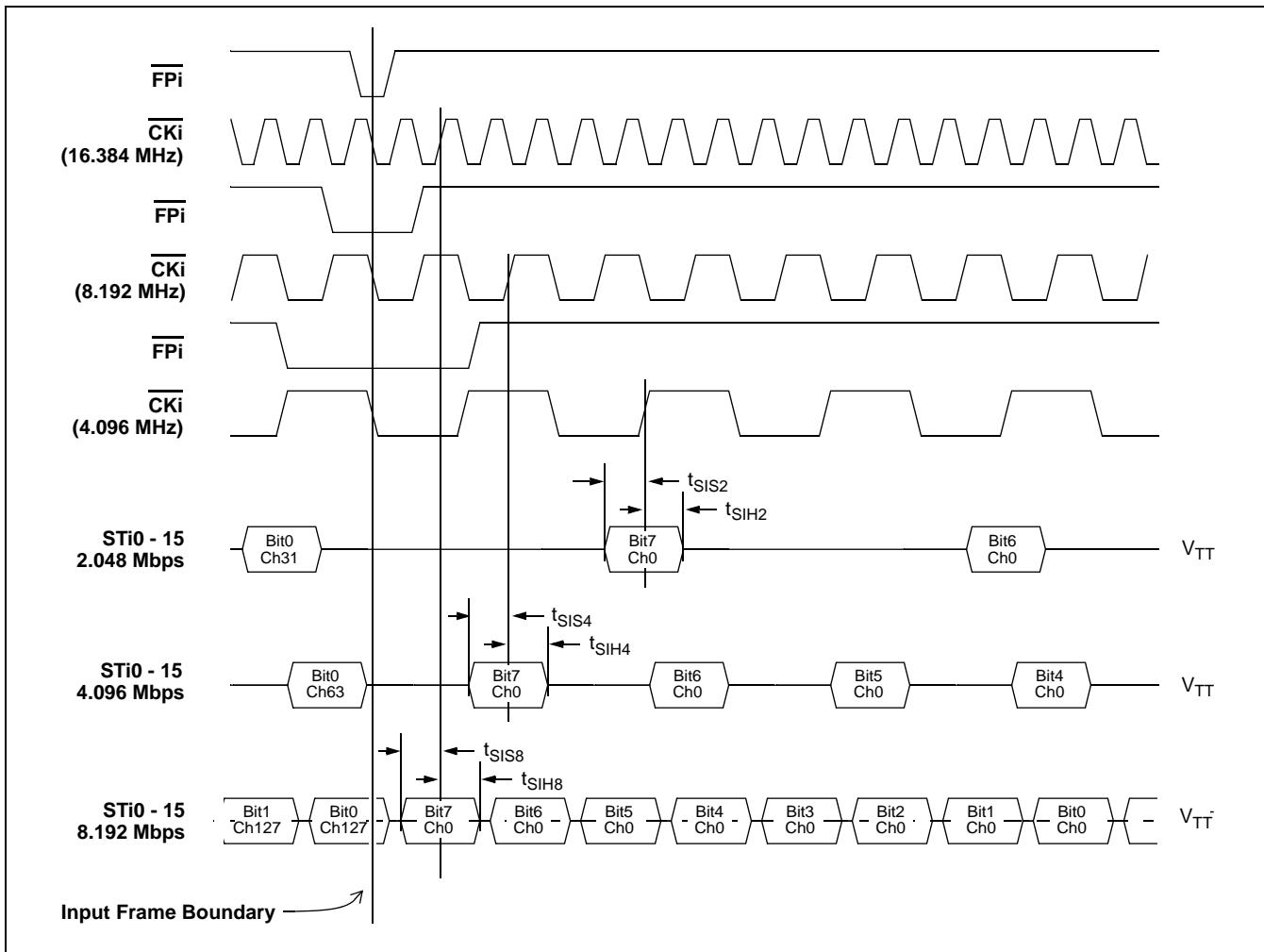

**Figure 44 - ST-BUS Inputs (STi0 - 15) Timing Diagram**

**AC Electrical Characteristics† - ST-BUS Output Timing**

	Characteristic	Sym.	Min.	Typ.‡	Max.	Units	Test Conditions
1	STo Delay - Active to Active @2.048 Mbps @4.096 Mbps @8.192 Mbps	$t_{SOD2}$ $t_{SOD4}$ $t_{SOD8}$			10 10 10	ns ns ns	$C_L = 30\text{ pF}$

† Characteristics are over recommended operating conditions unless otherwise stated.

‡ Typical figures are at 25°C,  $V_{DD}$  at 3.3 V and are for design aid only: not guaranteed and not subject to production testing.

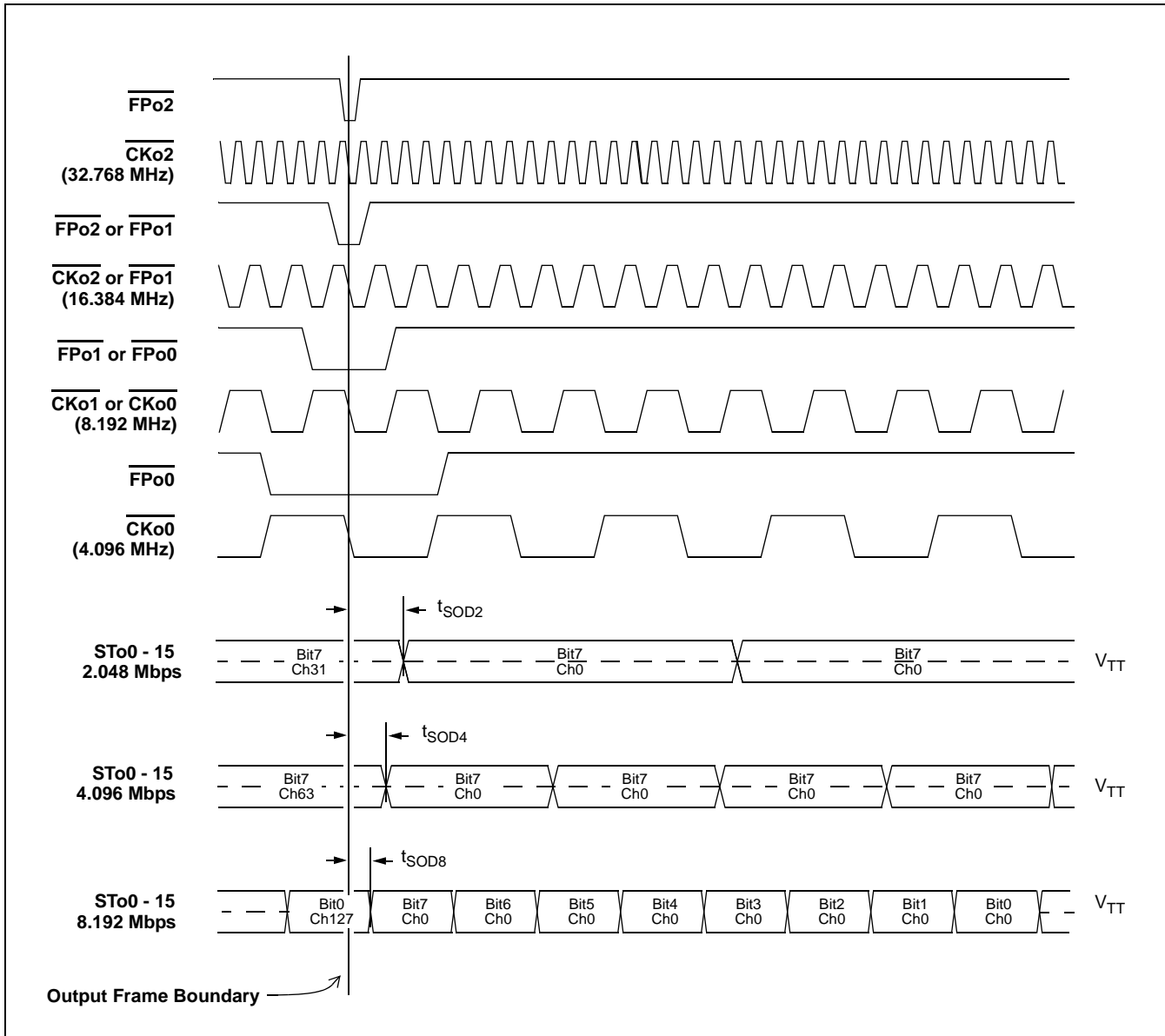

**Figure 45 - ST-BUS Outputs (STo0 - 15) Timing Diagram**



**AC Electrical Characteristics† - ST-BUS Output Tristate Timing**

	Characteristic	Sym.	Min.	Typ. ‡	Max.	Units	Test Conditions
1	STo Delay - Active to High-Z STo Delay - High-Z to Active 2.048 Mbps 4.096 Mbps 8.192 Mbps	$t_{DZ}, t_{ZD}$			15 15 15	ns ns ns	$R_L=1\text{ K},$ $C_L=30\text{ pF},$ See Note 1.
2	Output Driver Enable (ODE) Delay - High-Z to Active 2.048 Mbps 4.096 Mbps 8.192 Mbps	$t_{ZD\_ODE}$			45 45 45	ns ns ns	
2	Output Driver Disable (ODE) Delay - Active to High-Z 2.048 Mbps 4.096 Mbps 8.192 Mbps	$t_{DZ\_ODE}$			30 30 30	ns ns ns	

† Characteristics are over recommended operating conditions unless otherwise stated.

‡ Typical figures are at 25°C and are for design aid only; not guaranteed and not subject to production testing.

\* Note 1: High Impedance is measured by pulling to the appropriate rail with  $R_L$ , with timing corrected to cancel the time taken to discharge  $C_L$ .

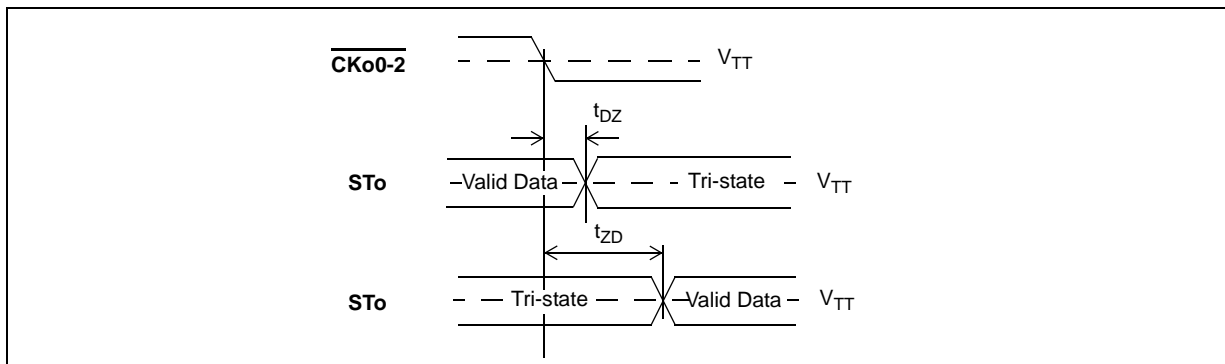

**Figure 46 - Serial Output and External Control**

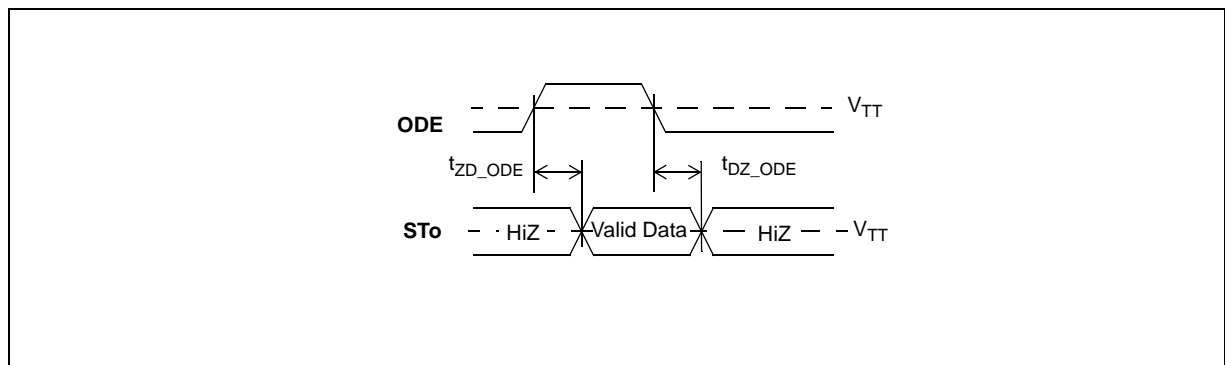
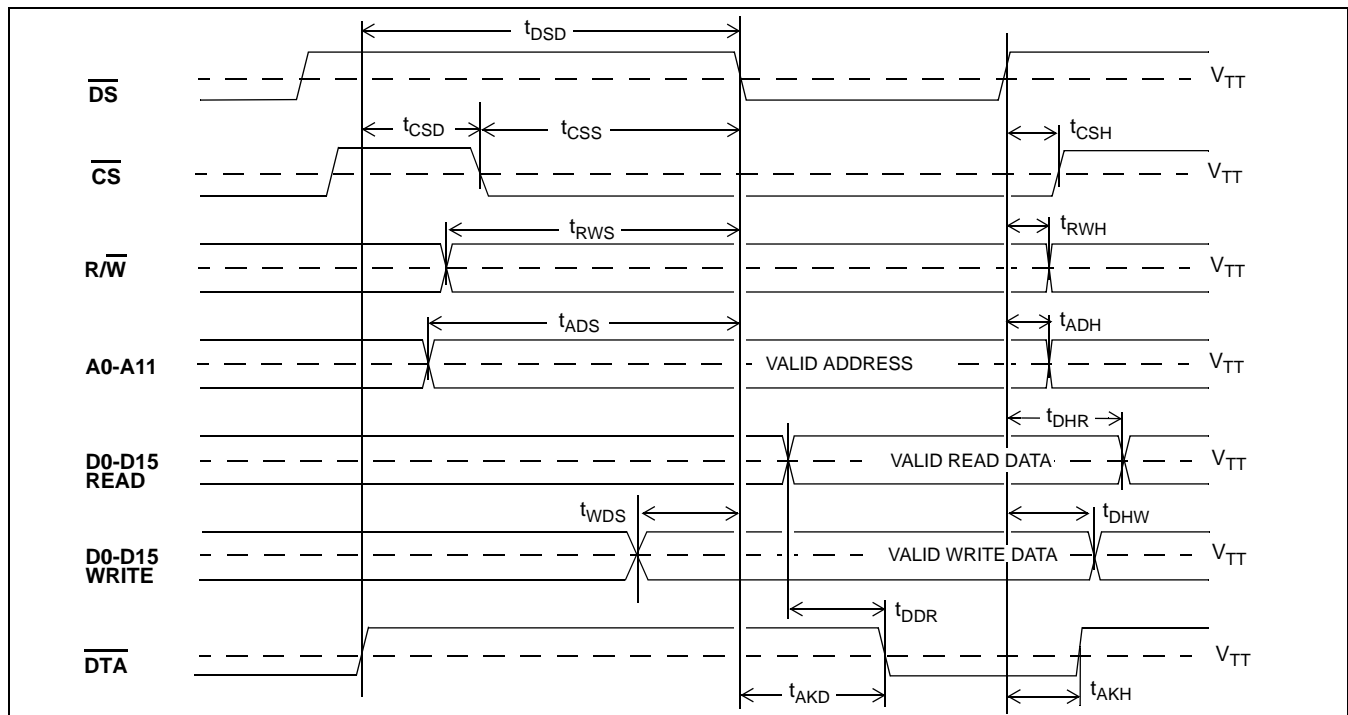

**Figure 47 - Output Driver Enable (ODE)**

**AC Electrical Characteristics - Motorola Non-Multiplexed Bus Mode**

	Characteristics	Sym.	Min.	Typ.	Max.	Units	Test Conditions <sup>2</sup>
1	$\overline{CS}$ setup from $\overline{DS}$ falling	$t_{CSS}$	0			ns	
2	R/W setup from $\overline{DS}$ falling	$t_{RWS}$	10			ns	
3	Address setup from $\overline{DS}$ falling	$t_{ADS}$	5			ns	
4	$\overline{DS}$ delay from the rising edge of $\overline{DTA}$ to the falling edge of the $\overline{DS}$	$t_{DSD}$	50			ns	
5	$\overline{CS}$ delay from the rising edge of $\overline{DTA}$ to the falling edge of the $\overline{CS}$	$t_{CSD}$	50			ns	
6	$\overline{CS}$ hold after $\overline{DS}$ rising	$t_{CSH}$	0			ns	
7	R/W hold after $\overline{DS}$ rising	$t_{RWH}$	0			ns	
8	Address hold after $\overline{DS}$ rising	$t_{ADH}$	0			ns	
9	Data setup from $\overline{DTA}$ Low on Read	$t_{DDR}$	20			ns	$C_L=30$ pF
10	Data hold on read	$t_{DHR}$	3		9	ns	$C_L=30$ pF, $R_L=1$ K (Note 1)
11	Data setup from $\overline{DS}$ falling on write	$t_{WDS}$	10			ns	
12	Data hold on write	$t_{DHW}$	0			ns	
13	Acknowledgment Delay: Reading/Writing Registers Reading/Writing Memory	$t_{AKD}$			120/105 200/150	ns ns	$C_L=30$ pF $C_L=30$ pF
14	Acknowledgment Hold Time	$t_{AKH}$			20	ns	$C_L=30$ pF, $R_L=1$ K (Note 1)

Note 1: High Impedance is measured by pulling to the appropriate rail with  $R_L$ , with timing corrected to cancel time taken to discharge  $C_L$ .  
 Note 2: A delay of 600 microseconds must be applied before the first microprocessor access is performed after the RESET pin is set high.

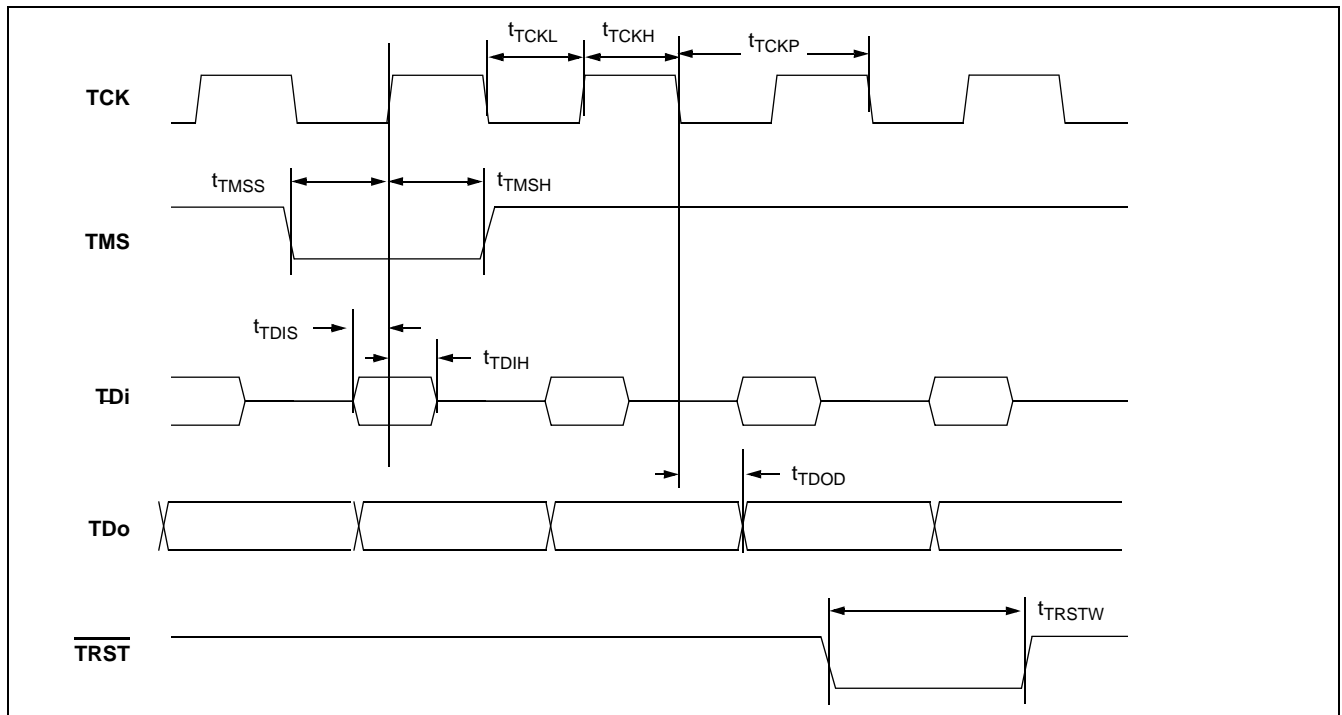

**Figure 48 - Motorola Non-Multiplexed Bus Timing**

**AC Electrical Characteristics† - JTAG Test Port and Reset Pin Timing**

	Characteristic	Sym.	Min.	Typ.	Max.	Units	Notes
1	TCK Clock Period	$t_{TCKP}$	100			ns	
2	TCK Clock Pulse Width High	$t_{TCKH}$	80			ns	
3	TCK Clock Pulse Width Low	$t_{TCKL}$	80			ns	
4	TMS Set-up Time	$t_{TMSS}$	10			ns	
5	TMS Hold Time	$t_{TMSh}$	10			ns	
6	TDi Input Set-up Time	$t_{TDis}$	20			ns	
7	TDi Input Hold Time	$t_{TDIH}$	60			ns	
8	TD0 Output Delay	$t_{TDOD}$		25		ns	$C_L=30$ pF
9	$\overline{TRST}$ pulse width	$t_{TRSTW}$	200			ns	
10	Reset pulse width	$t_{RSTW}$	1.0			ms	

†Characteristics are over recommended operating conditions unless otherwise stated.



**Figure 49 - JTAG Test Port Timing Diagram**

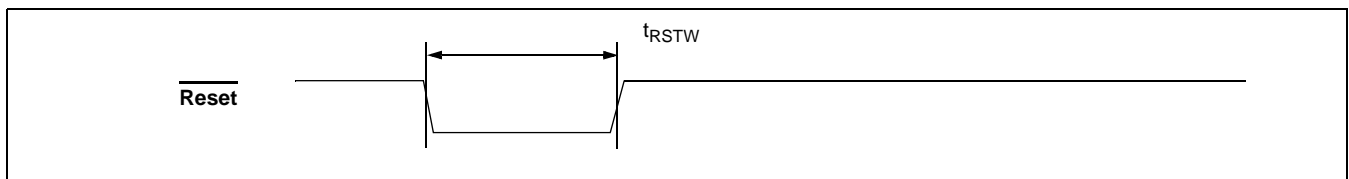

**Figure 50 - Reset Pin Timing Diagram**

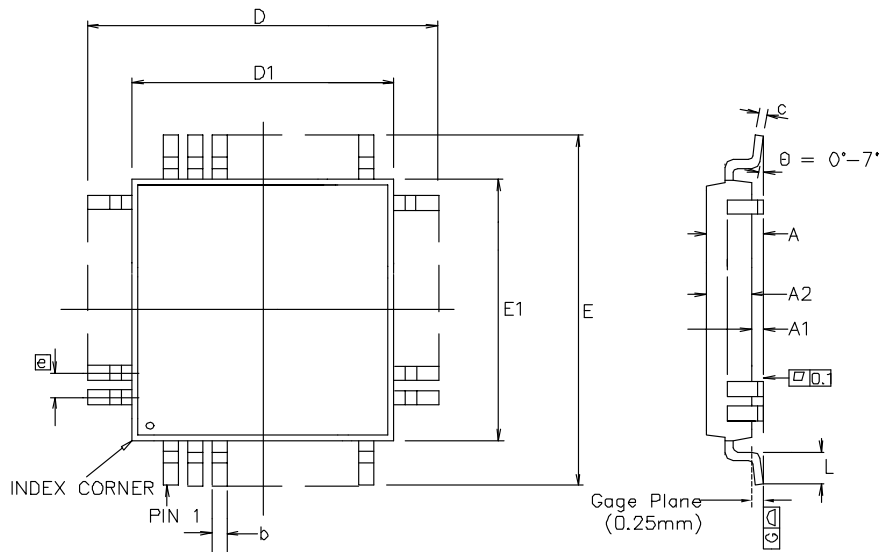

Symbol	Control Dimensions in millimetres		Altern. Dimensions in inches	
	MIN	MAX	MIN	MAX
A	---	1.60	---	0.047
A1	0.05	0.15	0.002	0.006
A2	1.35	1.45	0.053	0.057
D	26.00 BSC		1.024 BSC	
D1	24.00 BSC		0.945 BSC	
E	26.00 BSC		1.024 BSC	
E1	24.00 BSC		0.945 BSC	
L	0.45	0.75	0.018	0.030
e	0.50 BSC		0.020 BSC	
b	0.17	0.27	0.007	0.011
c	0.09	0.20	0.004	0.008
Pin features				
N	160			
ND	40			
NE	40			
NOTE	SQUARE			

Conforms to JEDEC MS-026 BGA Iss. C  
Except for number of pins.

Notes:

1. Pin 1 indicator may be a corner chamfer, dot or both.
2. Controlling dimensions are in millimeters.
3. The top package body size may be smaller than the bottom package body size by a max. of 0.15 mm.
4. Dimension D1 and E1 do not include mould protrusion.
5. Dimension b does not include dambar protrusion.
6. Coplanarity, measured at seating plane G, to be 0.08 mm max.

© Zarlink Semiconductor 2002 All rights reserved.				 <b>ZARLINK</b> SEMICONDUCTOR	Package Code	
ISSUE	1	2	3		Previous package codes	Package Outline for 160 Lead LQFP (QC) (24x24x1.4)mm + 2.0mm (footprint)
ACN	201652	207156	213835			
DATE	12Dec96	16Jul99	11Dec02			
APPRD.						GPD00269

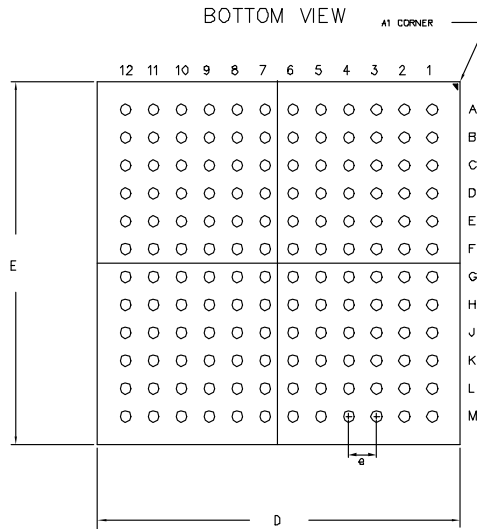
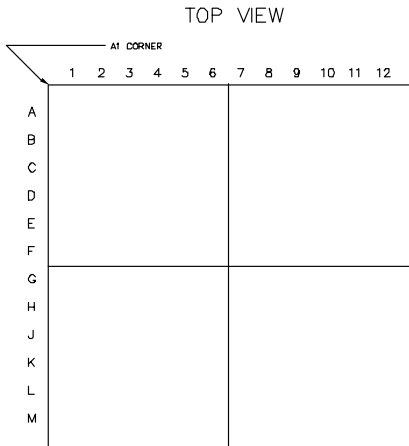

DIMENSION	MIN	MAX
A	—	1.25
A1	0.25	0.35
A2	0.53	REF
D	12.95	13.05
E	12.95	13.05
b	0.35	0.45
e	1.00	
N	144	
Conforms to JEDEC MO-192		

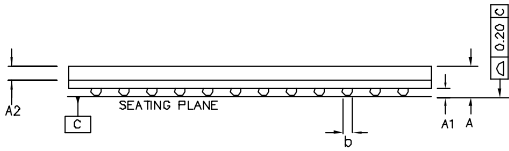

NOTES: -

1. Controlling dimensions are in MM.
2. Seating plane is defined by the spherical crown of the solder balls.
3. Not to scale.
4. N is the number of solder balls
5. Substrate thickness is 0.36 MM.

© Zarlink Semiconductor 2002 All rights reserved.

ISSUE	1	2		
ACN	213740	213834		
DATE	15Nov02	11Dec02		
APPRD.				



Package Code GD

Previous package codes

Package Outline for  
144Ball LPGA  
13x13x1.25mm

GPD00805



**For more information about all Zarlink products  
visit our Web Site at  
[www.zarlink.com](http://www.zarlink.com)**

Information relating to products and services furnished herein by Zarlink Semiconductor Inc. or its subsidiaries (collectively "Zarlink") is believed to be reliable. However, Zarlink assumes no liability for errors that may appear in this publication, or for liability otherwise arising from the application or use of any such information, product or service or for any infringement of patents or other intellectual property rights owned by third parties which may result from such application or use. Neither the supply of such information or purchase of product or service conveys any license, either express or implied, under patents or other intellectual property rights owned by Zarlink or licensed from third parties by Zarlink, whatsoever. Purchasers of products are also hereby notified that the use of product in certain ways or in combination with Zarlink, or non-Zarlink furnished goods or services may infringe patents or other intellectual property rights owned by Zarlink.

This publication is issued to provide information only and (unless agreed by Zarlink in writing) may not be used, applied or reproduced for any purpose nor form part of any order or contract nor to be regarded as a representation relating to the products or services concerned. The products, their specifications, services and other information appearing in this publication are subject to change by Zarlink without notice. No warranty or guarantee express or implied is made regarding the capability, performance or suitability of any product or service. Information concerning possible methods of use is provided as a guide only and does not constitute any guarantee that such methods of use will be satisfactory in a specific piece of equipment. It is the user's responsibility to fully determine the performance and suitability of any equipment using such information and to ensure that any publication or data used is up to date and has not been superseded. Manufacturing does not necessarily include testing of all functions or parameters. These products are not suitable for use in any medical products whose failure to perform may result in significant injury or death to the user. All products and materials are sold and services provided subject to Zarlink's conditions of sale which are available on request.

Purchase of Zarlink's I<sup>2</sup>C components conveys a licence under the Philips I<sup>2</sup>C Patent rights to use these components in and I<sup>2</sup>C System, provided that the system conforms to the I<sup>2</sup>C Standard Specification as defined by Philips.

Zarlink, ZL and the Zarlink Semiconductor logo are trademarks of Zarlink Semiconductor Inc.

Copyright Zarlink Semiconductor Inc. All Rights Reserved.

**TECHNICAL DOCUMENTATION - NOT FOR RESALE**