

**SANYO**

No. 4842

**LA3460M****FM NC + MPX Demodulator  
for Car Stereo Tuners****Overview**

The LA3460M is a high performance car stereo tuner IC that includes an FM noise canceller and a stereo multiplex demodulator.

**Functions****[Noise Canceller Block]**

- Built-in low- and high-pass filters
- Noise AGC
- Pilot signal compensation function

**[Multiplex Block]**

- Adjustment-free VCO (456 kHz)
- Level follower type pilot canceller
- SNC (stereo noise control)
- HCC (high cut control)
- Stereo indicator driver
- VCO oscillator stop function

**Features****[Noise Canceller Block]**

- Improved ignition noise rejection during medium to weak field reception  
Adoption of a new noise AGC circuit  
Optimized gate time
- High audio quality design with malfunction prevention in the high frequency band and for overmodulated signals  
Improved dynamic range low-pass and high-pass filters

**[Multiplex Block]**

- High signal-to-noise ratio and low distortion (stereo S/N ratio: 79 dB, THD: 0.1 %)
- Good high frequency band separation (50 dB at 1 kHz and 30 dB at 10 kHz)
- Adoption of a PLL circuit with an adjustment-free VCO (456 kHz ceramic resonator)
- Improved pilot cancellation level (25 to 30 dB) using a new cancellation circuit
- Built-in 114 kHz and 190 kHz anti-birdie filters
- Adoption of new SNC characteristics to reduce multipath noise
- Reduced printed circuit board space requirements due to the adoption of a mini-flat package (MFP-24)

**Package Dimensions**

unit: mm

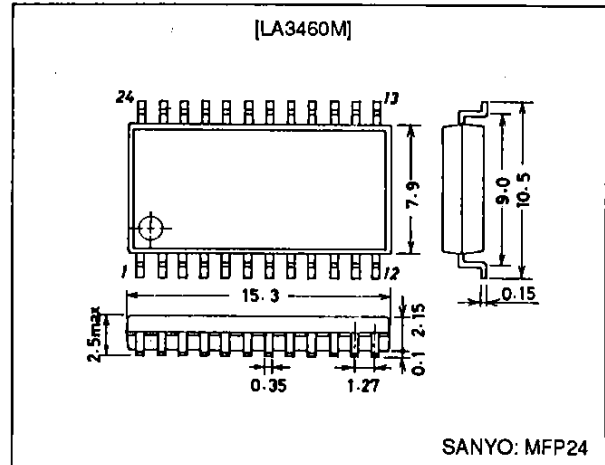
**3045B-MFP24****SANYO Electric Co., Ltd. Semiconductor Business Headquarters**

TOKYO OFFICE Tokyo Bldg., 1-10, 1 Chome, Ueno, Taito-ku, TOKYO, 110 JAPAN

## Specifications

Maximum Ratings at  $T_a = 25^\circ\text{C}$

Parameter	Symbol	Conditions	Ratings	Unit
Maximum supply voltage	$V_{CC\text{ max}}$		10	V
Lamp influx current	$I_L\text{ max}$		30	mA
Allowable power dissipation	$P_d\text{ max}$	$T_a = 85^\circ\text{C}$	490	mW
Operating temperature	$T_{opr}$		-40 to +85	$^\circ\text{C}$
Storage temperature	$T_{stg}$		-40 to +150	$^\circ\text{C}$

Operating Conditions at  $T_a = 25^\circ\text{C}$

Parameter	Symbol	Conditions	Ratings	Unit
Recommended supply voltage	$V_{CC}$		8.0	V
Operating supply voltage range	$V_{CC\text{ op}}$		7.0 to 9.0	V

## Operating Characteristics

at  $T_a = 25^\circ\text{C}$ ,  $V_{CC} = 8.0\text{ V}$ ,  $V_i = 300\text{ mVrms}$ ,  $f = 1\text{ kHz}$ ,  $L + R = 90\%$ , pilot = 10% modulation,  $V_{SNC} (V_8) = 3\text{ V}$ ,  $V_{HCC} (V_9) = 3\text{ V}$

Parameter	Symbol	Conditions	min	typ	max	Unit
Quiescent current	$I_{cco}$	No input	15	25	35	mA
Channel separation	SEP		30	50		dB
Total harmonic distortion	THD	MONO		0.06	0.5	%
Lamp lit level	$V_L$	Pilot signal	4.0	7.3	13.0	mVrms
Lamp hysteresis	hy			3.0	6.0	dB
Demodulator output	$V_O$	MONO	260	330	410	mVrms
S/N ratio	S/N	$R_g = 0\ \Omega$ , MONO		70	85	dB
Channel balance	CB	MONO $20 \times \log(L/R)$	-1.0	0	+1.0	dB
Pilot cancellation	PC	30 mVrms pilot signal	10	26		dB
Gate time	tgate	1 $\mu\text{s}$ 100 mVp-o, pulse input, $f = 1\text{ kHz}$		30	60	$\mu\text{s}$
Noise sensitivity	$S_N$	1 $\mu\text{s}$ pulse input, $f = 1\text{ kHz}$		30	60	mVp-o
SNC	SNC (1)	$V = 1.2\text{ V}$ , separation L $\rightarrow$ R	30	50		dB
	SNC (2)	$V = 0.6\text{ V}$ , separation L $\rightarrow$ R	6.0	8.5	11.0	dB
	SNC (3)	$V = 0.1\text{ V}$ , separation L $\rightarrow$ R		0.5	2.0	dB
HCC	HCC (1)	$V = 1.2\text{ V}$ , $f = 10\text{ kHz}$ , left output	-1.0	0	+1.0	dB
	HCC (2)	$V = 0.6\text{ V}$ , $f = 10\text{ kHz}$ , left output	-8.0	-5.0	-2.0	dB
	HCC (3)	$V = 0.1\text{ V}$ , $f = 10\text{ kHz}$ , left output	-14.0	-10.0	-6.0	dB

# LA3460M

## Pin Functions

Pin No.	Function	Description
1	Noise sensitivity	Noises sensitivity adjustment
2	Noise AGC	
3	Gate time	
4	Hold circuit	
5	Pilot output	
6	V <sub>CC</sub>	V <sub>CC</sub> = +8.0 V
7	HCC capacitor	High cut filter
8	SNC control	
9	HCC control	
10	Left channel output	
11	Right channel output	
12	Pilot canceller input	
13	Pilot canceller output	
14	Separation adjustment	
15	NC	
16	NC	
17	456 kHz oscillator circuit	Ceramic resonator
18	Phase comparator L.P.F (+)	Phase comparator low-pass filter
19	Phase comparator L.P.F (-)	Phase comparator low-pass filter
20	GND	
21	PLL input	PLL input
22	Stereo indicator	Active low
23	Composite input	Composite signal input
24	Pilot detector lpf	

## Pin Assignment

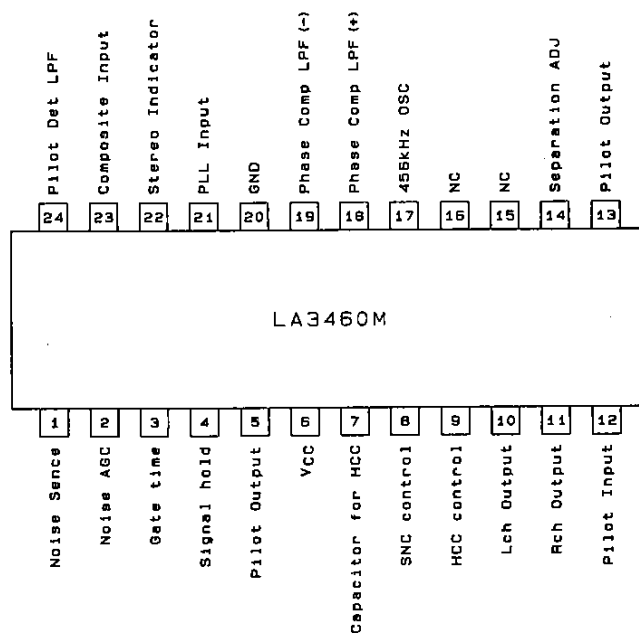

Top view

A02836

# LA3460M

## Equivalent Circuit Block Diagram

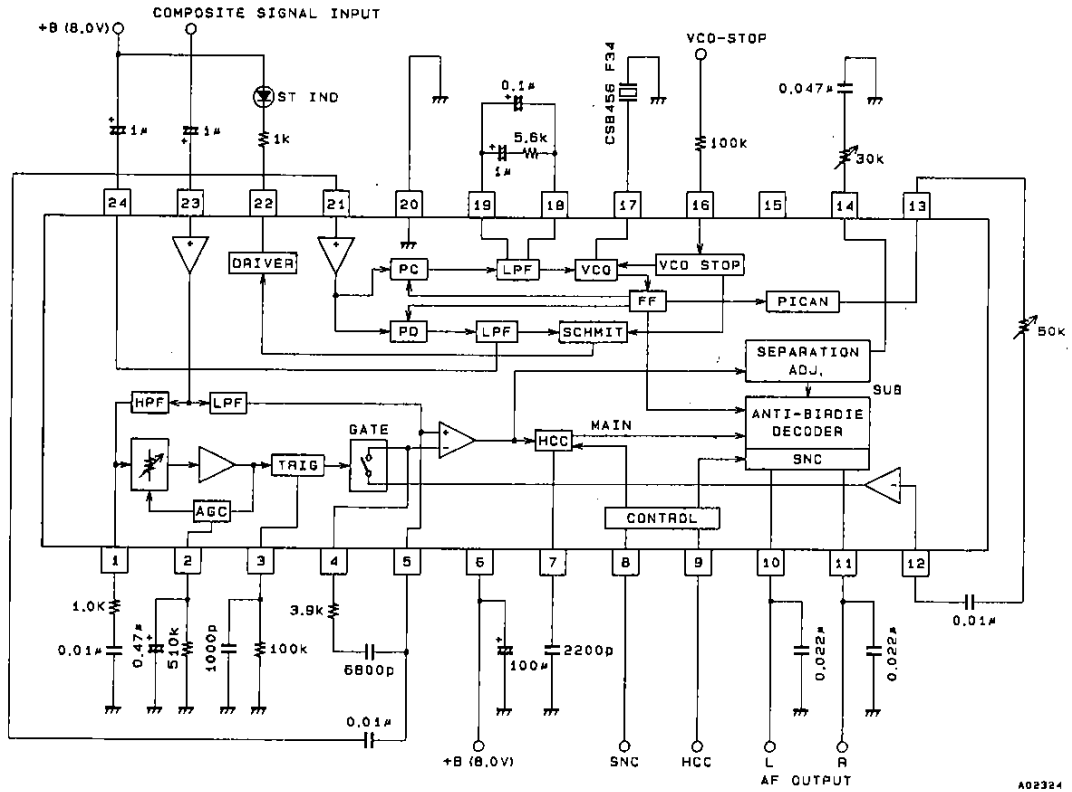

A02324

Unit (resistance:  $\Omega$ , capacitance: F)

## Sample Application Circuit

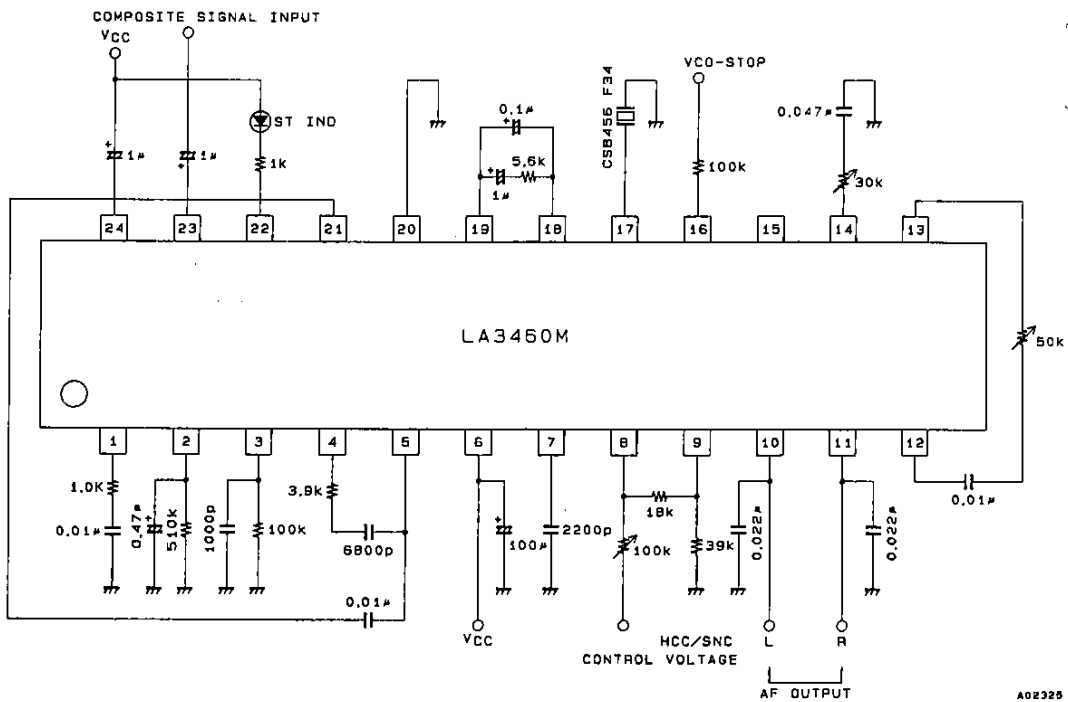

A02325

Unit (resistance:  $\Omega$ , capacitance: F)

Pin Functions

[NC]

Unit (resistance:  $\Omega$ , capacitance: F)

Pin	Function	Internal equivalent circuit	Remarks
23	Noise canceller input	<p>A02342</p>	The input impedance is about 50 k $\Omega$ .
1 2	Noise canceller AGC sensitivity adjustments	<p>A02326</p>	After setting up medium field (about 50 dB $\mu$ ) reception with the noise sensitivity setting pin (pin 1), set up weak field (20 to 30 dB $\mu$ ) reception with the AGC adjustment pin (pin 2).
3	Monostable multivibrator time constant	<p>A02327</p>	Set this time constant so that the gate time is about 30 $\mu$ s. Increasing the gate time improves the noise exclusion efficiency. However, care is required since the apparent distortion due to multipath or overmodulation will increase.

Continued on next page.

LA3460M

Continued from preceding page.

Pin	Function	Internal equivalent circuit	Remarks
4 5	Memory circuit connection		Memory circuit used during noise canceller operation
12	Pilot canceller signal input		The pilot signal level requires adjustment due to variations in the IF output level and other parameters.

LA3460M

[MPX]

Pin	Function	Internal equivalent circuit	Remarks
21	Pilot input		Pin 21 is the PLL circuit input.
7	HCC capacitor		The HCC frequency characteristics are determined by the value of the external capacitor connected to this pin.
20	N.C MPX GND		Noise canceller and MPX circuit ground
10 11	MPX output (left) MPX output (right)		

Continued on next page.

LA3460M

Continued from preceding page.

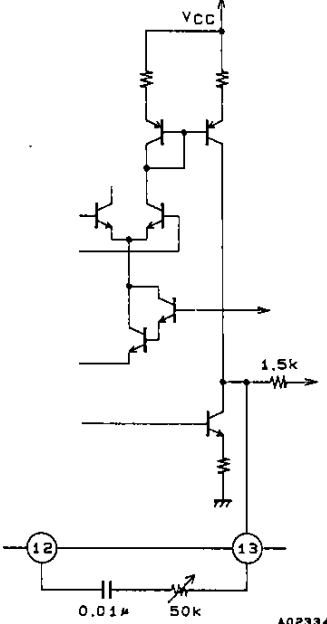
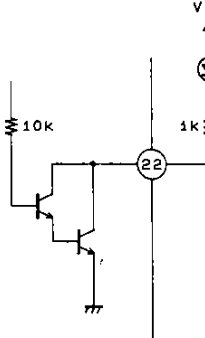
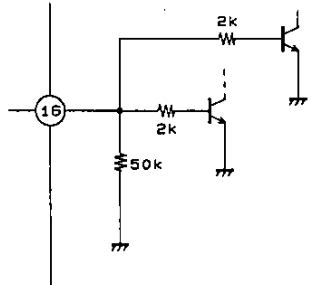
Pin	Function	Internal equivalent circuit	Remarks
13	Pilot canceller signal input	 <p style="text-align: right;">A02334</p>	Pin 13 is the pilot canceller signal input.
22	Stereo indicator	 <p style="text-align: right;">A02341</p>	Stereo indicator This is an active-low signal.
16	OSC-stop	 <p style="text-align: right;">A02336</p>	

Continued on next page.



LA3460M

Continued from preceding page.

Pin	Function	Internal equivalent circuit	Remarks
14	Separation adjustment	<p style="text-align: right;">A02335</p>	<p>The trimmer connected at this pin is used to adjust the sub-decoder input level. (The output level in mono (main) mode is not affected.)</p>
17	VCO	<p style="text-align: right;">A02337</p>	<p>The oscillator frequency is 456 kHz.</p>
18 19	Phase comparator	<p style="text-align: right;">A02338</p>	

Continued on next page.

Continued from preceding page.

Pin	Function	Internal equivalent circuit	Remarks
9	HCC control input		
8	SNC control input		<p>The sub-output is controlled by an input between 0 and 1 V.</p>
24	Pilot detector		<p>The circuit is forced to mono by the insertion of a 1 MΩ resistor between pin 24 and V<sub>CC</sub>.</p>

## Usage Notes

## 1. Noise Canceller Block

- The noise canceller input (pin 23) has an input impedance of about 50 kΩ. Carefully consider low-area frequency characteristics when determining the value of the coupling capacitor. In an application circuit that uses a 1 μF capacitor,  $f_c$  will be about 3 Hz.
- Pins 1 and 2 are used to set the noise detector sensitivity and the noise AGC level. Setting up these values is easier if the noise sensitivity is set with pin 1 for a medium field strength (an antenna input of about 50 dBμ) first, and then the AGC is adjusted with pin 2 for a weak field strength (20 to 30 dBμ). A point that requires caution is that although the AGC action is improved if the noise detector sensitivity is increased, the weak field sensitivity will, inversely, be lowered.
- The time constant of the monostable multivibrator (pin 3) will be about 30 μs when C is 0.001 μF and R is 100 kΩ. The noise exclusion efficiency increases if the gate time is increased. However, distortion due to multipath and overmodulation is increased.

## 2. MPX Block

- HCC (high cut control) frequency characteristics (pin 7)

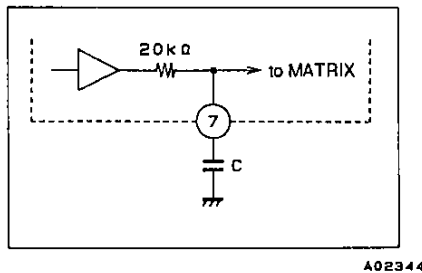

$$f_c = \frac{1}{2\pi \times C \times 20k\Omega} \text{ [ Hz ]}$$

The value of the external capacitor connected to pin 7 determines the output signal frequency characteristics during HCC control.

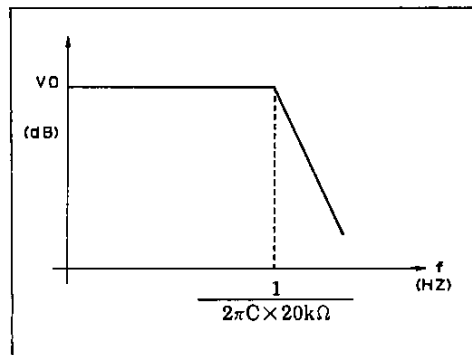

- Pilot canceller adjustment (pins 12 and 13)

The pin 13 pilot canceller signal waveform is a 19 kHz signal that does not include the third harmonic component, as shown in the figure below. There is no need for a capacitor between pin 13 and ground, since this signal has the same phase as the pilot signal. Since it does not include a third harmonic component, good pilot cancellation in the left and right channel outputs can be obtained by adjusting the variable resistor.

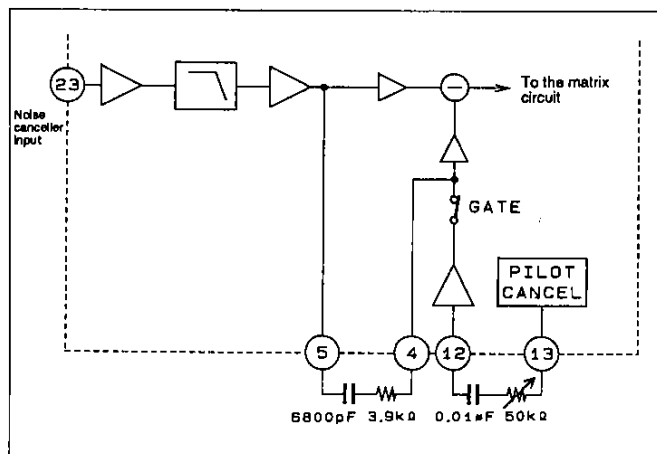

A02346

- Separation adjustment (pin 14)

The separation is adjusted by varying the sub-decoder input level with the variable resistor connected to pin 14. When the variable resistor is changed, only the sub-demodulation level is changed, and the mono (main) output level is not changed. The decoder high band separation will not be degraded in the sub-signal frequency band (23 to 53 kHz) if the value of the external capacitor C is made sufficiently small relative to the impedance of the variable resistor.

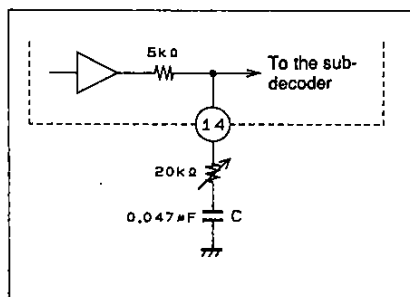

A02347

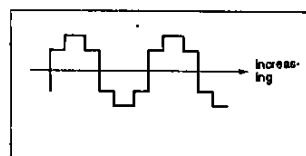

A02348

- No products described or contained herein are intended for use in surgical implants, life-support systems, aerospace equipment, nuclear power control systems, vehicles, disaster/crime-prevention equipment and the like, the failure of which may directly or indirectly cause injury, death or property loss.
- Anyone purchasing any products described or contained herein for an above-mentioned use shall:
  - ① Accept full responsibility and indemnify and defend SANYO ELECTRIC CO., LTD., its affiliates, subsidiaries and distributors and all their officers and employees, jointly and severally, against any and all claims and litigation and all damages, cost and expenses associated with such use;
  - ② Not impose any responsibility for any fault or negligence which may be cited in any such claim or litigation on SANYO ELECTRIC CO., LTD., its affiliates, subsidiaries and distributors or any of their officers and employees jointly or severally.
- Information (including circuit diagrams and circuit parameters) herein is for example only; it is not guaranteed for volume production. SANYO believes information herein is accurate and reliable, but no guarantees are made or implied regarding its use or any infringements of intellectual property rights or other rights of third parties.