

DUAL COMPARATOR

- Be Possible to Operate at the Wide Range Single or Two Supply Voltage.
- Low Supply Current : $I_{CC}=0.8mA(Typ.)$.
- Low Input Offset Voltage : $V_{IO}=2mV(Typ.)$.
- Wide Common Mode Input Voltage : $0V_{DC}$ to $V_{CC}-1.5V_{DC}$.
- Output is Compatible with TTL, DTL, MOS and C-MOS.
- Output is Open Collector and Wired-OR Possible.
- Possible to exchange the position of Pin⑨ for Pin① because of Pin connection being symmetric (KIA393S only).
- The Pin① and Pin⑨ of Lead frame was each other connected (KIA393S Only).

PIN CONNECTION (TOP VIEW)

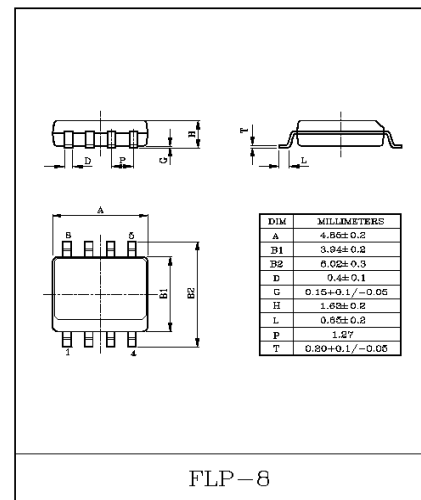
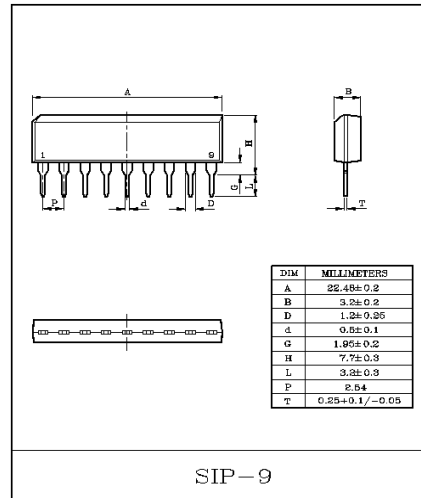
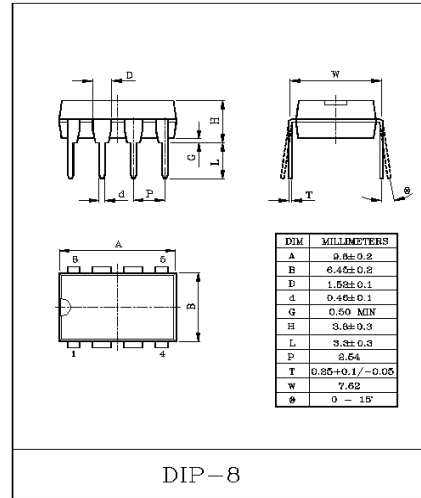
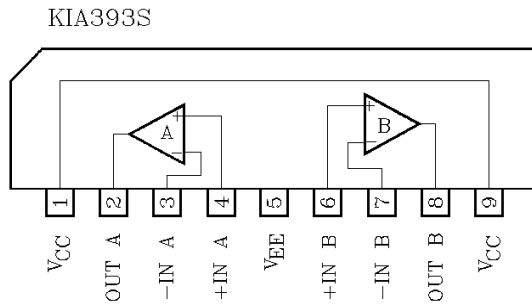
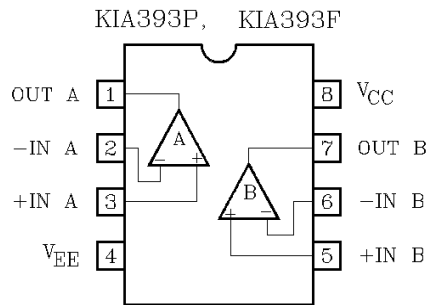

KIA393P/S/F

MAXIMUM RATINGS (Ta=25°C)

CHARACTERISTIC		SYMBOL	RATING	UNIT
Supply Voltage		V _{CC}	±18, 36	V
Differential Input Voltage		DV _{IN}	±18, 36	V
Common Mode Input Voltage		CMV _{IN}	-0.3~V _{CC}	V
Power Dissipation	KIA393P	P _D	500	mW
	KIA393S			
	KIA393F		240	
Operating Temperature		T _{opr}	-40~85	°C
Storage Temperature		T _{stg}	-55~125	°C
Pin① to Pin⑨ Maximum Current	KIA393S	I _{MAX}	1	A

ELECTRICAL CHARACTERISTICS (V_{CC}=5V, V_{EE}=GND, Ta=25°C)

CHARACTERISTIC	SYMBOL	TEST CONDITION	MIN.	TYP.	MAX.	UNIT
Input Offset Voltage	V _{IO}	V _O =1.4V	-	2	5	mV
Input Offset Current	I _{IO}	-	-	5	50	nA
Input Bias Current	I _I	-	-	25	250	nA
Common Mode Input Voltage	CMV _{IN}	-	0	V _{CC} -1.5	-	V
Voltage Gain	G _V	R _L =15kΩ	-	200	-	V/mV
Supply Current	I _{CC}	No load	-	0.8	2	mA
Sink Current	I _{sink}	+IN=0V, -IN=1V, V _{OL} =1.5V	6	16	-	mA
Output Voltage ("L" Level)	V _{OL}	+IN=0V, -IN=1V, I _{sink} =3mA	-	0.2	0.4	V
Output Leak Current	I _{LEAK}	+IN=1V, -IN=0V, V _O =5V	-	0.1	-	nA
Response Time	t _{rsp}	R _L =5.1kΩ, C _L =15pF	-	1.3	-	μS

EQUIVALENT CIRCUIT

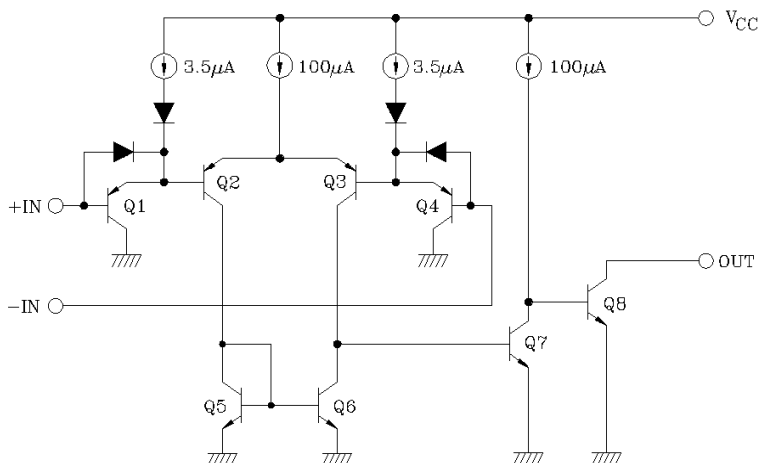

KIA393P/S/F

