

SANYO	No. ※4564	LC58E7008
		On-Chip EPROM Microcomputer 4-Bit Single Chip Microcontroller with LCD Driver, 16 Kbytes of EPROM and 2 Kbits of RAM On-Chip

Preliminary

Overview

The LC58E7008 is an on-chip EPROM microcontroller in the LC58700X series of CMOS 4-bit single chip microcontrollers.

The LC58E7008 provides the same functionality as the LC587008 mask ROM version, and has the same pin layout. The LC58E7008 has a 16-Kbyte EPROM capacity, and corresponds to the LC587004, LC587006 and LC587008.

The LC58E7008 is provided in an 80-pin ceramic window package, and programs can be written and erased repeatedly. Thus it is optimal for use during program development.

Applications

The LC58E7008 can be used for program and function evaluation in the following applications.

- System control of consumer products that use LCD displays, such as cameras, CD players and tuners
- Remote controllers for products such as VCRs or tuners
- System control of instruments that use LCD displays, such as miniature test equipment and medical equipment.
- The LC58E7008 is optimal for products that use LCD displays, in particular, battery operated products.

Features

- Optional functions can be switched by EPROM data settings.

The LC58E7008 includes both program and option selection EPROM on-chip. The option selection EPROM can be used to specify almost all of the LC58700X options, including crystal/ceramic oscillator specifications, port hold transistor selection and segment PLA specifications. These option specifications allow functional and operational testing in the actual PC board used in the mass-produced end product.

- On-chip 16 Kbyte program EPROM

The on-chip 16 Kbyte program EPROM allows the LC58E7008 to be used to evaluate all three members of the LC58700X series. (See the series structure table on the next page.)

- Program and option data read/write

The program and option data can be read and written with a standard commercial EPROM writer by using a dedicated EPROM writing board. (256K equivalent)

(Use either a programmer made by Advantest Corporation or an equivalent product as the EPROM programmer.)

- Pin correspondence

The LC58E7008 is pin compatible with the mask ROM versions. (There is no chip correspondence.)

Package Dimensions

unit: mm

3152A-QFC80

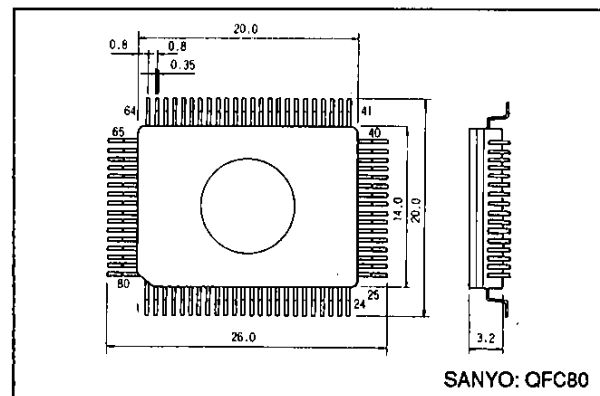

SANYO Electric Co., Ltd. Semiconductor Business Headquarters

TOKYO OFFICE Tokyo Bldg., 1-10, 1 Chome, Ueno, Taito-ku, TOKYO, 110 JAPAN

LC58E7008

Series Structure

Item \ Type No.	LC587004	LC587006	LC587008	LC58E7008
ROM capacity	4 K x 16 bits	6 K x 16 bits	8 K x 16 bits	EPROM: 16 Kbytes
RAM capacity	512 x 4 bits	512 x 4 bits	512 x 4 bits	512 x 4 bits
Package	QIP80	QIP80	QIP80	QFC80 ceramic window package
Notes	Available in quantity	Available in quantity	Available in quantity	The on-chip EPROM window version will be available shortly.

Usage Notes

The LC58E7008 is designed for use in developing and evaluating programs for the microcontrollers in the LC58700X series. However, there are differences between the LC58E7008 and the mask ROM versions. Keep the following points in mind when using the LC58E7008.

1. Notes on Reset

When the RES pin input changes from high to low, the reset state is cleared after the prescribed oscillator stabilization period has elapsed. The options and the segment PLA are set up during the first 256 cycles following the clearing of the reset state. Instructions are executed starting at location 0 after this setup phase has completed. (The options are undefined and the segment outputs are held at the V_{SS} level when the RES pin is high and during the first 256 cycles following the clearing of the reset state.)

2. Cover the LC58E7008's window with an opaque seal when writing data to EPROM.

3. The LC58E7008 and the mask ROM versions differ in the following points.

Item	LC58E7008	Mask ROM versions (LC58700X)	Note
Operating temperature	10 to 40°C	-30 to 70°C	
Operating supply voltage	2.8 to 5.5 V	2.0 to 6.0 V	
Operating supply currents	5 μ A typ. (3 V, 32 kHz crystal) 20 μ A typ. (5 V, 32 kHz crystal) 400 μ A typ. (5 V, 400 kHz ceramic) 500 μ A typ. (5 V, 2 MHz ceramic) 700 μ A typ. (5 V, 4 MHz ceramic)	4 μ A typ. (3 V, 32 kHz crystal) 15 μ A typ. (5 V, 32 kHz crystal) 400 μ A typ. (5 V, 400 kHz ceramic) 500 μ A typ. (5 V, 2 MHz ceramic) 700 μ A typ. (5 V, 4 MHz ceramic)	Hold mode
Common segment output states at reset	Segment pins: VSS level (CMOS output) Common pins: N-channel open drain	Static operation (LCD drive output)	<ul style="list-style-type: none"> Option switching in the EPROM version is performed by writing data to the option EPROM. Option switching in mask ROM versions is performed by specifying mask options.
Segment output states after the reset state is cleared	Off state	Off state/lit state	
Oscillator circuit specifications	CF/Xtal/CF + Xtal	CF/Xtal/CF + Xtal RC/RC+Xtal/EXT/EXT+Xtal	
Crystal oscillator circuit	32k/38k/65k (Note that this is 65k in the reset state)	32k/38k/65k	
RES pin specifications	Open (reset on high)	Open (reset on high) Open (reset on low) Pull-up (reset on low) Pull-down (reset on high)	
N ports	Open drain output	Open drain output/CMOS output	
LCD drive specifications	Static 1/2 bias, 1/2 duty 1/2 bias, 1/3 duty 1/2 bias, 1/4 duty 1/3 bias, 1/3 duty 1/3 bias, 1/4 duty (Substitute static when the LCD driver is not used.)	Static 1/2 bias, 1/2 duty 1/2 bias, 1/3 duty 1/2 bias, 1/4 duty 1/3 bias, 1/3 duty 1/3 bias, 1/4 duty (Substitute static when the LCD driver is not used.)	
Number of specifiable strobos	00 - 1E However, 0E and 0F cannot be used with the 4 MHz specifications.	00 - 1E However, 0E and 0F cannot be used with the 4 MHz specifications.	

Note: Although the strobos number 00 to 1E can be used with CF 2 MHz and lower specifications, strobos number 0E, 0F and 1E cannot be used with the CF 4 MHz specifications.

Pin Assignments

Pin No.	Symbol	Pin No.	Symbol	Pin No.	Symbol	Pin No.	Symbol
1	COM2	21	V _{DD2}	41	N3	61	Seg18
2	COM1	22	V _{DD1}	42	N4	62	Seg19
3	CUP1	23	V _{SS}	43	TST	63	Seg20
4	CUP2	24	V _{DD}	44	Seg1	64	Seg21
5	RES	25	CFIN	45	Seg2	65	Seg22
6	INT	26	CFOUT	46	Seg3	66	Seg23
7	SO1	27	S1	47	Seg4	67	Seg24
8	SO2	28	S2	48	Seg5	68	Seg25
9	SO3	29	S3	49	Seg6	69	Seg26
10	SO4	30	S4	50	Seg7	70	Seg27
11	A1	31	K1	51	Seg8	71	Seg28
12	A2	32	K2	52	Seg9	72	Seg29
13	A3	33	K3	53	Seg10	73	Seg30
14	A4	34	K4	54	Seg11	74	Seg31
15	P1	35	M1	55	Seg12	75	Seg32
16	P2	36	M2	56	Seg13	76	Seg33
17	P3	37	M3	57	Seg14	77	Seg34
18	P4	38	M4	58	Seg15	78	Seg35
19	XTOUT	39	N1	59	Seg16	79	COM4
20	XTIN	40	N2	60	Seg17	80	COM3

Note: 1. The TST pin must be connected to V_{SS} in normal operation.
 2. When mounting the LC58E7008, do not use solder dip techniques.

System Block Diagram

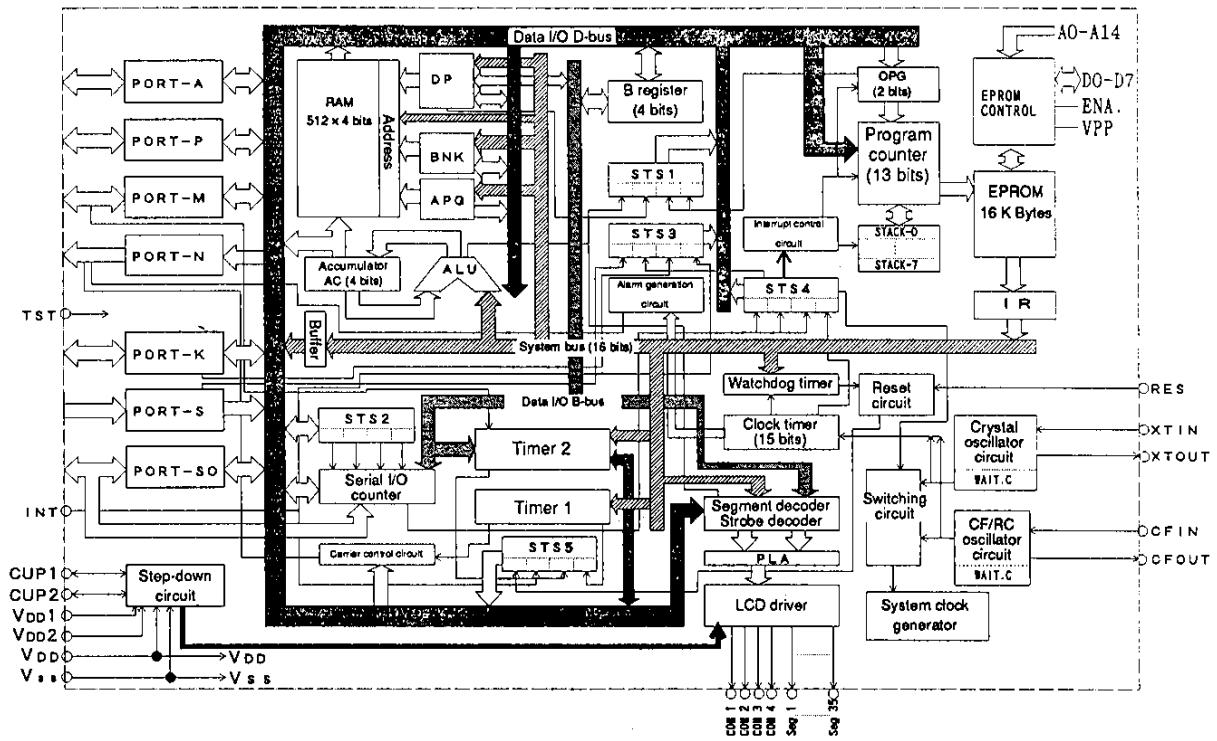

LC58E7008 System Block Diagram

- | | | | | | |
|-----|-----------------------------|------|------------------------|--------|---|
| RAM | : Data memory | B | : B register | STS4 | : Status register 4 |
| ROM | : Program memory | OPG | : ROM page flag | STS5 | : Status register 5 |
| DP | : Data pointer register | PC | : Program counter | PLA | : Program logic for segment data and stobes |
| BNK | : Bank register | IR | : Instruction register | WAIT.C | : Wait time counter |
| APG | : RAM page flag | STS1 | : Status register 1 | | |
| AC | : Accumulator | STS2 | : Status register 2 | | |
| ALU | : Arithmetic and logic unit | STS3 | : Status register 3 | | |

Pin Functions

Pin	I/O	QIP-80 Pin No.	Function	Option	At reset																									
V _{DD} V _{SS}	— —	24 23	Power supply																											
V _{DD1} V _{DD2}	— —	22 21	LCD drive power supply <table border="1" style="margin-left: 20px;"> <thead> <tr> <th></th> <th>NON</th> <th>1/1 bias</th> <th>1/2 bias</th> <th>1/3 bias</th> </tr> </thead> <tbody> <tr> <td>V_{DD}</td> <td></td> <td></td> <td></td> <td></td> </tr> <tr> <td>V_{DD1}</td> <td></td> <td></td> <td></td> <td></td> </tr> <tr> <td>V_{DD2}</td> <td></td> <td></td> <td></td> <td></td> </tr> <tr> <td>V_{SS}</td> <td></td> <td></td> <td></td> <td></td> </tr> </tbody> </table>		NON	1/1 bias	1/2 bias	1/3 bias	V _{DD}					V _{DD1}					V _{DD2}					V _{SS}						
	NON	1/1 bias	1/2 bias	1/3 bias																										
V _{DD}																														
V _{DD1}																														
V _{DD2}																														
V _{SS}																														
CUP1 CUP2	— —	3 4	Switching pin used to supply the LCD drive voltage to the VDD1 and VDD2 pins <ul style="list-style-type: none"> Connect a nonpolar capacitor between CUP1 and CUP2 when 1/2 or 1/3 bias is used. Leave open when a bias other than 1/2 or 1/3 is used. 																											
CFIN	Input	25	System clock oscillator connections <ul style="list-style-type: none"> Ceramic resonator connection (CF specifications) RC component connection (RC specifications) External signal input pin (CFOUT is left open) 	<ul style="list-style-type: none"> CF specifications Not used 																										
CFOUT	Output	26	This oscillator is stopped by the execution of a STOP or SLOW instruction.																											
XTIN	Input	20	Reference calculation (clock specifications, LCD alternation frequency), system clock oscillator <ul style="list-style-type: none"> 32 kHz crystal resonator connection 65 kHz crystal resonator connection 	<ul style="list-style-type: none"> 32k specifications 65k specifications 38k specifications Not used 																										
XTOUT	Output	19	This oscillator is stopped by the execution of a STOP instruction.																											
S1 S2 S3 S4	Input	27 28 29 30	Input-only ports <ul style="list-style-type: none"> Input pins used to read data into RAM Built-in 7.8 ms and 1.95 ms chatter exclusion circuits Built-in pull-up/pull-down resistors Note: The 7.8 ms and 1.95 ms times are the times when $\phi 0$ is 32.768 kHz.	<ul style="list-style-type: none"> Transistors to hold a low or high level Selection of either pull-up or pull-down resistors 	<ul style="list-style-type: none"> The pull-up or pull-down resistors are on. Note: These pins go to the floating state when reset is cleared. 																									
K1 K2 K3 K4	I/O	31 32 33 34	I/O ports <ul style="list-style-type: none"> Input pins used to read data into RAM Output pins used to output data from RAM Built-in 7.8 ms and 1.95 ms input-mode chatter exclusion circuits. The selection of 7.8 or 1.95 ms is linked to that for the S ports. Note: The 7.8 ms and 1.95 ms times are the times when $\phi 0$ is 32.768 kHz.	<ul style="list-style-type: none"> Transistors to hold a low or high level Selection of either pull-up or pull-down resistors 	<ul style="list-style-type: none"> The pull-up or pull-down resistors are on. Note: These pins go to the floating state when reset is cleared. Input mode Output latch data is set high. 																									
M1 M2 M3 M4	I/O	35 36 37 38	I/O ports <ul style="list-style-type: none"> Input pins used to read data into RAM Output pins used to output data from RAM M4 is used as the external clock input pin in TM2 mode 3. <ul style="list-style-type: none"> The minimum period for the external clock is twice the cycle time. Built-in pull-up/pull-down resistors 	The same as K1 to K4	The same as K1 to K4																									
A1 A2 A3 A4	I/O	11 12 13 14	I/O ports <ul style="list-style-type: none"> Input pins used to read data into RAM Output pins used to output data from RAM Built-in pull-up/pull-down resistors 	The same as K1 to K4	The same as K1 to K4																									
P1 P2 P3 P4	I/O	15 16 17 18	I/O ports Function: The same as pins A1 to A4	The same as K1 to K4	The same as K1 to K4																									

Continued on next page.

LC58E7008

Continued from preceding page.

Pin	I/O	QIP-80 Pin No.	Function	Option	At reset
SO1 SO2 SO3 SO4	I/O	7 8 9 10	I/O ports Function: The same as pins A1 to A4 Pins SO1 to SO3 area also used for the serial interface. • Use of these pins in serial mode can be selected under program control. • Pin functions: SO1: Serial input pin SO2: Serial output pin SO3: Serial clock pin The serial clock pin can be switched between internal and external, and between rising edge output and falling edge output.	• Transistors to hold a low or high level • Selection of either pull-up or pull-down resistors • Internal serial clock divisor selection I 1/1 II 1/2 III 1/4	The same as K1 to K4
N1 N2 N3 N4	Output	39 40 41 42	Output-only ports • Output pins used to output data from RAM • An alarm signal can be output from pin N4. (Note that this is only when the N4 output latch is low.) • An alarm signal modulated at 1, 2 or 4 kHz can be output. (These frequencies are output when $\theta 0$ is 32.768 kHz.) • A carrier signal can be output from N3. (Note that this is only when the N3 output latch is low.)	• Pin N1 to N4 output circuit type: I N-channel open drain • Pin N1 to N4 output level I High level II Low level	The output levels on pins N1 to N4 can be specified as an option.
INT	Input	6	Input ports • External interrupt request inputs • Input pins used to read data into RAM • Input detection can be performed on either rising or falling edges. • Built-in pull-up/pull-down resistors	• Transistors to hold a low or high level • Selection of either pull-up or pull-down resistors • Signal conversion (rising/falling) selection	
RES	Input	5	LSI reset input • The LC58E7008 resets on a high level input Note: • An external resistor is required. • The reset pulse must be at least 200 μ s.	* Only when the input resistor open specification is selected	
TST	Input	43	Test input Connect to V_{SS} in normal operation.		
Seg1, Seg2 to Seg35	Output	44, 45 to 78	• LCD panel drive/general-purpose output — LCD panel drive I STATIC II 1/2 bias – 1/2 duty III 1/2 bias – 1/3 duty IV 1/2 bias – 1/4 duty V 1/3 bias – 1/3 duty VI 1/3 bias – 1/4 duty Types I to V can be specified as mask options. — General purpose output mode I CMOS II P-channel open drain III N-channel open drain Types I to III can be specified as mask options. • LCD/general purpose output control is handled by the segment PLA, and thus program control is not required. • These pins support output latch control on reset and in standby states when the oscillators are stopped. • Arbitrary combinations of LCD drive and general purpose outputs can be used.	• LCD driver/general-purpose output switching • LCD drive type switching — STATIC — 1/2 bias – 1/2 duty — 1/2 bias – 1/3 duty — 1/2 bias – 1/4 duty — 1/3 bias – 1/3 duty — 1/3 bias – 1/4 duty • General-purpose output circuit switching — CMOS — P-channel open drain — N-channel open drain • Output latch control in standby modes	• LCD drive All segments off • General-purpose outputs Low level Note: When a combination of LCD drive and general-purpose outputs, the output state is either all segments off or low level. • These pins go to the V_{SS} level during the reset period.

Continued on next page.

LC58E7008

Continued from preceding page.

Pin	I/O	QIP-80 Pin No.	Function	Option	At reset																														
COM1 COM2 COM3 COM4	Output	2 1 80 79	LCD panel drive common polarity outputs The table below shows how these pins are used depending on the duty used. (Values for alternation frequency reflect a typical specification of 32.768 MHz for a0) <table border="1" style="margin-top: 10px;"> <thead> <tr> <th></th> <th>Static duty</th> <th>1/2 duty</th> <th>1/3 duty</th> <th>1/4 duty</th> </tr> </thead> <tbody> <tr> <td>COM1</td> <td style="text-align: center;">○</td> <td style="text-align: center;">○</td> <td style="text-align: center;">○</td> <td style="text-align: center;">○</td> </tr> <tr> <td>COM2</td> <td style="text-align: center;">×</td> <td style="text-align: center;">○</td> <td style="text-align: center;">○</td> <td style="text-align: center;">○</td> </tr> <tr> <td>COM3</td> <td style="text-align: center;">×</td> <td style="text-align: center;">×</td> <td style="text-align: center;">○</td> <td style="text-align: center;">○</td> </tr> <tr> <td>COM4</td> <td style="text-align: center;">×</td> <td style="text-align: center;">×</td> <td style="text-align: center;">×</td> <td style="text-align: center;">○</td> </tr> <tr> <td>Alternation frequency</td> <td style="text-align: center;">32 Hz</td> <td style="text-align: center;">32 Hz</td> <td style="text-align: center;">42.7 Hz</td> <td style="text-align: center;">32 Hz</td> </tr> </tbody> </table>		Static duty	1/2 duty	1/3 duty	1/4 duty	COM1	○	○	○	○	COM2	×	○	○	○	COM3	×	×	○	○	COM4	×	×	×	○	Alternation frequency	32 Hz	32 Hz	42.7 Hz	32 Hz		These pins are n-channel open-drain outputs during the reset period.
	Static duty	1/2 duty	1/3 duty	1/4 duty																															
COM1	○	○	○	○																															
COM2	×	○	○	○																															
COM3	×	×	○	○																															
COM4	×	×	×	○																															
Alternation frequency	32 Hz	32 Hz	42.7 Hz	32 Hz																															
Note: A cross (x) indicates that the pin is not used with that duty type.																																			

Usage Notes

The following tools and software are required when the LC58E7008 is used.

The LC587000 Series Software Development Tools: For creating programs and option data.

Note that only MS-DOS machines are supported as the development host machine. See the LC587000 Series Software Development Tools manuals for details on the use of these tools.

EC5878.EXE: This is a program that converts and merges program and option data for the LC587000 series so that it can be written to the LC58E7008 EPROM.

EPROM writing board (adapter socket: W58E68Q): This is a socket adapter that allows a general-purpose PROM writer to be used to write program data to the LC58E7008.

General purpose PROM writer: The EVA-520 programmer that comes with the LC587000 Series Software Development Tools cannot be used. A general purpose PROM writer must be used.

This section describes the procedures used with the LC58E7008 and the EC5876.EXE program, which is one of the tools mentioned above. More details on LC587000 Series program development are available in LC587000 Series Users Manual and the manuals for the LC587000 Series Development Tools and the general purpose PROM writer.

1. Procedure (This flowchart describes the procedure used.)

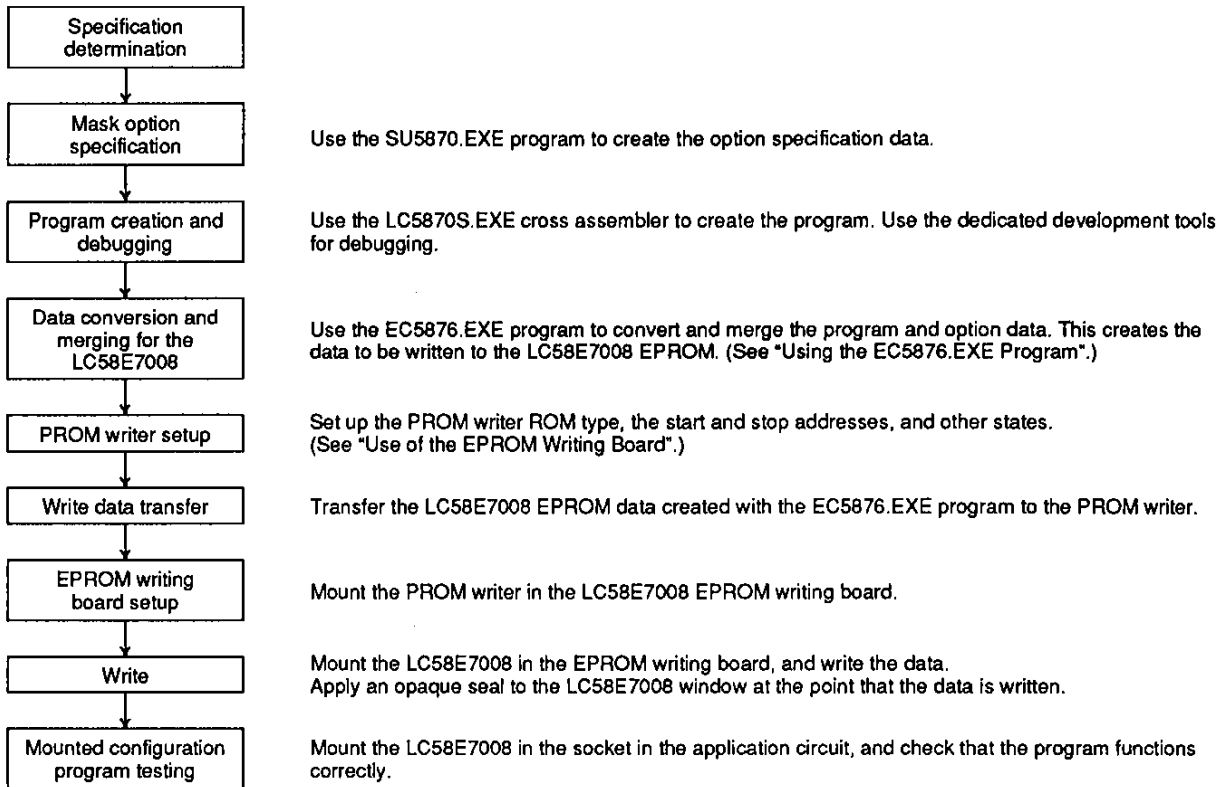

Note: There are differences in function and characteristics between the LC58E7008 and the LC587000 series mask ROM versions. Be sure to take these differences into account when testing the programmed LC58E7008. See the "Usage Notes" section for details on the differences.

2. Using the EC5876.EXE Program (Operation)

As shown in the figures below, the data to be written to the LC58E7008 consists of a program data area (instruction code area) and an option data area. The EC5876.EXE program applies a special conversion process to the option specification data to create the option data area data.

The EC5876.EXE program converts and merges program data and option data to create the data to be written to the LC58E7008.

• Start-up procedure

```
A:>EC5876 ROMSAMP.HEX PLASAMP.HEX EP-SAMP.HEX<ENT>
```

Or:

```
A:>EC5876<ENT>
```

```
*****
* LC58E76 PROGRAM & MASK OPTION CONVERSION Ver XXXXXX *
*****
```

```
ROM PROGRAM NAME : ROMSAMP.HEX<ENT>
```

```
PLA PROGRAM NAME : PLASAMP.HEX<ENT>
```

```
EP ROM WRITE NAME: EP-SAMP.HEX<ENT>
```

```
Program complete.....Program termination message
```

• Error messages

- Error ON filename.HEX, FILE NOT FOUND.....The file "filename.HEX" was not found.
The filename "filename.HEX" was incorrect.
- Error ON MAKE LC5876, 5874, 5873, 5872The ROM data and the option data object microcontroller type did not agree. The ROM data must be created with a cross assembler and option specification software designed for the same microcontroller type.
- Error ON filename.HEX, EOF NOT DETECTEDA hexadecimal record end marker was not found in the file "filename.HEX".
- Error ON filename.HEX, ILLEGAL CHARACTER.....A character other than 0 to 9 or A to F was found in a hexadecimal context while reading the file "filename.HEX".
- Error ON filename.HEX, ADDRESS OVER.....An address in the file "filename.HEX" exceeded the allowed range.
- Error ON filename.HEX, ILLEGAL FILEHDRThe header in the file "filename.HEX" is not for the LC5870 series.
There was an error in the hexadecimal file specification.
- Error ON command line input,
INVALID NUMBER OF PARAMETERSThe number of parameters in the command line was inappropriate.
- Error ON ILLEGAL, MASK OPTION DATAThere was an error in the mask option data.

• EPROM data structure

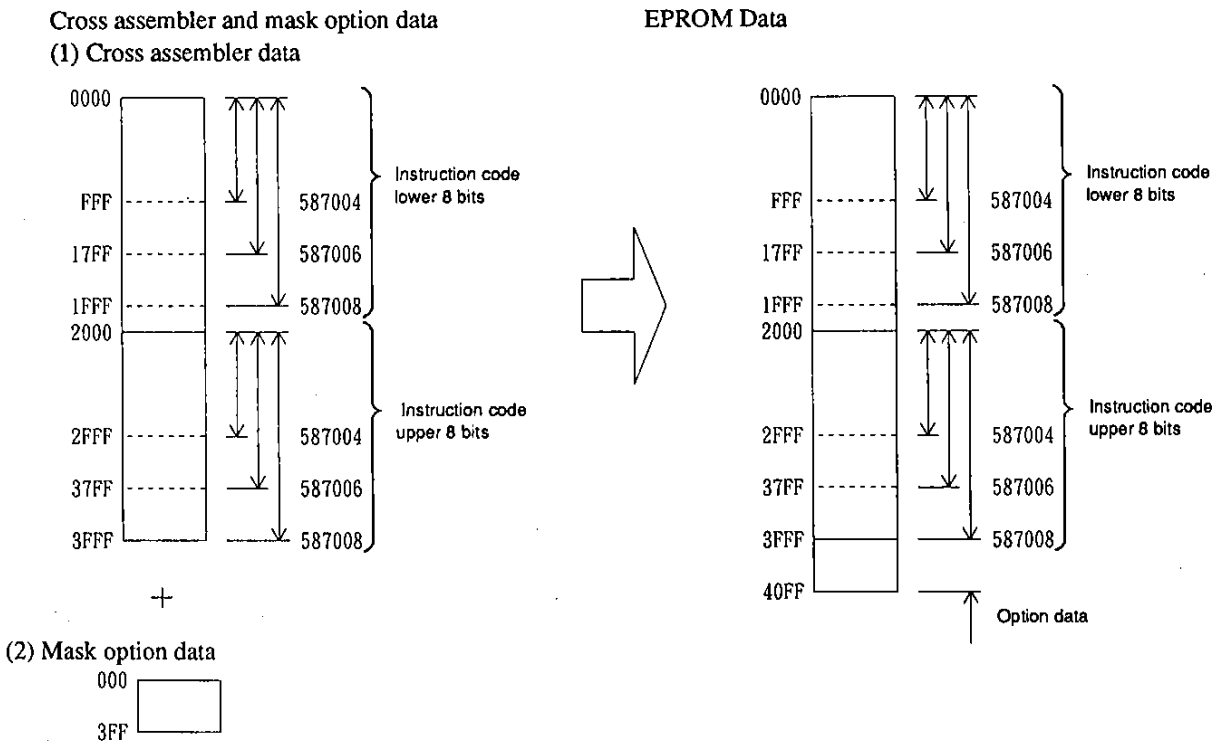

LC58E7008

3. Use of the W58E68Q EPROM Writing Board (Board used with both the LC58E68 and the LC58E76)
The EPROM writing board is a socket adapter that fits the LC58E7008 to the device socket in a general-purpose PROM writer.

- EPROM Writing Board Appearance

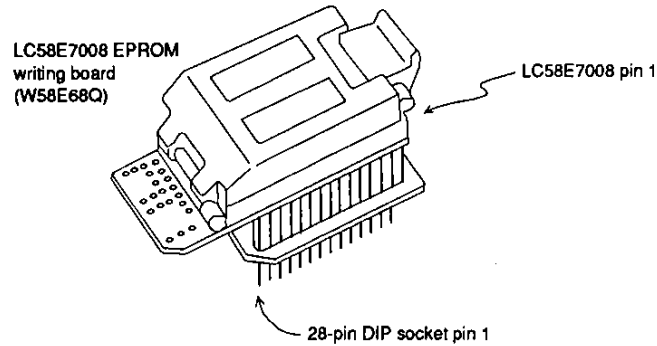

- PROM writer settings

- ROM type: 256 K, VPP = 21 V mode
- Start and stop addresses: Set these to 0000H and 40FFH.

4. Erasing LC58E7008 EPROM Data

Use a general purpose EPROM eraser to erase data written to an LC58E7008.

5. Notes On Order Mask ROM

- The following methods cannot be used to order LC587000 Series mask ROM products.

- Use of ".HEX" files that were converted and merged for use in an LC58E7008
- Use of an LC58E7008 itself

- Ordering mask ROM

- Use the program hexadecimal data generated by the cross assembler.
- Use the option hexadecimal data generated by the option specification software.
- Provide three EPROMs to which the program hexadecimal data has been written using a general purpose EPROM writer.
- Provide three EPROMs to which the option hexadecimal data has been written using a general purpose EPROM writer.

Specifications

The electrical characteristics listed here are provisional values and are subject to change.

Absolute Maximum Ratings at $V_{SS} = 0\text{ V}$, $T_a = 25^\circ\text{C}$

Parameter	Symbol	Condition/Pin	Rating			Unit	
			min	typ	max		
Maximum supply voltage	V_{DD}		-0.3		+6.0	V	
	V_{DD1}		-0.3		V_{DD}	V	
	V_{DD2}		-0.3		V_{DD}	V	
Maximum input voltage	V_I (1)	As allowed in the specified circuit (figure 1) XTIN, CFIN	Allowed up to the voltage that appears				
	V_I (2)	S1 - 4, K1 - 4, P1 - 4, SO1 - 4, A1 - 4, RES, INT, TST (K, P, M, SO and A ports in input mode)	-0.3		V_{DD} +0.3	V	
Maximum output voltage	V_O (1)	As allowed in the specified circuit (figure 1) XTOUT, CFOUT	Allowed up to the voltage that appears				
	V_O (2)	K1 - 4, P1 - 4, SO1 - 4, A1 - 4, N1 - 4, CUP1, CUP2, Seg1 - 35, COM1 - 4, (K, P, M, SO and A ports in output mode)	-0.3		V_{DD} +0.3	V	
	V_O (3)	Open drain specifications		N1 to N4 (n-channel)	+13	V	
Output pin current	I_O (1)	Per pin	N1 - 4		0	15	mA
	I_O (2)	Per pin	N1 - 4		-10	0	mA
	I_O (3)	Per pin	K1 - 4, P1 - 4, M1 - 4, SO1 - 4,		0	5	mA
	I_O (4)	Per pin	A1 - 4		-5	0	mA
	ΣI_O (1)	Total (summed) pin current	K1 - 4, P1 - 4, M1 - 4, SO1 - 4, A1 - 4, N1 - 4,			70	mA
	ΣI_O (2)	Total (summed) pin current	Seg1 - 35		-70		mA
Allowable power dissipation	P_{dmax}	For the QFC80 window ceramic flat package				500	mW
Operating temperature	T_{opr}				10	40	$^\circ\text{C}$
Storage temperature	T_{stg}				-55	+125	$^\circ\text{C}$

Allowable Operating Ranges at $V_{SS} = 0\text{ V}$, $T_a = 25^\circ\text{C}$

Parameter	Symbol	Condition/Pin	Rating			Unit
			min	typ	max	
Supply voltage	V_{DD}	No LCD specifications: $V_{DD1} = V_{DD2} = V_{DD}$ Static drive specifications: $V_{DD1} = V_{DD2} = V_{DD}$ 1/2 bias specifications: $V_{DD1} = V_{DD2} = 1/2V_{DD}$ 1/3 bias specifications: $V_{DD1} = 2 \times 1/3V_{DD}$ $V_{DD2} = 1/3V_{DD}$	2.8		5.5	V
Data retention supply voltage	V_{HD}	RAM and register contents retention voltage*	2.8		V_{DD}	V
Input high level voltage	V_{IH1}	S1 - 4, K1 - 4, P1 - 4, M1 - 4, SO1 - 4, A1 - 4, INT (K, P, M, SO and A ports in input mode)	$0.7 V_{DD}$		V_{DD}	V
Input low level voltage	V_{IL1}		0		$0.3 V_{DD}$	V
Input high level voltage	V_{IH2}	RES pin	$0.75 V_{DD}$		V_{DD}	V
Input low level voltage	V_{IL2}		0		$0.25 V_{DD}$	V
Input high level voltage	V_{IH3}	CFIN pin	$0.75 V_{DD}$		V_{DD}	V
Input low level voltage	V_{IL3}		0		$0.25 V_{DD}$	V
Operating frequency 1	fopg1	$V_{DD} = 2.8$ to 5.5 V , 32 kHz	XTIN/XTOUT crystal oscillator	32	33	kHz
Operating frequency 2	fopg2	$V_{DD} = 2.8$ to 5.5 V , 38 kHz		37	39	kHz
Operating frequency 3	fopg3	$V_{DD} = 2.8$ to 5.5 V , 65 kHz		60	70	kHz
Operating frequency 4	fopg4	$V_{DD} = 2.8$ to 5.5 V	CFIN/CFOUT CF specifications	190	1200	kHz
Operating frequency 5	fopg5	$V_{DD} = 3.0$ to 5.5 V		190	2300	kHz
Operating frequency 6	fopg6	$V_{DD} = 4.5$ to 5.5 V		190	4200	kHz
Operating frequency 7	fopg7	$V_{DD} = 3.0$ to 5.5 V	Pins SO1 and SO3 (in serial mode) The rising and falling edges of input signal and clock waveforms must be $\leq 10\ \mu\text{s}$.	DC	200	kHz

Note: * In a state with the CF/RC oscillator and the crystal oscillator completely stopped, and all internal circuits stopped

Electrical Characteristics at $V_{DD} = 2.8$ to 3.2 V , $V_{SS} = 0\text{ V}$, $T_a = 25^\circ\text{C}$

Parameter	Symbol	Condition/Pin	Rating			Unit
			min	typ	max	
Input resistance	$R_{IN1\ A}$	$V_{IN} = 0.2 V_{DD}$, Low-level hold transistor *, Figure 2	60	300	1200	k Ω
	$R_{IN1\ B}$	$V_{IN} = V_{DD}$, Pull-down resistor *, Figure 2	30	150	500	k Ω
	$R_{IN1\ C}$	$V_{IN} = 0.8 V_{DD}$, High-level hold transistor *, Figure 2	60	300	1200	k Ω
	$R_{IN1\ D}$	$V_{IN} = V_{SS}$, Pull-up resistor *, Figure 2	30	150	500	k Ω
	$R_{IN2\ A}$	$V_{IN} = 0.2 V_{DD}$, INT low-level hold transistor	60	300	1200	k Ω
	$R_{IN2\ B}$	$V_{IN} = V_{DD}$, INT pull-down resistor	300	1500	5000	k Ω
	$R_{IN2\ C}$	$V_{IN} = 0.8 V_{DD}$, INT high-level hold transistor	60	300	1200	k Ω
	$R_{IN2\ D}$	$V_{IN} = V_{SS}$, INT pull-up resistor	300	1500	5000	k Ω
	R_{IN3}	$V_{IN} = V_{DD}$, With a pull-down resistor on the TST pin	20	70	300	k Ω
Output low level voltage	$V_{OL} (1)$	$I_{OL} = 1.0\text{ mA}$	N1 - 4		0.5	V
Output high level voltage	$V_{OH} (2)$	$I_{OH} = -400\ \mu\text{A}$	K1 - 4, P1 - 4, M1 - 4, SO1 - 4, A1 - 4 (K, P, M, SO and A ports in output mode)	$V_{DD} - 0.5$		V
Output low level voltage	$V_{OL} (2)$	$I_{OL} = 400\ \mu\text{A}$			0.5	V
Output off leakage current	I_{OFF}	$V_{OH} = 10.5\text{ V}$	N1 - 4, Figure 10		1.0	μA
Segment port output impedance • When CMOS output ports are used						
Output high level voltage	$V_{OH} (3)$	$I_{OH} = -100\ \mu\text{A}$	Seg 1 to 35	$V_{DD} - 0.5$		V
Output low level voltage	$V_{OL} (3)$	$I_{OL} = 100\ \mu\text{A}$			0.5	V

Note: * The 24 pins S1 to S4, K1 to K4, P1 to P4, M1 to M4, SO1 to SO4 and A1 to A4.

Continued on next page.

LC58E7008

Continued from preceding page.

Parameter	Symbol	Condition/Pin	Rating			Unit	
			min	typ	max		
• When p-channel open drain output ports are used (See figure 11.)							
Output high level voltage	$V_{OH(3)}$	$I_{OH} = -100 \mu A$	Seg 1 to 35	$V_{DD} - 0.5$		V	
Output off leakage current	I_{OFF}	$V_{OL} = V_{SS}$				1.0	μA
• When n-channel open drain output ports are used (See figure 11.)							
Output low level voltage	$V_{OL(3)}$	$I_{OL} = 100 \mu A$	Seg 1 to 35			0.5 V	
Output off leakage current	I_{OFF}	$V_{OH} = V_{DD}$				1.0	μA
• Static drive							
Output high level voltage	$V_{OH(4)}$	$I_{OH} = -20 \mu A$	Seg 1 to 35	$V_{DD} - 0.2$		V	
Output low level voltage	$V_{OL(4)}$	$I_{OL} = 20 \mu A$				0.2 V	
Output high level voltage	$V_{OH(5)}$	$I_{OH} = -100 \mu A$	COM1	$V_{DD} - 0.2$		V	
Output low level voltage	$V_{OL(5)}$	$I_{OL} = 100 \mu A$				0.2 V	
• 1/2 bias							
Output high level voltage	$V_{OH(4)}$	$I_{OH} = -20 \mu A$	Seg 1 to 35	$V_{DD} - 0.2$		V	
Output low level voltage	$V_{OL(4)}$	$I_{OL} = 20 \mu A$				0.2	V
Output high level voltage	$V_{OH(6)}$	$I_{OH} = -100 \mu A$	COM1 - 4	$V_{DD} - 0.2$		V	
Output middle level voltage	V_{OM2-1}	$I_{OH} = -100 \mu A$ $I_{OL} = 100 \mu A$		$V_{DD}/2 - 0.2$		$V_{DD}/2 + 0.2$	V
Output low level voltage	$V_{OL(6)}$	$I_{OL} = 100 \mu A$				0.2	V
• 1/3 bias							
Output high level voltage	$V_{OH(4)}$	$I_{OH} = -20 \mu A$	Seg 1 to 35	$V_{DD} - 0.2$		V	
Output middle level voltage	V_{OM1-1}	$I_{OH} = -20 \mu A$		$2V_{DD}/3 - 0.2$		$2V_{DD}/3 + 0.2$	V
	V_{OM1-2}	$I_{OL} = 20 \mu A$		$V_{DD}/3 - 0.2$		$V_{DD}/3 + 0.2$	V
Output low level voltage	$V_{OL(4)}$	$I_{OL} = 20 \mu A$				0.2	V
Supply leakage current	$I_{LEK(1)}$	$V_{DD} = 3.0 V$	$T_a = 25^\circ C$, STOP mode, Figure 3		1.0	μA	
Input leakage current	I_{OFF}	$V_{DD} = 3.0 V$	S1 - 4, K1 - 4, P1 - 4, M1 - 4, SO1 - 4, A1 - 4, INT, RES (K, P, M, SO and A ports in input mode, INT and RES pin open specifications)				
		$V_{IN} = V_{DD}$				1.0	μA
		$V_{IN} = V_{SS}$		-1.0		μA	
Output voltage 1	$V_{DD1-(1)}$	$V_{DD} = 3.0 V$, $C_1 = C_2 = 0.1 \mu F$ 1/2 bias, $f_{opg} = 32.768 kHz$, Figure 4	$V_{DD1} = V_0$		1.5	V	
Output voltage 2	$V_{DD2-(1)}$	$V_{DD} = 3.0 V$, $C_1 = C_2 = 0.1 \mu F$ 1/3 bias, $f_{opg} = 32.768 kHz$, Figure 4	$V_{DD1} = V_0$		2.0	V	
	$V_{DD2-(2)}$		$V_{DD2} = V_0$		1.0	V	
Supply current 1	I_{DD1}	$V_{DD} = 3.0 V$	$T_a = 25^\circ C$, Crystal oscillator specifications, Crystal: 32 kHz, $C_g = 20 pF$, $C_l = 25 k\Omega$, HALT mode, LCD at 1/3 bias, Figure 6		5.0	μA	
Supply current 2	I_{DD2}	$V_{DD} = 3.0 V$	$T_a = 25^\circ C$, Crystal oscillator specifications, Crystal: 38 kHz or 65 kHz, $C_g = 10 pF$, $C_l = 25 k\Omega$, HALT mode, LCD at 1/3 bias, Figure 6		10.0	μA	
Supply current 3	I_{DD3}	$V_{DD} = 3.0 V$	$T_a = 25^\circ C$, CF oscillator specifications, CF: 400 kHz, $C_{cg} = C_{cd} = 330 pF$, HALT mode, LCD at 1/3 bias, Figure 7		150	μA	
Supply current 4	I_{DD4}	$V_{DD} = 3.0 V$	$T_a = 25^\circ C$, CF oscillator specifications, CF: 1 MHz, $C_{cg} = C_{cd} = 100 pF$, HALT mode, LCD at 1/3 bias, Figure 8		200	μA	

Continued on next page.

Continued from preceding page.

Parameter	Symbol	Condition/Pin	Rating			Unit
			min	typ	max	
Oscillator start time	TSTT	V _{DD} = 2.8 V Crystal oscillator specifications, with a 32 kHz crystal C _I ≤ 25 kΩ, C _g = 20 pF			5	s
Oscillator stabilization degree	Δf	V _{DD} = 2.95 to 3.05 V Figure 6			3	ppm
Oscillator start time	TSTT	V _{DD} = 2.8 V Crystal oscillator specifications, with a 38 or 65 kHz crystal XC _g = 10 pF, C _I ≤ 25 kΩ Figure 6			5	s
Oscillator start time	TSTT	V _{DD} = 2.8 V CF oscillator specifications, with a 400 kHz CF used C _{cg} = C _{cd} = 330 pF, Figure 7			30	ms
Oscillator start time	TSTT	V _{DD} = 2.8 V CF oscillator specifications, with an 800 kHz CF used C _{cg} = C _{cd} = 220 pF or 100 pF Figure 7			30	ms
Oscillator compensation capacitance	C _d	V _{DD} = 3.0 V XTOUT pin (built-in)		20		pF

Electrical Characteristics at V_{DD} = 4.5 to 5.5 V, V_{SS} = 0 V, Ta = 25°C

Parameter	Symbol	Condition/Pin	Rating			Unit
			min	typ	max	
Input resistance	R _{IN1 A}	V _{IN} = 0.2 V _{DD} , Low level hold transistor *, Figure 2	30	120	500	kΩ
	R _{IN1 B}	V _{IN} = V _{DD} , Pull-down resistor *, Figure 2	10	50	200	kΩ
	R _{IN1 C}	V _{IN} = 0.8 V _{DD} , High level hold transistor *, Figure 2	30	120	500	kΩ
	R _{IN1 D}	V _{IN} = V _{SS} , Pull-up resistor *, Figure 2	10	50	200	kΩ
	R _{IN2 A}	V _{IN} = 0.2 V _{DD} , INT low level hold transistor	30	120	500	kΩ
	R _{IN2 B}	V _{IN} = V _{DD} , INT pull-down resistor	100	500	2000	kΩ
	R _{IN2 C}	V _{IN} = 0.8 V _{DD} , INT high level hold transistor	30	120	500	kΩ
	R _{IN2 D}	V _{IN} = V _{SS} , INT pull-up resistor	100	500	2000	kΩ
	R _{IN3}	V _{IN} = V _{DD} , With a pull-down resistor on the TST pin	20	70	300	kΩ
Output low level voltage	V _{OL} (1)	I _{OL} = 10.0 mA N1 - 4			0.5	V
Output high level voltage	V _{OH} (2)	I _{OH} = -1.0 mA K1 - 4, P1 - 4, M1 - 4, SO1 - 4, A1 - 4	V _{DD} - 0.5	V _{DD} - 0.2		V
Output low level voltage	V _{OL} (2)	I _{OL} = 2.0 mA (K, P, M, SO and A ports in output mode)		0.2	0.5	V
Output off leakage current	I _{OFF}	V _{OH} = 10.5 V N1 - 4, Figure 10			1.0	μA
Segment port output impedance						
• When CMOS output ports are used						
Output high level voltage	V _{OH} (3)	I _{OH} = -500 μA Seg 1 to 35	V _{DD} - 0.5	V _{DD} - 0.2		V
Output low level voltage	V _{OL} (3)	I _{OL} = 500 μA			0.5	V
• When p-channel open drain output ports are used (See figure 11.)						
Output high level voltage	V _{OH} (4)	I _{OH} = -500 μA Seg 1 to 35	V _{DD} - 0.5	V _{DD} - 0.2		V
Output off leakage current	I _{OFF}	V _{OL} = V _{SS}			1.0	μA
• When n-channel open drain output ports are used (See figure 11.)						
Output low level voltage	V _{OL} (4)	I _{OL} = 500 μA Seg 1 to 35		0.2	0.5	V
Output off leakage current	I _{OFF}	V _{OH} = V _{DD}			1.0	μA
• Static drive						
Output high level voltage	V _{OH} (4)	I _{OH} = -40 μA Seg 1 to 35	V _{DD} - 0.2			V
Output low level voltage	V _{OL} (4)	I _{OL} = 40 μA			0.2	V
Output high level voltage	V _{OH} (6)	I _{OH} = -400 μA COM1	V _{DD} - 0.2			V
Output low level voltage	V _{OL} (6)	I _{OL} = 400 μA			0.2	V

Note: * The 24 pins S1 to S4, K1 to K4, P1 to P4, M1 to M4, SO1 to SO4 and A1 to A4.

Continued on next page.

LC58E7008

Continued from preceding page.

Parameter	Symbol	Condition/Pin	Rating			Unit	
			min	typ	max		
• 1/2 bias							
Output high-level voltage	V_{OH} (4)	$I_{OH} = -40 \mu A$	Seg 1 to 35	$V_{DD} - 0.2$		V	
Output low-level voltage	V_{OL} (4)	$I_{OL} = 40 \mu A$				0.2	V
Output high-level voltage	V_{OH} (6)	$I_{OH} = -400 \mu A$	COM1 - 4	$V_{DD} - 0.2$		V	
Output middle-level voltage	V_{OM2-1}	$I_{OH} = -400 \mu A$ $I_{OL} = 400 \mu A$		$V_{DD}/2 - 0.2$		$V_{DD}/2 + 0.2$	V
Output low-level voltage	V_{OL} (6)	$I_{OL} = 400 \mu A$				0.2	V
• 1/3 bias							
Output high-level voltage	V_{OH} (4)	$I_{OH} = -40 \mu A$	Seg 1 to 35	$V_{DD} - 0.2$		V	
Output middle-level voltage	V_{OM1-1}	$I_{OH} = -40 \mu A$ $I_{OL} = 40 \mu A$		$2V_{DD}/3 - 0.2$		$2V_{DD}/3 + 0.2$	V
	V_{OM1-2}			$V_{DD}/3 - 0.2$		$V_{DD}/3 + 0.2$	V
Output low-level voltage	V_{OL} (4)	$I_{OL} = 40 \mu A$			0.2	V	
Output high-level voltage	V_{OH} (6)	$I_{OH} = -400 \mu A$	COM1 - 4	$V_{DD} - 0.2$		V	
Output middle-level voltage	V_{OM2-1}	$I_{OH} = -400 \mu A$ $I_{OL} = 400 \mu A$		$2V_{DD}/3 - 0.2$		$2V_{DD}/3 + 0.2$	V
	V_{OM2-2}			$V_{DD}/3 - 0.2$		$V_{DD}/3 + 0.2$	V
Output low-level voltage	V_{OL} (6)	$I_{OL} = 400 \mu A$			0.2	V	
Supply leakage current	I_{LEK} (1)	$V_{DD} = 5.5 V$	$T_a = 25^\circ C$, Stop mode, Figure 3		1.0	μA	
Input leakage current	I_{OFF}	$V_{DD} = 5.5 V$	$V_{IN} = V_{DD}$	S1 - 4, K1 - 4, M1 - 4, SO1 - 4, A1 - 4, INT, RES (K, P, M, SO and A ports in input mode, INT and RES pin open specifications)	1.0	μA	
			$V_{IN} = V_{SS}$		-1.0	μA	
Output voltage 1	V_{DD1-1}	$V_{DD} = 5.0 V$, $C1 = C2 = 0.1 \mu F$, 1/2 bias, fopg = 32.768 kHz	$V_{DD1} = V_0$ Figure 4		2.5	V	
Output voltage 2	V_{DD2-1}	$V_{DD} = 5.0 V$, $C1 = C2 = 0.1 \mu F$, 1/3 bias, fopg = 32.768 kHz	$V_{DD1} = V_0$ $V_{DD2} = V_0$ Figure 4		3.33	V	
	V_{DD2-2}				1.67	V	
Supply current 1	I_{DD1}	$V_{DD} = 5.0 V$	$T_a = 25^\circ C$, Crystal oscillator specifications, Crystal: 32 kHz, $C_g = 20 pF$, $C_l = 25 k\Omega$ HALT mode, LCD at 1/3 bias, Figure 6		20	μA	
Supply current 2	I_{DD2}	$V_{DD} = 5.0 V$	$T_a = 25^\circ C$, Crystal oscillator specifications, Crystal: 38 kHz or 65 kHz, $C_g = 10 pF$, $C_l = 25 k\Omega$, HALT mode, LCD at 1/3 bias, Figure 6		30	μA	
Supply current 3	I_{DD3}	$V_{DD} = 5.0 V$	$T_a = 25^\circ C$, CF oscillator specifications, CF: 400 kHz, $C_{cg} = C_{cd} = 330 pF$ HALT mode, LCD at 1/3 bias, Figure 7		400	μA	
Supply current 4	I_{DD4}	$V_{DD} = 5.0 V$	$T_a = 25^\circ C$, CF oscillator specifications, CF: 1 MHz, $C_{cg} = C_{cd} = 100 pF$, HALT mode, LCD at 1/3 bias, Figure 8		450	μA	
Supply current 5	I_{DD5-1}	$V_{DD} = 5.0 V$	$T_a = 25^\circ C$, CF oscillator specifications, CF: 2 MHz, $C_{cg} = C_{cd} = 33 pF$, HALT mode, LCD at 1/3 bias, Figure 8		500	μA	
Supply current 6	I_{DD6-1}	$V_{DD} = 5.0 V$	$T_a = 25^\circ C$, CF oscillator specifications, CF: 4 MHz, $C_{cg} = C_{cd} = 33 pF$, HALT mode, LCD at 1/3 bias, Figure 8		700	μA	
Oscillator compensation capacitance	C_d	$V_{DD} = 5.0 V$	XTOUT pin (built-in)		20	pF	

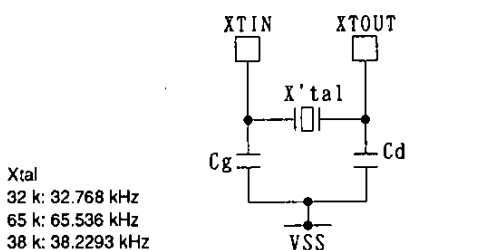

Xtal
 32 k: 32.768 kHz
 65 k: 65.536 kHz
 38 k: 38.2293 kHz

Figure 1-(1) Specified Oscillator Circuit (XT pin)

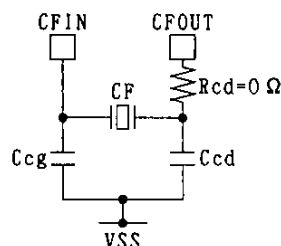

Figure 1-(2) Specified Oscillator Circuit (CF pin)

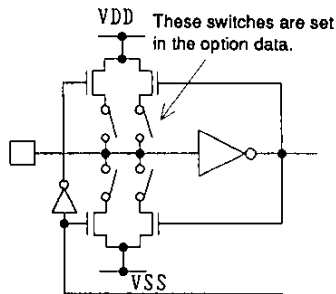
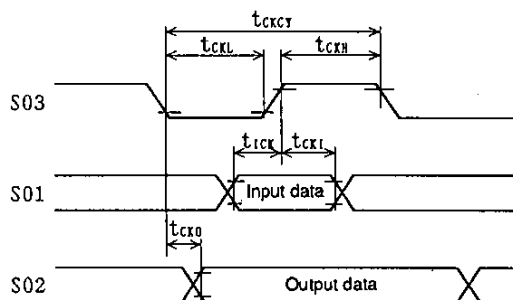

Figure 2 S, K, P, M, SO and A Port Input Circuit

(Reference)
 Recommended Ceramic Resonators for Mask ROM Versions

Manufacturer Item	Murata Mfg. Co., Ltd.			Kyocera Corporation		
	Type No.	Ccg (pF)	Ccd (pF)	Type No.	Ccg (pF)	Ccd (pF)
400 kHz	CSB400P	330	330	KBR-400B	330	330
800 kHz	CSB800J	220	220	KBR-800H	100	100
1 MHz	CSB1000J	220	220	KBR-1000H	100	100
2 MHz	CSA2.00MG, CST2.00MG	33	33	KBR-2.00MS	33	33
4 MHz	CSA4.00MG, CST4.00MG	33	33	KBR-4.00MS	33	33



tckcy	5 μs	MIN
tckl = tckh	2.4 μs	MIN
t1cx	1 μs	MIN
t1cx1	1 μs	MIN
t1cx0	1 μs	MAX
VDD=3.0~5.5V		

Figure 13 Serial I/O Timing
 (in external clock mode)

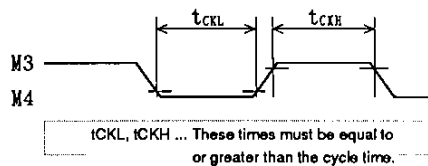

Figure 14 Timer 2 External Clock Input Timing
 (in external clock mode: pin M4)

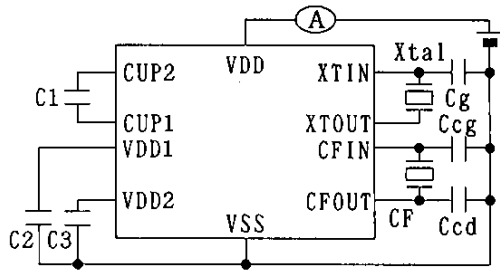

Figure 3 Supply Leakage Current Test Circuit

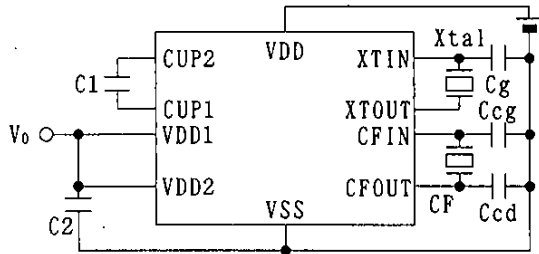
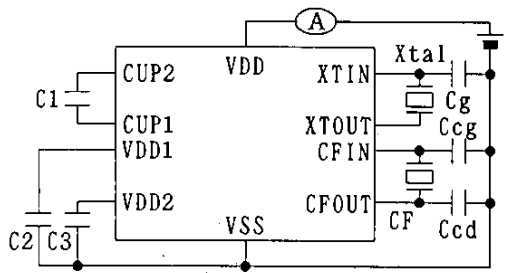
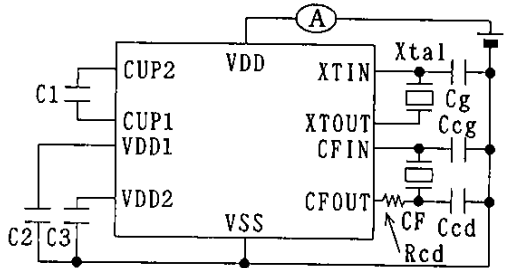

Figure 4 Output Voltage Test Circuit



Note: With the CF oscillator stopped
With a 32, 38, or 65 kHz crystal
C1, C2, C3: 0.1 μ F

Figure 6 Supply Current Test Circuit



Note: The crystal is in the oscillator stopped state

Figure 8 Supply Current Test Circuit

Figure 3

- In the stop state
- With the S-port input resistors on
- With the I/O ports in output mode with high level data values
- With the INT pin built-in resistor connected and in the open state
- With an external pull-down resistor on the RES pin
- The LCD-port values do not include the external component currents.
- With a crystal frequency between 32 and 65 kHz
- With CF between 200 kHz and 4 MHz

Figures 4 and 5

- With a crystal frequency of 32 kHz
- C1, C2, and C3 are 0.1 μ F capacitors.
- With the LCD ports open
- With CD between 200 kHz and 4 MHz

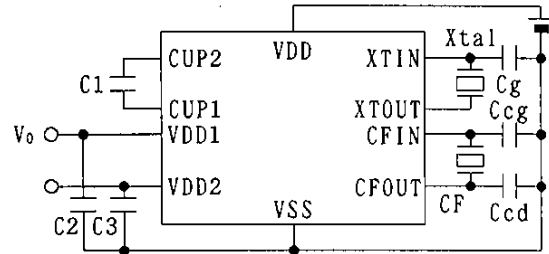

Figure 5 Output Voltage Test Circuit

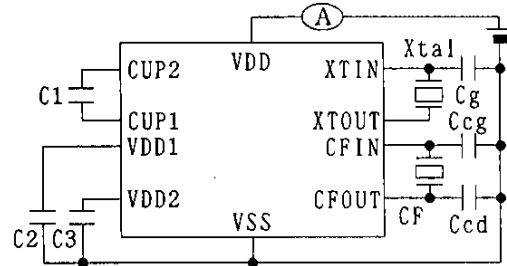

Figure 7 Supply Current Test Circuit

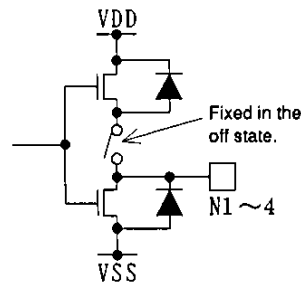

Figure 10 Pin N1 to Pin N4 Circuits

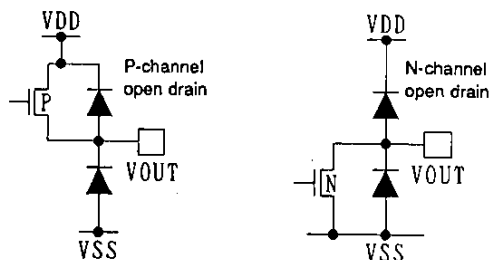

Figure 11 Segment Pin Open Drain Circuits

- No products described or contained herein are intended for use in surgical implants, life-support systems, aerospace equipment, nuclear power control systems, vehicles, disaster/crime-prevention equipment and the like, the failure of which may directly or indirectly cause injury, death or property loss.
- Anyone purchasing any products described or contained herein for an above-mentioned use shall:
 - ① Accept full responsibility and indemnify and defend SANYO ELECTRIC CO., LTD., its affiliates, subsidiaries and distributors and all their officers and employees, jointly and severally, against any and all claims and litigation and all damages, cost and expenses associated with such use:
 - ② Not impose any responsibility for any fault or negligence which may be cited in any such claim or litigation on SANYO ELECTRIC CO., LTD., its affiliates, subsidiaries and distributors or any of their officers and employees jointly or severally.
- Information (including circuit diagrams and circuit parameters) herein is for example only; it is not guaranteed for volume production. SANYO believes information herein is accurate and reliable, but no guarantees are made or implied regarding its use or any infringements of intellectual property rights or other rights of third parties.