

1A THREE TERMINAL NEGATIVE VOLTAGE REGULATORS
-5V, -6V, -8V, -9V, -10V, -12V, -15V, -18V, -20V, -24V

FEATURES:

- Suitable for C-MOS, TTL, and the other digital IC power supply.
- Internal thermal overload protecting.
- Internal short circuit current limiting.
- Output current in excess of 1.0A.

MAXIMUM RATINGS (Ta=25°C)

CHARACTERISTIC		SYMBOL	RATING	UNIT
Input Voltage	KIA7905P/PI~ KIA7915P/PI	V _{IN}	-35	V
	KIA7918P/PI~ KIA7924P/PI		-40	
Power Dissipation (Tc=25°C)	P _D	20.8	W	
Operating Junction Temperature	T _j	-30~150	°C	
Operating Temperature	T _{opr}	-30~75	°C	
Storage Temperature	T _{stg}	-55~150	°C	

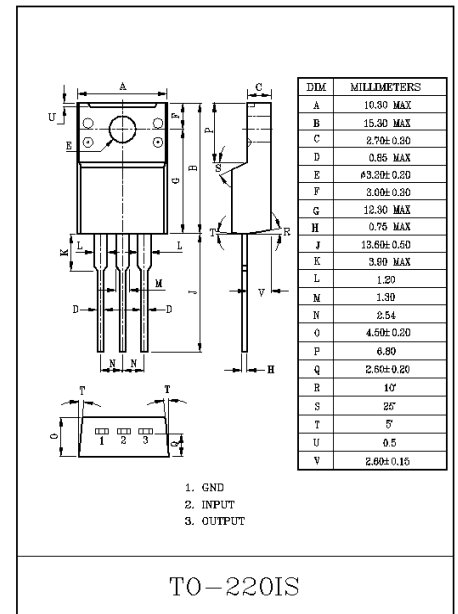
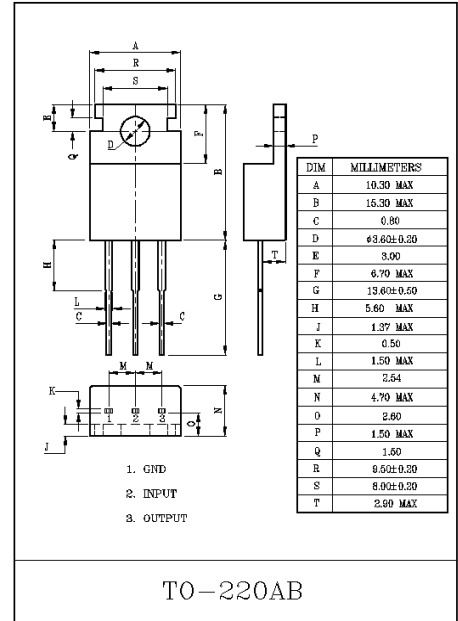

KIA7905P/PI ~ KIA7924P/PI

EQUIVALENT CIRCUIT

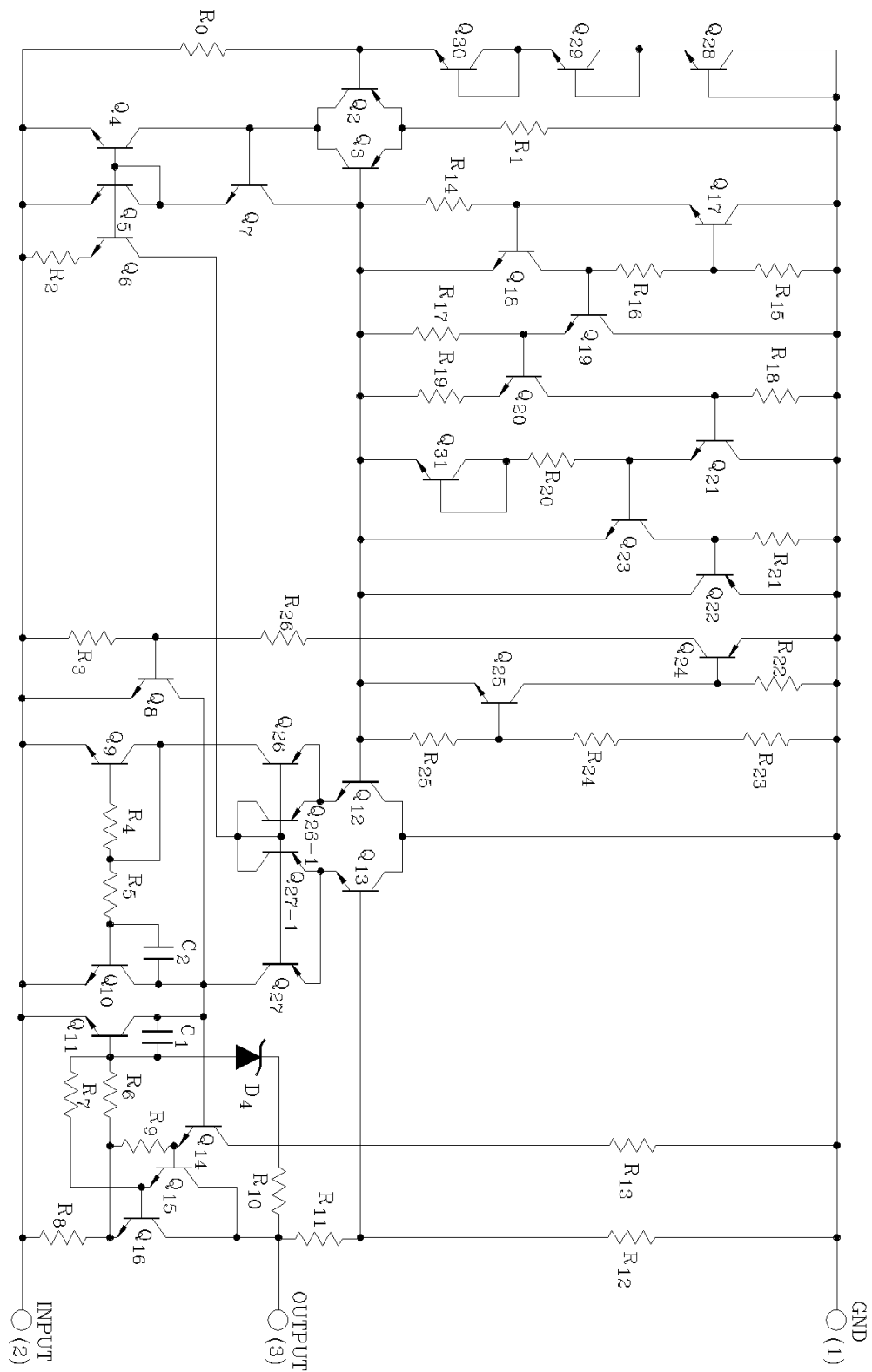

KIA7905P/PI ~ KIA7924P/PI

ELECTRICAL CHARACTERISTICS

KIA7905P/PI

(Unless otherwise specified, $V_{IN} = -10V$, $I_{OUT} = 500mA$, $0^{\circ}C \leq T_j \leq 125^{\circ}C$, $C_{IN} = 2.2\mu F$, $C_{OUT} = 1\mu F$)

CHARACTERISTIC	SYMBOL	TEST CIRCUIT	TEST CONDITION	MIN.	TYP.	MAX.	UNIT	
Output Voltage	V_{OUT}	1	$T_j = 25^{\circ}C$	-5.2	-5.0	-4.8	V	
Input Regulation	Reg line	1	$T_j = 25^{\circ}C$	$-12V \leq V_{IN} \leq -8V$	-	5	50	mV
				$-25V \leq V_{IN} \leq -7V$	-	10	100	
Load Regulation	Reg load	1	$T_j = 25^{\circ}C$	$5mA \leq I_{OUT} \leq 1.5A$	-	10	100	mV
				$250mA \leq I_{OUT} \leq 750mA$	-	3	50	
Output Voltage	V_{OUT}	1	$-20V \leq V_{IN} \leq -7V$ $5mA \leq I_{OUT} \leq 1.0A$	-5.25	-5.0	-4.75	V	
Quiescent Current	I_B	1	$T_j = 25^{\circ}C$	-	3	6	mA	
Quiescent Current Change	ΔI_{BI}	1	$-25V \leq V_{IN} \leq -8V$ $5mA \leq I_{OUT} \leq 1.0A$	-	0.1	1.3	mA	
	ΔI_{BO}			-	0.05	0.5		
Output Noise Voltage	V_{NO}	2	$T_a = 25^{\circ}C$, $10Hz \leq f \leq 100kHz$	-	100	-	μV_{rms}	
Ripple Rejection Ratio	RR	3	$f = 120Hz$, $I_{OUT} = 20mA$,	54	60	-	dB	
Short Circuit Current Limit	I_{SC}	1	$T_j = 25^{\circ}C$	-	1.9	-	A	
Average Temperature Coefficient of Output Voltage	T_{CVO}	1	$I_{OUT} = 5.0mA$	-	-0.4	-	mV/ $^{\circ}C$	
Dropout Voltage	V_D	1	$T_j = 25^{\circ}C$, $I_{OUT} = 1A$	-	2.0	-	V	

KIA7905P/PI ~ KIA7924P/PI

ELECTRICAL CHARACTERISTICS

KIA7906P/PI

(Unless otherwise specified, $V_{IN} = -11V$, $I_{OUT} = 500mA$, $0^{\circ}C \leq T_j \leq 125^{\circ}C$, $C_{IN} = 2.2\mu F$, $C_{OUT} = 1\mu F$)

CHARACTERISTIC	SYMBOL	TEST CIRCUIT	TEST CONDITION	MIN.	TYP.	MAX.	UNIT	
Output Voltage	V_{OUT}	1	$T_j = 25^{\circ}C$	-6.25	-6.0	-5.75	V	
Input Regulation	Reg line	1	$T_j = 25^{\circ}C$	$-13V \leq V_{IN} \leq -9V$	-	5	60	mV
				$-25V \geq V_{IN} \geq -8V$	-	10	120	
Load Regulation	Reg load	1	$T_j = 25^{\circ}C$	$5mA \leq I_{OUT} \leq 1.5A$	-	10	120	mV
				$250mA \leq I_{OUT} \leq 750mA$	-	3	60	
Output Voltage	V_{OUT}	1	$-21V \leq V_{IN} \leq -9V$ $5mA \leq I_{OUT} \leq 1.0A$	-6.3	-6.0	-5.7	V	
Quiescent Current	I_B	1	$T_j = 25^{\circ}C$	-	3	6	mA	
Quiescent Current Change	Line	1	$-25V \leq V_{IN} \leq -9V$ $5mA \leq I_{OUT} \leq 1.0A$	-	-	1.3	mA	
	Load			-	-	0.5		
Output Noise Voltage	V_{NO}	2	$T_a = 25^{\circ}C$, $10Hz \leq f \leq 100kHz$	-	130	-	μV_{rms}	
Ripple Rejection Ratio	RR	3	$f = 120Hz$, $I_{OUT} = 20mA$,	54	60	-	dB	
Short Circuit Current Limit	I_{SC}	1	$T_j = 25^{\circ}C$	-	1.9	-	A	
Average Temperature Coefficient of Output Voltage	T_{CVO}	1	$I_{OUT} = 5mA$	-	-0.5	-	mV/ $^{\circ}C$	
Dropout Voltage	V_D	1	$T_j = 25^{\circ}C$, $I_{OUT} = 1A$	-	2.0	-	V	

KIA7905P/PI~KIA7924P/PI

ELECTRICAL CHARACTERISTICS

KIA7908P/PI

(Unless otherwise specified, $V_{IN}=-14V$, $I_{OUT}=500mA$, $0^{\circ}C \leq T_j \leq 125^{\circ}C$, $C_{IN}=2.2\mu F$, $C_{OUT}=1\mu F$)

CHARACTERISTIC	SYMBOL	TEST CIRCUIT	TEST CONDITION	MIN.	TYP.	MAX.	UNIT	
Output Voltage	V_{OUT}	1	$T_j=25^{\circ}C$	-8.3	-8.0	-7.7	V	
Input Regulation	Reg line	1	$T_j=25^{\circ}C$	$-17V \leq V_{IN} \leq -11V$	-	5	80	mV
				$-25V \leq V_{IN} \leq -10.5V$	-	10	100	
Load Regulation	Reg load	1	$T_j=25^{\circ}C$	$5mA \leq I_{OUT} \leq 1.5A$	-	12	160	mV
				$250mA \leq I_{OUT} \leq 750mA$	-	4	80	
Output Voltage	V_{OUT}	1	$-23V \leq V_{IN} \leq -11.5V$ $5mA \leq I_{OUT} \leq 1.0A$	-8.4	-8.0	-7.6	V	
Quiescent Current	I_B	1	$T_j=25^{\circ}C$	-	3	6	mA	
Quiescent Current Change	Line	1	$-25V \leq V_{IN} \leq -11.5V$ $5mA \leq I_{OUT} \leq 1.0A$	-	0.1	1.0	mA	
	Load			-	0.05	0.5		
Output Noise Voltage	V_{NO}	2	$T_a=25^{\circ}C$, $10Hz \leq f \leq 100kHz$	-	175	-	μV_{rms}	
Ripple Rejection Ratio	RR	3	$f=120Hz$, $I_{OUT}=20mA$,	54	60	-	dB	
Short Circuit Current Limit	I_{SC}	1	$T_j=25^{\circ}C$	-	1.9	-	A	
Average Temperature Coefficient of Output Voltage	T_{CVO}	1	$I_{OUT}=5mA$	-	-0.6	-	mV/ $^{\circ}C$	
Dropout Voltage	V_D	1	$T_j=25^{\circ}C$, $I_{OUT}=1A$	-	2.0	-	V	

KIA7905P/PI~KIA7924P/PI

ELECTRICAL CHARACTERISTICS

KIA7909P/PI

(Unless otherwise specified, $V_{IN}=-15V$, $I_{OUT}=500mA$, $0^{\circ}C \leq T_j \leq 125^{\circ}C$, $C_{IN}=2.2\mu F$, $C_{OUT}=1\mu F$)

CHARACTERISTIC	SYMBOL	TEST CIRCUIT	TEST CONDITION	MIN.	TYP.	MAX.	UNIT	
Output Voltage	V_{OUT}	1	$T_j=25^{\circ}C$	-9.3	-9.0	-8.7	V	
Input Regulation	Reg line	1	$T_j=25^{\circ}C$	$-19V \leq V_{IN} \leq -13V$	-	5	90	mV
				$-26V \leq V_{IN} \leq -11.5V$	-	10	100	
Load Regulation	Reg load	1	$T_j=25^{\circ}C$	$5mA \leq I_{OUT} \leq 1.5A$	-	10	150	mV
				$250mA \leq I_{OUT} \leq 750mA$	-	5	120	
Output Voltage	V_{OUT}	1	$-24V \leq V_{IN} \leq -11.5V$ $5mA \leq I_{OUT} \leq 1.0A$	-9.4	-9.0	-8.6	V	
Quiescent Current	I_B	1	$T_j=25^{\circ}C$	-	3	6	mA	
Quiescent Current Change	Line	1	$-26.5V \leq V_{IN} \leq -13V$	-	0.1	1.0	mA	
	Load			$5mA \leq I_{OUT} \leq 1.0A$	-	0.05		0.5
Output Noise Voltage	V_{NO}	2	$T_a=25^{\circ}C$, $10Hz \leq f \leq 100kHz$	-	180	-	μV_{rms}	
Ripple Rejection Ratio	RR	3	$f=120Hz$, $I_{OUT}=20mA$,	54	60	-	dB	
Short Circuit Current Limit	I_{SC}	1	$T_j=25^{\circ}C$	-	1.9	-	A	
Average Temperature Coefficient of Output Voltage	T_{CVO}	1	$I_{OUT}=5mA$	-	-0.7	-	mV/ $^{\circ}C$	
Dropout Voltage	V_D	1	$T_j=25^{\circ}C$, $I_{OUT}=1A$	-	2.0	-	V	

KIA7905P/PI ~ KIA7924P/PI

ELECTRICAL CHARACTERISTICS

KIA7910P/PI

(Unless otherwise specified, $V_{IN}=-16V$, $I_{OUT}=500mA$, $0^{\circ}C \leq T_j \leq 125^{\circ}C$, $C_{IN}=2.2\mu F$, $C_{OUT}=1\mu F$)

CHARACTERISTIC		SYMBOL	TEST CIRCUIT	TEST CONDITION	MIN.	TYP.	MAX.	UNIT	
Output Voltage		V_{OUT}	1	$T_j=25^{\circ}C$	-10.4	-10	-9.6	V	
Input Regulation		Reg line	1	$T_j=25^{\circ}C$	$-20V \leq V_{IN} \leq -14V$	-	5	100	mV
					$-27V \leq V_{IN} \leq -12.5V$	-	10	110	
Load Regulation		Reg load	1	$T_j=25^{\circ}C$	$5mA \leq I_{OUT} \leq 1.5A$	-	10	180	mV
					$250mA \leq I_{OUT} \leq 750mA$	-	6	120	
Output Voltage		V_{OUT}	1	$-25V \leq V_{IN} \leq -12.5V$ $5mA \leq I_{OUT} \leq 1.0A$	-10.5	-10	-9.5	V	
Quiescent Current		I_B	1	$T_j=25^{\circ}C$	-	3	6	mA	
Quiescent Current Change		Line	1	$-27.5V \leq V_{IN} \leq -14V$ $5mA \leq I_{OUT} \leq 1.0A$	-	0.1	1.0	mA	
		Load			-	0.05	0.5		
Output Noise Voltage		V_{NO}	2	$T_a=25^{\circ}C$, $10Hz \leq f \leq 100kHz$	-	190	-	μV_{rms}	
Ripple Rejection Ratio		RR	3	$f=120Hz$, $I_{OUT}=20mA$	54	60	-	dB	
Short Circuit Current Limit		I_{SC}	1	$T_j=25^{\circ}C$	-	1.9	-	A	
Average Temperature Coefficient of Output Voltage		T_{CVO}	1	$I_{OUT}=5mA$	-	-0.7	-	mV/ $^{\circ}C$	
Dropout Voltage		V_D	1	$T_j=25^{\circ}C$, $I_{OUT}=1A$	-	2.0	-	V	

KIA7905P/PI ~ KIA7924P/PI

ELECTRICAL CHARACTERISTICS

KIA7912P/PI

(Unless otherwise specified, $V_{IN}=-18V$, $I_{OUT}=500mA$, $0^{\circ}C \leq T_j \leq 125^{\circ}C$, $C_{IN}=2.2\mu F$, $C_{OUT}=1\mu F$)

CHARACTERISTIC		SYMBOL	TEST CIRCUIT	TEST CONDITION	MIN.	TYP.	MAX.	UNIT	
Output Voltage		V_{OUT}	1	$T_j=25^{\circ}C$	-12.5	-12	-11.5	V	
Input Regulation		Reg line	1	$T_j=25^{\circ}C$	$-22V \leq V_{IN} \leq -16V$	-	6	120	mV
					$-30V \leq V_{IN} \leq -14.5V$	-	12	240	
Load Regulation		Reg load	1	$T_j=25^{\circ}C$	$5mA \leq I_{OUT} \leq 1.5A$	-	12	240	mV
					$250mA \leq I_{OUT} \leq 750mA$	-	4	120	
Output Voltage		V_{OUT}	1	$-27V \leq V_{IN} \leq -15.5V$ $5mA \leq I_{OUT} \leq 1.0A$	-12.6	-12	-11.4	V	
Quiescent Current		I_B	1	$T_j=25^{\circ}C$	-	3	6	mA	
Quiescent Current Change		Line	1	$-30V \leq V_{IN} \leq -15V$ $5mA \leq I_{OUT} \leq 1.0A$	-	0.1	1.0	mA	
		Load			-	0.05	0.5		
Output Noise Voltage		V_{NO}	2	$T_a=25^{\circ}C$, $10Hz \leq f \leq 100kHz$	-	200	-	μV_{rms}	
Ripple Rejection Ratio		RR	3	$f=120Hz$, $I_{OUT}=20mA$,	54	60	-	dB	
Short Circuit Current Limit		I_{SC}	1	$T_j=25^{\circ}C$	-	1.9	-	A	
Average Temperature Coefficient of Output Voltage		T_{CVO}	1	$I_{OUT}=5mA$	-	-0.8	-	mV/ $^{\circ}C$	
Dropout Voltage		V_D	1	$T_j=25^{\circ}C$, $I_{OUT}=1A$	-	2.0	-	V	

KIA7905P/PI ~ KIA7924P/PI

ELECTRICAL CHARACTERISTICS

KIA7915P/PI

(Unless otherwise specified, $V_{IN} = -23V$, $I_{OUT} = 500mA$, $0^{\circ}C \leq T_j \leq 125^{\circ}C$, $C_{IN} = 2.2\mu F$, $C_{OUT} = 1\mu F$)

CHARACTERISTIC		SYMBOL	TEST CIRCUIT	TEST CONDITION	MIN.	TYP.	MAX.	UNIT	
Output Voltage		V_{OUT}	1	$T_j = 25^{\circ}C$	-15.6	-15	-14.4	V	
Input Regulation		Reg line	1	$T_j = 25^{\circ}C$	$-26V \leq V_{IN} \leq -20V$	-	6	150	mV
					$-30V \leq V_{IN} \leq -17.5V$	-	12	300	
Load Regulation		Reg load	1	$T_j = 25^{\circ}C$	$5mA \leq I_{OUT} \leq 1.5A$	-	12	300	mV
					$250mA \leq I_{OUT} \leq 750mA$	-	4	150	
Output Voltage		V_{OUT}	1	$-30V \leq V_{IN} \leq -18V$ $5mA \leq I_{OUT} \leq 1.0A$	-15.75	-15	-14.25	V	
Quiescent Current		I_B	1	$T_j = 25^{\circ}C$	-	3	6	mA	
Quiescent Current Change		Line	1	$-30V \leq V_{IN} \leq -17.5V$ $5mA \leq I_{OUT} \leq 1.0A$	-	0.1	1.0	mA	
		Load			-	0.05	0.5		
Output Noise Voltage		V_{NO}	2	$T_a = 25^{\circ}C$, $10Hz \leq f \leq 100kHz$	-	250	-	μV_{rms}	
Ripple Rejection Ratio		RR	3	$f = 120Hz$, $I_{OUT} = 20mA$,	54	60	-	dB	
Short Circuit Current Limit		I_{SC}	1	$T_j = 25^{\circ}C$	-	1.9	-	A	
Average Temperature Coefficient of Output Voltage		T_{CVO}	1	$I_{OUT} = 5mA$	-	-0.9	-	mV/ $^{\circ}C$	
Dropout Voltage		V_D	1	$T_j = 25^{\circ}C$, $I_{OUT} = 1A$	-	2.0	-	V	

KIA7905P/PI ~ KIA7924P/PI

ELECTRICAL CHARACTERISTICS

KIA7918P/PI

(Unless otherwise specified, $V_{IN} = -27V$, $I_{OUT} = 500mA$, $0^{\circ}C \leq T_j \leq 125^{\circ}C$, $C_{IN} = 2.2\mu F$, $C_{OUT} = 1\mu F$)

CHARACTERISTIC	SYMBOL	TEST CIRCUIT	TEST CONDITION	MIN.	TYP.	MAX.	UNIT	
Output Voltage	V_{OUT}	1	$T_j = 25^{\circ}C$	-18.7	-18	-17.3	V	
Input Regulation	Reg line	1	$T_j = 25^{\circ}C$	$-30V \leq V_{IN} \leq -24V$	-	8	180	mV
				$-33V \leq V_{IN} \leq -21V$	-	15	360	
Load Regulation	Reg load	1	$T_j = 25^{\circ}C$	$5mA \leq I_{OUT} \leq 1.5A$	-	15	360	mV
				$250mA \leq I_{OUT} \leq 750mA$	-	5	180	
Output Voltage	V_{OUT}	1	$-33V \leq V_{IN} \leq -22.5V$ $5mA \leq I_{OUT} \leq 1.0A$	-18.85	-18	-17.15	V	
Quiescent Current	I_B	1	$T_j = 25^{\circ}C$	-	3	6	mA	
Quiescent Current Change	Line	1	$-33V \leq V_{IN} \leq -22V$	-	-	1.0	mA	
	Load			$5mA \leq I_{OUT} \leq 1.0A$	-	-		0.5
Output Noise Voltage	V_{NO}	2	$T_a = 25^{\circ}C$, $10Hz \leq f \leq 100kHz$	-	300	-	μV_{rms}	
Ripple Rejection Ratio	RR	3	$f = 120Hz$, $I_{OUT} = 20mA$,	54	60	-	dB	
Short Circuit Current Limit	I_{SC}	1	$T_j = 25^{\circ}C$	-	1.9	-	A	
Average Temperature Coefficient of Output Voltage	T_{CVO}	1	$I_{OUT} = 5mA$	-	-1.0	-	mV/ $^{\circ}C$	
Dropout Voltage	V_D	1	$T_j = 25^{\circ}C$, $I_{OUT} = 1A$	-	2.0	-	V	

KIA7905P/PI ~ KIA7924P/PI

ELECTRICAL CHARACTERISTICS

KIA7920P/PI

(Unless otherwise specified, $V_{IN}=-30V$, $I_{OUT}=500mA$, $0^{\circ}C \leq T_j \leq 125^{\circ}C$, $C_{IN}=2.2\mu F$, $C_{OUT}=1\mu F$)

CHARACTERISTIC		SYMBOL	TEST CIRCUIT	TEST CONDITION	MIN.	TYP.	MAX.	UNIT	
Output Voltage		V_{OUT}	1	$T_j=25^{\circ}C$	-20.8	-20	-19.2	V	
Input Regulation		Reg line	1	$T_j=25^{\circ}C$	$-32V \leq V_{IN} \leq -26V$	-	10	180	mV
					$-35V \leq V_{IN} \leq -24V$	-	18	360	
Load Regulation		Reg load	1	$T_j=25^{\circ}C$	$5mA \leq I_{OUT} \leq 1.5A$	-	18	360	mV
					$250mA \leq I_{OUT} \leq 750mA$	-	10	180	
Output Voltage		V_{OUT}	1	$-35V \leq V_{IN} \leq -24V$ $5mA \leq I_{OUT} \leq 1.0A$	-21.0	-20	-19.0	V	
Quiescent Current		I_B	1	$T_j=25^{\circ}C$	-	3	6	mA	
Quiescent Current Change		Line	1	$-36.5V \leq V_{IN} \leq -25V$ $5mA \leq I_{OUT} \leq 1.0A$	-	-	1.0	mA	
		Load			-	-	0.5		
Output Noise Voltage		V_{NO}	2	$T_a=25^{\circ}C$, $10Hz \leq f \leq 100kHz$	-	350	-	μV_{rms}	
Ripple Rejection Ratio		RR	3	$f=120Hz$, $I_{OUT}=20mA$,	54	60	-	dB	
Short Circuit Current Limit		I_{SC}	1	$T_j=25^{\circ}C$	-	1.9	-	A	
Average Temperature Coefficient of Output Voltage		T_{CVO}	1	$I_{OUT}=5mA$	-	-1.0	-	mV/ $^{\circ}C$	
Dropout Voltage		V_D	1	$T_j=25^{\circ}C$, $I_{OUT}=1A$	-	2.0	-	V	

KIA7905P/PI ~ KIA7924P/PI

ELECTRICAL CHARACTERISTICS

KIA7924P/PI

(Unless otherwise specified, $V_{IN}=-33V$, $I_{OUT}=500mA$, $0^{\circ}C \leq T_j \leq 125^{\circ}C$, $C_{IN}=0.33\mu F$, $C_{OUT}=0.1\mu F$)

CHARACTERISTIC	SYMBOL	TEST CIRCUIT	TEST CONDITION	MIN.	TYP.	MAX.	UNIT	
Output Voltage	V_{OUT}	1	$T_j=25^{\circ}C$	-25	-24	-23	V	
Input Regulation	Reg line	1	$T_j=25^{\circ}C$	$-36V \leq V_{IN} \leq -30V$	-	8	240	mV
				$-38V \leq V_{IN} \leq -27V$	-	15	480	
Load Regulation	Reg load	1	$T_j=25^{\circ}C$	$5mA \leq I_{OUT} \leq 1.5A$	-	15	480	mV
				$250mA \leq I_{OUT} \leq 750mA$	-	5	240	
Output Voltage	V_{OUT}	1	$-38V \leq V_{IN} \leq -27V$ $5mA \leq I_{OUT} \leq 1.0A$	-25.2	-24	-22.5	V	
Quiescent Current	I_B	1	$T_j=25^{\circ}C$	-	3	6	mA	
Quiescent Current Change	Line	1	$-38V \leq V_{IN} \leq -27V$ $5mA \leq I_{OUT} \leq 1.0A$	-	-	1.0	mA	
	Load			-	-	0.5		
Output Noise Voltage	V_{NO}	2	$T_a=25^{\circ}C$, $10Hz \leq f \leq 100kHz$	-	400	-	μV_{rms}	
Ripple Rejection Ratio	RR	3	$f=120Hz$, $I_{OUT}=20mA$,	54	60	-	dB	
Short Circuit Current Limit	I_{SC}	1	$T_j=25^{\circ}C$	-	1.9	-	A	
Average Temperature Coefficient of Output Voltage	T_{CVO}	1	$I_{OUT}=5mA$	-	-1.0	-	mV/ $^{\circ}C$	
Dropout Voltage	V_D	1	$T_a=25^{\circ}C$, $I_{OUT}=1A$	-	2.0	-	V	

KIA7905P/PI ~ KIA7924P/PI

TEST CIRCUIT

1. V_{OUT} , Reg·Line, Reg·Load, I_B , ΔI_B , V_D , T_{cvo}

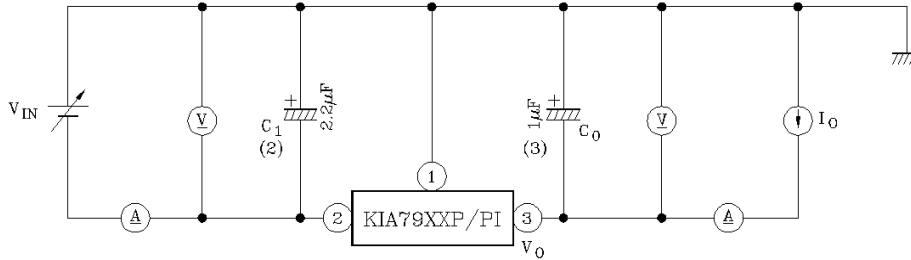

- Notes :
- (1) To specify an output voltage, substitute voltage value for "XX"
 - (2) Required for stability. For value given, capacitor must be solid tantalum. If aluminium electrolytics are used, at least ten times value shown should be selected. C_1 is required if regulator is located an appreciable distance from power supply filter.
 - (3) To improve transient response. If large capacitors are used, a high current diode from input to output (1N4001 or similar) should be introduced to protect the device from momentary input short circuit.

2. V_{NO}

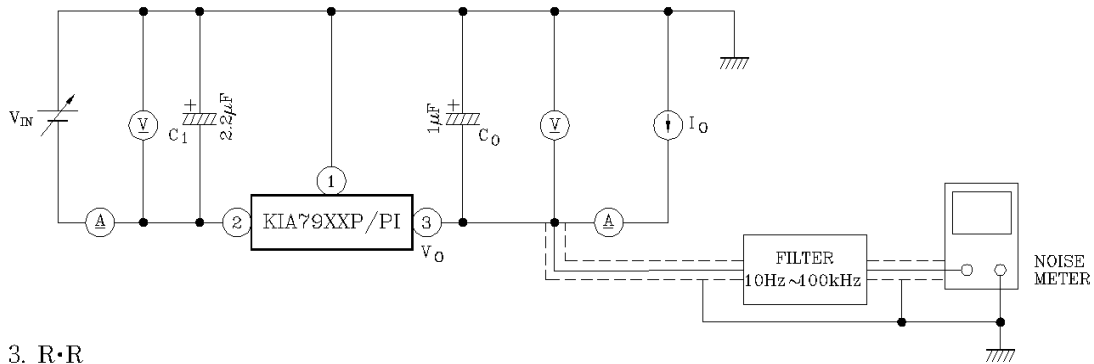

3. R·R

