

1A THREE TERMINAL NEGATIVE VOLTAGE REGULATORS
-5V, -6V, -8V, -9V, -10V, -12V, -15V, -18V, -20V, -24V.

FEATURES

- Suitable for C-MOS, TTL, and the other digital IC power supply.
- Internal thermal overload protecting.
- Internal short circuit current limiting.
- Output current in excess of 1.0A.

MAXIMUM RATINGS (Ta=25 °C)

CHARACTERISTIC		SYMBOL	RATING	UNIT
Input Voltage	KIA7905F ~ KIA7915F	V _{IN}	-35	V
	KIA7918F ~ KIA7924F		-40	
Power Dissipation (Tc=25 °C)		P _D	12	W
Power Dissipation (Without Heatsink)		P _D	1.3	W
Operating Junction Temperature		T _j	-30 ~ 150	°C
Operating Temperature		T _{opr}	-30 ~ 75	°C
Storage Temperature		T _{stg}	-55 ~ 150	°C

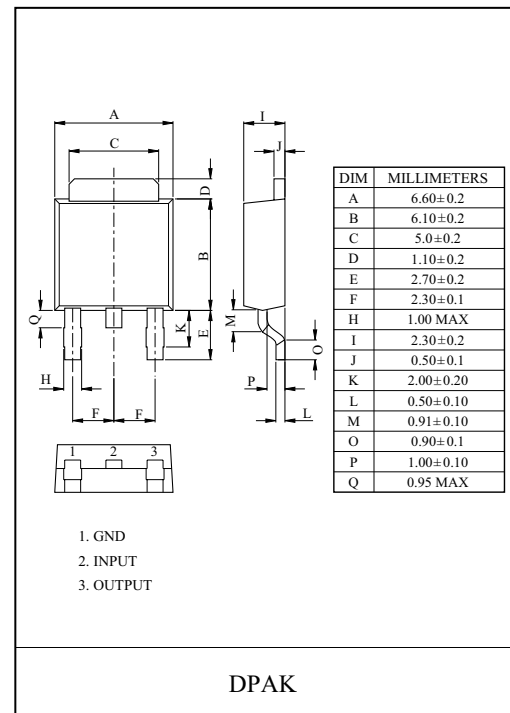

KIA7905F~KIA7924F

EQUIVALENT CIRCUIT

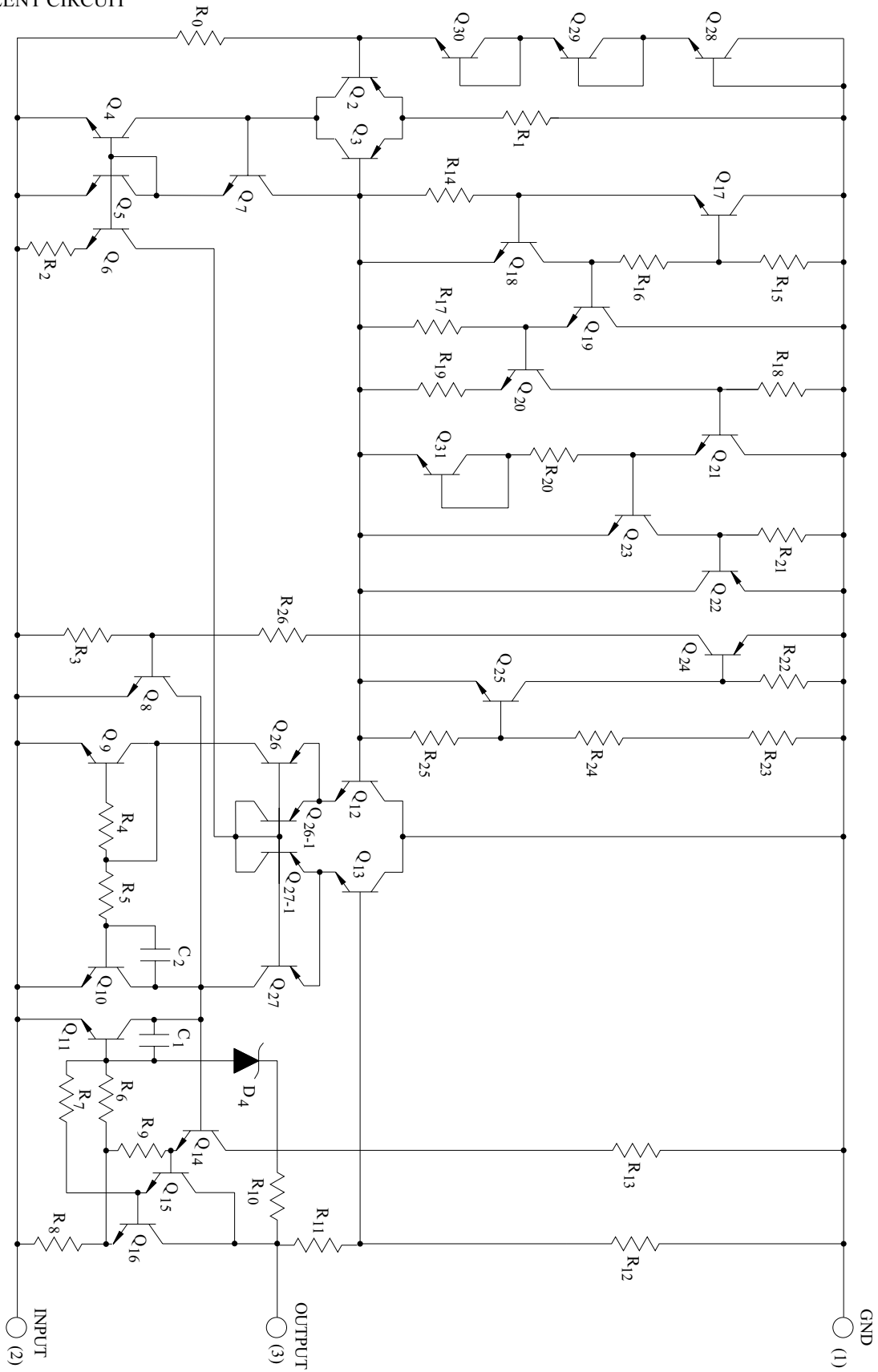

KIA7905F~KIA7924F

ELECTRICAL CHARACTERISTICS

KIA7905F

(Unless otherwise specified, $V_{IN}=-10V$, $I_{OUT}=500mA$, $0\text{ }^{\circ}C \leq T_j \leq 125\text{ }^{\circ}C$, $C_{IN}=2.2\mu F$, $C_{OUT}=1\mu F$)

CHARACTERISTIC	SYMBOL	TEST CIRCUIT	TEST CONDITION	MIN.	TYP.	MAX.	UNIT	
Output Voltage	V_{OUT}	1	$T_j=25\text{ }^{\circ}C$	-5.2	-5.0	-4.8	V	
Input Regulation	Reg line	1	$T_j=25\text{ }^{\circ}C$	$-12V \leq V_{IN} \leq -8V$	-	5	50	mV
				$-25V \leq V_{IN} \leq -7V$	-	10	100	
Load Regulation	Reg load	1	$T_j=25\text{ }^{\circ}C$	$5mA \leq I_{OUT} \leq 1.5A$	-	10	100	mV
				$250mA \leq I_{OUT} \leq 750mA$	-	3	50	
Output Voltage	V_{OUT}	1	$-20V \leq V_{IN} \leq -7V$ $5mA \leq I_{OUT} \leq 1.0A$	-5.25	-5.0	-4.75	V	
Quiescent Current	I_B	1	$T_j=25\text{ }^{\circ}C$	-	3	6	mA	
Quiescent Current Change	ΔI_{BI}	1	$-25V \leq V_{IN} \leq -8V$ $5mA \leq I_{OUT} \leq 1.0A$	-	0.1	1.3	mA	
	ΔI_{BO}			-	0.05	0.5		
Output Noise Voltage	V_{NO}	2	$T_a=25\text{ }^{\circ}C$, $10Hz \leq f \leq 100kHz$	-	100	-	μV_{rms}	
Ripple Rejection Ratio	RR	3	$f=120Hz$, $I_{OUT}=20mA$,	54	60	-	dB	
Short Circuit Current Limit	I_{SC}	1	$T_j=25\text{ }^{\circ}C$	-	1.9	-	A	
Average Temperature Coefficient of Output Voltage	T_{CVO}	1	$I_{OUT}=5.0mA$	-	-0.4	-	mV/ $^{\circ}C$	
Dropout Voltage	V_D	1	$T_j=25\text{ }^{\circ}C$, $I_{OUT}=1A$	-	2.0	-	V	

KIA7905F~KIA7924F

ELECTRICAL CHARACTERISTICS

KIA7906F

(Unless otherwise specified, $V_{IN}=-11V$, $I_{OUT}=500mA$, $0^{\circ}C \leq T_j \leq 125^{\circ}C$, $C_{IN}=2.2\mu F$, $C_{OUT}=1\mu F$)

CHARACTERISTIC		SYMBOL	TEST CIRCUIT	TEST CONDITION	MIN.	TYP.	MAX.	UNIT	
Output Voltage		V_{OUT}	1	$T_j=25^{\circ}C$	-6.25	-6.0	-5.75	V	
Input Regulation		Reg line	1	$T_j=25^{\circ}C$	$-13V \leq V_{IN} \leq -9V$	-	5	60	mV
					$-25V \leq V_{IN} \leq -8V$	-	10	120	
Load Regulation		Reg load	1	$T_j=25^{\circ}C$	$5mA \leq I_{OUT} \leq 1.5A$	-	10	120	mV
					$250mA \leq I_{OUT} \leq 750mA$	-	3	60	
Output Voltage		V_{OUT}	1	$-21V \leq V_{IN} \leq -9V$ $5mA \leq I_{OUT} \leq 1.0A$	-6.3	-6.0	-5.7	V	
Quiescent Current		I_B	1	$T_j=25^{\circ}C$	-	3	6	mA	
Quiescent Current Change		Line	1	$-25V \leq V_{IN} \leq -9V$	-	-	1.3	mA	
		Load							$5mA \leq I_{OUT} \leq 1.0A$
Output Noise Voltage		V_{NO}	2	$T_a=25^{\circ}C$, $10Hz \leq f \leq 100kHz$	-	130	-	μV_{rms}	
Ripple Rejection Ratio		RR	3	$f=120Hz$, $I_{OUT}=20mA$,	54	60	-	dB	
Short Circuit Current Limit		I_{SC}	1	$T_j=25^{\circ}C$	-	1.9	-	A	
Average Temperature Coefficient of Output Voltage		T_{CVO}	1	$I_{OUT}=5mA$	-	-0.5	-	mV/ $^{\circ}C$	
Dropout Voltage		V_D	1	$T_j=25^{\circ}C$, $I_{OUT}=1A$	-	2.0	-	V	

KIA7905F~KIA7924F

ELECTRICAL CHARACTERISTICS

KIA7908F

(Unless otherwise specified, $V_{IN}=-14V$, $I_{OUT}=500mA$, $0\text{ }^{\circ}C \leq T_j \leq 125\text{ }^{\circ}C$, $C_{IN}=2.2\mu F$, $C_{OUT}=1\mu F$)

CHARACTERISTIC		SYMBOL	TEST CIRCUIT	TEST CONDITION	MIN.	TYP.	MAX.	UNIT	
Output Voltage		V_{OUT}	1	$T_j=25\text{ }^{\circ}C$	-8.3	-8.0	-7.7	V	
Input Regulation		Reg line	1	$T_j=25\text{ }^{\circ}C$	$-17V \leq V_{IN} \leq -11V$	-	5	80	mV
					$-25V \leq V_{IN} \leq -10.5V$	-	10	100	
Load Regulation		Reg load	1	$T_j=25\text{ }^{\circ}C$	$5mA \leq I_{OUT} \leq 1.5A$	-	12	160	mV
					$250mA \leq I_{OUT} \leq 750mA$	-	4	80	
Output Voltage		V_{OUT}	1	$-23V \leq V_{IN} \leq -11.5V$ $5mA \leq I_{OUT} \leq 1.0A$	-8.4	-8.0	-7.6	V	
Quiescent Current		I_B	1	$T_j=25\text{ }^{\circ}C$	-	3	6	mA	
Quiescent Current Change		Line	1	$-25V \leq V_{IN} \leq -11.5V$	-	0.1	1.0	mA	
		Load							$5mA \leq I_{OUT} \leq 1.0A$
Output Noise Voltage		V_{NO}	2	$T_a=25\text{ }^{\circ}C$, $10Hz \leq f \leq 100kHz$	-	175	-	μV_{rms}	
Ripple Rejection Ratio		RR	3	$f=120Hz$, $I_{OUT}=20mA$,	54	60	-	dB	
Short Circuit Current Limit		I_{SC}	1	$T_j=25\text{ }^{\circ}C$	-	1.9	-	A	
Average Temperature Coefficient of Output Voltage		T_{CVO}	1	$I_{OUT}=5mA$	-	-0.6	-	mV/ $^{\circ}C$	
Dropout Voltage		V_D	1	$T_j=25\text{ }^{\circ}C$, $I_{OUT}=1A$	-	2.0	-	V	

KIA7905F~KIA7924F

ELECTRICAL CHARACTERISTICS

KIA7909F

(Unless otherwise specified, $V_{IN}=-15V$, $I_{OUT}=500mA$, $0^{\circ}C \leq T_j \leq 125^{\circ}C$, $C_{IN}=2.2\mu F$, $C_{OUT}=1\mu F$)

CHARACTERISTIC	SYMBOL	TEST CIRCUIT	TEST CONDITION	MIN.	TYP.	MAX.	UNIT	
Output Voltage	V_{OUT}	1	$T_j=25^{\circ}C$	-9.3	-9.0	-8.7	V	
Input Regulation	Reg line	1	$T_j=25^{\circ}C$	$-19V \leq V_{IN} \leq -13V$	-	5	90	mV
				$-26V \leq V_{IN} \leq -11.5V$	-	10	100	
Load Regulation	Reg load	1	$T_j=25^{\circ}C$	$5mA \leq I_{OUT} \leq 1.5A$	-	10	150	mV
				$250mA \leq I_{OUT} \leq 750mA$	-	5	120	
Output Voltage	V_{OUT}	1	$-24V \leq V_{IN} \leq -11.5V$ $5mA \leq I_{OUT} \leq 1.0A$	-9.4	-9.0	-8.6	V	
Quiescent Current	I_B	1	$T_j=25^{\circ}C$	-	3	6	mA	
Quiescent Current Change	Line	1	$-26.5V \leq V_{IN} \leq -13V$	-	0.1	1.0	mA	
	Load			$5mA \leq I_{OUT} \leq 1.0A$	-	0.05		0.5
Output Noise Voltage	V_{NO}	2	$T_a=25^{\circ}C$, $10Hz \leq f \leq 100kHz$	-	180	-	μV_{rms}	
Ripple Rejection Ratio	RR	3	$f=120Hz$, $I_{OUT}=20mA$,	54	60	-	dB	
Short Circuit Current Limit	I_{SC}	1	$T_j=25^{\circ}C$	-	1.9	-	A	
Average Temperature Coefficient of Output Voltage	T_{CVO}	1	$I_{OUT}=5mA$	-	-0.7	-	mV/ $^{\circ}C$	
Dropout Voltage	V_D	1	$T_j=25^{\circ}C$, $I_{OUT}=1A$	-	2.0	-	V	

KIA7905F~KIA7924F

ELECTRICAL CHARACTERISTICS

KIA7910F

(Unless otherwise specified, $V_{IN}=-16V$, $I_{OUT}=500mA$, $0^{\circ}C \leq T_j \leq 125^{\circ}C$, $C_{IN}=2.2\mu F$, $C_{OUT}=1\mu F$)

CHARACTERISTIC	SYMBOL	TEST CIRCUIT	TEST CONDITION	MIN.	TYP.	MAX.	UNIT	
Output Voltage	V_{OUT}	1	$T_j=25^{\circ}C$	-10.4	-10	-9.6	V	
Input Regulation	Reg line	1	$T_j=25^{\circ}C$	$-20V \leq V_{IN} \leq -14V$	-	5	100	mV
				$-27V \leq V_{IN} \leq -12.5V$	-	10	110	
Load Regulation	Reg load	1	$T_j=25^{\circ}C$	$5mA \leq I_{OUT} \leq 1.5A$	-	10	180	mV
				$250mA \leq I_{OUT} \leq 750mA$	-	6	120	
Output Voltage	V_{OUT}	1	$-25V \leq V_{IN} \leq -12.5V$ $5mA \leq I_{OUT} \leq 1.0A$	-10.5	-10	-9.5	V	
Quiescent Current	I_B	1	$T_j=25^{\circ}C$	-	3	6	mA	
Quiescent Current Change	Line	1	$-27.5V \leq V_{IN} \leq -14V$	-	0.1	1.0	mA	
	Load							$5mA \leq I_{OUT} \leq 1.0A$
Output Noise Voltage	V_{NO}	2	$T_a=25^{\circ}C$, $10Hz \leq f \leq 100kHz$	-	190	-	μV_{rms}	
Ripple Rejection Ratio	RR	3	$f=120Hz$, $I_{OUT}=20mA$	54	60	-	dB	
Short Circuit Current Limit	I_{SC}	1	$T_j=25^{\circ}C$	-	1.9	-	A	
Average Temperature Coefficient of Output Voltage	T_{CVO}	1	$I_{OUT}=5mA$	-	-0.7	-	mV/ $^{\circ}C$	
Dropout Voltage	V_D	1	$T_j=25^{\circ}C$, $I_{OUT}=1A$	-	2.0	-	V	

KIA7905F~KIA7924F

ELECTRICAL CHARACTERISTICS

KIA7912F

(Unless otherwise specified, $V_{IN}=-18V$, $I_{OUT}=500mA$, $0^{\circ}C \leq T_j \leq 125^{\circ}C$, $C_{IN}=2.2\mu F$, $C_{OUT}=1\mu F$)

CHARACTERISTIC		SYMBOL	TEST CIRCUIT	TEST CONDITION	MIN.	TYP.	MAX.	UNIT	
Output Voltage		V_{OUT}	1	$T_j=25^{\circ}C$	-12.5	-12	-11.5	V	
Input Regulation		Reg line	1	$T_j=25^{\circ}C$	$-22V \leq V_{IN} \leq -16V$	-	6	120	mV
					$-30V \leq V_{IN} \leq -14.5V$	-	12	240	
Load Regulation		Reg load	1	$T_j=25^{\circ}C$	$5mA \leq I_{OUT} \leq 1.5A$	-	12	240	mV
					$250mA \leq I_{OUT} \leq 750mA$	-	4	120	
Output Voltage		V_{OUT}	1	$-27V \leq V_{IN} \leq -15.5V$ $5mA \leq I_{OUT} \leq 1.0A$	-12.6	-12	-11.4	V	
Quiescent Current		I_B	1	$T_j=25^{\circ}C$	-	3	6	mA	
Quiescent Current Change		Line	1	$-30V \leq V_{IN} \leq -15V$	-	0.1	1.0	mA	
		Load							$5mA \leq I_{OUT} \leq 1.0A$
Output Noise Voltage		V_{NO}	2	$T_a=25^{\circ}C$, $10Hz \leq f \leq 100kHz$	-	200	-	μV_{rms}	
Ripple Rejection Ratio		RR	3	$f=120Hz$, $I_{OUT}=20mA$,	54	60	-	dB	
Short Circuit Current Limit		I_{SC}	1	$T_j=25^{\circ}C$	-	1.9	-	A	
Average Temperature Coefficient of Output Voltage		T_{CVO}	1	$I_{OUT}=5mA$	-	-0.8	-	mV/ $^{\circ}C$	
Dropout Voltage		V_D	1	$T_j=25^{\circ}C$, $I_{OUT}=1A$	-	2.0	-	V	

KIA7905F~KIA7924F

ELECTRICAL CHARACTERISTICS

KIA7915F

(Unless otherwise specified, $V_{IN}=-23V$, $I_{OUT}=500mA$, $0\text{ }^{\circ}C \leq T_j \leq 125\text{ }^{\circ}C$, $C_{IN}=2.2\mu F$, $C_{OUT}=1\mu F$)

CHARACTERISTIC		SYMBOL	TEST CIRCUIT	TEST CONDITION	MIN.	TYP.	MAX.	UNIT	
Output Voltage		V_{OUT}	1	$T_j=25\text{ }^{\circ}C$	-15.6	-15	-14.4	V	
Input Regulation		Reg line	1	$T_j=25\text{ }^{\circ}C$	$-26V \leq V_{IN} \leq -20V$	-	6	150	mV
					$-30V \leq V_{IN} \leq -17.5V$	-	12	300	
Load Regulation		Reg load	1	$T_j=25\text{ }^{\circ}C$	$5mA \leq I_{OUT} \leq 1.5A$	-	12	300	mV
					$250mA \leq I_{OUT} \leq 750mA$	-	4	150	
Output Voltage		V_{OUT}	1	$-30V \leq V_{IN} \leq -18V$ $5mA \leq I_{OUT} \leq 1.0A$	-15.75	-15	-14.25	V	
Quiescent Current		I_B	1	$T_j=25\text{ }^{\circ}C$	-	3	6	mA	
Quiescent Current Change		Line	1	$-30V \leq V_{IN} \leq -17.5V$	-	0.1	1.0	mA	
		Load			$5mA \leq I_{OUT} \leq 1.0A$	-	0.05		0.5
Output Noise Voltage		V_{NO}	2	$T_a=25\text{ }^{\circ}C$, $10Hz \leq f \leq 100kHz$	-	250	-	μV_{rms}	
Ripple Rejection Ratio		RR	3	$f=120Hz$, $I_{OUT}=20mA$,	54	60	-	dB	
Short Circuit Current Limit		I_{SC}	1	$T_j=25\text{ }^{\circ}C$	-	1.9	-	A	
Average Temperature Coefficient of Output Voltage		T_{CVO}	1	$I_{OUT}=5mA$	-	-0.9	-	mV/ $^{\circ}C$	
Dropout Voltage		V_D	1	$T_j=25\text{ }^{\circ}C$, $I_{OUT}=1A$	-	2.0	-	V	

KIA7905F~KIA7924F

ELECTRICAL CHARACTERISTICS

KIA7918F

(Unless otherwise specified, $V_{IN}=-27V$, $I_{OUT}=500mA$, $0^{\circ}C \leq T_j \leq 125^{\circ}C$, $C_{IN}=2.2\mu F$, $C_{OUT}=1\mu F$)

CHARACTERISTIC		SYMBOL	TEST CIRCUIT	TEST CONDITION	MIN.	TYP.	MAX.	UNIT	
Output Voltage		V_{OUT}	1	$T_j=25^{\circ}C$	-18.7	-18	-17.3	V	
Input Regulation		Reg line	1	$T_j=25^{\circ}C$	$-30V \leq V_{IN} \leq -24V$	-	8	180	mV
					$-33V \leq V_{IN} \leq -21V$	-	15	360	
Load Regulation		Reg load	1	$T_j=25^{\circ}C$	$5mA \leq I_{OUT} \leq 1.5A$	-	15	360	mV
					$250mA \leq I_{OUT} \leq 750mA$	-	5	180	
Output Voltage		V_{OUT}	1	$-33V \leq V_{IN} \leq -22.5V$ $5mA \leq I_{OUT} \leq 1.0A$	-18.85	-18	-17.15	V	
Quiescent Current		I_B	1	$T_j=25^{\circ}C$	-	3	6	mA	
Quiescent Current Change		Line	1	$-33V \leq V_{IN} \leq -22V$ $5mA \leq I_{OUT} \leq 1.0A$	-	-	1.0	mA	
		Load			-	-	0.5		
Output Noise Voltage		V_{NO}	2	$T_a=25^{\circ}C$, $10Hz \leq f \leq 100kHz$	-	300	-	μV_{rms}	
Ripple Rejection Ratio		RR	3	$f=120Hz$, $I_{OUT}=20mA$,	54	60	-	dB	
Short Circuit Current Limit		I_{SC}	1	$T_j=25^{\circ}C$	-	1.9	-	A	
Average Temperature Coefficient of Output Voltage		T_{CVO}	1	$I_{OUT}=5mA$	-	-1.0	-	mV/ $^{\circ}C$	
Dropout Voltage		V_D	1	$T_j=25^{\circ}C$, $I_{OUT}=1A$	-	2.0	-	V	

KIA7905F~KIA7924F

ELECTRICAL CHARACTERISTICS

KIA7920F

(Unless otherwise specified, $V_{IN}=-30V$, $I_{OUT}=500mA$, $0\text{ }^{\circ}C \leq T_j \leq 125\text{ }^{\circ}C$, $C_{IN}=2.2\mu F$, $C_{OUT}=1\mu F$)

CHARACTERISTIC		SYMBOL	TEST CIRCUIT	TEST CONDITION	MIN.	TYP.	MAX.	UNIT	
Output Voltage		V_{OUT}	1	$T_j=25\text{ }^{\circ}C$	-20.8	-20	-19.2	V	
Input Regulation		Reg line	1	$T_j=25\text{ }^{\circ}C$	$-32V \leq V_{IN} \leq -26V$	-	10	180	mV
					$-35V \leq V_{IN} \leq -24V$	-	18	360	
Load Regulation		Reg load	1	$T_j=25\text{ }^{\circ}C$	$5mA \leq I_{OUT} \leq 1.5A$	-	18	360	mV
					$250mA \leq I_{OUT} \leq 750mA$	-	10	180	
Output Voltage		V_{OUT}	1	$-35V \leq V_{IN} \leq -24V$ $5mA \leq I_{OUT} \leq 1.0A$	-21.0	-20	-19.0	V	
Quiescent Current		I_B	1	$T_j=25\text{ }^{\circ}C$	-	3	6	mA	
Quiescent Current Change		Line	1	$-36.5V \leq V_{IN} \leq -25V$	-	-	1.0	mA	
		Load							$5mA \leq I_{OUT} \leq 1.0A$
Output Noise Voltage		V_{NO}	2	$T_a=25\text{ }^{\circ}C$, $10Hz \leq f \leq 100kHz$	-	350	-	μV_{rms}	
Ripple Rejection Ratio		RR	3	$f=120Hz$, $I_{OUT}=20mA$	54	60	-	dB	
Short Circuit Current Limit		I_{SC}	1	$T_j=25\text{ }^{\circ}C$	-	1.9	-	A	
Average Temperature Coefficient of Output Voltage		T_{CVO}	1	$I_{OUT}=5mA$	-	-1.0	-	mV/ $^{\circ}C$	
Dropout Voltage		V_D	1	$T_j=25\text{ }^{\circ}C$, $I_{OUT}=1A$	-	2.0	-	V	

KIA7905F~KIA7924F

ELECTRICAL CHARACTERISTICS

KIA7924F

(Unless otherwise specified, $V_{IN}=-33V$, $I_{OUT}=500mA$, $0^{\circ}C \leq T_j \leq 125^{\circ}C$, $C_{IN}=0.33\mu F$, $C_{OUT}=0.1\mu F$)

CHARACTERISTIC	SYMBOL	TEST CIRCUIT	TEST CONDITION	MIN.	TYP.	MAX.	UNIT	
Output Voltage	V_{OUT}	1	$T_j=25^{\circ}C$	-25	-24	-23	V	
Input Regulation	Reg line	1	$T_j=25^{\circ}C$	$-36V \leq V_{IN} \leq -30V$	-	8	240	mV
				$-38V \leq V_{IN} \leq -27V$	-	15	480	
Load Regulation	Reg load	1	$T_j=25^{\circ}C$	$5mA \leq I_{OUT} \leq 1.5A$	-	15	480	mV
				$250mA \leq I_{OUT} \leq 750mA$	-	5	240	
Output Voltage	V_{OUT}	1	$-38V \leq V_{IN} \leq -27V$ $5mA \leq I_{OUT} \leq 1.0A$	-25.2	-24	-22.5	V	
Quiescent Current	I_B	1	$T_j=25^{\circ}C$	-	3	6	mA	
Quiescent Current Change	Line	1	$-38V \leq V_{IN} \leq -27V$	-	-	1.0	mA	
	Load			$5mA \leq I_{OUT} \leq 1.0A$	-	-		0.5
Output Noise Voltage	V_{NO}	2	$T_a=25^{\circ}C$, $10Hz \leq f \leq 100kHz$	-	400	-	μV_{rms}	
Ripple Rejection Ratio	RR	3	$f=120Hz$, $I_{OUT}=20mA$,	54	60	-	dB	
Short Circuit Current Limit	I_{SC}	1	$T_j=25^{\circ}C$	-	1.9	-	A	
Average Temperature Coefficient of Output Voltage	T_{CVO}	1	$I_{OUT}=5mA$	-	-1.0	-	mV/ $^{\circ}C$	
Dropout Voltage	V_D	1	$T_a=25^{\circ}C$, $I_{OUT}=1A$	-	2.0	-	V	

KIA7905F~KIA7924F

TEST CIRCUIT

V_{OUT} , Reg · Line, Reg · Load, I_B , ΔI_B , V_D , T_{CVO}

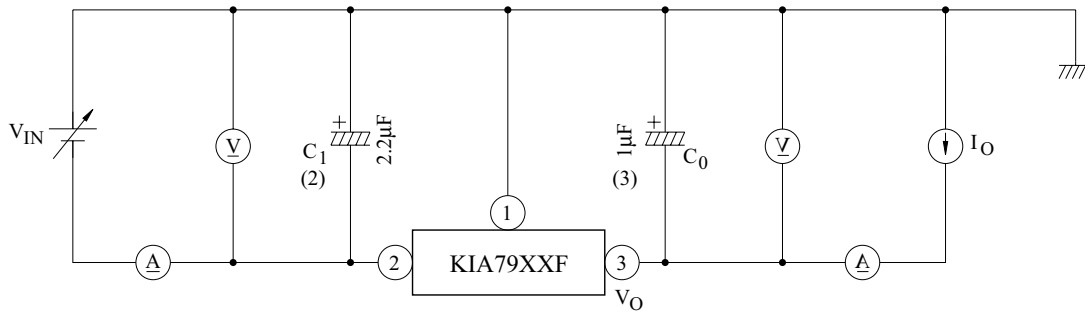

Notes : (1) To specify an output voltage, substitute voltage value for "XX"

(2) Required for stability. For value given, capacitor must be solid tantalum. If aluminium electrolytics are used, at least ten times value shown should be selected. C_1 is required if regulator is located an appreciable distance from power supply filter.

(3) To improve transient response. If large capacitors are used, a high current diode from input to output (1N4001 or similar) should be introduced to protect the device from momentary input short circuit.

2. V_{NO}

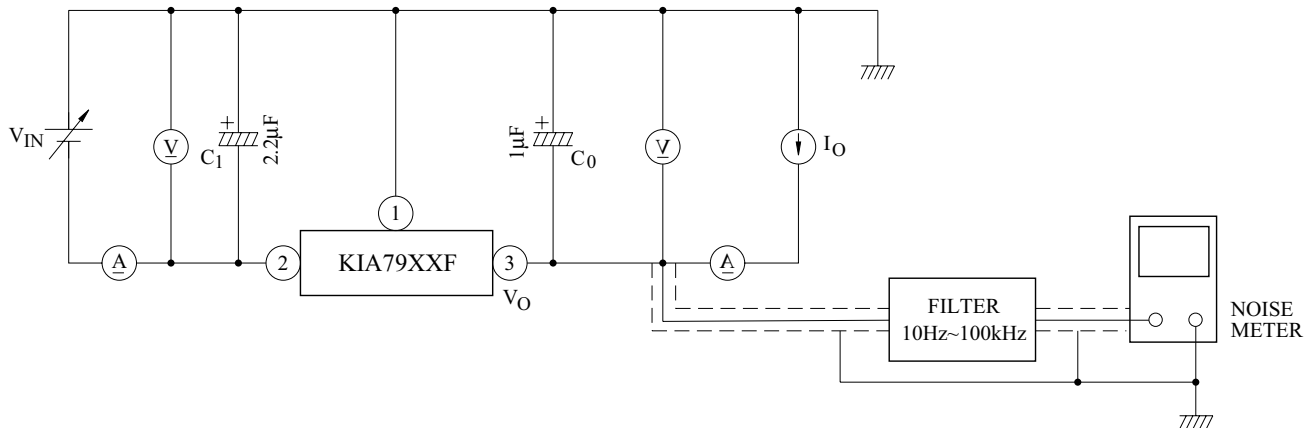

3. R · R

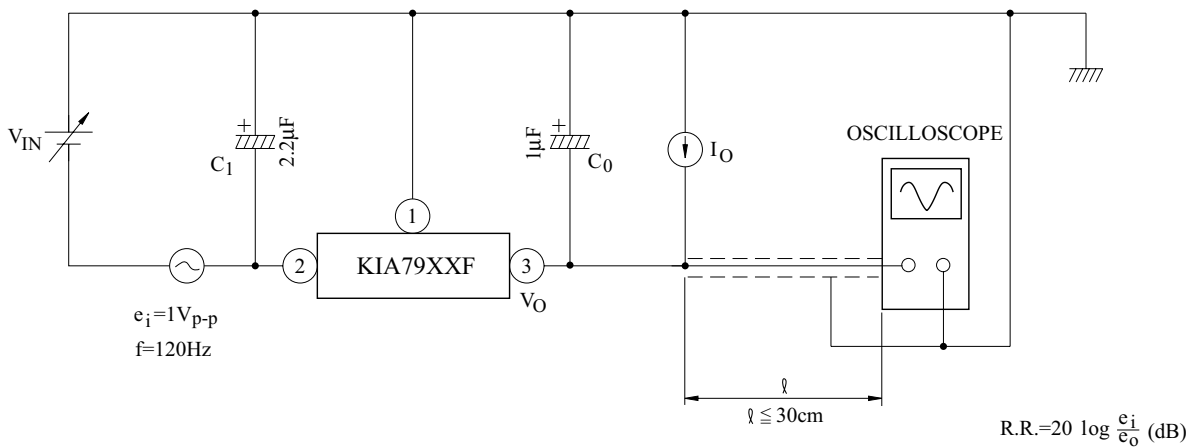

KIA7905F~KIA7924F

