

AsahiKASEI
ASAHI KASEI EMD

AK4185

Low Power Touch Screen Controller with SPI™ Interface

GENERAL DESCRIPTION

The AK4185 is a 4-wire/ 5-wire resistive touch screen controller that incorporates 12bit SAR A/D converter. The AK4185 operates down to 1.6V supply voltage in order to connect a low voltage microprocessor. The AK4185 can detect the pressed screen location by performing two A/D conversions and it can also measure touch pressure. The AK4185 is the best fit for cellular phone, DSC, DVC, smart phone, or other portable devices.

FEATURES

- 4-wire or 5-wire Touch Screen Interface
- SPI™ Serial Interface
- 12bit SAR A/D Converter with S/H circuit
- Sampling Frequency: 300Ksps
- Pen Pressure Measurement (4-wire)
- Continuous Read Function (External Clock Mode)
- Integrated Internal Osc (Sequence Mode)
- Low Voltage Operation: VDD = 1.6V ~ 3.6V
- PENIRQN Buffer Output
- Low Power Consumption: 240μA at 1.8V
- Auto Power Down
- Package: 12pin CSP (1.96mm x 1.46mm, pitch 0.5mm)
- Software Compatible with AK4182A

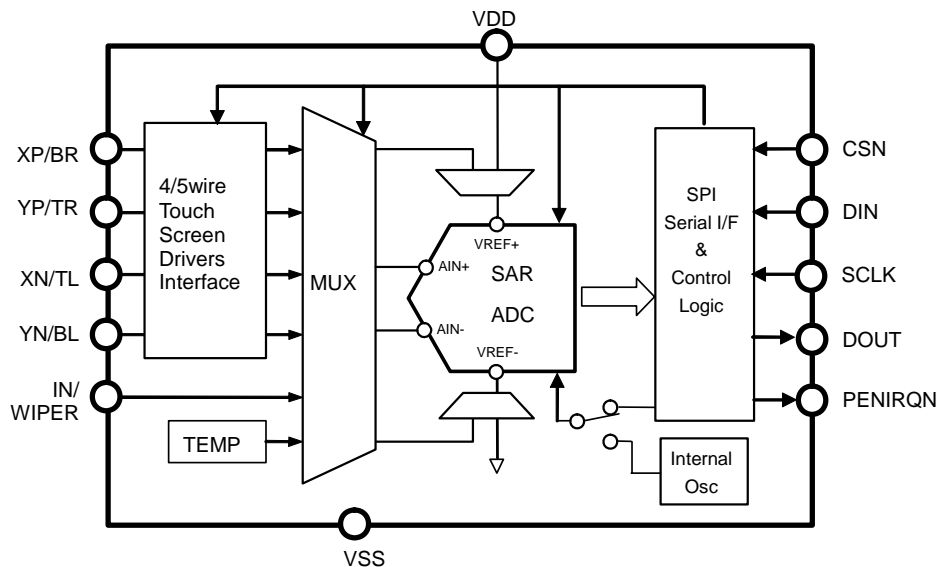

Figure 1. Block Diagram

SPI™ is a registered trademark of Motorola, Inc.

■ Ordering Guide

AK4185ECB -40 ~ +85°C 12pin CSP (1.96mm x 1.46mm, 0.5mm pitch)
 AKD4185 AK4185 Evaluation Board

Black Type

■ Pin Layout

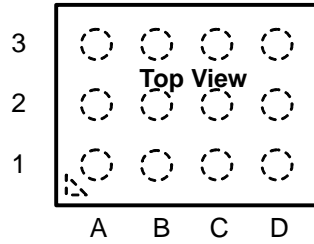

3	XP/BR	YP/TR	XN/TL	YN/BL
2	VDD	CSN	DIN	VSS
1	IN/WIPER	PENIRQN	DOUT	SCLK
	A	B	C	D

TOP View

PIN/FUNCTION			
No.	Pin Name	I/O	Function
C2	DIN	I	Serial Data Input Data is clocked on the rising edge of SCLK. Must keep “L” while not issuing command.
B2	CSN	I	Chip Select Input Enables writing data to registers when CSN = “L”.
D1	SCLK	I	Serial Clock Input
A2	VDD	-	Power Supply and External Reference Input: 1.6V ~ 3.6V
A3	XP	I/O	Touch Panel X+ Input (4-wire, PANEL bit = “0”)
	BR	I/O	Touch Panel Bottom Right Input (5-wire, PANEL bit = “1”)
B3	YP	I/O	Touch Panel Y+ Input (4-wire, PANEL bit = “0”)
	TR	I/O	Touch Panel Top Right Input (5-wire, PANEL bit = “1”)
C3	XN	I/O	Touch Panel X- Input (4-wire, PANEL bit = “0”)
	TL	I/O	Touch Panel Top Left Input (5-wire, PANEL bit = “1”)
D3	YN	I/O	Touch Panel Y- Input (4-wire, PANEL bit = “0”)
	BL	I/O	Touch Panel Bottom Right Input (5-wire, PANEL bit = “1”)
D2	VSS	-	Ground
A1	IN	I	Auxiliary Analog Input (4-wire, PANEL bit = “0”)
	WIPER	I	Top Touch Panel Input (5-wire, PANEL bit = “1”)
B1	PENIRQN	O	Pen Interrupt Output (CMOS output) The PENIRQN pin is “L” when touch-screen press is detected and CSN = “H”. This pin is always “H” irrespective of touch-screen press when pen interrupt is not enabled.
C1	DOUT	O	Serial A/D Data Output Data is clocked at SCLK falling edge. This pin is Hi-Z when CSN keeps “H”.

Note 1. All digital input pins (DIN, CSN, SCLK) must not be left floating.

■ Handling of Unused Pin

The unused I/O pin must be processed appropriately as below.

Classification	Pin Name	Setting
Analog	IN/WIPER	This pin must be open.

ABSOLUTE MAXIMUM RATINGS

(VSS = 0V (Note 2))

Parameter	Symbol	min	max	Units
Power Supply	VDD	-0.3	4.6	V
Input Current, Any Pins except for supply	IIN	-	±10	mA
Touch Panel Drive Current	IOUTDRV	-	50	mA
Input Voltage (Note 3)	VIN	-0.3	VDD+0.3 or 4.6	V
Ambient Temperature (power applied)	Ta	-40	85	°C
Storage Temperature	Tstg	-65	150	°C

Note 2. All voltages with respect to ground.

Note 3. XP/BR, XN/TL, YP/TR, YN/TL, IN/WIPER, CSN, DIN and SCLK pins. The maximum value is smaller value between (VDD+0.3)V and 4.6V.

WARNING: Operation at or beyond these limits may result in permanent damage to the device.
Normal operation is not guaranteed at these extremes.

RECOMMEND OPERATING CONDITIONS

(VSS = 0V (Note 2))

Parameter	Symbol	min	typ	max	Units
Power Supply	VDD	1.6	1.8	3.6	V

Note 2. All voltages with respect to ground.

WARNING: AKEMD assumes no responsibility for the usage beyond the conditions in this datasheet.

ANALOG CHARACTERISTICS

(Ta = -40°C to 85°C, VDD = 1.8V, fSCLK = fs x 16=5.0MHz, 12bit mode)

Parameter	min	typ	max	Units	
A/D Converter					
Resolution	-	12		Bits	
No Missing Codes	11	12		Bits	
Integral Nonlinearity (INL) Error	-	-	±2	LSB	
Differential Nonlinearity (DNL) Error	-2	±1	+3	LSB	
Offset Error	-	-	±6	LSB	
Gain Error	-	-	±4	LSB	
Touch Panel Drivers Switch On-Resistance					
XP, YP	-	5	-	Ω	
XN, YN	-	5	-	Ω	
PENIRQ Pull Up Resistor R _{IRQ}	-	50	-	kΩ	
Auxiliary IN Input					
Input Voltage Range	0		VDD	V	
Temperature Measurement					
Temperature Range	-40		85	°C	
Resolution (Note 4)	-	1.2	-	°C	
Accuracy (Note 5)	-	±3	-	°C	
Power Supply Current					
Normal Mode (Internal Oscillator mode) (Note 6)	VDD=1.8V	-	240	-	μA
	VDD=3.6V	-	-	550	μA
Normal Mode (Bus clock mode) PD0 = "0" (Note 7)	VDD=1.8V	-	340	-	μA
	VDD=3.6V	-	-	800	μA
Full Power Down (when writing control command with PD0 = "0")	-	0	3	μA	

Note 4. "Ideal" value derived from a theory when VDD = 1.8V. This value according to the supplied VDD voltage is 0.6466 x VDD.

Note 5. The typical value has +6°C(typ) offset.

Note 6. The signal of 1kHz, 1.6Vpp (-1dB) is input to the IN/WIPER pin, when COUNT bit = "0", INTERVAL = 0μs and command cycle is 50μs. DOUT C_L = 0pF, the current of touch panel drivers is excluded.

Note 7. The signal of 1kHz, 1.6Vpp (-1dB) is input to the IN/WIPER pin, when Single Mode for external clock (CONTINUE bit = "0") and 15 SCLK clock cycles. DOUT C_L = 0pF, the current of touch panel drivers is excluded.

DC CHARACTERISTICS (Logic I/O)

(Ta=-40°C to 85°C, VDD =1.6V to 3.6V)

Parameter	Symbol	min	typ	max	Units
Digital Input (CSN, SCLK, DIN)					
"H" level input voltage	VIH	0.8xVDD	-	-	V
"L" level input voltage	VIL	-	-	0.2xVDD	V
Input Leakage Current.	IILK	-10		10	μA
Digital Output (DOUT, PENIRQN)					
"H" level output voltage (@ Iout = -250μA)	VOH	VDD-0.4	-	-	V
"L" level output voltage (@ Iout = 250μA)	VOL	-	-	0.4	V
Tri-state Leakage Current	IOLK				
All pins except for XP, YP, XN, YN pins		-10	-	10	μA
XP, YP, XN, YN pins		-10	-	10	μA

SWITCHING CHARACTERISTICS					
(Ta=-40°C to 85°C, VDD=1.6V to 3.6V, CL=50pF)					
Parameter	Symbol	min	typ	max	Units
Internal OSCILLATOR					
Clock Frequency	f_{osc}	2.5	3.6	5.1	MHz
Touch Panel (A/D Converter)					
Throughput Rate	f_s	-	300	-	kHz
SCLK					
frequency	f_{SCLK}	30	-	5000	KHz
duty	duty	40	50	60	%
Sampling Time (Rin = 600Ω) (Note 8)	t_{TRK}	0.6	-	-	μs
Conversion Time	t_{CONV}	-	-	12	1/fSCLK
CSN edge to First SCLK “↑”	t_{CSS}	50	-	-	ns
CSN edge to DOUT Tri-State Disabled	t_{DCD}	-	-	50	ns
SCLK High Pulse Width	t_{CKH}	80	-	-	ns
SCLK Low Pulse Width	t_{CKL}	80	-	-	ns
Data Setup Time	t_{DS}	40	-	-	ns
Data Valid to SCLK Hold Time	t_{DH}	40	-	-	ns
Data Output Delay after SCLK “↓”	t_{DOD}	-	-	70	ns
CSN “↑” to SCLK Ignored	t_{CSI}	50	-	-	ns
CSN “↑” to DOUT Hi-Z state	t_{CCZ}	-	-	90	ns
CSN Hold Time	t_{CSW}	150	-	-	ns

Note 8. The actual tracking periods are $3t_{SCLK}$. ($t_{SCLK} = 1/f_{SCLK}$)

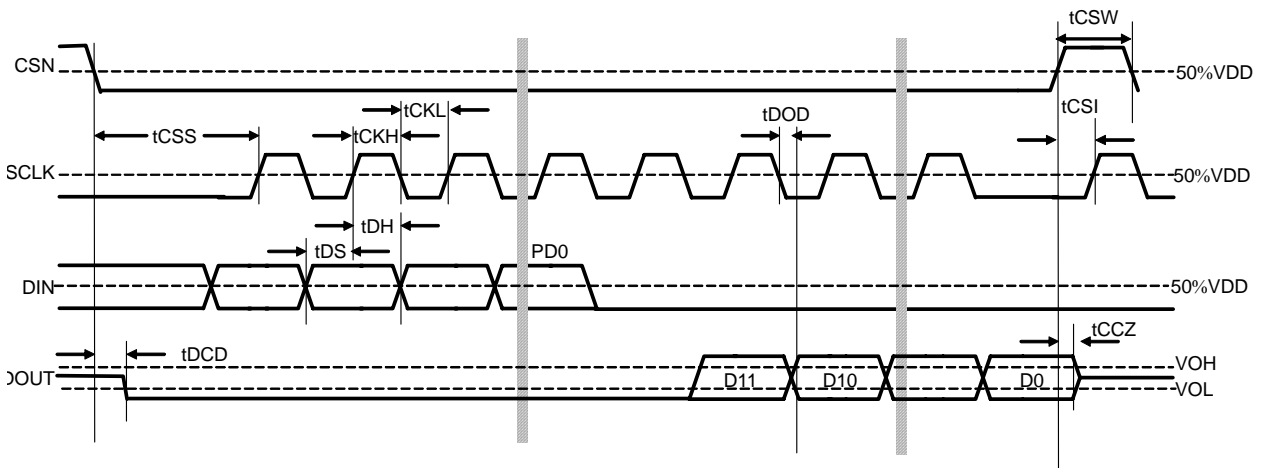

Figure 2. Timing Diagram

OPERATION OVERVIEW

■ Function Overview

The AK4185 consists of the following blocks:

- 1.6V Successive Approximation Resister (SAR) A/D converter
- 4-wire or 5-wire resistive touch screen controller interface
- Single or Continuous A/D conversion
- SAR A/D Converter conversion clock select function
 - External Clock (SCLK)
 - Internal Clock
- SPI™ I/F

■ A/D Converter for Touch Screen

The AK4185 incorporates a 12bit successive approximation resistor (SAR) A/D converter for position measurement, temperature, and auxiliary input. The architecture is based on capacitive redistribution algorithm, and an internal capacitor array functions as the sample/hold (S/H) circuit.

The SAR A/D converter output is a straight binary format as shown below:

Input Voltage	Output Code
$(\Delta VREF - 1.5LSB) \sim \Delta VREF$	FFFH
$(\Delta VREF - 2.5LSB) \sim (\Delta VREF - 1.5LSB)$	FFEH
-----	-----
0.5LSB ~ 1.5LSB	001H
0 ~ 0.5LSB	000H

$$\Delta VREF: (VREF+) - (VREF-)$$

Table 1. Output Code

The AK4185 can select SCLK of the digital interface and internal clock within oscillator for A/D conversion clock. The full scale ($\Delta VREF$) of the A/D converter depends on the input mode. Position and pen pressure is actually measured by differential mode, then IN and temperature is actually measured by single-ended mode. The AK4185 is controlled by the 8bit serial command on the DIN pin. A/D conversion result is 12bit data output on the DOUT pin.

■ Analog Inputs

Analog input is selected via the A2, A1, and A0 bits in the converter register. If the analog inputs are selected to the X, Y, or Z-axis, at differential mode, the full scale ($\Delta VREF$) is the voltage difference between the non-inverting terminal and the inverting terminal of the measured axis (e.g. X-axis measurement: $(XP) - (XN)$). Analog non-inverting input to A/D converter is the non-inverting terminal of the non-measured axis while the inverting input is the inverting terminal of the measured axis. At single-ended mode, the full scale of A/D converter ($\Delta VREF$) is the external reference voltage (VDD). The analog input of A/D converter (ΔAIN) is the voltage difference between the selected channel (IN, TEMP) and the VSS. In case of external clock mode, tracking time is the period from the falling edge of 5th SCLK to that of 8th SCLK after the detection of START bit during $CSN = "L"$.

If the source impedance of analog input is larger than 600Ω, longer tracking time is required. Then A/D conversion should be started.

■ Position Detection of Touch Screen

1. The Position Detection for 4-wire Touch Screen

The position on the touch screen is detected by taking the voltage of one axis when the voltage is supplied between the two terminals of another axis. At least two A/D conversions are needed to get the two-dimensions (X/Y-axis) position.

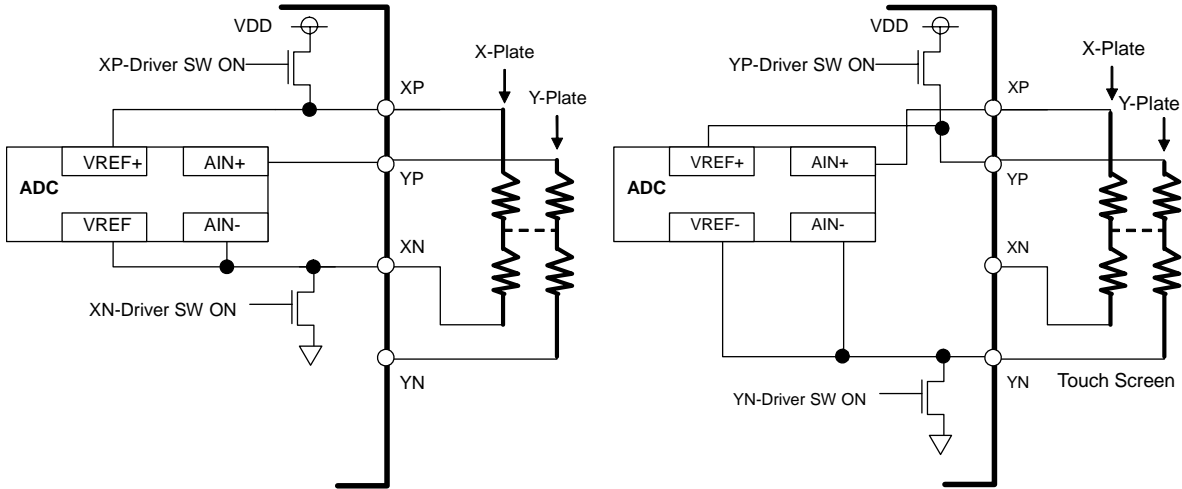

a) X-Position Measurement Differential Mode

b) Y-Position Measurement Differential Mode

The X-plate and Y-plate are connected on the dotted line when the panel is touched.

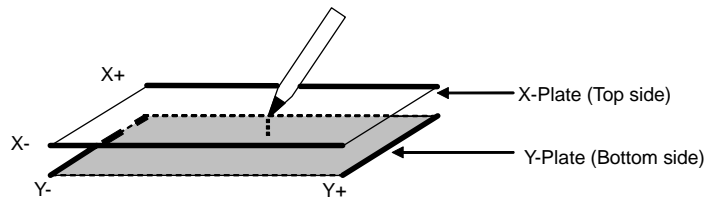

c) 4-wire Touch Screen Construction

Figure 3. Axis Measurements for 4-wire Touch Screen

2. The Position Detection for 5-wire Touch Screen

A 5-wire touch panel consists of one transparent resistive layer and a top metal contact area separated by insulating spacers. The top layer acts only as a voltage measuring probe, the position detection uses the bottom resistive layer that had metal contacts at the 4 corners. When the top layer is pressed by a pen or stylus, the top layer contacts with the bottom layer. Then the X and Y coordinates is detected. The 5-wire touch screen works properly even with damages or scratches on the top layer, therefore the 5-wire touch panel has higher durability than the 4-wire touch panel. Connect the metal contact of the top layer to the WIPER pin, which connected inside of the AK4185, to AIN+ to measure the Y-axis of current position. The top right and top left contacts at the 4 corners are connected to VDD and the bottom right and bottom left contacts connected to VSS. Then the AK4185 initiates A/D conversion of AIN+ input voltage, and Y-axis position is determined.

Terminal	TL	TR	BL	BR
X-axis	VSS	VDD	VSS	VDD
Y-axis	VDD	VDD	VSS	VSS
SW	Switch VDD/VSS	VDD ON/OFF	VSS ON/OFF	Switch VDD/VSS

Table 2. Driver SW configuration

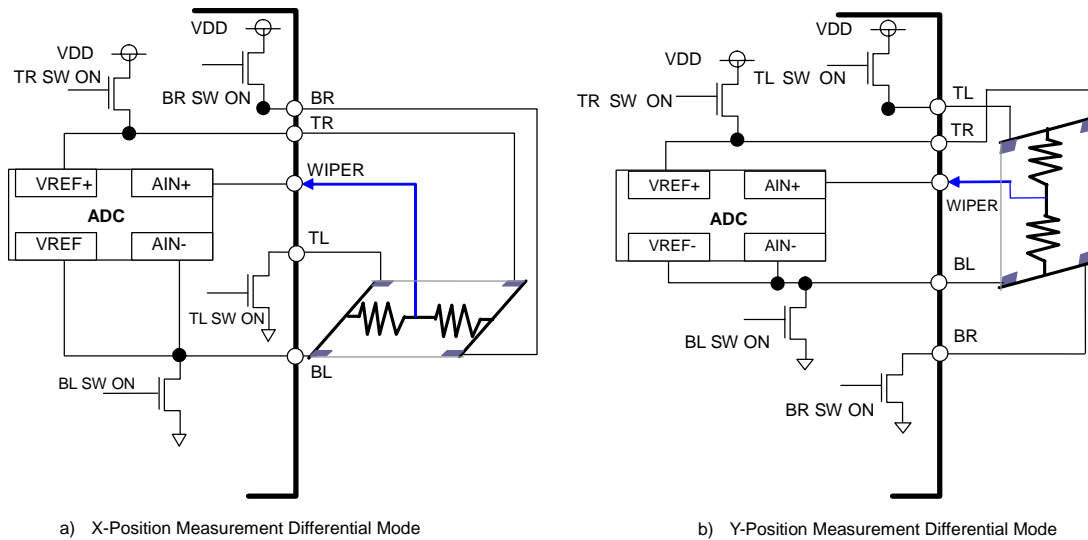

The Top layer and Bottom layer are connected on the dotted line when the panel is touched.

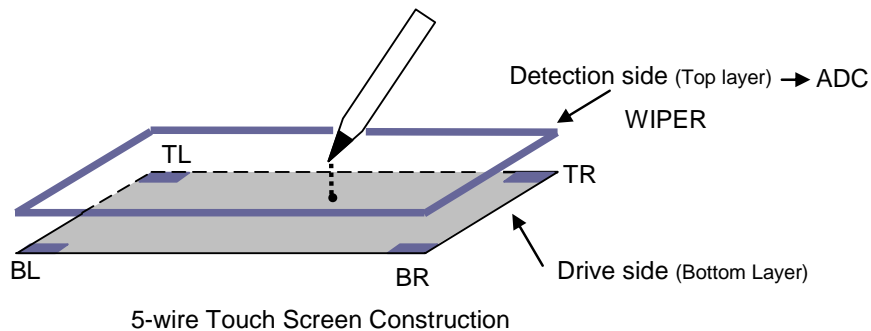

Figure 4. Axis Measurements for 5-wire Touch Screen

■ Pen Pressure Measurement (Only 4-wire Touch Screen)

The touch screen pen pressure can be derived from the measurement of the contact resistor between two plates. The contact resistance depends on the size of the depressed area and the pressure. The area of the spot is proportional to the contact resistance.

This resistance (R_{touch}) can be calculated using two different methods. The first method is that when the total resistance of the X-plate sheet is already known. The resistance, R_{touch} , is calculated from the results of three conversions, X-position, Z1-position, and Z2-position, and then using following formula:

$$R_{TOUCH} = R_{X\text{-plate}} \cdot \frac{X_{\text{Position}}}{4096} \left(\frac{Z_2}{Z_1} - 1 \right)$$

The second method is that when both the resistances of the X-plate and Y-plate are known. The resistance, R_{touch} , is calculated from the results of three conversions, X-position, Y-position, and Z1-position, and then using the following formula:

$$R_{TOUCH} = \frac{R_{X\text{-plate}} \cdot X_{\text{Position}}}{4096} \left(\frac{4096}{Z_1} - 1 \right) - R_{Y\text{-plate}} \cdot \left(1 - \frac{Y_{\text{Position}}}{4096} \right)$$

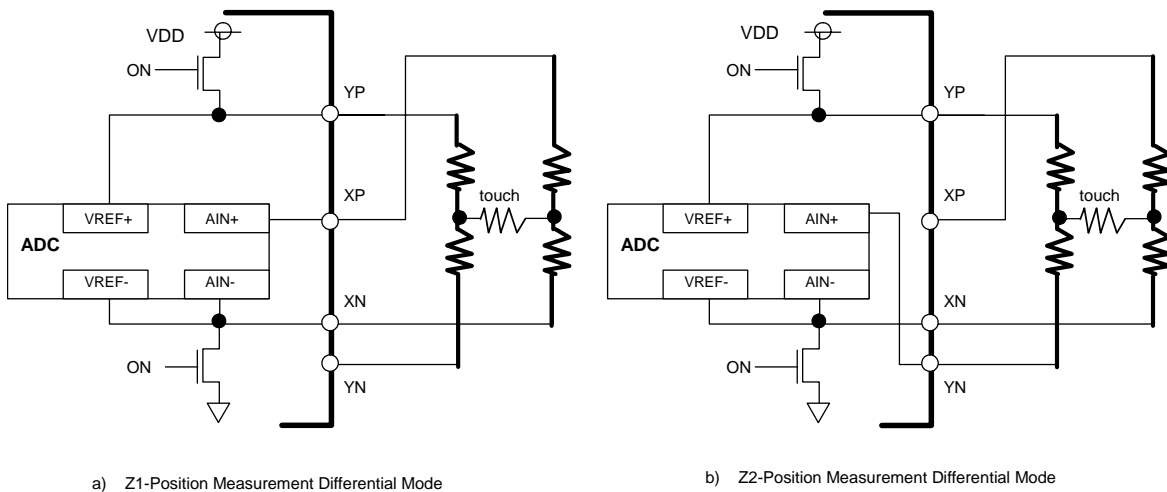

Figure 5. Pen Pressure Measurements

■ Temperature Measurement

Equation <1> describes the forward characteristics of the diode.

$$i_D = I_0 \cdot e^{\left(\frac{V_D}{V_T}\right)} \quad \left(V_T = \frac{kT}{q}\right) \quad <1>$$

- I_0 : reverse saturation current
- q : 1.602189×10^{-19} (electron charge)
- k : 1.38054×10^{-23} (Boltzmann's constant)
- V_D : voltage across diode
- T : absolute temperature K

The diode characteristic is approximately shown as a diode junction voltage. That is theoretically to the temperature; the ambient temperature can be predicted by knowing this voltage.

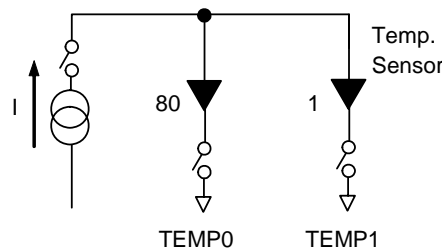

Figure 6. Temperature Measurement

As the AK4185 has two different fixed current circuits and a diode (temperature sensor), the temperature can be measured by using two different methods.

The first method needs two conversions, but can derive the temperature directly without knowing the voltage at a specific temperature.

From equation <1>

$$\left(\frac{i_{D1}}{i_{D0}}\right) = \left(\frac{\frac{I}{80}}{\frac{I}{1}}\right) = 80 = e^{\left\{\frac{(V(1)-V(80))}{V_T}\right\}}$$

$$T_{[^\circ C]} = \Delta V_{be} \cdot \frac{q}{k \cdot \ln(80)} - 273$$

$$\Delta V_{be} = V(1) - V(80)$$

$$T_{[^\circ C]} = 2.648 \times 10^3 \times \Delta V_{be} - 273$$

The second method needs only one conversion as the following equation, but requires knowing the junction voltage at the specific temperature.

$$T = \left(\frac{k}{q}\right) \cdot \frac{V_D}{\ln\left(\frac{i_D}{I_0}\right)} \quad <2>$$

■ Digital I/F

The AK4185 operates with the microprocessor via SPI™ bus. The microprocessor starts to transmit data synchronized with serial clock. The AK4185 operates off of supply voltage down to 1.6V in order to connect a low voltage microprocessor.

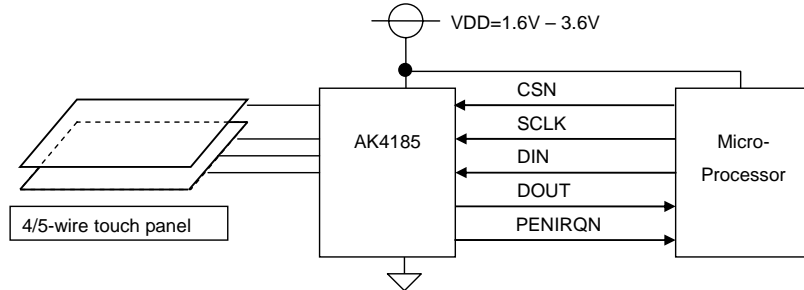

Figure 7. Digital I/F

Standard Sequence: 8bit Control Command

However Setup Command (write) writes Setup Function (4bit) after 8bit Control Command.

1. A/D Data Read

(1) External Clock Mode (Single Read)

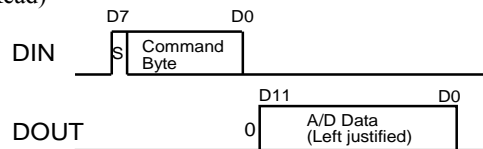
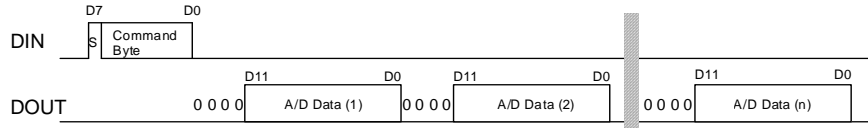

Figure 8. Single Read (External Clock Mode)

(2) External Clock Mode (Continuous Read)

DDLY bit = "0"



* In 8bit output mode, the A/D data is LSB justified.

Figure 9. Continuous Read (External Clock Mode: DDLY bit = "0")

DDLY bit = "1"

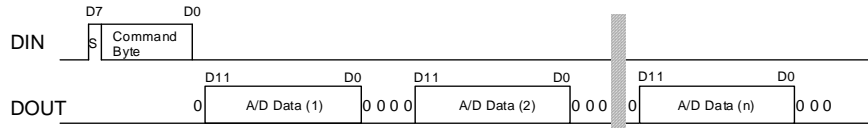

** In 8bit output mode, the A/D data is MSB justified.

Figure 10. Continuous Read (External Clock Mode: DDLY bit = "1")

(3) Internal Clock Mode (Sequential Mode: X-Y-Z1-Z2)

DDLY bit = "0"

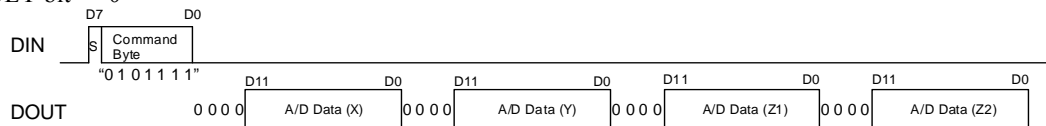

Figure 11. Sequential Read (Internal Clock Mode: DDLY bit = "0")

DDLY bit = "1"

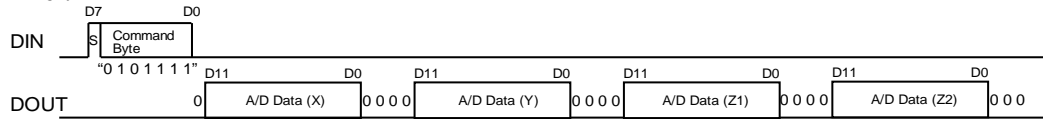

Figure 12. Sequential Read (Internal Clock Mode: DDLY bit = "1")

2. Setup Command

* DIN must keep low state for minimum 7SCLK times (9th-15th SCLK) after command is sent on the DIN.

(1) Setup Command Write

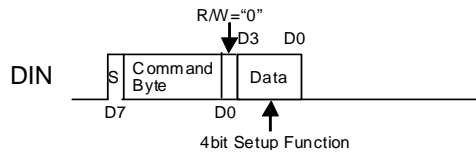

Figure 13. Setup Command Write

(2) Setup Command Read

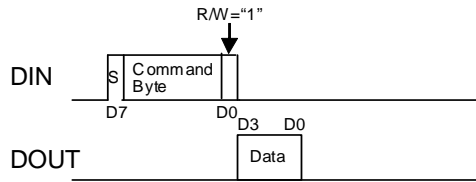

Figure 14. Setup Command Read

■ Control Command

This command can select the touch panel and ADC conversion clock. This 8bit control command includes channel selection, resolution, and power-down mode, and outputs in synchronization of the falling edge of SCLK after CSN = “L”. The AK4185 latches the serial command at the rising edge of SCLK.

Refer to the control command of the AK4185 as shown in [Table 4](#).

D7	D6	D5	D4	D3	D2	D1	D0
S	A2	A1	A0	MODE	x1	x2	PD0

Table 3. Command Byte definition (x1, x2: Don't care)

BIT	Name	Function
D7	S	Start Bit. This bit must be “H” because the AK4185 initiates the command recognition.
D6-D4	A2-A0	Channel Selection bit. Analog inputs to the A/D converter, the activated driver switches, and the reference voltage are selected.
D3	MODE	Resolution of A/D converter. 0: 12bit output 1: 8bit output
D2	x1	Don't care
D1	x2	Don't care
D0	PD0	Power-down Mode. (reference to “ ■ Power-down Control ”)

Table 4. Control Command definition

(1) 4-wire touch panel configuration

Channel Selection			Status of Driver Switch		ADC input (Δ AIN)		Reference Voltage (Δ VREF)		Note	Ref. Mode
A2	A1	A0	X-Driver	Y-Driver	AIN+	AIN-	VREF+	VREF-		
0	0	0	OFF	OFF	TEMP0	VSS	VREF	VSS	TEMP0	SER
0	0	1	OFF	ON	XP	YN	YP	YN	Y-axis	DFR
0	1	0	-	-	-	-	-	-	Setup Command (Table 7)	-
0	1	1	XN-ON	YP-ON	XP	XN	YP	XN	Z1 (Pressure)	DFR
1	0	0	XN-ON	YP-ON	YN	XN	YP	XN	Z2 (Pressure)	DFR
1	0	1	ON	OFF	YP	XN	XP	XN	X-axis	DFR
1	1	0	OFF	OFF	IN	VSS	VREF	VSS	AIN	SER
1	1	1	OFF	OFF	TEMP1	VSS	VREF	VSS	TEMP1	SER

Table 5. Control Command List (4-wire)

(2) 5-wire touch panel configuration

TR: VDD ON/OFF, BL: VSS ON/OFF

Channel Selection			Status of Driver Switch		ADC input (Δ AIN)		Reference Voltage (Δ VREF)		Note	Ref. Mode
A2	A1	A0	TR-Driver	BL-Driver	AIN+	AIN-	VREF+	VREF-		
0	0	0	OFF	OFF	TEMP0	VSS	VREF	VSS	TEMP0	SER
0	0	1	ON	ON	WIPER	BL	TR	BL	Y-axis	DFR
0	1	0	-	-	-	-	-	-	Setup Command (Table 7)	-
0	1	1	-	-	-	-	-	-	Reserved	-
1	0	0	-	-	-	-	-	-	Reserved	-
1	0	1	ON	ON	WIPER	BL	TR	BL	X-axis	DFR
1	1	0	-	-	-	-	-	-	Reserved	-
1	1	1	OFF	OFF	TEMP1	VSS	VREF	VSS	TEMP1	SER

Table 6. Control Command List (5-wire) (The combination other than above is invalid.)

(3) Setup Command configuration

BIT	Name	Description
D7	S	Start Bit. This bit must be "H" because the AK4185 initiates the command recognition.
D6-D4	A2-A0	Setup command. must write "010"
D3-D1	Addr	Addr Selection (Table 8) "000": Function 1 (Table 9) "001": Function 2 (Table 10) "010": Function 3 (Table 11) "011": Function 4 (Table 12) "111": Command of internal clock mode
D0	R/W	READ/ WRITE 0: Write (When Addr bits = "111", Sequential Mode is started.) 1: Read (When Addr bits = "111", A/D data is read out.)

Table 7. Setup Command description

Setup Command Function

Addr	NAME	D3	D2	D1	D0
00H	Function 1	PANEL	CONTINUE	COUNT	DDLY
01H	Function 2	SEQM[2:0]			0
02H	Function 3	INTERVAL[2:0]			0
03H	Function 4	SLEEP[1:0]		SEQST[1:0]	
04H	Reserved	0	0	0	0
05H	Reserved	0	0	0	0
06H	Reserved	0	0	0	0
07H	Command	x	x	x	x

Note 9. Do not write "1" data to the bits named "0".

Table 8. Setup Command List (x: Don't care.)

Function 1 [R/W]: External Clock Mode and Internal Clock Mode

BIT	Name	Description
D3	PANEL	Panel type selection. 0: 4-wire (default) 1: 5-wire
D2	CONTINUE	Read Mode selection. (only External Clock Mode) 0: Single (default) 1: Continuous
D1	COUNT	ADC Conversion count. 0: 6 times AD conversion (default) 1: 10 times AD conversion
D0	DDLY	A/D output data format 0: LSB justified. (default) 1: MSB justified.

Table 9. Setup Function 1 description

Function 2 [R/W]: only Internal Clock Mode

BIT	Name	Description
D3-D1	SEQM	Sequence Mode 000: X → Y → Z1 → Z2 Scan (only 4-wire Touch Screen) (default) 001: X → Y Scan 010: X Scan 011: Y Scan 100: Z1 → Z2 Scan (only 4-wire Touch Screen) 101: TEMP0 → TEMP1 110: A-IN (only 4-wire Touch Screen) 111: Reserved
D0		Reserved

Table 10. Setup Function 2 description

Function 3 [R/W]: only Internal Clock Mode

BIT	Name	Description
D3-D1	INTERVAL	Sampling interval times. 000: 0 μ s (default) 001: 5 μ s 010: 10 μ s 011: 20 μ s 100: 50 μ s 101: 100 μ s 110: 200 μ s 111: 500 μ s
D0		Reserved

Table 11. Setup Function 3 description

Function 4 [R/W]: External Clock Mode and Internal Clock Mode

BIT	Name	Description
D3-D2	SLEEP	Sleep Command (Sleep mode is valid after CSN = "H".) 00: Normal Mode (default) 01: Sleep Mode 1 (PENIRQN disabled and output "H". Touch Panel is open.) 10: Sleep Mode 2 (PENIRQN disabled and open. Touch Panel is open.) 11: Reserved
D1-D0	SEQST	Status Bits [Read only] 00: Not Busy 01: Sampling Wait 10: Sequence Busy 11: Data Available

Table 12. Setup Function 4 description

■ Power on Sequence

To fix the internal register, send the control command when first power up. It initiates all registers such as PD0 bit and sequence register. The sequence is that 1) Power On with CSN= "H" or "L" then CSN = "H". 2) Send control command after CSN = "L". 3) CSN = "H" again. Once sending command to fix the internal register after first power up, the state of the AK4185 is held on the same condition as last command issued.

■ Power-down Control

Power-down and pen interrupt function are controlled by PD0 bit. In order to achieve minimum current, it is recommended to set PD0 bit = "0" for automatic power down of the A/D converter after A/D conversion. It is possible to reduce the variation in data by setting PD0 = "1" during measurements. A/D converter keeps power up after every measurement complete.

PD0	Function
0	Auto Power-down Mode A/D converter is automatically powered up at the start of the conversion, and powered down automatically at the end of the conversion. The AK4185 is always powered down at this mode if CSN = "H". All touch screen driver switches except YN or BL switch are turned off and relative pins are open state. Only YN or BL driver switch is turned ON and forced to VSS in this case. PEN interrupt function is enabled except when in the sampling time and conversion time.
1	ADC ON Mode A/D converter is always powered up while CSN = "L". If X-axis or Y-axis is selected as analog input, touch screen driver switches are always turned ON and the current flows through the touch plate if CSN = "L". This is effective if more settling time is required to suppress the electrical bouncing of touch plate. If CSN = "H", A/D converter is always powered down and touch screen driver switches are always off. (Only YN or BL driver switch is turned ON and forced to VSS.) And while CSN = "H", PEN interrupt function is enabled. When CSN state sets from "H" to "L", the input channel and driver switches is set to the last setting.

Table 13. Power-down Control

■ Sleep Mode

The AK4185 supports sleep mode that puts touch panel to open state and disables pen interrupt function, effective for reducing power consumption caused by unnecessary pen touch.

The AK4185 changes to sleep mode when the micro-controller writes to SLEEP1-0 bits of AK4185's register. After writing the sleep command, this sleep mode starts when the CSN pin is "H". The AK4185 returns to normal operation out of sleep mode when the CSN pin is "L" and receives the normal control command.

SLEEP[1:0]	CSN = "L"		CSN = "H"	
	PENIRQN	Touch Panel	PENIRQN	Touch Panel
00	Normal Operation	Normal Operation	Normal Operation	Normal Operation
01	Normal Operation	Normal Operation	Disable (PENIRQN=H)	Open
10	Normal Operation	Normal Operation	Disable (PENIRQN=Hi-z)	Open
11	-	-	-	-

Table 14. Sleep Mode

CONTROL SEQUENCE

■ Touch Screen Controller Control Sequence (External Clock Mode)

(1) Single Mode (CONTINUE bit = "0")

The timing of sampling and A/D conversion is shown in [Figure 15](#) and [Figure 16](#). The AK4185 is controlled via 4-wire serial interface (CSN, SCLK, DIN, and DOUT pins). The DOUT pin changes to "L" from Hi-Z state at the falling edge of CSN. The AK4185 latches the 8bit control word serially via the DIN pin at the rising edge of SCLK. The DIN pin must keep low state for minimum 7SCLK times (9th-15th SCLK) after command is sent on the DIN pin. As the AK4185 starts the command decoding at the first "H" bit after CSN = "↓", MSB (S bit) of the command must be "H". Tracking time is the period from the falling edge of 5th SCLK to the falling edge of 8th SCLK. The SAR A/D conversion is synchronized with SCLK. The AK4185 outputs 12bit or 8bit A/D data with MSB first via the DOUT pin from the falling edge of 9th SCLK. The AK4185 can output one A/D data per 15 SCLK clock cycles for the fastest way as shown in the dotted line. Please see "[Switching Characteristics](#)" for the detail.

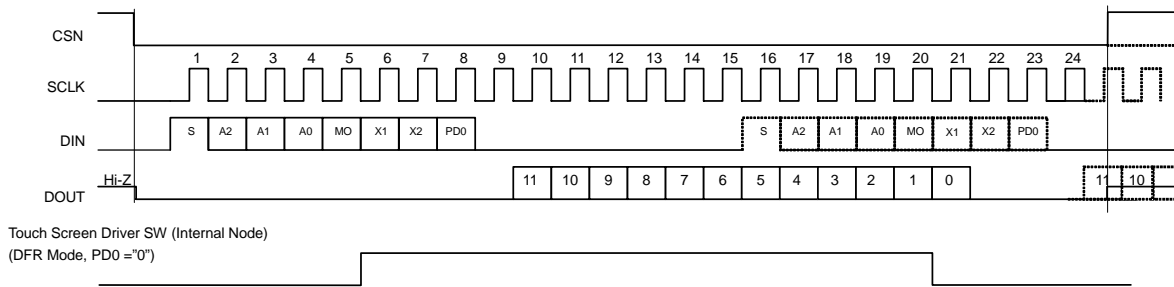

Figure 15. External Clock Mode Control Sequence (Single 12bit Mode)

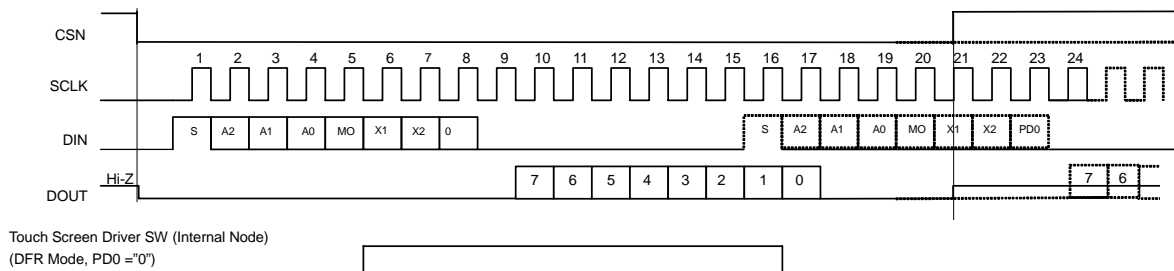

Figure 16. External Clock Mode Control Sequence (Single 8bit Mode)

(2) Continuous Mode (CONTINUE bit = “1”)

The timing of sampling and A/D conversion is shown in Figure 17 and Figure 18. The DOUT pin changes to “L” from Hi-Z state at the falling edge of CSN. The AK4185 latches the 8bit control word serially via the DIN pin at the rising edge of SCLK. Tracking time is the period from the falling edge of the 5th SCLK to the falling edge of the 8th SCLK. The SAR A/D conversion is synchronized with SCLK from the falling edge of the 9th SCLK.

If DDLY bit = “0”, the AK4185 outputs 12bit A/D data with MSB first from the falling edge of the 12th SCLK. In this mode, the AK4185 continuously outputs A/D data according to the number of times by COUNT bit (6 or 10 times A/D conversion) from the falling edge of the 8th SCLK per 16SCLK cycles. (12bit MSB first, LSB justified)

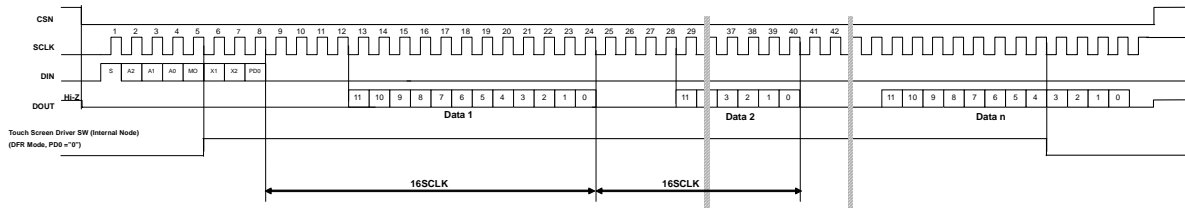

Figure 17. External Clock Mode Control Sequence (Continuous Mode: DDLY bit = “0”)

If DDLY bit = “1”, the AK4185 outputs MSB first 12bit A/D data from the falling edge of the 9th SCLK. In this mode, the AK4185 continuously outputs A/D data according to the number of times by COUNT bit (6 or 10 times A/D conversion) from the falling edge of the 9th SCLK per 16SCLK cycles. (12bit MSB first, MSB justified) The A/D data output timing is the same as Single Mode.

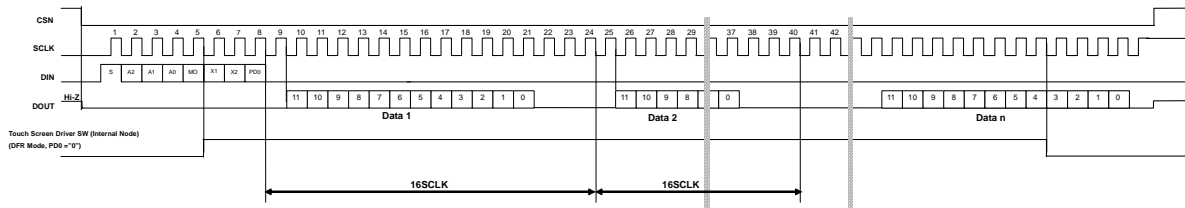

Figure 18. External Clock Mode Control Sequence (Continuous Mode: DDLY bit = “1”)

If PD0 bit sets to “1” in continuous mode, A/D converter is powered up between A/D conversions. It helps A/D data variation to decrease.

In continuous mode, when the AK4185 is executing the operation, the AK4185 ignores all control commands. The AK4185 can receive the next control command from the rising edge of the 96th SCLK (COUNT bit = “0”) or the 160th SCLK (COUNT bit = “1”). When the next control command is sent at the rising edge of the 97th SCLK (COUNT bit = “0”) or the 161st SCLK (COUNT bit = “1”), the AK4185 can output one A/D data per 16 SCLK clock cycles as well as the continuous mode.

■ Touch Screen Controller Control Sequence (Internal Clock Mode)

When the micro-processor sends the sequence start command (10101110b), the AK4185 starts the internal clock mode. The AK4185 sets the PENIRQ pin to “L” and automatically powers up the internal oscillator. Then the AK4185 executes the sequence that selected by SEQM2-0 bits one by one. When the sequence is finished, the AK4185 sets the PENIRQ pin to “H” and notifies that sequence is ended. After 2.8 μ s (typ.) is passed from the rising edge of the PENIRQ pin, the internal oscillator is powered down and PEN interrupt function is enabled.

The micro-controller can confirm that the A/D conversion data is available by checking the PENIRQ pin or reading the status register (SEQST1-0 bits). The micro-processor sends the read command (10101111b) to read the A/D conversion data. Then the AK4185 outputs the A/D data in order of the register selected by SEQM1-0 bits. When the micro-processor reads data as many as more than the actual data number, the AK4185 outputs a zero data. The A/D data is cleared after reading all the A/D data.

Must read the A/D conversion data after confirming the PENIRQ pin turns to “H” or a register status SEQST1-0 = “11”(Data Available). Do not read the A/D conversion data when the data is not available.

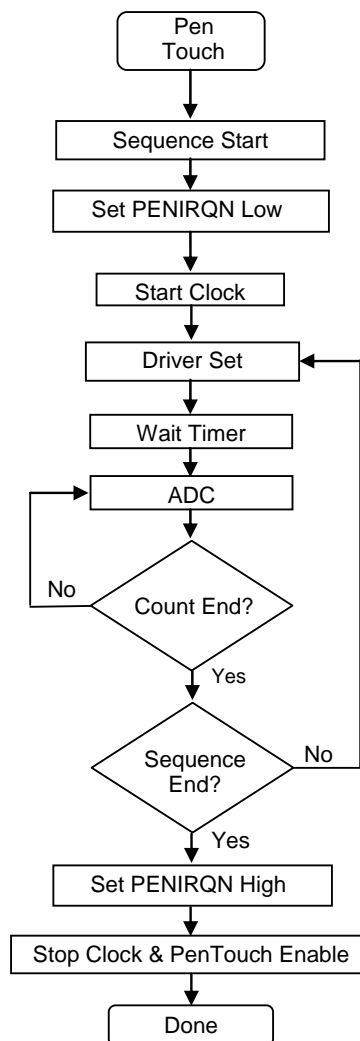

Figure 19. Internal Clock Mode Control Flowchart

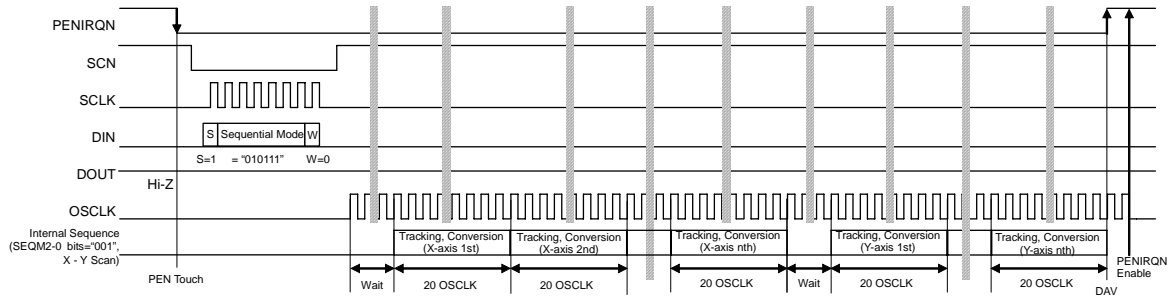

Figure 20. Internal Clock Mode Control Sequence (X-Y Scan: SEQM bits = “001”)
(Sequence Mode Start → Internal Sequence Processing → Data Available)

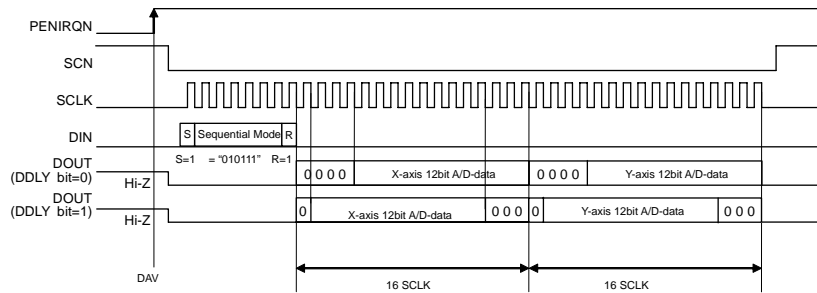

Figure 21. Internal Clock Mode Control Sequence (X-Y Scan: SEQM bits = “001”)
(Data Available → A/D Data Read)

The AK4185 can only accept the Register Read and control commands of A2-0, MODE and PD0 bits for the external clock mode, during executing this sequence. The other commands are ignored. The micro-processor can set CSN = “H” during the sequence. However, the AK4185 can accept sequence commands even if the AK4185 is in the sleep mode. When the sleep mode is selected, the AK4185 goes to the sleep mode after the sequence is finished and CSN = “H”.

■ Pen Interrupt

The AK4185 has pen interrupt function to detect the pen touch. Pen interrupt function is enabled at power-down state. The YN pin (4-wire) or BL pin (5-wire) is connected to VSS at the PEN interrupt enabled state. And the XP pin (4-wire) or WIPER pin (5-wire) is pulled up via an internal resistor (R_{IRQ} : typ.50k Ω). PENIRQN is connected to the XP pin (4-wire) or WIPER pin (5-wire) inside. If touch plate is pressed by a pen, the current flows via <VDD> - <Ri> - <X+> - <Y-> (4-wire). If 5-wire, via <VDD> - <Ri> - <WIPER> - <BL>. The resistance of the plate is generally 1k Ω or less, PENIRQN is forced to “L” level. If the pen is released, PENIRQN returns “H” level because two plates are disconnected, and the current does not flow via two plates.

If the plate is touched with a pen or finger, PENIRQN changes to “L” at CSN = “H” that PENIRQN is normally enable. PENIRQN is disabled during executing internal sequence (please see “[■ Touch Screen Controller Control Sequence \(Internal Clock Mode\)](#)”) and sleep mode is available (please see “[■ Sleep Mode](#)”).

The operation of PENIRQN is related to PD0 bit. PD0 bit is updated at the rising edge of 8th SCLK (please see “[■ Power-down Control](#)” for the detail). Therefore, the last PD0 bit is valid until this timing and during setting the setup command. When CSN is “L”, PENIRQN is disabled during executing internal sequence (please see “[■ Touch Screen Controller Control Sequence \(Internal Clock Mode\)](#)”).

i. The period from CSN \downarrow to the 5th SCLK \downarrow

The behavior of PENIRQN is related to the combination of the last selected analog input channel, and the last PD0 bit. If the last PD0 bit was set to “0”, PENIRQN is “H” while the plate is not pressed and “L” while the plate is pressed regardless of the last analog input. If the last PD0 bit was set to “1”, the last analog input decides the level of PENIRQN. If the last analog input channel is touch screen (X, Y, Z1, Z2 or WIPER), PENIRQN is “L” for all the time in this period regardless of the touched/non-touched state. On the other hand, if the last analog input channel is not touch screen (temperature or auxiliary), PENIRQN is “H” for all the time in this period regardless of the touched/non-touched state.

ii. The period from the 5th SCLK \downarrow to the 20th SCLK \downarrow on CSN = “L” (8bit Mode: to the 16th SCLK \downarrow)

The behavior of PENIRQN is related to the selected analog input and the last PD0 bit. If the current PD0 bit is set to “0” and the touch screen is selected as analog input, PENIRQN is forced to “L” regardless of the touched/non-touched state. If the temperature or auxiliary input is selected as the input channel, PENIRQN is forced to “H” regardless of the touched/non-touched state. If the current PD0 bit is set to “1”, PENIRQN is forced to “H” regardless of the analog input and the touched/non-touched state.

iii. The period from the 20th SCLK \downarrow to CSN \uparrow (8bit Mode: from the 16th SCLK \downarrow to CSN \uparrow)

The behavior of PENIRQN is related to the combination of the current selected analog input channel, and the current PD0 bit. If the current PD0 bit set “0”, PENIRQN is “H” while the plate is not pressed and “L” while the plate is pressed regardless of the current selected analog input. If the current PD0 bit set “1”, the current analog input decides the operation of PENIRQN. If the current analog input channel is touch screen, PENIRQN is “L” for all the time in this period regardless of the touched/non-touched state. On the other hand, if the current analog input is temperature or auxiliary input, PENIRQN is “H” for all the time in this period regardless of the touched/non-touched state.

It is recommended that the micro controller mask the pseudo-interrupts while the control command is issued or A/D data is output.

In continuous mode, AK4185 repeats behavior the period from the 5th SCLK \downarrow to the 21st SCLK \downarrow after output command. Therefore, it must be noted that PENIRQN is valid only 1SCLK (equivalent the period from the 20th SCLK \downarrow to the 21st SCLK \downarrow) when PD0 bit is “0”. Generally recommend to execute continuous mode after PD0 bit is set “1”.

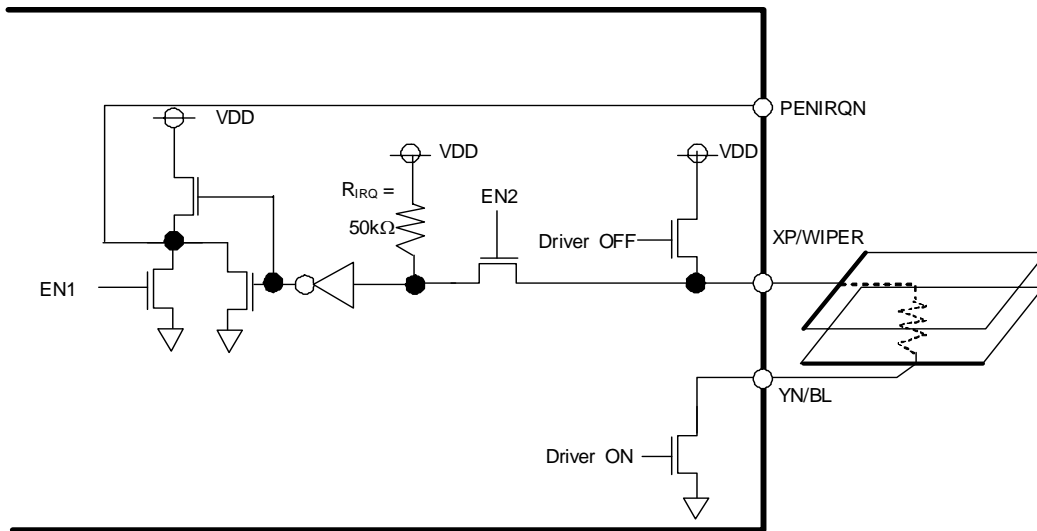

Figure 22. PENIRQN Functional Block Diagram (WIPER does not have a driver.)

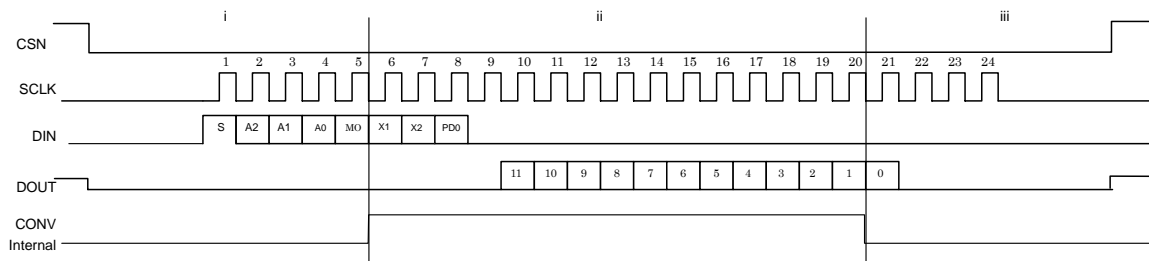

Figure 23. PENIRQN Functional Timing Chart

SYSTEM DESIGN

Figure 24, Figure 25 shows the system connection diagram for the AK4185. The evaluation board [AKD4185] demonstrates the optimum layout, power supply arrangements and measurement results.

<4-wire Touch Screen Input>

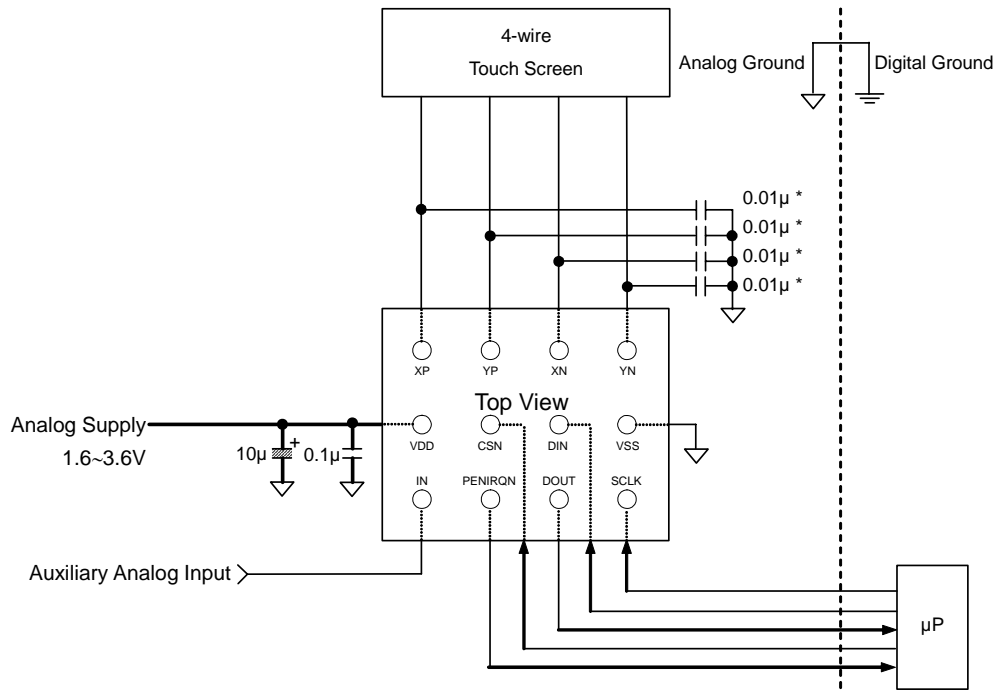

Figure 24. Typical Connection Diagram

Notes:

- VSS of the AK4185 should be distributed separately from the ground of external controllers.
- All digital input pins (CSN, SCLK, DIN pins) must not be left floating.
- The DOUT pin is floating except when communicating with the micro-controller. Therefore, a pull-up or pull-down resistor around 100kΩ must be connected to the DOUT pin of the AK4185.

<5-wire Touch Screen Input>

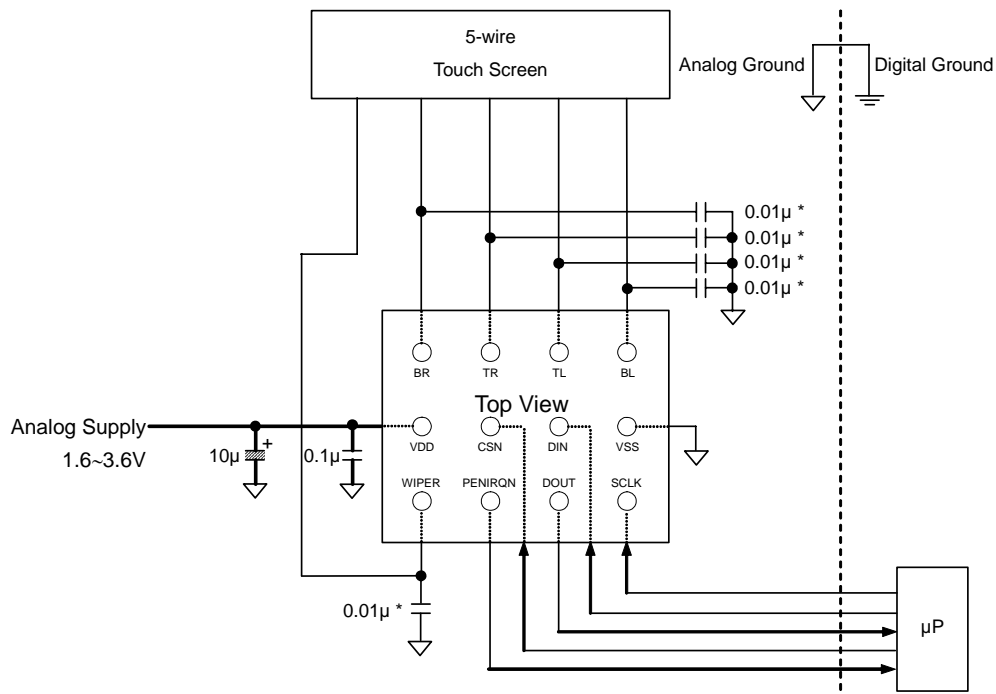

Figure 25. Typical Connection Diagram

Notes:

- VSS of the AK4185 should be distributed separately from the ground of external controllers.
- All digital input pins (CSN, SCLK, DIN pins) must not be left floating.
- The DOUT pin is floating except when communicating with the micro-controller. Therefore, a pull-up or pull-down resistor around 100kΩ must be connected to the DOUT pin of the AK4185.

1. Grounding and Power Supply Decoupling

The AK4185 requires careful attention to power supply and grounding arrangements. VDD is usually supplied from the system's analog supply. VSS of the AK4185 must be connected to the analog ground plane. System analog ground and digital ground should be connected together near to where the supplies are brought onto the printed circuit board.

Decoupling capacitors should be as near to the AK4185 as possible, with the small value ceramic capacitor being the nearest.

2. Analog Inputs

When an EMI source is close to the touch panel analog signal line, EMI noise affects analog characteristics performance. Connect noise canceling capacitors as close as possible to each pin (XP, XN, YP, YN pins) of the AK4185 to avoid this noise. (Figure 24, Figure 25)

PACKAGE

12pin CSP: 1.96mm x 1.46mm

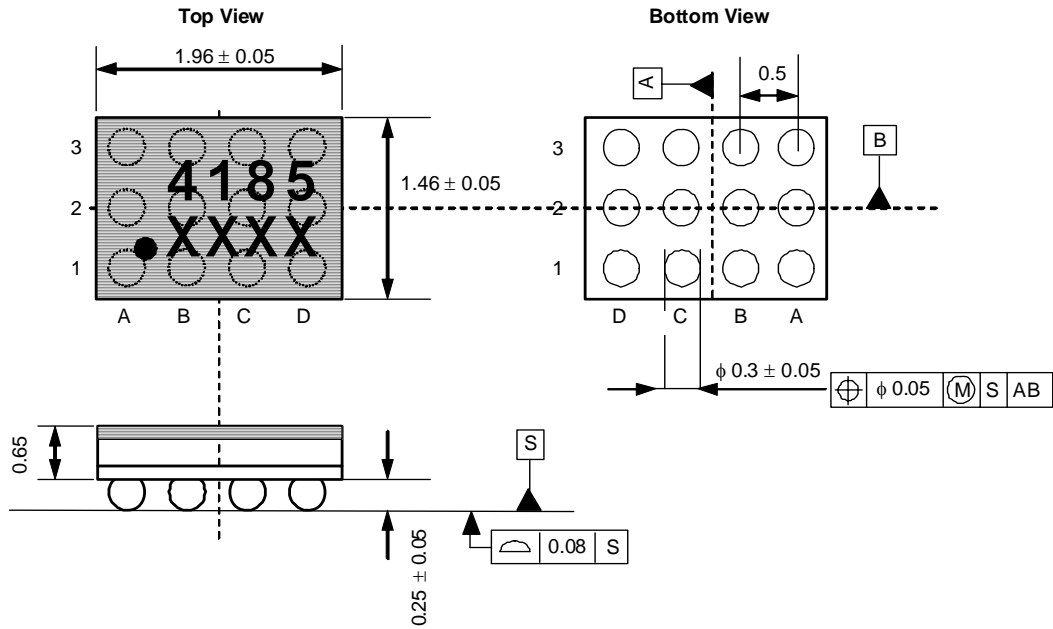

■ Material & Lead finish

Package molding compound: Epoxy resin
 Solder ball material: SnAgCu

MARKING



A1

XXXX: Date code identifier (4 digit)
Pin #A1 indication

REVISION HISTORY

Date (YY/MM/DD)	Revision	Reason	Page	Contents
08/05/09	00	First Edition		

IMPORTANT NOTICE

- These products and their specifications are subject to change without notice.
When you consider any use or application of these products, please make inquiries the sales office of Asahi Kasei EMD Corporation (AKEMD) or authorized distributors as to current status of the products.
- AKEMD assumes no liability for infringement of any patent, intellectual property, or other rights in the application or use of any information contained herein.
- Any export of these products, or devices or systems containing them, may require an export license or other official approval under the law and regulations of the country of export pertaining to customs and tariffs, currency exchange, or strategic materials.
- AKEMD products are neither intended nor authorized for use as critical components_{Note1} in any safety, life support, or other hazard related device or system_{Note2}, and AKEMD assumes no responsibility for such use, except for the use approved with the express written consent by Representative Director of AKEMD. As used here:
 - Note1) A critical component is one whose failure to function or perform may reasonably be expected to result, whether directly or indirectly, in the loss of the safety or effectiveness of the device or system containing it, and which must therefore meet very high standards of performance and reliability.
 - Note2) A hazard related device or system is one designed or intended for life support or maintenance of safety or for applications in medicine, aerospace, nuclear energy, or other fields, in which its failure to function or perform may reasonably be expected to result in loss of life or in significant injury or damage to person or property.
- It is the responsibility of the buyer or distributor of AKEMD products, who distributes, disposes of, or otherwise places the product with a third party, to notify such third party in advance of the above content and conditions, and the buyer or distributor agrees to assume any and all responsibility and liability for and hold AKEMD harmless from any and all claims arising from the use of said product in the absence of such notification.