

GENERAL DESCRIPTION

The AK4122 is a digital sample rate converter (SRC) with the digital audio receiver (DIR). The input sample rate ranges from 8kHz to 96kHz. The output sample rate is 32kHz, 44.1kHz, 48kHz or 96kHz. By using the AK4122, the system can take very simple configuration because the AK4122 has an internal PLL and does not need any master clock at slave mode. Then the AK4122 is suitable for the application interfacing to different sample rates like Car Audio, DVD recorder, etc.

FEATURES

1. SRC

- Asynchronous Sample Rate Converter
- Input Sample Rate Range (fsi) : 8kHz ~ 96kHz
- Output Sample Rate (fso) : 32kHz, 44.1kHz, 48kHz, 96kHz
- Input to Output Sample Rate Ratio : 0.33 to 6
- THD+N : -113dB
- I/F format : MSB justified, LSB justified (16/24bit) and I²S compatible
- Clock for Master mode : 256/384/512/768fs
- SRC Bypass mode
- Soft Mute Function

2. DIR

- 4-Channel Inputs Selector & 1-Channel Through Output
- AES3, IEC60958, S/PDIF, EIAJ CP1201 Compatible
- Low Jitter Analog PLL
- PLL Lock Range : 32kHz ~ 96kHz
- Auto detection
 - Non-PCM Bit Stream
 - DTS-CD Bit Stream
 - Validity Flag
 - Sampling Frequency (32kHz, 44.1kHz, 48kHz, 88.2kHz, 96kHz)
 - Unlock & Parity Error
 - DAT Start ID
- 40-bit Channel Status Buffer
- Burst Preamble bit Pc, Pd Buffer for Non-PCM bit streams
- Q-subcode Buffer for CD bit streams

3. 4-wire Serial μ P Interface

4. Power Supply

- AVDD: 3.0 ~ 3.6V (typ. 3.3V)
- DVDD: 3.0 ~ 3.6V (typ. 3.3V)

5. Ta = -10 ~ 70°C

6. Package : 48pin LQFP

■ Block Diagram

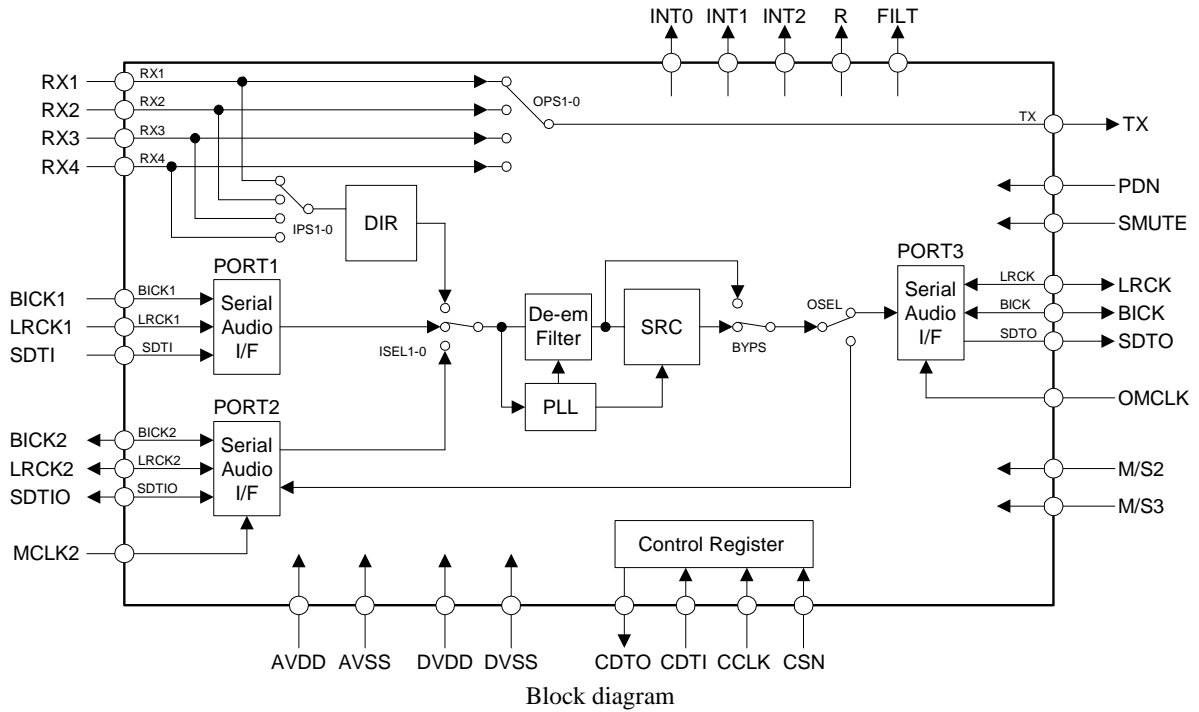

■ Ordering Guide

AK4122VQ
AKD4122

-10 ~ +70°C 48pin LQFP (0.5mm pitch)
Evaluation Board for AK4122

■ Pin Layout

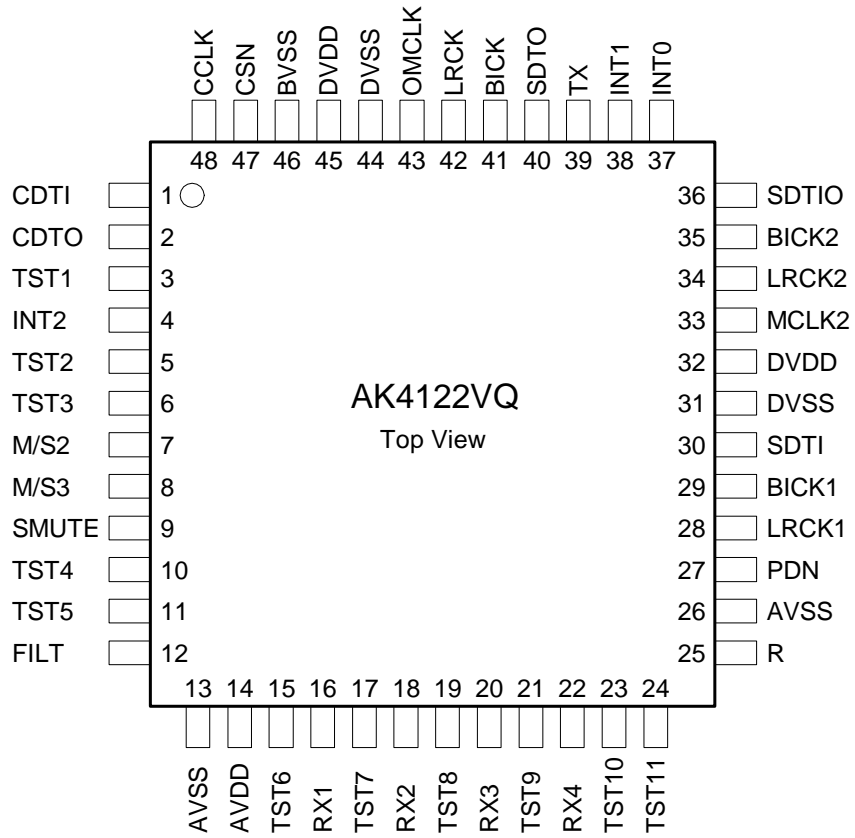

PIN/FUNCTION			
No.	Pin Name	I/O	Function
1	CDTI	I	Control Data Input Pin
2	CDTO	O	Control Data Output Pin
3	TST1	O	Test 1 Pin
4	INT2	O	Interrupt 2 Pin
5	TST2	O	Test 2 Pin
6	TST3	I	Test 3 Pin This pin should be connected to DVSS.
7	M/S2	I	Master / Slave Mode Pin for PORT2 “H” : Master mode, “L” : Slave Mode
8	M/S3	I	Master / Slave Mode Pin for PORT3 “H” : Master mode, “L” : Slave Mode
9	SMUTE	I	Soft Mute Pin “H” : Soft Mute, “L” : Normal Operation
10	TST4	I	Test 4 Pin This pin should be connected to AVSS.
11	TST5	I	Test 5 Pin This pin should be connected to AVSS.
12	FILT	O	PLL Loop Filter Pin 470Ω±5% resistor and 2.2μF±50% ceramic capacitor in parallel with a 2.2nF±50% ceramic capacitor should be connected to AVSS externally.
13	AVSS	-	Analog Ground Pin
14	AVDD	-	Analog Power Supply Pin, 3.0 ~ 3.6V
15	TST6	I	Test 6 Pin This pin should be connected to AVSS.
16	RX1	I	Receiver Input 1 Pin with Amp for 0.2Vpp (Internal Biased Pin)
17	TST7	I	Test 7 Pin This pin should be connected to AVSS.
18	RX2	I	Receiver Input 2 Pin with Amp for 0.2Vpp (Internal Biased Pin)
19	TST8	I	Test 8 Pin This pin should be connected to AVSS.
20	RX3	I	Receiver Input 3 Pin with Amp for 0.2Vpp (Internal Biased Pin)
21	TST9	I	Test 9 Pin This pin should be connected to AVSS.
22	RX4	I	Receiver Input 4 Pin with Amp for 0.2Vpp (Internal Biased Pin)
23	TST10	I	Test 10 Pin This pin should be connected to AVSS.
24	TST11	O	Test 11 Pin

Note: All input pins except internal biased pins should not be left floating.

25	R	-	External Resistor Pin 12kΩ±5% resistor should be connected to AVSS externally.
26	AVSS	-	Analog Ground Pin
27	PDN	I	Power-Down Mode Pin “H”: Power up, “L”: Power down reset and initializes the control register.
28	LRCK1	I	Input Channel Clock Pin
29	BICK1	I	Audio Serial Data Clock Pin
30	SDTI	I	Audio Serial Data Input Pin
31	DVSS	-	Digital Ground Pin
32	DVDD	-	Digital Power Supply Pin, 3.0 ~ 3.6V
33	MCLK2	I	Master Clock Input Pin
34	LRCK2	I/O	Input / Output Channel Clock Pin
35	BICK2	I/O	Audio Serial Data Clock Pin
36	SDTIO	I/O	Audio Serial Data Input / Output Pin
37	INT0	O	Interrupt 0 Pin
38	INT1	O	Interrupt 1 Pin
39	TX	O	Transmitter Output Pin
40	SDTO	O	Audio Serial Data Output Pin
41	BICK	I/O	Audio Serial Data Clock Pin
42	LRCK	I/O	Output Channel Clock Pin
43	OMCLK	I	Master Clock Input Pin
44	DVSS	-	Digital Ground Pin
45	DVDD	-	Digital Power Supply Pin, 3.0 ~ 3.6V
46	BVSS	-	Substrate Ground Pin This pin should be connected to AVSS.
47	CSN	I	Chip Select Pin
48	CCLK	I	Control Data Clock Pin

Note: All input pins except internal biased pins should not be left floating.

■ Handling of Unused pins

The unused digital I/O pins should be processed appropriately as below.

Classification	Pin Name	Setting
PORT1	BICK1, LRCK1, SDTI	These pins should be connected to DVSS.
PORT2	MCLK2	This pin should be connected to DVSS.
	BICK2, LRCK2	These pins should be connected to DVSS in slave mode or open in master mode.
	SDTIO	This pin should be connected to DVSS.
	M/S2	This pin should be connected to DVDD or DVSS.
PORT3	OMCLK	This pin should be connected to DVSS.
	BICK, LRCK	These pins should be connected to DVSS in slave mode or open in master mode.
	SDTO	This pin should be open.
	M/S3	This pin should be connected to DVDD or DVSS.
DIR	RX1, RX2, RX3, RX4	These pins should be open.
	INT0, INT1, INT2, TX	These pins should be open.
Control PORT	CSN, CCLK, CDTI	These pins should be connected to DVSS.
	CDTO	This pin should be open.
Other	SMUTE	This pin should be connected to DVSS.
TEST	TST1, TST2, TST11	These pins should be open.
	TST3	This pin should be connected to DVSS.
	TST4, TST5, TST6, TST7, TST8, TST9, TST10	These pins should be connected to AVSS.

ABSOLUTE MAXIMUM RATINGS

(AVSS, BVSS, DVSS=0V; Note 1)

Parameter		Symbol	min	max	Units
Power Supplies:	Analog	AVDD	-0.3	4.6	V
	Digital	DVDD	-0.3	4.6	V
	BVSS - DVSS (Note 2)	Δ GND	-	0.3	V
Input Current, Any Pin Except Supplies		IIN	-	\pm 10	mA
Digital Input Voltage 1 (Except RX1-4 pins)		VIND1	-0.3	DVDD+0.3	V
Digital Input Voltage 2 (RX1-4 pins)		VIND2	-0.3	AVDD+0.3	V
Ambient Temperature (Power applied)		Ta	-10	70	°C
Storage Temperature		Tstg	-65	150	°C

Note 1. All voltages with respect to ground.

Note 2. AVSS, BVSS and DVSS must be connected to the same ground.

WARNING: Operation at or beyond these limits may result in permanent damage to the device.
Normal operation is not guaranteed at these extremes.

RECOMMENDED OPERATING CONDITIONS

(AVSS, BVSS, DVSS=0V; Note 1)

Parameter		Symbol	min	typ	max	Units
Power Supplies (Note 3)	Analog	AVDD	3.0	3.3	3.6	V
	Digital	DVDD	3.0	3.3	AVDD	V

Note 1. All voltages with respect to ground.

Note 3. The power up sequence between AVDD and DVDD is not critical.

WARNING: AKM assumes no responsibility for the usage beyond the conditions in this datasheet.

SRC CHARACTERISTICS

(Ta=25°C; AVDD=DVDD=3.3V; AVSS=BVSS=DVSS=0V; data = 24bit; measurement bandwidth = 20Hz ~ FSO/2; unless otherwise specified.)

Parameter	Symbol	min	typ	max	Units
SRC Characteristics:					
Resolution (Note 4)				24	Bits
Input Sample Rate	FSI	8		96	kHz
Output Sample Rate	FSO	32		96	kHz
THD+N (Input = 1kHz, 0dBFS, Note 5)					
FSO/FSI = 44.1kHz/48kHz		-	-113	-	dB
FSO/FSI = 48kHz/44.1kHz		-	-113	-	dB
FSO/FSI = 32kHz/48kHz		-	-114	-	dB
FSO/FSI = 96kHz/32kHz		-	-111	-	dB
Worst Case (FSO/FSI = 48kHz/8kHz)		-	-	-103	dB
Dynamic Range (Input = 1kHz, -60dBFS, Note 5)					
FSO/FSI = 44.1kHz/48kHz		-	114	-	dB
FSO/FSI = 48kHz/44.1kHz		-	115	-	dB
FSO/FSI = 32kHz/48kHz		-	115	-	dB
FSO/FSI = 96kHz/32kHz		-	116	-	dB
Worst Case (FSO/FSI = 32kHz/44.1kHz)		112	-	-	dB
Dynamic Range (Input = 1kHz, -60dBFS, A-weighted, Note 5)					
FSO/FSI = 44.1kHz/48kHz		-	117	-	dB
Ratio between Input and Output Sample Rate (Note 6)	FSO/FSI	0.33		6	-

Note 4. Input data for SRC corresponds to 24bit data. When LSB 4bit data is input, the AK4122 calculates as "0" data because SRC is 20bit calculation. Therefore, SRC outputs "0" data.

Note 5. Measured by ROHDE & SCHWARZ UPD04, Rejection Filter = wide, 8192point FFT.

Note 6. The "0.33" is the ratio of FSO/FSI when FSI is 96kHz and FSO is 32kHz. The "6" is the ratio of FSO/FSI when FSI is 8kHz and FSO is 48kHz.

S/PDIF RECEIVER CHARACTERISTICS
--

(Ta=25°C; AVDD, DVDD=3.0 ~ 3.6V)

Parameter	Symbol	min	typ	max	Units
Input Resistance	Zin	-	10	-	kΩ
Input Voltage	VTH	200			mVpp
Input Sample Frequency	fs	32	-	96	kHz

FILTER CHARACTERISTICS

(Ta=25°C; AVDD, DVDD=3.0 ~ 3.6V; DEM=OFF)

Parameter	Symbol	min	typ	max	Units	
Digital Filter						
Passband -0.001dB	$0.985 \leq \text{FSO/FSI} \leq 6.000$	PB	0		0.4583FSI	kHz
	$0.905 \leq \text{FSO/FSI} < 0.985$	PB	0		0.4167FSI	kHz
	$0.714 \leq \text{FSO/FSI} < 0.905$	PB	0		0.3195FSI	kHz
	$0.656 \leq \text{FSO/FSI} < 0.714$	PB	0		0.2852FSI	kHz
	$0.536 \leq \text{FSO/FSI} < 0.656$	PB	0		0.2245FSI	kHz
	$0.492 \leq \text{FSO/FSI} < 0.536$	PB	0		0.2003FSI	kHz
	$0.452 \leq \text{FSO/FSI} < 0.492$	PB	0		0.1781FSI	kHz
	$0.333 \leq \text{FSO/FSI} < 0.452$	PB	0		0.1092FSI	kHz
Stopband	$0.985 \leq \text{FSO/FSI} \leq 6.000$	SB	0.5417FSI			kHz
	$0.905 \leq \text{FSO/FSI} < 0.985$	SB	0.5021FSI			kHz
	$0.714 \leq \text{FSO/FSI} < 0.905$	SB	0.3965FSI			kHz
	$0.656 \leq \text{FSO/FSI} < 0.714$	SB	0.3643FSI			kHz
	$0.536 \leq \text{FSO/FSI} < 0.656$	SB	0.2974FSI			kHz
	$0.492 \leq \text{FSO/FSI} < 0.536$	SB	0.2732FSI			kHz
	$0.452 \leq \text{FSO/FSI} < 0.492$	SB	0.2510FSI			kHz
	$0.333 \leq \text{FSO/FSI} < 0.452$	SB	0.1822FSI			kHz
Passband Ripple	PR			±0.01	dB	
Stopband Attenuation	SA	96			dB	
Group Delay (Note 7)	GD	-	58.5	-	1/fs	

Note 7. This value is the time from the rising edge of LRCK after data is input to rising edge of LRCK after data is output, when LRCK for Output data corresponds with LRCK for Input.

DC CHARACTERISTICS

(Ta=25°C; AVDD, DVDD=3.0 ~ 3.6V)

Parameter	Symbol	min	typ	max	Units
High-Level Input Voltage	VIH	70% DVDD	-	-	V
Low-Level Input Voltage	VIL	-	-	30% DVDD	V
High-Level Output Voltage (Iout=-400μA)	VOH	DVDD-0.4	-	-	V
Low-Level Output Voltage (Iout=400μA)	VOL	-	-	0.4	V
Input Leakage Current	Iin	-	-	±10	μA

Parameter	min	typ	max	Units
Power Supply Current				
Normal operation (PDN pin = "H") (Note 8)				
FSI=FSO=48kHz at Slave Mode: AVDD=DVDD=3.3V		15	-	mA
FSI=FSO=96kHz at Master Mode: AVDD=DVDD=3.3V		29	-	mA
FSI=FSO=96kHz at Master Mode: AVDD=DVDD=3.6V		-	45	mA
Power down (PDN pin = "L") (Note 9)				
AVDD+DVDD		10	100	μA

Note 8. Typ and max values are the value of AVDD+DVDD in each power supply voltage.

Power supply current of each path@Slave Mode, AVDD=DVDD=3.3V, FSI=FSO=48kHz

1. PORT1 → SRC → PORT3: AVDD=5mA(typ), DVDD=10mA(typ)
2. PORT2 → SRC → PORT3: AVDD=5mA(typ), DVDD=10mA(typ)
3. DIR → SRC → PORT3: AVDD=6mA(typ), DVDD=9mA(typ)

Note 9. All digital input pins are held DVSS.

SWITCHING CHARACTERISTICS					
(Ta=25°C; AVDD, DVDD=3.0 ~ 3.6V; CL=20pF)					
Parameter	Symbol	min	typ	max	Units
Master Clock Timing					
Frequency	fCLK	8.192		36.864	MHz
Pulse Width Low	tCLKL	0.4/fCLK			ns
Pulse Width High	tCLKH	0.4/fCLK			ns
LRCK for Input data (LRCK1, LRCK2)					
Frequency	fs	8		96	kHz
Duty Cycle	Duty	48	50	52	%
LRCK for Output data (LRCK, LRCK2)					
Frequency (Note 10)	fs	32		96	kHz
Duty Cycle Slave Mode	Duty	48	50	52	%
Duty Cycle Master Mode	Duty		50		%
S/PDIF Clock Recover Frequency					
	fPLL	32		96	kHz
Audio Interface Timing					
Input for PORT1					
BICK1 Period	tBCK	1/64fs			ns
BICK1 Pulse Width Low	tBCKL	65			ns
Pulse Width High	tBCKH	65			ns
LRCK1 Edge to BICK1 “↑” (Note 11)	tLRB	30			ns
BICK1 “↑” to LRCK1 Edge (Note 11)	tBLR	30			ns
SDTI Hold Time from BICK1 “↑”	tSDH	30			ns
SDTI Setup Time to BICK1 “↑”	tSDS	30			ns
Input for PORT2 (Slave mode)					
BICK2 Period	tBCK	1/64fs			ns
BICK2 Pulse Width Low	tBCKL	65			ns
Pulse Width High	tBCKH	65			ns
LRCK2 Edge to BICK2 “↑” (Note 11)	tLRB	30			ns
BICK2 “↑” to LRCK2 Edge (Note 11)	tBLR	30			ns
SDTIO Hold Time from BICK2 “↑”	tSDH	30			ns
SDTIO Setup Time to BICK2 “↑”	tSDS	30			ns
Output for PORT2 (Slave mode)					
BICK2 Period	tBCK	1/64fs			ns
BICK2 Pulse Width Low	tBCKL	65			ns
Pulse Width High	tBCKH	65			ns
LRCK2 Edge to BICK2 “↑” (Note 11)	tLRB	30			ns
BICK2 “↑” to LRCK2 Edge (Note 11)	tBLR	30			ns
LRCK2 to SDTIO (MSB) (Except I ² S mode)	tLRS			30	ns
BICK2 “↓” to SDTIO	tBSD			30	ns

Note 10. Min value is 8kHz at BYPASS mode.

Note 11. BICK1 rising edge must not occur at the same time as LRCK1 edge.
BICK2 rising edge must not occur at the same time as LRCK2 edge.

Parameter	Symbol	min	typ	max	Units
Output for PORT3 (Slave mode)					
BICK Period	tBCK	1/64fs			ns
BICK Pulse Width Low	tBCKL	65			ns
Pulse Width High	tBCKH	65			ns
LRCK Edge to BICK “↑” (Note 11)	tLRB	30			ns
BICK “↑” to LRCK Edge (Note 11)	tBLR	30			ns
LRCK to SDTO (MSB) (Except I ² S mode)	tLRS			30	ns
BICK “↓” to SDTO	tBSD			30	ns
Output for PORT2 (Master mode)					
BICK2 Frequency	fBCK		64fs		Hz
BICK2 Duty	dBCK		50		%
BICK2 “↓” to LRCK2	tMBLR	-20		20	ns
BICK2 “↓” to SDTIO	tBSD	-20		30	ns
Output for PORT3 (Master mode)					
BICK Frequency	fBCK		64fs		Hz
BICK Duty	dBCK		50		%
BICK “↓” to LRCK	tMBLR	-20		20	ns
BICK “↓” to SDTO	tBSD	-20		30	ns
Control Interface Timing					
CCLK Period (Note 12)	tCCK	200		1000	ns
CCLK Pulse Width Low	tCCKL	80			ns
Pulse Width High	tCCKH	80			ns
CDTI Setup Time	tCDS	40			ns
CDTI Hold Time	tCDH	40			ns
CSN “H” Time	tCSW	150			ns
CSN “↓” to CCLK “↑”	tCSS	50			ns
CCLK “↑” to CSN “↑”	tCSH	50			ns
CDTO Delay	tDCD			45	ns
CSN “↑” to CDTO Hi-Z	tCCZ			70	ns
Reset Timing					
PDN Pulse Width (Note 13)	tPD	150			ns

Note 11. BICK rising edge must not occur at the same time as LRCK edge.

Note 12. In case of using INT2. When INT2 is not used, the max value is not limited.

Note 13. The AK4122 can be reset by bringing the PDN pin = “L”.

■ Timing Diagram

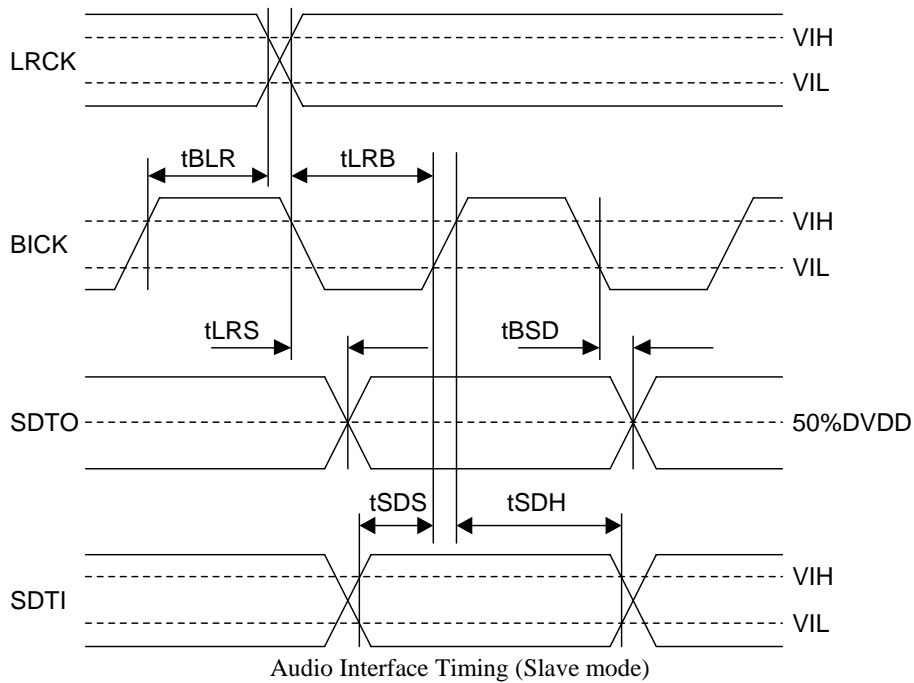
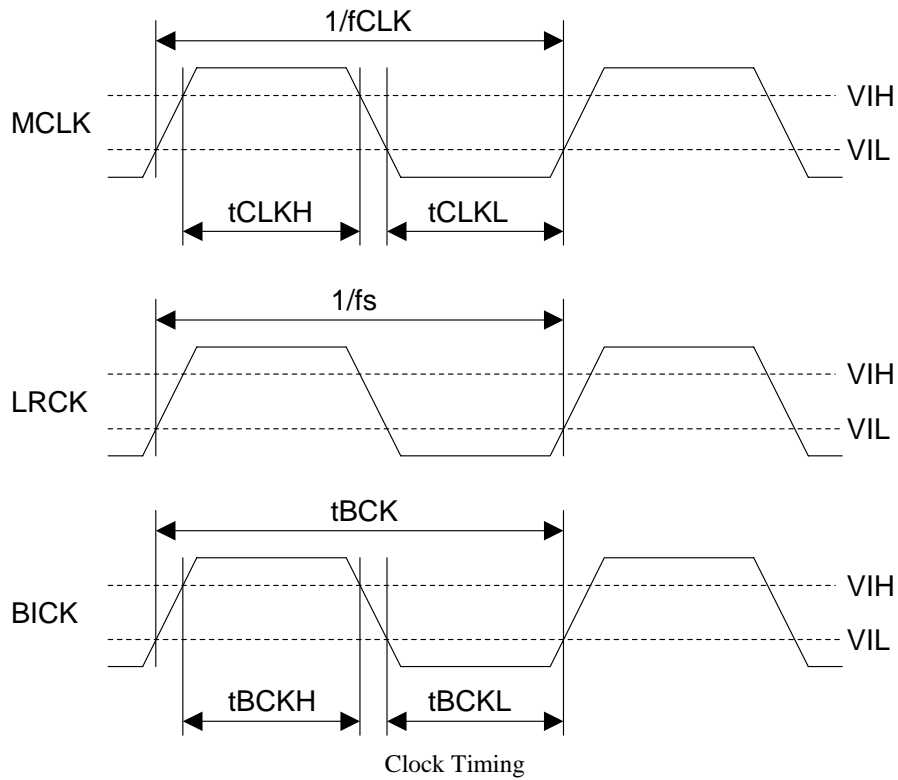

Note : BICK shows BICK1 of PORT1, BICK2 of PORT2 and BICK of PORT3. LRCK shows LRCK1 of PORT1, LRCK2 of PORT2 and LRCK of PORT3. SDTI shows SDTI of PORT1 or SDTIO of PORT2 that is used as input port. SDTO shows SDTO of PORT3 or SDTIO of PORT2 that is used as output port.

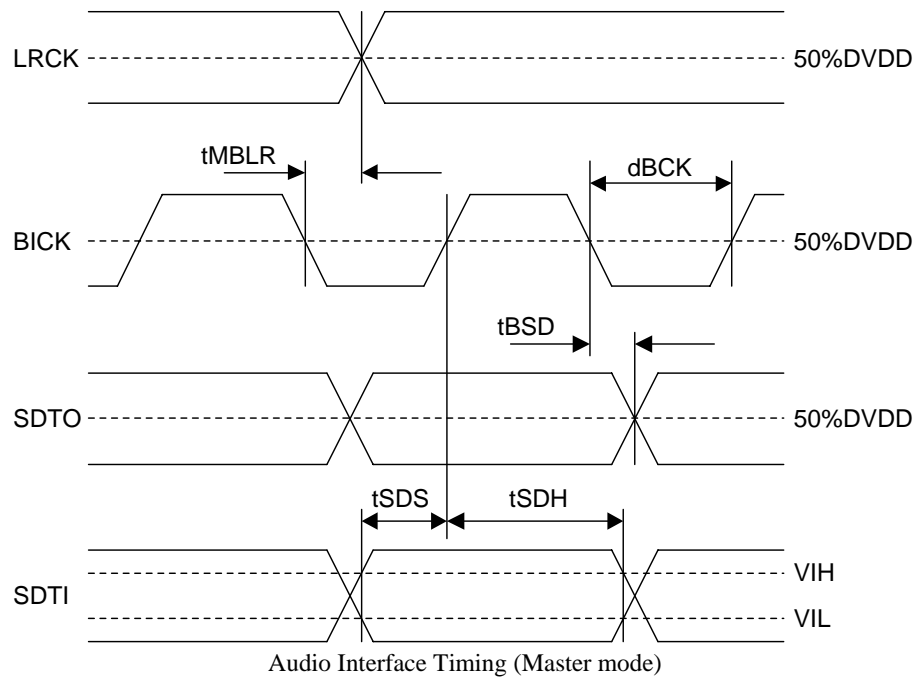

Note : BICK shows BICK1 of PORT1, BICK2 of PORT2 and BICK of PORT3. LRCK shows LRCK1 of PORT1, LRCK2 of PORT2 and LRCK of PORT3. SDTI shows SDTI of PORT1 or SDTIO of PORT2 that is used as input port. SDTO shows SDTO of PORT3 or SDTIO of PORT2 that is used as output port.

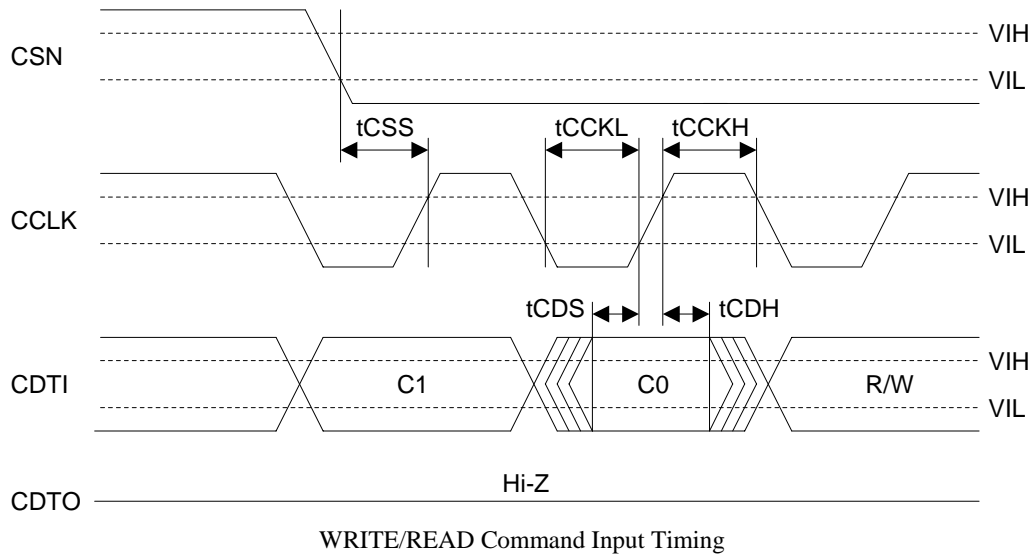

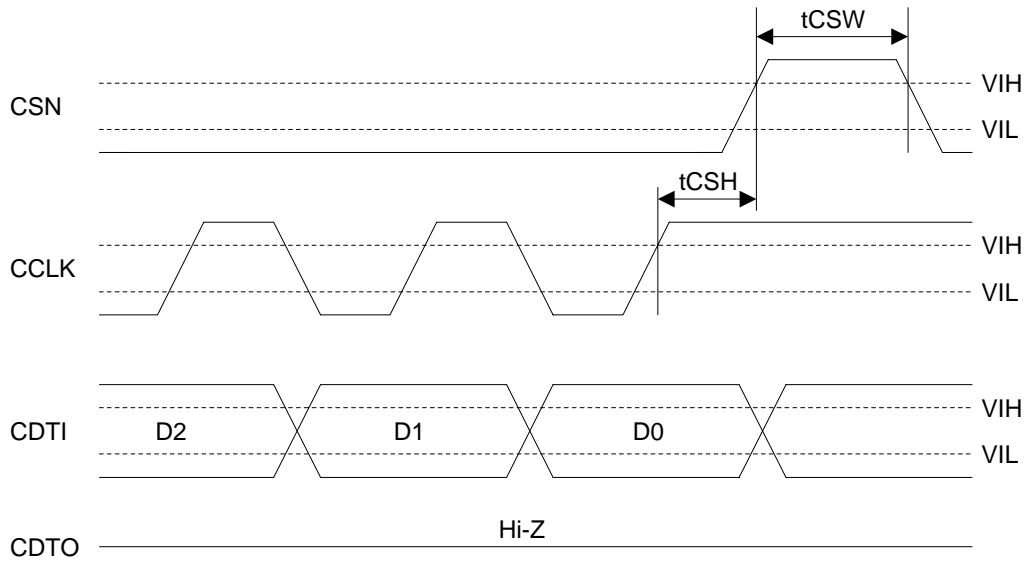

WRITE Data Input Timing

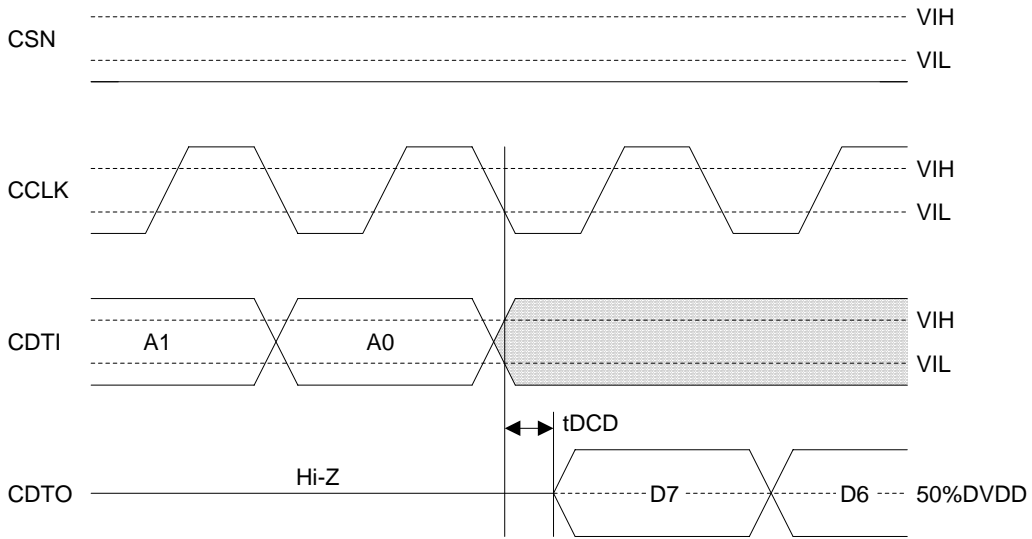

READ Data Output Timing 1

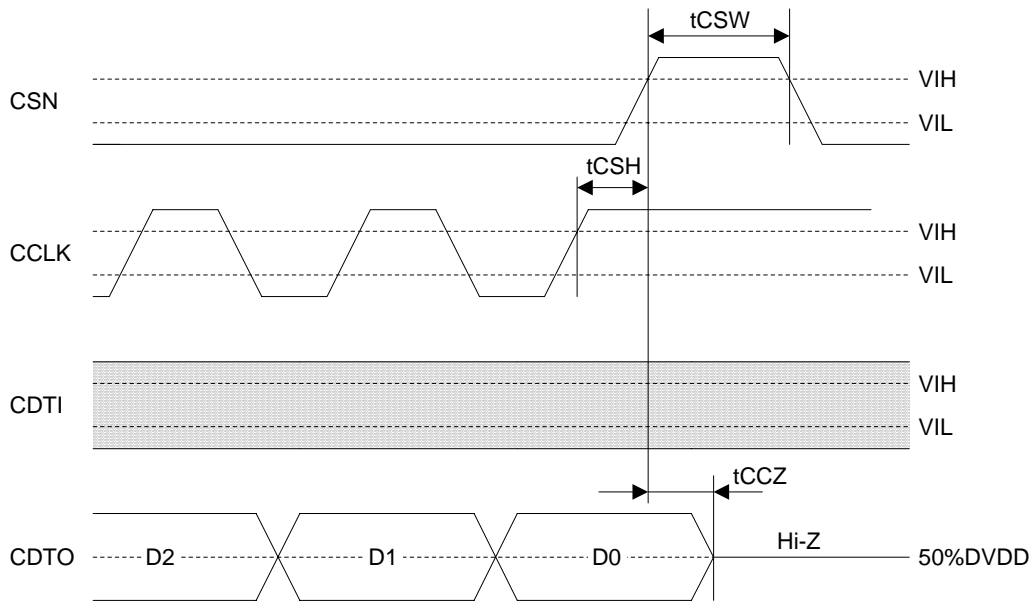

READ Data Output Timing 2

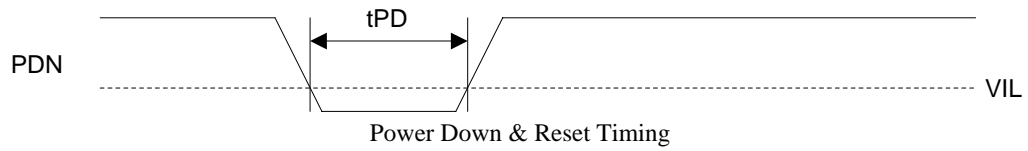

OPERATION OVERVIEW

■ **Internal Signal Path**

The input source of the SRC can be switched between the outputs of the DIR, PORT1 or PORT2. The input source of the PORT2 and PORT3 can be switched between the outputs of the SRC or BYPASS. When PORT2 is used as input port, PORT2 cannot use as output port. The signal path should be controlled during PWN bit = "0". The Switch Names (ISEL1-0 bits etc) in Figure 1 correspond to the register bits that control the switch function. Refer to Table 1.

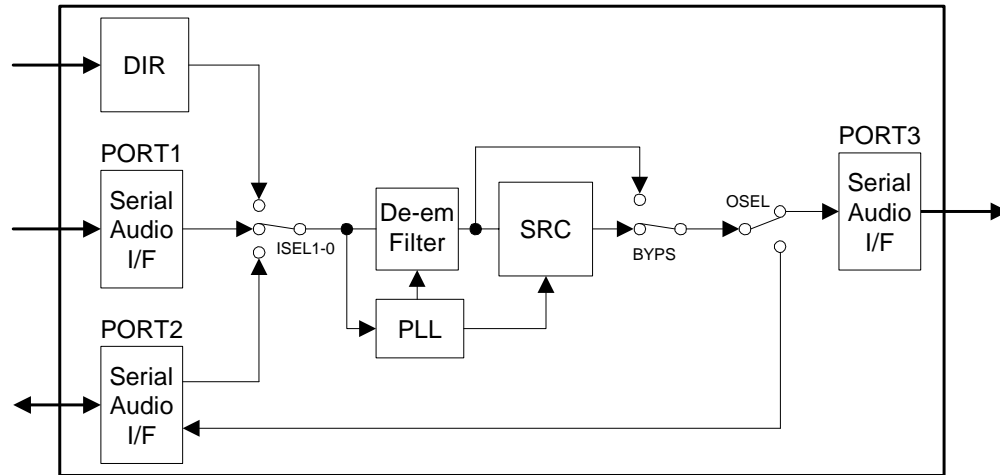

Figure 1. Connection Input Source & Output Source

Mode	Input PORT	SRC / Bypass	Output PORT	Path
	ISEL1-0 bit	BYPS bit	OSEL bit	
0	00 : PORT1	0 : SRC	0 : PORT3 (Note 1)	PORT1 → SRC → PORT3
1	01 : PORT2			PORT2 → SRC → PORT3
2	10 : DIR			DIR → SRC → PORT3
3	00 : PORT1	1 : Bypass		PORT1 → PORT3
4	01 : PORT2			PORT2 → PORT3
5	10 : DIR		DIR → PORT3	
6	00 : PORT1	0 : SRC	1 : PORT2 (Note 2)	PORT1 → SRC → PORT2
7	10 : DIR			DIR → SRC → PORT2
8	00 : PORT1	1 : Bypass		PORT1 → PORT2
9	10 : DIR			DIR → PORT2

Table 1. Path Select

Default is Mode 0. (Path : PORT1 → SRC → PORT3)

After PDN pin = "L" → "H", SDTIO pin of PORT2 is the input pin.

The DIF1-0 bits of the PORT1 should be set a value except "10" (I²S Compatible) when the DIR is selected as an input port.

Refer to Table 6 and 7 for Master/Slave mode setting.

Note 1. In this case, PORT2 is input port. If PORT2 is unused, the digital I/O pins should be processed appropriately by Table 2.

M/S2 pin	Mode	Unused pin	Pin I/O	Setting
L	Slave	MCLK2	I	This pin should be connected to DVSS.
		BICK2	I	This pin should be connected to DVSS.
		LRCK2	I	This pin should be connected to DVSS.
		SDTIO	I	This pin should be connected to DVSS.
H	Master	MCLK2	I	This pin should be connected to DVSS.
		BICK2	O	This pin should be open.
		LRCK2	O	This pin should be open.
		SDTIO	I	This pin should be connected to DVSS.

Table 2. Pin Setting for PORT2

Note 2. In this case, PORT3 is output port. If PORT3 is unused, the digital I/O pins should be processed appropriately by Table 3.

M/S3 pin	Mode	Unused pin	Pin I/O	Setting
L	Slave	OMCLK	I	This pin should be connected to DVSS.
		BICK	I	This pin should be connected to DVSS.
		LRCK	I	This pin should be connected to DVSS.
		SDTO	O	This pin should be open.
H	Master	OMCLK	I	This pin should be connected to DVSS.
		BICK	O	This pin should be open.
		LRCK	O	This pin should be open.
		SDTO	O	This pin should be open.

Table 3. Pin Setting for PORT3

■ System Clock

PORT1 can be operated in slave mode only. PORT2 and PORT3 work in master mode and slave mode. Internal system clock is created by internal PLL using LRCK1, LRCK2 or LRCK of DIR. The MCLK is not needed when PORT2 and PORT3 are in slave mode and then please set MCLK2 pin and OMCLK pin to DVSS. However, when PORT2 and PORT3 are used in master mode, MCLK2 pin and OMCLK pin should be supplied to MCLK. The M/S2 pin and M/S3 pin select between master and slave mode. Table 4 and 5 show setting of MCLK frequency that PORT2 and PORT3 are master mode. In case of detecting the sampling frequency by MCLK when DIR is used, MCLK (MCLK2 or OMCLK) of selected output port (PORT2 or PORT3) should be input.

ICKS1	ICKS0	MCLK2		Default
		32kHz ≤ fs ≤ 48kHz	48kHz < fs ≤ 96kHz	
0	0	256fs	256fs	
0	1	384fs	384fs	
1	0	512fs	N/A	
1	1	768fs	N/A	

Table 4. MCLK2 frequency select for Master mode

OCKS1	OCKS0	OMCLK		Default
		32kHz ≤ fs ≤ 48kHz	48kHz < fs ≤ 96kHz	
0	0	256fs	256fs	
0	1	384fs	384fs	
1	0	512fs	N/A	
1	1	768fs	N/A	

Table 5. OMCLK frequency select for Master mode

■ Master Mode and Slave Mode

When PORT2 and PORT3 are used as output port, the M/S2 pin and M/S3 pin select either master or slave mode. “H” is master mode, “L” is slave mode. In master mode, MCLK should be input and the AK4122 outputs BICK and LRCK. In slave mode, BICK and LRCK are input externally and MCLK is not needed. If PORT2 is used as input port, M/S2 pin should be set “H” or “L”.

M/S2 pin	BYPS bit	Data I/O	Mode	BICK, LRCK
L	0	I/O	Slave, SRC	Input
L	1	Input	Available	
		Output	Not Available	
H	0	I/O	Master, SRC	Output
H	1	I/O	Master, Bypass	

Table 6. Master mode/Slave mode for PORT2

M/S3 pin	BYPS bit	Data I/O	Mode	BICK, LRCK
L	0	Output	Slave, SRC	Input
L	1	Output	Not Available	
H	0	Output	Master, SRC	Output
H	1	Output	Master, Bypass	

Table 7. Master mode/Slave mode for PORT3

■ Audio Interface Format

The audio interface should be controlled during PWN bit = “0”. When in BYPASS mode, BICK1, BICK2 and BICK are fixed to 64fs.

(1) PORT1

Four kinds of data formats can be chosen with the DIF1-0 bits (Table 8). In all modes, the serial data is in MSB first, 2’s compliment format. The SDTI is latched on the rising edge of BICK1. PORT1 corresponds to slave mode only.

Mode	DIF1	DIF0	Input Format	LRCK	BICK	
0	0	0	16bit, LSB justified	H/L	≥ 32fs	Default
1	0	1	24bit, MSB justified	H/L	≥ 48fs	
2	1	0	24bit, I ² S Compatible	L/H	≥ 48fs	
3	1	1	24bit, LSB justified	H/L	≥ 48fs	

Table 8. Audio Interface Format for PORT1

Note: The DIF1-0 bits of the PORT1 should be set a value except “10” (I²S Compatible) when the DIR is selected as an input port.

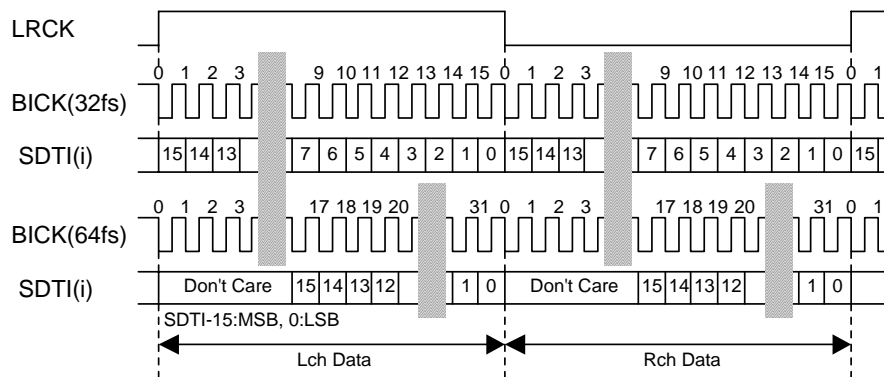

Figure 2. Mode 0 Timing

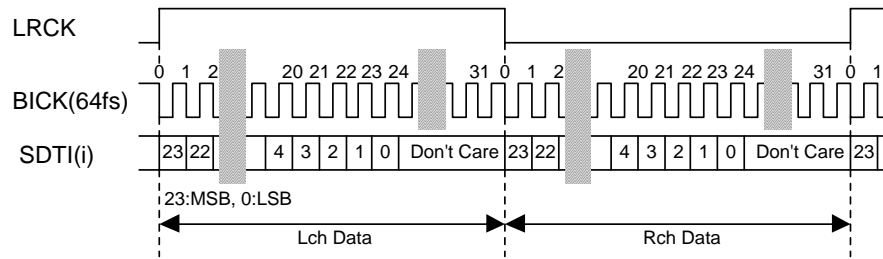

Figure 3. Mode 1 Timing

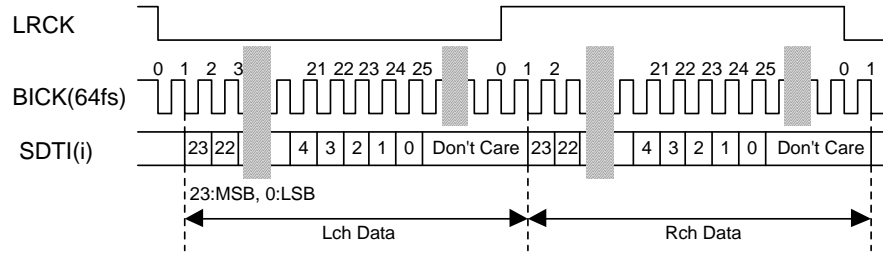

Figure 4. Mode 2 Timing

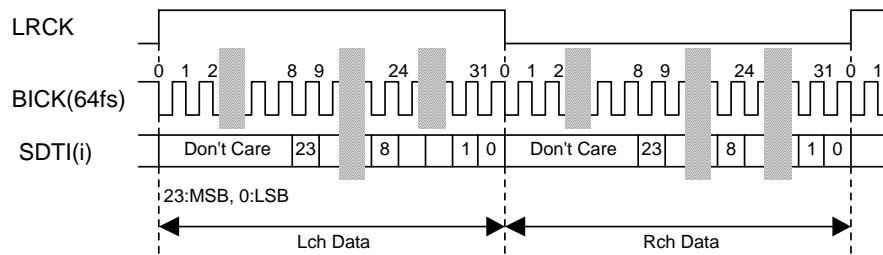

Figure 5. Mode 3 Timing

(2) PORT2

Four kinds of data formats can be chosen with the IDIF1-0 bits (Table 9). In all modes, the serial data is in MSB first, 2's complement format. If PORT2 is selected the output port, the SDTIO is clocked out on the falling edge of BICK2, and if PORT2 is selected the input port, the SDTIO is latched on the rising edge of BICK2. The audio interface supports both master and slave modes. In master mode, BICK2 and LRCK2 are output with the BICK2 frequency fixed to 64fs and the LRCK2 frequency fixed to 1fs.

Mode	IDIF1	IDIF0	Output Format	Input Format	LRCK	BICK
0	0	0	24bit, MSB justified	16bit, LSB justified	H/L	≥ 32fs
1	0	1	24bit, MSB justified	24bit, MSB justified	H/L	≥ 48fs
2	1	0	24bit, I ² S Compatible	24bit, I ² S Compatible	L/H	≥ 48fs
3	1	1	24bit, MSB justified	24bit, LSB justified	H/L	≥ 48fs

Default

Table 9. Audio Interface Format for PORT2

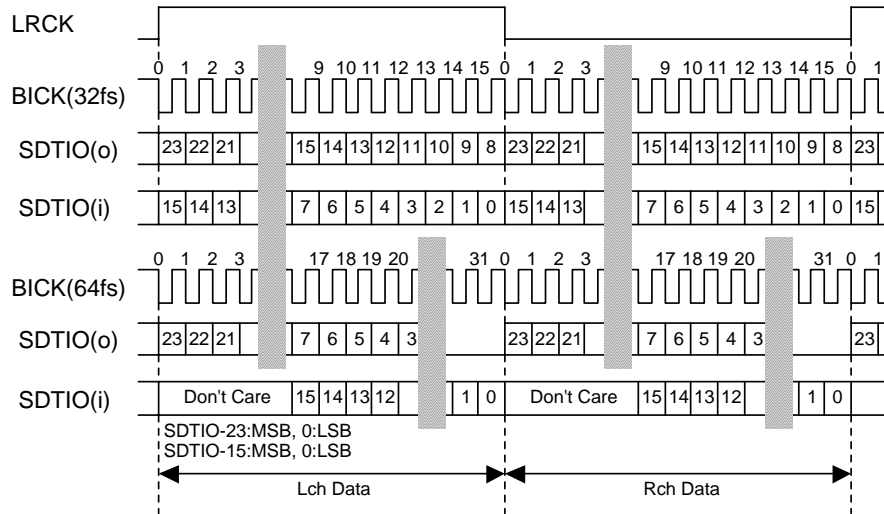

Figure 6. Mode 0 Timing

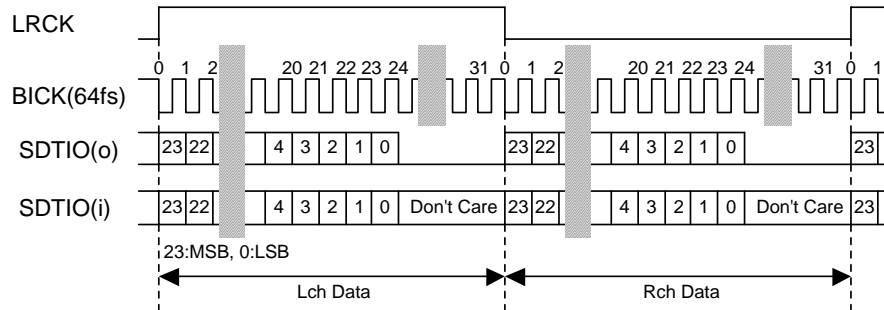

Figure 7. Mode 1 Timing

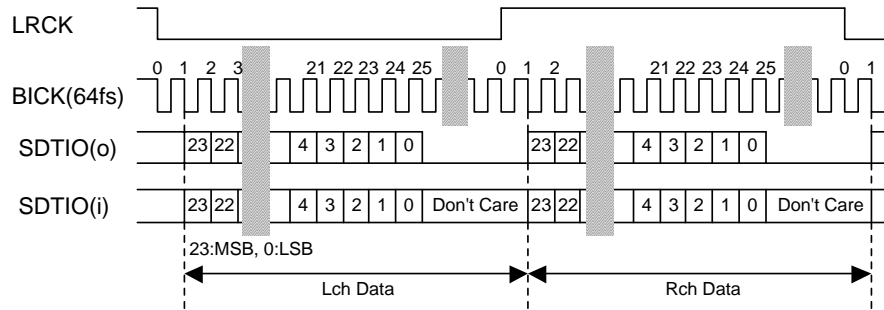

Figure 8. Mode 2 Timing

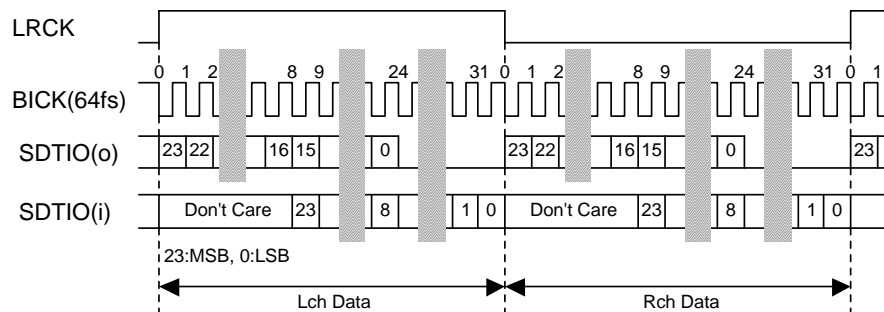

Figure 9. Mode 3 Timing

(3) PORT3

Two kinds of data formats can be chosen with the ODIF bit (Table 10). In both modes, the serial data is in MSB first, 2's compliment format. The SDTO is clocked out on the falling edge of BICK. The audio interface supports both master and slave modes. In master mode, BICK and LRCK are output with the BICK frequency fixed to 64fs and the LRCK frequency fixed to 1fs.

Mode	ODIF	Output Format	LRCK	BICK	Default
0	0	24bit, MSB justified	H/L	≥ 48fs	
1	1	24bit, I ² S Compatible	L/H	≥ 48fs	

Table 10. Audio Interface Format for PORT3

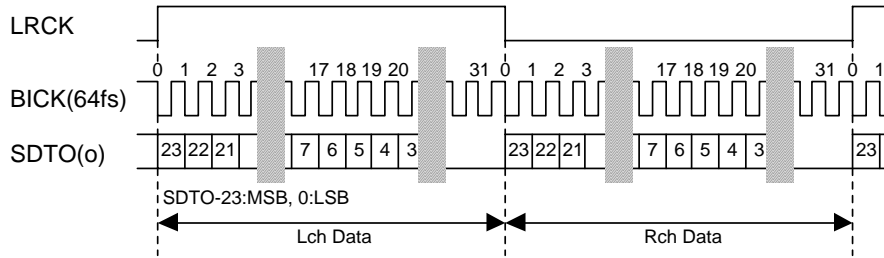

Figure 10. Mode 0 Timing

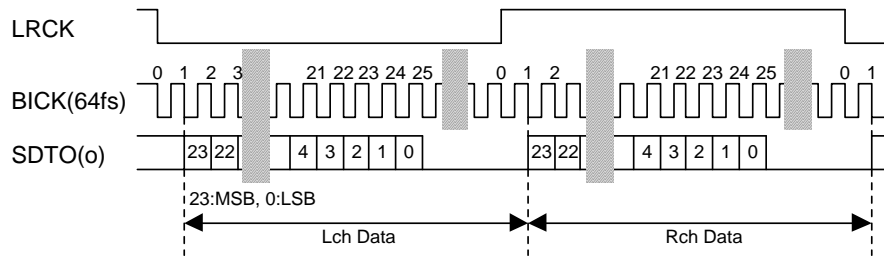

Figure 11. Mode 1 Timing

■ Soft Mute Operation

Soft mute operation is performed in the digital domain of the SRC output. Soft mute can be controlled by SMUTE bit or SMUTE pin. The SMUTE bit and SMUTE pin are ORed between pin and register. When SMUTE bit goes “1” or SMUTE pin goes “H”, the SRC output data is attenuated by $-\infty$ within 1024 LRCK cycles. When the SMUTE bit returned “0” and SMUTE pin goes “L” the mute is cancelled and the output attenuation gradually changes to 0dB during 1024 LRCK cycles. If the soft mute is cancelled before mute state after starting of the operation, the attenuation is discontinued and returned to 0dB by the same cycles. The soft mute is effective for changing the signal source.

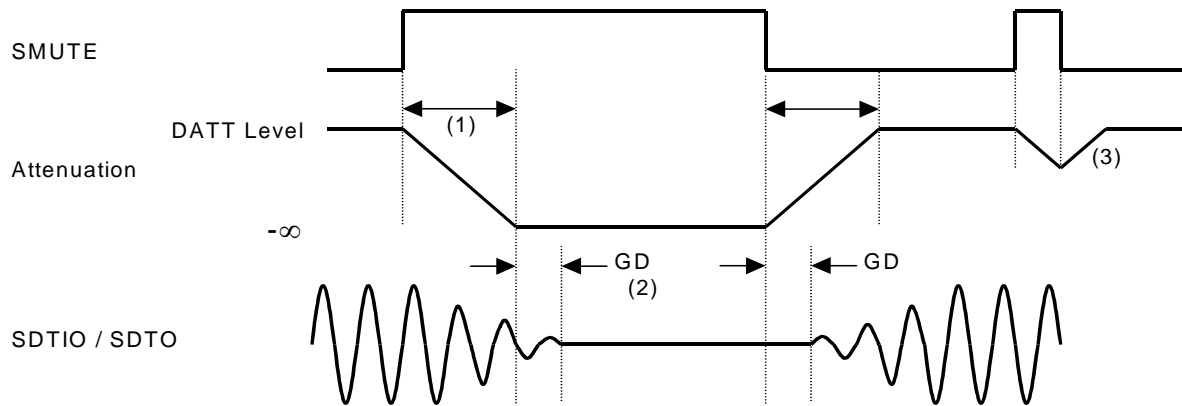

Figure 12. Soft Mute Function

- (1) The output data is attenuated by $-\infty$ during 1024 LRCK cycles ($1024/f_s$).
- (2) Digital output delay from the digital input is called the group delay (GD).
- (3) If the soft mute is cancelled before attenuating to $-\infty$ after starting the operation, the attenuation is discontinued and returned to 0dB by the same number of clock cycles.

■ De-emphasis Filter Control

The AK4122 includes the digital de-emphasis filter ($t_c=50/15\mu s$) by IIR filter corresponding to three sampling frequencies (32kHz, 44.1kHz and 48kHz).

(1) When input port is DIR

When the input port is DIR and DEAU bit = "1", the de-emphasis filter is enabled automatically by sampling frequency (FS3-0 bit) and pre-emphasis information in the channel status. DEM1-0 bits can control the de-emphasis filter when DEAU bit = "0". When the de-emphasis filter is OFF, the internal de-emphasis filter is bypassed. When PEM bit = "0", the internal de-emphasis filter is always bypassed.

PEM	FS3	FS2	FS1	FS0	Mode
1	0	0	0	0	44.1kHz
1	0	0	1	0	48kHz
1	0	0	1	1	32kHz
1	(Others)				OFF
0	x	x	x	x	OFF

Table 11. De-emphasis Auto Control (DEAU bit = "1")

PEM	DEM1	DEM0	Mode
1	0	0	44.1kHz
1	0	1	OFF
1	1	0	48kHz
1	1	1	32kHz

Default

Table 12. De-emphasis Manual Control (DEAU bit = "0")

(2) When input port is PORT1 or PORT2

When PORT1 or PORT2 is selected as input port, DEM1-0 bits can control the de-emphasis filter even if DEAU bit = "0" or DEAU bit = "1". In this case, the de-emphasis filter cannot enable automatically. When the de-emphasis filter is OFF, the internal de-emphasis filter is bypassed.

DEM1	DEM0	Mode
0	0	44.1kHz
0	1	OFF
1	0	48kHz
1	1	32kHz

Default

Table 13. De-emphasis Manual Control

■ System Reset and Power-Down

The AK4122 has a full power-down mode for all circuits that is activated by the PDN pin, and a partial power-down mode activated by the PWN bit. The AK4122 should be reset once at power-up by bringing PDN pin = "L".

PDN pin:

All analog and digital circuits are placed in power-down and reset modes by bringing PDN pin = "L". All the registers are initialized and clocks are stopped. Read/Write operations to the registers are disabled.

PWN bit (Address 00H; D0):

Unlike the PDN pin operation described above, internal registers and mode settings are not initialized. Read/Write operations to the registers are enabled.

■ System Reset

Bringing the PDN pin = "L" sets the AK4122 power-down mode and initializes the digital filter. When PDN pin = "L", the SDTO output is "L". The AK4122 should be reset once by bringing PDN pin = "L" upon power-up. The SDTO is valid from less than 100ms after the rising of PDN after clocks are supplied, and until then, outputs "L". After the rising of PDN pin, the SDTIO pin is input pin.

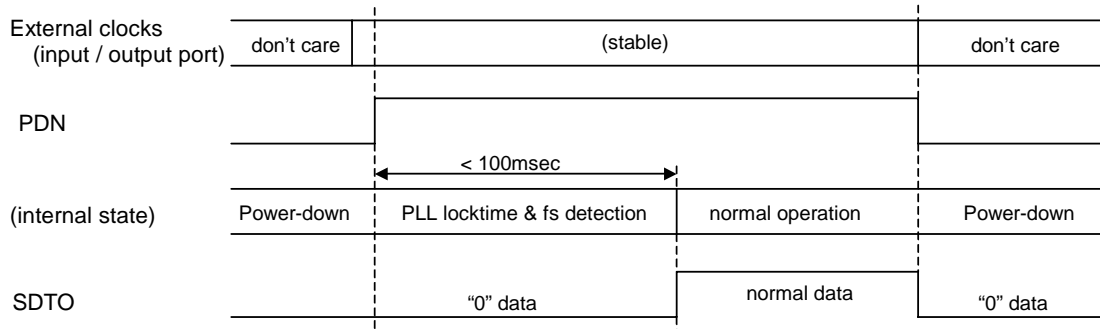

Figure 13. System Reset

■ Sequence of changing clocks

The recommended sequence of changing clocks is shown as Figure 14. The internal reset is executed when the input or the output clocks are changed. The SDTO is placed "0" during reset. Within 100ms, the SDTO outputs normal data. When the frequency transition occurs gradually without the phase change, the output data may have large distortion for several seconds. Then, to output normal data within 100ms, a reset by PDN pin = "L" or PWN bit = "0" is recommended when clocks are changed.

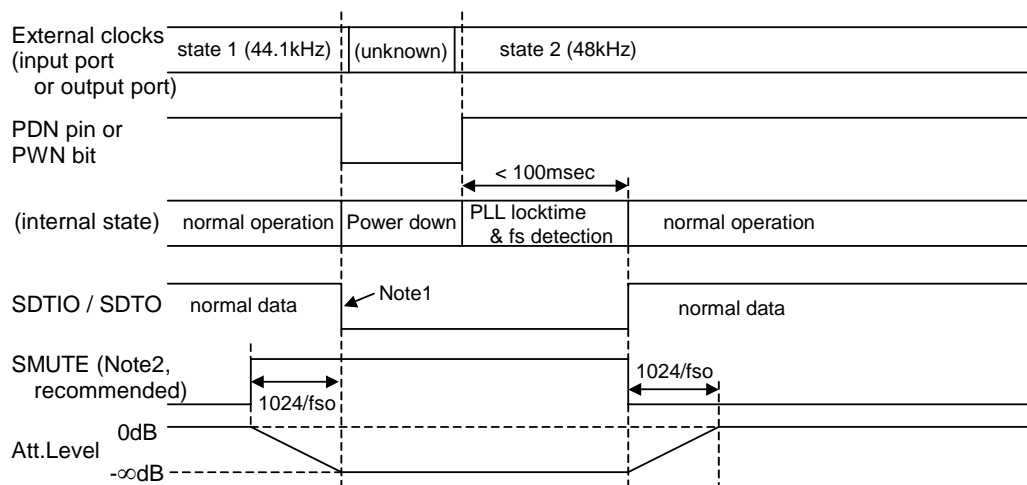

Figure 14. Sequence of changing clocks

Note 1. The data on SDTO may cause click noise. If SDTI or SDTIO is "0" from GD before PDN pin goes "L", the data on SDTO keeps "0" then no unknown data is output.

Note 2. SMUTE can remove the unknown data.

■ 96kHz Clock Recovery

The on-chip, low jitter PLL of DIR has a wide lock range of 32kHz to 96kHz and a lock time of less than 20ms. The AK4122 has a sampling frequency detect function (32kHz, 44.1kHz, 48kHz, 88.2kHz, 96kHz) that uses either clock comparison against the MCLK2 or OMCLK frequency or the channel status information. The PLL loses lock when the received sync interval is incorrect.

■ Biphase Input

Four receiver inputs (RX1-4) of DIR are available. Each input includes an amplifier for unbalance loads that can accept 200mVpp or greater signal. The IPS1-0 bits select the receiver channel (Table 14).

IPS1	IPS0	Input Data	Default
0	0	RX1	
0	1	RX2	
1	0	RX3	
1	1	RX4	

Table 14. Recovery Data Select

■ Biphase Output

The AK4122 can output the through data from the digital receiver inputs (RX1-4) to the TX pin. The OPS1-0 bits can select the source of the output from the TX pin. TX output can be stopped by TXE bit. AK4122 does not have the TX output buffer (Line Driver), the TX pin cannot drive the 75Ω coaxial cable directly.

OPS1	OPS0	Output Data	Default
0	0	RX1	
0	1	RX2	
1	0	RX3	
1	1	RX4	

Table 15. Output Data Select for TX

■ Biphase signal input circuit

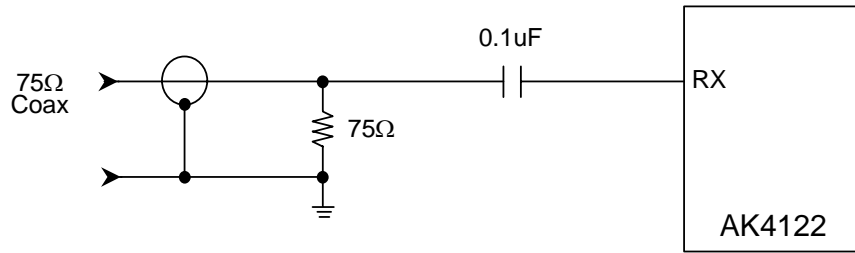

Figure 15. Consumer Input Circuit (Coaxial Input)

Note 1: Coax input only : if a coupling level to this input from the next RX input line pattern exceeds 50mV, an incorrect operation may occur. In this case, it is possible to lower the coupling level by adding this decoupling capacitor.

Note 2: Ground of the RCA connector and terminator should be connected to AVSS of the AK4122 with low impedance on PC board.

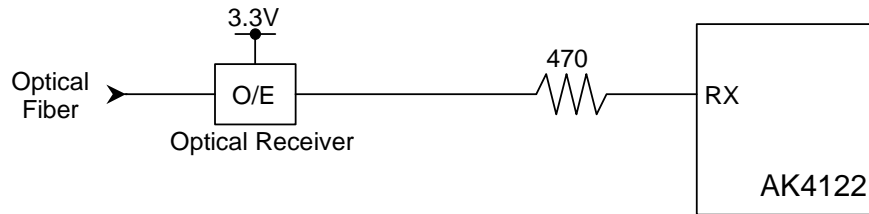

Figure 16. Consumer Input Circuit (Optical Input, Using 3.3V Optical Receiver)

When using coaxial input, the input level of the RX line is small. Care must be taken to reduce, crosstalk among RX input lines by inserting a shield pattern between them.

■ Sampling Frequency and Pre-emphasis Detection

The AK4122 has two methods for detecting the sampling frequency. The sampling frequency is detected by comparing the recovered clock to the MCLK2 or OMCLK frequency, and the detected frequency is reported on FS3-0 bits. XTL1-0 bits, ICKS1-0 bits and OCKS1-0 bits can select reference MCLK2 and OMCLK (Table 16). When XTL1-0 bits = “11”, the sampling frequency is detected by the channel status sampling frequency information. The detected frequency is reported on FS3-0 bits. The default values of FS3-0 bits are “0001”. In case of detecting the sampling frequency by MCLK when DIR is used, MCLK (MCLK2 or OMCLK) of selected output port (PORT2 or PORT3) should be input.

XTL1	XTL0	MCLK2 or OMCLK		MCLK Frequency
		ICKS1 / OCKS1	ICKS0 / OCKS0	
0	0	0	0	11.2896MHz
		0	1	22.5792MHz
		1	0	16.9344MHz
		1	1	33.8688MHz
0	1	0	0	12.288MHz
		0	1	24.576MHz
		1	0	18.432MHz
		1	1	36.864MHz
1	0	0	0	24.576MHz
		0	1	N/A
		1	0	36.864MHz
		1	1	N/A
1	1	-	-	Use channel status

Default

Table 16. Reference MCLK Frequency

Register Output				fs	Except XTL1-0 bit = “11”	XTL1-0 bit = “11”		
					Clock comparison (Note 1)	Consumer Mode (Note 2)	Professional Mode	
FS3	FS2	FS1	FS0				Byte3 Bit3,2,1,0	Byte0 Bit7,6
0	0	0	0	44.1kHz	± 3%	0000	01	0000
0	0	0	1	Reserved	-	0001	(others)	0000
0	0	1	0	48kHz	± 3%	0010	10	0000
0	0	1	1	32kHz	± 3%	0011	11	0000
1	0	0	0	88.2kHz	± 3%	(1000)	00	1010
1	0	1	0	96kHz	± 3%	(1010)	00	0010

Table 17. fs Information

Note 1. At least ±3% range is identified as the value in the Table 17. In case of an intermediate frequency of these two, FS3-0 bits indicate the nearer value. When the frequency is much larger than 96kHz or much smaller than 32kHz, FS3-0 bits may indicate “1100”, “1110” or “0001”.

Note 2. In consumer mode, Byte3 Bit3-0 are copied to FS3-0.

The pre-emphasis information is detected and reported on the PEM bit. This information is extracted from channel 1 by default (CS12 bit = “0”). It can be switched to channel 2 by changing the CS12 bit in the control register.

PEM bit	Pre-emphasis	Consumer mode	Professional mode
		Byte0 Bit3,4,5	Byte0 Bit2,3,4
0	OFF	≠ 0X100	≠ 100
1	ON	0X100	100

Table 18. PEM Information

■ Interrupt Handling for DIR

There are nine events that cause the INT2-0 pins to go “H”.

1. UNLCK: PLL unlock state detection
“1” when the PLL loses lock. The AK4122 loses lock when the distance between two preambles is not correct or when those preambles are not correct.
2. PAR: Parity error or biphase coding error detection
“1” when parity error or biphase coding error is detected, updated every sub-frame cycle.
3. AUTO: Non-PCM or DTS-CD Bit Stream detection
The OR function of NPCM and DTSCD bits is output to the AUTO bit.
4. V: Validity flag detection
“1” when validity flag is detected. Updated every sub-frame cycle.
5. AUDN: Non-audio detection
“1” when the “AUDN” bit in recovered channel status indicates “1”. Updated every block cycle.
6. STC: Sampling frequency or pre-emphasis information change detection
“1” when FS3-0 or PEM bit changes. Reading 07H register resets it.
7. QINT: U bit (Q-subcode) sync flag
“1” when the Q-subcode differs from old one, and stays “1” until this register is read. Updated every sync code cycle for Q-subcode. Reading 07H register resets it.
8. CINT: Channel status sync flag
“1” when received C bits differ from old ones, and stays “1” until this register is read. Updated every block cycle. Reading 07H register resets it.
9. DAT: DAT Start ID detection
When the category code shows DAT, “1” when the Start ID of DAT is detected. Reading 08H register resets it.

INT1-0 pins output an OR’ed signal based on the above nine interrupt events. When masked, the interrupt event does not affect the operation of the INT1-0 pins (the masks do not affect the registers (UNLCK, PAR, etc.) themselves). Once INT0 pin goes to “H”, it maintains “H” for 1024 cycles (this value can be changed by the EFH1-0 bits) after all events not masked by mask bits are cleared. INT1 pin immediately goes to “L” when those events are cleared.

INT2 pin output a state change on the above 1 ~ 5 and an OR’ed signal based on the above 6 ~ 9. It stays “H” until 07H and 08H registers are read. Mask bits are shared with INT0.

UNLCK, AUTO, V and AUDN bits indicate the interrupt status events above in real time. Once PAR, STC, QINT or CINT and DAT bit goes to “1”, it stays “1” until the register is read.

When the AK4122 loses lock, the channel status bits are initialized. In this initial state, INT0 and INT2 outputs the OR’ed signal between UNLCK and PAR bits. INT1 outputs the OR’ed signal to AUTO, V and AUDN. INT2-0 pins are “L” when the DIR is not selected.

When DIR is used as input port and the PLL loses lock (unlock state), the output data is muted automatically. When AMUTE bit = “1”, SDTIO and SDTO are muted automatically when the AK4122 detects unlock, Non-Audio or Non-PCM/DTS-CD. After the interrupt events are cleared, mute is cancelled automatically. When AMUTE bit = “0”, SDTIO and SDTO outputs “L” when the PLL loses lock (unlock state), and outputs data when other errors (PAR, AUTO etc.).

(1) UNLCK, PAR, AUTO, V and AUDN bits

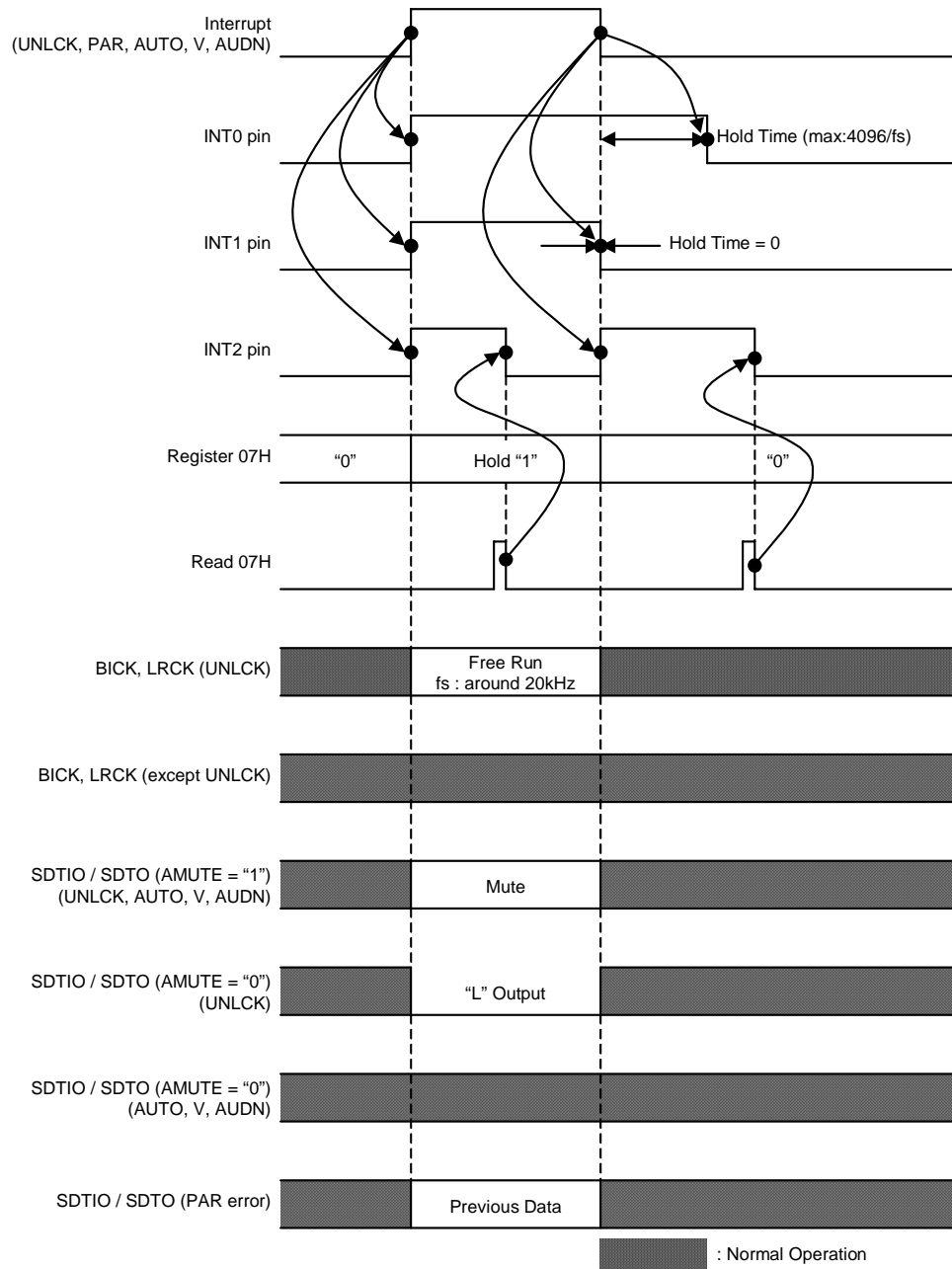

Figure 17. INT2-0 Timing (UNLCK, PAR, AUTO, V, AUDN bits)

(2) STC, CINT and QINT bits

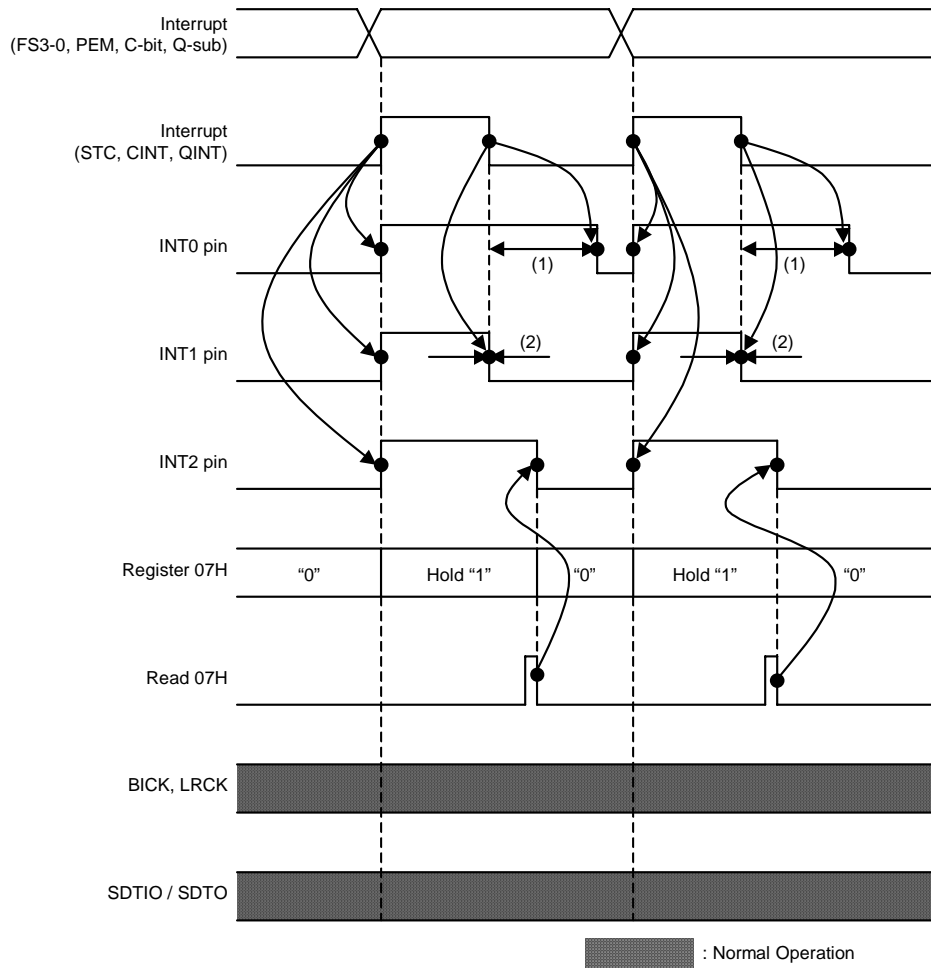

Figure 18. INT2-0 Timing (STC, CINT, QINT bits)

- (1) Hold Time : max. 4096/fs
- (2) Hold Time = 0

(3) DAT bit

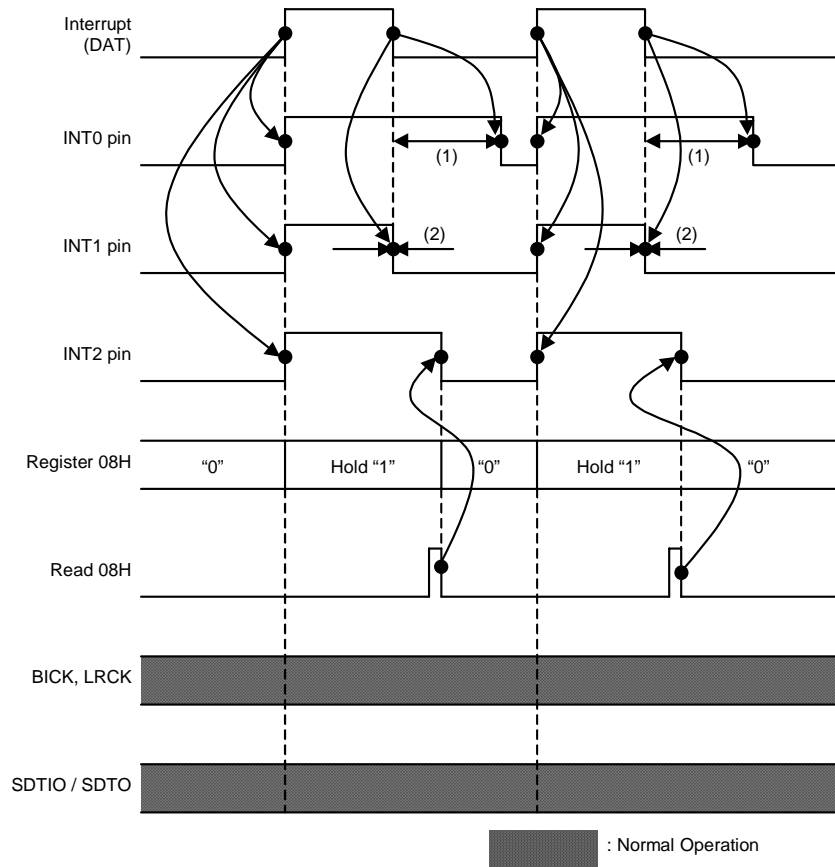

Figure 19. INT2-0 Timing (DAT bit)

- (1) Hold Time : max. $4096/f_s$
- (2) Hold Time = 0

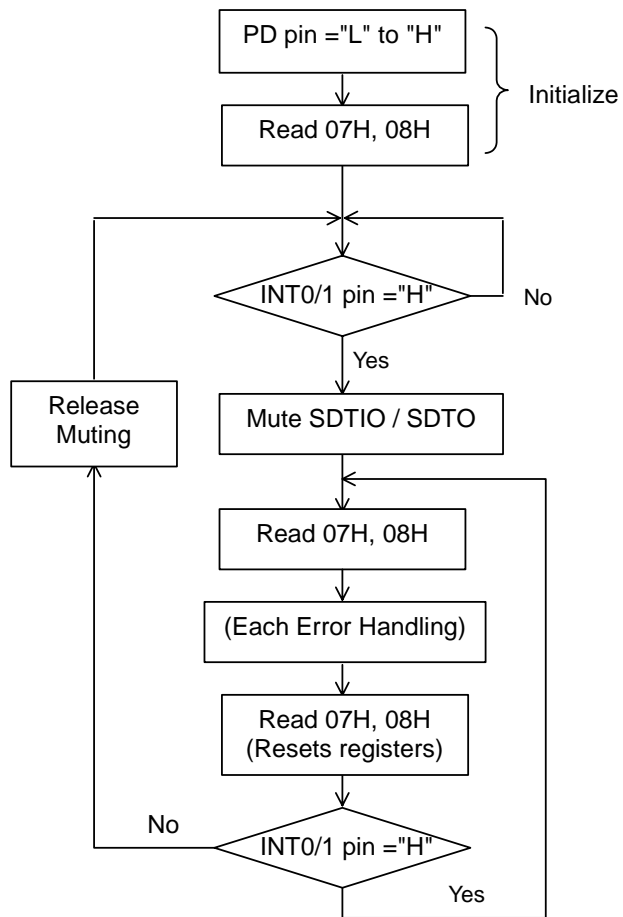

Figure 20. Interrupt Handling Sequence Example 1

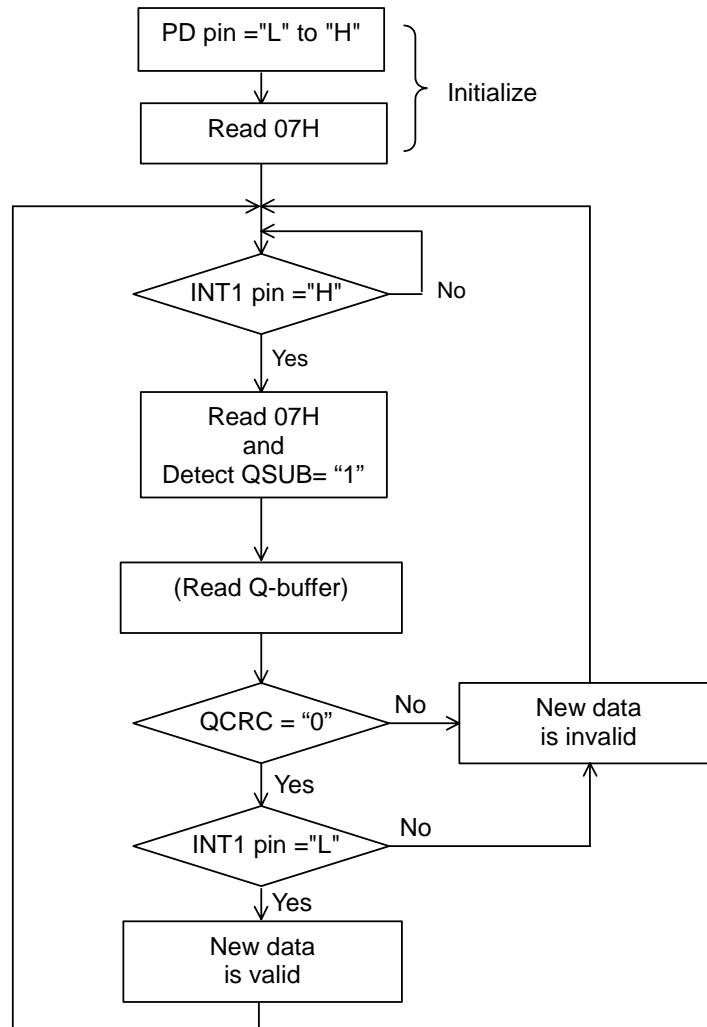

Figure 21. Interrupt Handling Sequence Example 2

■ Q-subcode buffers

The DIR of the AK4122 has a Q-subcode buffer for CD application. The AK4122 takes Q-subcode into registers under the following conditions:

- 1) The sync word (S0, S1) consists of at least 16 “0”s.
- 2) The start bit is “1”.
- 3) Those 7-bits Q-W follows to the start bit.
- 4) The distance between two start bits is 8-16 bits.

The QINT bit in the control register goes “1” when the new Q-subcode differs from old one, and goes “0” when QINT bit is read.

	1	2	3	4	5	6	7	8	*
S0	0	0	0	0	0	0	0	0	0...
S1	0	0	0	0	0	0	0	0	0...
S2	1	Q2	R2	S2	T2	U2	V2	W2	0...
S3	1	Q3	R3	S3	T3	U3	V3	W3	0...
:	:	:	:	:	:	:	:	:	:
S97	1	Q97	R97	S97	T97	U97	V97	W97	0...
S0	0	0	0	0	0	0	0	0	0...
S1	0	0	0	0	0	0	0	0	0...
S2	1	Q2	R2	S2	T2	U2	V2	W2	0...
S3	1	Q3	R3	S3	T3	U3	V3	W3	0...
:	:	:	:	:	:	:	:	:	:

↑
Q

(*) number of “0” : min=0; max=8.

Figure 22. Configuration of U-bit(CD)

Q2	Q3	Q4	Q5	Q6	Q7	Q8	Q9	Q10	Q11	Q12	Q13	Q14	Q15	Q16	Q17	Q18	Q19	Q20	Q21	Q22	Q23	Q24	Q25
CTRL				ADRS				TRACK NUMBER								INDEX							
Q26	Q27	Q28	Q29	Q30	Q31	Q32	Q33	Q34	Q35	Q36	Q37	Q38	Q39	Q40	Q41	Q42	Q43	Q44	Q45	Q46	Q47	Q48	Q49
MINUTE							SECOND							FRAME									
Q50	Q51	Q52	Q53	Q54	Q55	Q56	Q57	Q58	Q59	Q60	Q61	Q62	Q63	Q64	Q65	Q66	Q67	Q68	Q69	Q70	Q71	Q72	Q73
ZERO							ABSOLUTE MINUTE							ABSOLUTE SECOND									
Q74	Q75	Q76	Q77	Q78	Q79	Q80	Q81	Q82	Q83	Q84	Q85	Q86	Q87	Q88	Q89	Q90	Q91	Q92	Q93	Q94	Q95	Q96	Q97
ABSOLUTE FRAME								CRC $G(x)=x^{16}+x^{12}+x^5+1$															

Figure 23. Q-subcode

Addr	Register Name	D7	D6	D5	D4	D3	D2	D1	D0
13H	Q-subcode Address / Control	Q9	Q8	Q3	Q2
14H	Q-subcode Track	Q17	Q16	Q11	Q10
15H	Q-subcode Index
16H	Q-subcode Minute
17H	Q-subcode Second
18H	Q-subcode Frame
19H	Q-subcode Zero
1AH	Q-subcode ABS Minute
1BH	Q-subcode ABS Second
1CH	Q-subcode ABS Frame	Q81	Q80	Q75	Q74

Figure 24. Q-subcode register map

■ Non-PCM (AC-3, MPEG, etc.) and DTS-CD Bitstream Detection

The DIR of the AK4122 has a Non-PCM steam auto-detection function. When the 32-bit mode Non-PCM preamble based on Dolby “AC-3 Data Stream in IEC60958 Interface” is detected, the NPCM bit goes to “1”. The 96-bit sync code consists of 0x0000, 0x0000, 0x0000, 0x0000, 0xF872 and 0x4E1F. Detection of this pattern will set the NPCM to “1”. Once the NPCM is set to “1”, it will remain “1” until 4096 frames pass through the chip without an additional sync pattern being detected (Timing diagram: Figure 27 and Figure 28). When those preambles are detected, the burst preambles Pc and Pd (Pc: burst information, Pd: length code; Refer to Table 22, 23) that follow those sync codes are stored to registers. The AK4122 also has a DTS-CD bitstream auto-detection function. When AK4122 detects DTS-CD bitstream, the DTSCD bit goes to “1”. If the next sync code does not occur within 4096 frames, the DTSCD bit goes to “0” until either the AK4122 detects the stream again. OR’ed value of the NPCM and DTSCD bits are output to the AUTO bit. The AK4122 detects 14bit sync word and 16bit sync word of a DTS-CD bitstream, the detection function can be set ON/OFF by DTS14 and DTS16 bit.

■ Serial Control Interface

The internal registers may be either written or read by the 4-wire μP interface pins: CSN, CCLK, CDTI & CDTO. The data on this interface consists of Chip address (2bits, C1/0 are fixed to “00”), Read/Write (1bit), Register address (MSB first, 5bits) and Control data (MSB first, 8bits). Address and data is clocked in on the rising edge of CCLK and data is clocked out on the falling edge. For write operations, data is latched after the 16th rising edge of CCLK, after a high-to-low transition of CSN. For read operations, the CDTO output goes to high impedance after a low-to-high transition of CSN. The maximum speed of CCLK is 5MHz. The chip address is fixed to “00”. The access to the chip address except for “00” is invalid. PDN pin = “L” resets the registers to their default values. Read/Write can be access without MCLK, BICK and , LRCK.

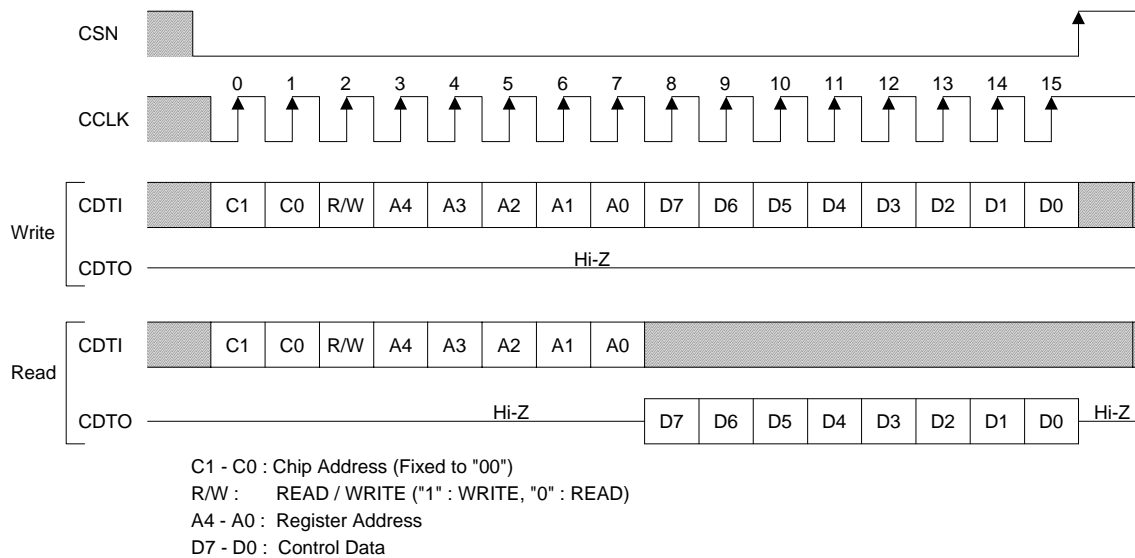

Figure 25. Control I/F Timing

■ Register Map

Addr	Register Name	D7	D6	D5	D4	D3	D2	D1	D0
00H	PDN & Mode Control	XTL1	XTL0	TXE	SMUTE	DEAU	DEM1	DEM0	PWN
01H	Selector & Clock Control	BYPSS	OSEL	ISEL1	ISEL0	ICKS1	ICKS0	OCSK1	OCSK0
02H	Audio Interface Format	0	0	0	ODIF	IDIF1	IDIF0	DIF1	DIF0
03H	DIR Control	CS12	AMUTE	EFH1	EFH0	IPS1	IPS0	OPS1	OPS0
04H	INT0 Mask	MULK0	MPAR0	MAUT0	MV0	MAUD0	MSTC0	MCIT0	MQIT0
05H	INT1 Mask	MULK1	MPAR1	MAUT1	MV1	MAUD1	MSTC1	MCIT1	MQIT1
06H	DAT Mask & DTS Detect	0	0	0	0	DTS16	DTS14	MDAT1	MDAT0
07H	Receiver Status 0	UNLCK	PAR	AUTO	V	AUDN	STC	CINT	QINT
08H	Receiver Status 1	DAT	DTSCD	NPCM	PEM	FS3	FS2	FS1	FS0
09H	Receiver Status 2	0	0	0	0	0	0	CCRC	QCRC
0AH	RX Channel Status Byte 0	CR7	CR6	CR5	CR4	CR3	CR2	CR1	CR0
0BH	RX Channel Status Byte 1	CR15	CR14	CR13	CR12	CR11	CR10	CR9	CR8
0CH	RX Channel Status Byte 2	CR23	CR22	CR21	CR20	CR19	CR18	CR17	CR16
0DH	RX Channel Status Byte 3	CR31	CR30	CR29	CR28	CR27	CR26	CR25	CR24
0EH	RX Channel Status Byte 4	CR39	CR38	CR37	CR36	CR35	CR34	CR33	CR32
0FH	Burst Preamble Pc Byte 0	PC7	PC6	PC5	PC4	PC3	PC2	PC1	PC0
10H	Burst Preamble Pc Byte 1	PC15	PC14	PC13	PC12	PC11	PC10	PC9	PC8
11H	Burst Preamble Pd Byte 0	PD7	PD6	PD5	PD4	PD3	PD2	PD1	PD0
12H	Burst Preamble Pd Byte 1	PD15	PD14	PD13	PD12	PD11	PD10	PD9	PD8
13H	Q-subcode Address / Control	Q9	Q8	Q7	Q6	Q5	Q4	Q3	Q2
14H	Q-subcode Track	Q17	Q16	Q15	Q14	Q13	Q12	Q11	Q10
15H	Q-subcode Index	Q25	Q24	Q23	Q22	Q21	Q20	Q19	Q18
16H	Q-subcode Minute	Q33	Q32	Q31	Q30	Q29	Q28	Q27	Q26
17H	Q-subcode Second	Q41	Q40	Q39	Q38	Q37	Q36	Q35	Q34
18H	Q-subcode Frame	Q49	Q48	Q47	Q46	Q45	Q44	Q43	Q42
19H	Q-subcode Zero	Q57	Q56	Q55	Q54	Q53	Q52	Q51	Q50
1AH	Q-subcode ABS Minute	Q65	Q64	Q63	Q62	Q61	Q60	Q59	Q58
1BH	Q-subcode ABS Second	Q73	Q72	Q71	Q70	Q69	Q68	Q67	Q66
1CH	Q-subcode ABS Frame	Q81	Q80	Q79	Q78	Q77	Q76	Q75	Q74

PDN pin = "L" resets the registers to their default values.

When PORT1 or PORT2 are selected as input port, the status registers (07H ~ 1CH) are initialized.

Note. Unused bits must contain a "0" value.

Note. For addresses from 1DH ~ 1FH, data must not be written.

■ Register Definitions

Addr	Register Name	D7	D6	D5	D4	D3	D2	D1	D0
00H	PDN & Mode Control	XTL1	XTL0	TXE	SMUTE	DEAU	DEM1	DEM0	PWN
	R/W	R/W	R/W	R/W	R/W	R/W	R/W	R/W	R/W
	Default	1	1	1	0	0	0	1	1

PWN: Power Down Control

0 : Power down

1 : Normal operation (Default)

“0” powers down all sections. The contents of all register are not initialized and enabled to write to the registers. The internal registers (00H ~ 06H) are not initialized, however, the status registers (07H ~ 1CH) are initialized. Read/Write operations to the registers are enabled.

DEM1-0: De-emphasis Control (Table 12, 13)

Initial values are “01”.

DEAU: De-emphasis Auto Control

0 : Disable (Default)

1 : Enable

When DEAU bit = “1”, the de-emphasis filter is enabled automatically by sampling frequency and pre-emphasis information in the channel status.

SMUTE: Soft Mute Control

0 : Normal operation (Default)

1 : SDTIO and SDTO soft mute

When SMUTE bit = “1”, SDTO and SDTIO outputs “L”.

TXE: TX Output enable

0 : Disable, TX outputs “L”.

1 : Enable (Default)

XTL1-0: Reference MCLK Frequency Select (Table 16)

Initial values are “11”.

Addr	Register Name	D7	D6	D5	D4	D3	D2	D1	D0
01H	Selector & Clock Control	BYPS	OSEL	ISEL1	ISEL0	ICKS1	ICKS0	OCKS1	OCKS0
	R/W	R/W	R/W	R/W	R/W	R/W	R/W	R/W	R/W
	Default	0	0	0	0	1	0	1	0

OCKS1-0: OMCLK Frequency Select for Master mode (Table 5)
Initial values are "10".

ICKS1-0: MCLK2 Frequency Select for Master mode (Table 4)
Initial values are "10".

ISEL1-0: Input Port Select
Initial values are "00".

ISEL1	ISEL0	Input PORT
0	0	PORT1
0	1	PORT2
1	0	DIR
1	1	N/A

Default

Table 19. Input PORT Select

OSEL: Output Port Select
Initial values are "0".

OSEL	Output PORT
0	PORT3
1	PORT2

Default

Table 20. Output PORT Select

BYPS: Select Bypass mode
 0 : SRC mode (Default)
 1 : Bypass mode
 When BYPS bit = "1", the AK4122 outputs the clocks (BICK, LRCK) and data that is input by input port without SRC.

Addr	Register Name	D7	D6	D5	D4	D3	D2	D1	D0
02H	Audio Interface Format	0	0	0	ODIF	IDIF1	IDIF0	DIF1	DIF0
	R/W	RD	RD	RD	R/W	R/W	R/W	R/W	R/W
	Default	0	0	0	0	0	1	0	1

DIF1-0: Audio Interface Format for PORT1 (Table 8)

Initial values are "01".

IDIF1-0: Audio Interface Format for PORT2 (Table 9)

Initial values are "01".

ODIF: Audio Interface Format for PORT3 (Table 10)

Initial values are "0".

Addr	Register Name	D7	D6	D5	D4	D3	D2	D1	D0
03H	DIR Control	CS12	AMUTE	EFH1	EFH0	IPS1	IPS0	OPS1	OPS0
	R/W	R/W	R/W	R/W	R/W	R/W	R/W	R/W	R/W
	Default	0	1	0	1	0	0	0	0

OPS1-0: Output Through Data Select for TX (Table 15)

Initial values are "00".

IPS1-0: Input Recovery Data Select (Table 14)

Initial values are "00".

EFH1-0: Interrupt 0 pin Hold Count Select

Initial values are "01".

LRCK of Table 21 is DIR's LRCK, the hold time scales with 1/fs.

EFH1	EFH0	Hold Count
0	0	512LRCK
0	1	1024LRCK
1	0	2048LRCK
1	1	4096LRCK

Default

Table 21. Hold count select

AMUTE: Auto Mute Control

0 : Normal operation

1 : Auto Mute (Default)

When AMUTE bit = "1", SDTIO and SDTO are muted automatically when the AK4122 detects unlock, Non-Audio or Non-PCM/DTS-CD.

CS12: Channel Status select

0 : Channel 1 (Default)

1 : Channel 2

This bit selects that channel status is used to derive C-bit buffers, AUDN, PEM, FS3-0, Pc, Pd and CRC.

Addr	Register Name	D7	D6	D5	D4	D3	D2	D1	D0
04H	INT0 Mask	MULK0	MPAR0	MAUT0	MV0	MAUD0	MSTC0	MCIT0	MQIT0
	R/W	R/W	R/W	R/W	R/W	R/W	R/W	R/W	R/W
	Default	0	0	1	1	1	1	1	1

MQIT0: Mask enable for QINT bit
 0 : Mask disable
 1 : Mask enable

MCIT0: Mask enable for CINT bit
 0 : Mask disable
 1 : Mask enable

MSTC0: Mask enable for STC bit
 0 : Mask disable
 1 : Mask enable

MAUD0: Mask enable for AUDN bit
 0 : Mask disable
 1 : Mask enable

MV0: Mask enable for V bit
 0 : Mask disable
 1 : Mask enable

MAUT0: Mask enable for AUTO bit
 0 : Mask disable
 1 : Mask enable

MPAR0: Mask enable for PAR bit
 0 : Mask disable
 1 : Mask enable

MULK0: Mask enable for UNLCK bit
 0 : Mask disable
 1 : Mask enable

The factor which mask bit is set to "0" affects INT0 and INT2 pins operation.

Addr	Register Name	D7	D6	D5	D4	D3	D2	D1	D0
05H	INT1 Mask	MULK1	MPAR1	MAUT1	MV1	MAUD1	MSTC1	MCIT1	MQIT1
	R/W	R/W	R/W	R/W	R/W	R/W	R/W	R/W	R/W
	Default	1	1	0	0	0	1	1	1

MQIT1: Mask enable for QINT bit
 0 : Mask disable
 1 : Mask enable

MCIT1: Mask enable for CINT bit
 0 : Mask disable
 1 : Mask enable

MSTC1: Mask enable for STC bit
 0 : Mask disable
 1 : Mask enable

MAUD1: Mask enable for AUDN bit
 0 : Mask disable
 1 : Mask enable

MV1: Mask enable for V bit
 0 : Mask disable
 1 : Mask enable

MAUT1: Mask enable for AUTO bit
 0 : Mask disable
 1 : Mask enable

MPAR1: Mask enable for PAR bit
 0 : Mask disable
 1 : Mask enable

MULK1: Mask enable for UNLCK bit
 0 : Mask disable
 1 : Mask enable

The factor which mask bit is set to "0" affects INT1 pin operation.

Addr	Register Name	D7	D6	D5	D4	D3	D2	D1	D0
06H	DAT Mask & DTS Detect	0	0	0	0	DTS16	DTS14	MDAT1	MDAT0
	R/W	RD	RD	RD	RD	R/W	R/W	R/W	R/W
	Default	0	0	0	0	1	1	1	1

MDAT0: Mask enable for DAT bit
 0 : Mask disable
 1 : Mask enable

The factor which mask bit is set to "0" affects INT0 and INT2 pins operation.

MDAT1: Mask enable for DAT bit
 0 : Mask disable
 1 : Mask enable

The factor which mask bit is set to "0" affects INT1 pin operation.

DTS14: DTS-CD 14bit Sync Word Detect
 0 : No detect
 1 : Detect (Default)

DTS16: DST-CD 16bit Sync Word Detect
 0 : No detect
 1 : Detect (Default)

Addr	Register Name	D7	D6	D5	D4	D3	D2	D1	D0
07H	Receiver Status 0	UNLCK	PAR	AUTO	V	AUDN	STC	CINT	QINT
	R/W	RD	RD	RD	RD	RD	RD	RD	RD
	Default	0	0	0	0	0	0	0	0

QINT: Q-subcode Buffer Interrupt

0 : No change

1 : Changed

This bit goes to "1" when Q-subcode stored in register addresses 13H to 1CH is updated.

CINT: Channel Status Buffer Interrupt

0 : No change

1 : Changed

This bit goes to "1" when C-bit stored in register addresses 0AH to 0EH changes.

STC: Sampling Frequency or Pre-emphasis Information Change Detection

0 : No detect

1 : Detect

This bit goes to "1" when either the FS3-0 or PEM bit changes.

AUDN: Audio Bit Output

0 : Audio

1 : Non audio

This bit is made by encoding channel status bits.

V: Validity Bit

0 : Valid

1 : Invalid

AUTO: Non-PCM or DTS-CD Bit Steam Auto Detection

0 : No detect

1 : Detect

This bit outputs the OR'ed value of NPCM and DTSCD bits.

PAR: Parity Error or Bi-phase Error Status

0 : No error

1 : Error

This bit goes to "1" if a parity error or biphase error is detected in the sub-frame.

UNLCK: PLL Lock Status

0 : Lock

1 : Unlock

QINT, CINT and STC bits are initialized when 07H is read.

Addr	Register Name	D7	D6	D5	D4	D3	D2	D1	D0
08H	Receiver Status 1	DAT	DTSCD	NPCM	PEM	FS3	FS2	FS1	FS0
	R/W	RD	RD	RD	RD	RD	RD	RD	RD
	Default	0	0	0	0	0	0	0	1

FS3-0: Sampling Frequency Detection (Table 17)

PEM: Pre-emphasis Detect (Table 18)

0 : OFF

1 : ON

This bit is made by encoding the channel status bits.

NPCM: Non-PCM Bit Stream Auto Detection

0 : No detect

1 : Detect

DTSCD: DTS-CD Bit Stream Auto Detect

0 : No detect

1 : Detect

DAT: DAT Start ID Detect

0 : No detect

1 : Detect

When the category code shows DAT, "1" when the Start ID of DAT is detected. Reading 08H register resets it.

DAT bit is initialized when 08H is read.

Addr	Register Name	D7	D6	D5	D4	D3	D2	D1	D0
09H	Receiver Status 2	0	0	0	0	0	0	CCRC	QCRC
	R/W	RD	RD	RD	RD	RD	RD	RD	RD
	Default	0	0	0	0	0	0	0	0

QCRC: Cyclic Redundancy Check for Q-subcode

0 : No error

1 : Error

CCRC: Cyclic Redundancy Check for Channel Status

0 : No error

1 : Error

This bit is enabled only in professional mode and only for the channel selected by the CS12 bit.

Addr	Register Name	D7	D6	D5	D4	D3	D2	D1	D0
0AH	RX Channel Status Byte 0	CR7	CR6	CR5	CR4	CR3	CR2	CR1	CR0
0BH	RX Channel Status Byte 1	CR15	CR14	CR13	CR12	CR11	CR10	CR9	CR8
0CH	RX Channel Status Byte 2	CR23	CR22	CR21	CR20	CR19	CR18	CR17	CR16
0DH	RX Channel Status Byte 3	CR31	CR30	CR29	CR28	CR27	CR26	CR25	CR24
0EH	RX Channel Status Byte 4	CR39	CR38	CR37	CR36	CR35	CR34	CR33	CR32
R/W		RD							
Default		Not initialized							

CR39-0: Receiver Channel Status Byte 4-0
 All 40 bits are updated at the same time every block (192 frames) cycle.

Addr	Register Name	D7	D6	D5	D4	D3	D2	D1	D0
0FH	Burst Preamble Pc Byte 0	PC7	PC6	PC5	PC4	PC3	PC2	PC1	PC0
10H	Burst Preamble Pc Byte 1	PC15	PC14	PC13	PC12	PC11	PC10	PC9	PC8
11H	Burst Preamble Pd Byte 0	PD7	PD6	PD5	PD4	PD3	PD2	PD1	PD0
12H	Burst Preamble Pd Byte 1	PD15	PD14	PD13	PD12	PD11	PD10	PD9	PD8
R/W		RD							
Default		Not initialized							

PC15-0: Burst Preamble Pc Byte 0 and 1
 PD15-0: Burst Preamble Pd Byte 0 and 1

Addr	Register Name	D7	D6	D5	D4	D3	D2	D1	D0
13H	Q-subcode Address / Control	Q9	Q8	Q7	Q6	Q5	Q4	Q3	Q2
14H	Q-subcode Track	Q17	Q16	Q15	Q14	Q13	Q12	Q11	Q10
15H	Q-subcode Index	Q25	Q24	Q23	Q22	Q21	Q20	Q19	Q18
16H	Q-subcode Minute	Q33	Q32	Q31	Q30	Q29	Q28	Q27	Q26
17H	Q-subcode Second	Q41	Q40	Q39	Q38	Q37	Q36	Q35	Q34
18H	Q-subcode Frame	Q49	Q48	Q47	Q46	Q45	Q44	Q43	Q42
19H	Q-subcode Zero	Q57	Q56	Q55	Q54	Q53	Q52	Q51	Q50
1AH	Q-subcode ABS Minute	Q65	Q64	Q63	Q62	Q61	Q60	Q59	Q58
1BH	Q-subcode ABS Second	Q73	Q72	Q71	Q70	Q69	Q68	Q67	Q66
1CH	Q-subcode ABS Frame	Q81	Q80	Q79	Q78	Q77	Q76	Q75	Q74
R/W		RD							
Default		Not initialized							

Q81-2: Q-subcode
 All 80 bits are updated at the same time every sync code cycle for Q-subcode.

■ Burst Preambles in Non-PCM Bitstreams

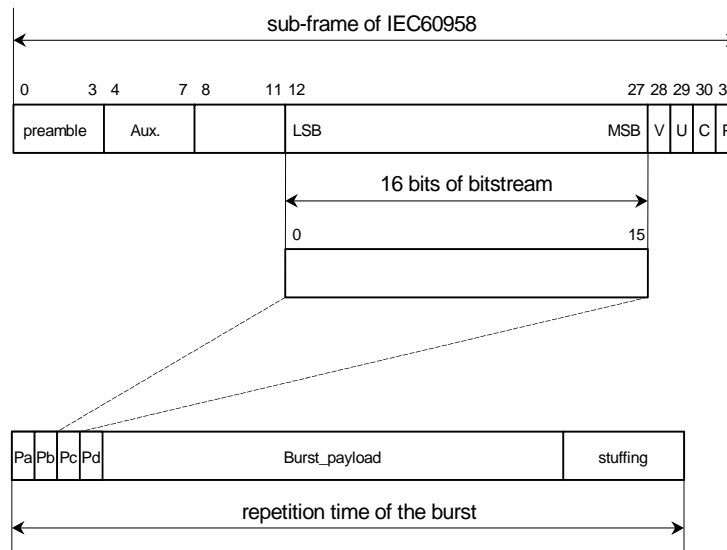

Figure 26. Data Structure of IEC60958

Preamble word	Length of field	Contents	Value
Pa	16 bits	sync word 1	0xF872
Pb	16 bits	sync word 2	0x4E1F
Pc	16 bits	Burst info	see Table 23
Pd	16 bits	Length code	numbers of bits

Table 22. Burst Preamble Word

Bits of Pc	Value	Contents	Repetition time of burst in IEC60958 frames
0-4	0	data type NULL data	≤ 4096
	1	Dolby AC-3 data	1536
	2	reserved	
	3	PAUSE	
	4	MPEG-1 Layer1 data	384
	5	MPEG-1 Layer2 or 3 data or MPEG-2 without extension	1152
	6	MPEG-2 data with extension	1152
	7	MPEG-2 AAC ADTS	1024
	8	MPEG-2, Layer1 Low sample rate	384
	9	MPEG-2, Layer2 or 3 Low sample rate	1152
	10	reserved	
	11	DTS type I	512
	12	DTS type II	1024
	13	DTS type III	2048
	14	ATRAC	512
	15	ATRAC2/3	1024
16-31	reserved		
5, 6	0	reserved, shall be set to "0"	
7	0	error-flag indicating a valid burst_payload	
	1	error-flag indicating that the burst_payload may contain errors	
8-12		data type dependent info	
13-15	0	bit stream number, shall be set to "0"	

Table 23. Field of Burst Information Pc

■ Non-PCM Bitstream Timing

(1) When Non-PCM preamble does not arrive within 4096 frames

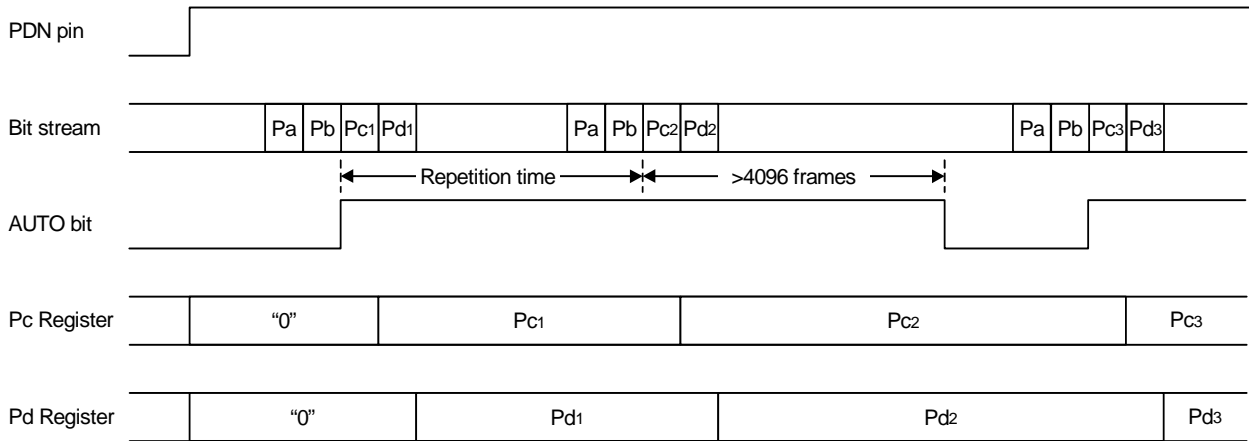

Figure 27. Timing example 1

(2) When Non-PCM bitstream stops (when MULK0=0)

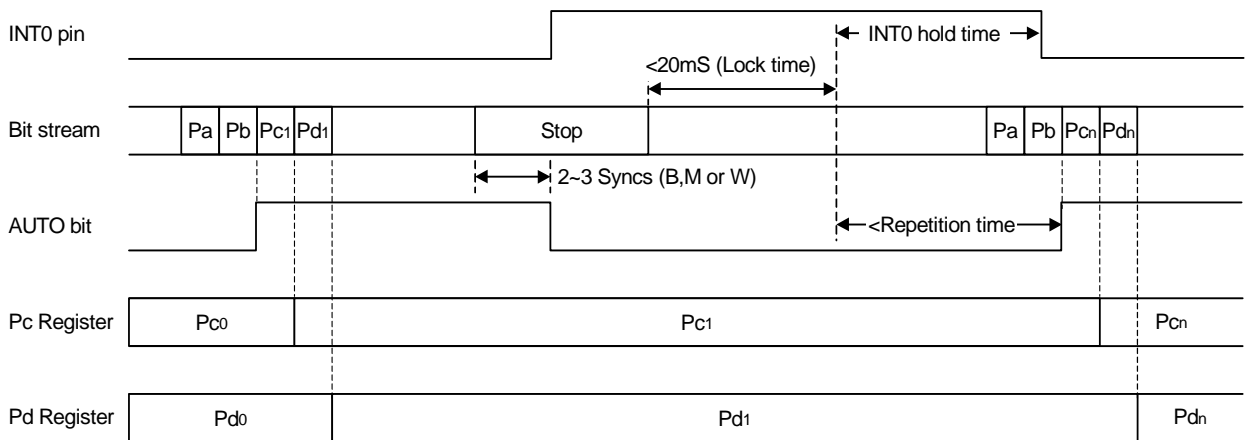
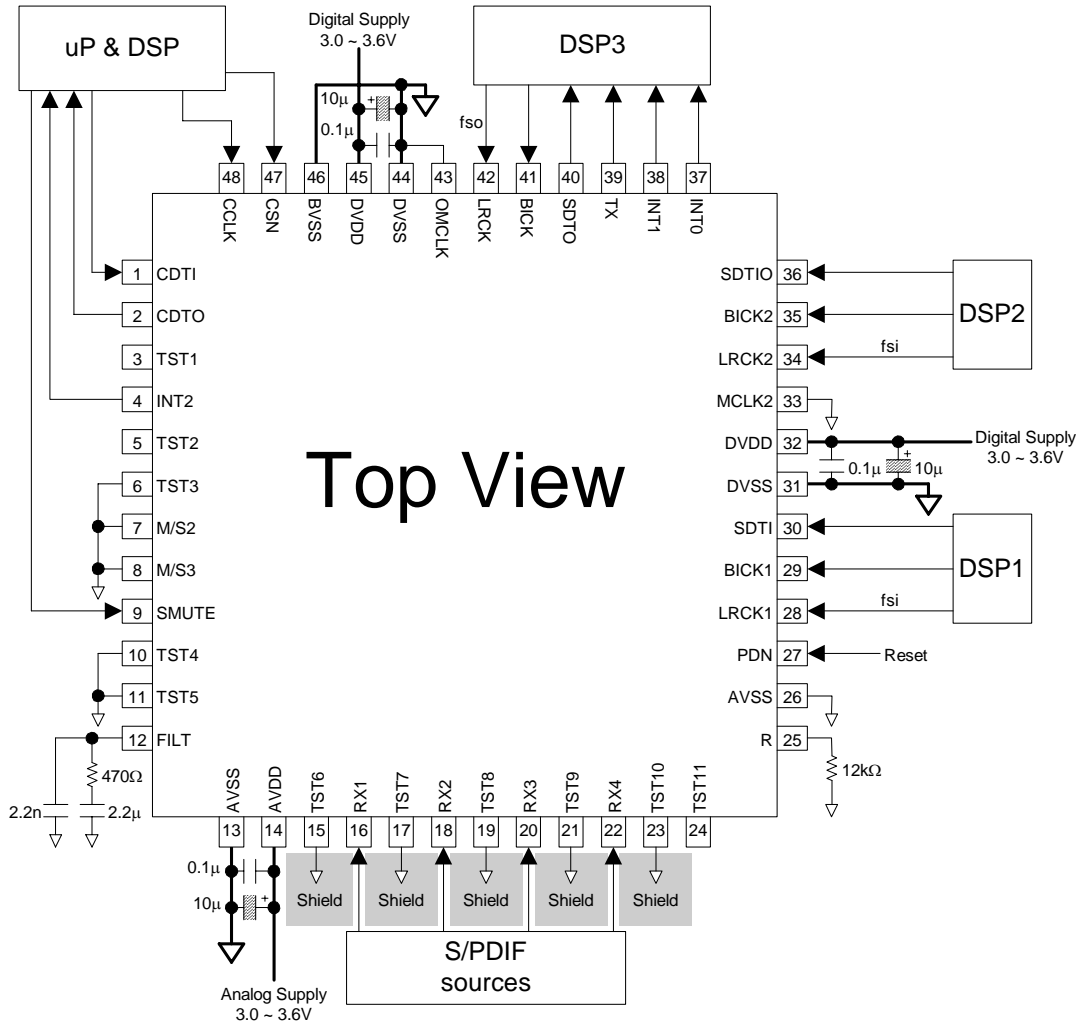

Figure 28. Timing example 2

SYSTEM DESIGN

Figure 29 shows the typical system connection diagram. An evaluation board is available which demonstrates application circuits, the optimum layout, power supply arrangements and measurement results.

- PORT2, PORT3 : Slave Mode



Note:

- AVSS, BVSS and DVSS of the AK4122 should be distributed separately from the ground of external digital devices (MPU, DSP etc.).
- All digital input pins should not be left floating.

Figure 29. Typical Connection Diagram

1. Grounding and Power Supply Decoupling

The AK4122 requires careful attention to power supply and grounding arrangements. Alternatively if AVDD and DVDD are supplied separately, the power up sequence is not critical. **AVSS, BVSS and DVSS of the AK4122 must be connected to analog ground plane.** System analog ground and digital ground should be connected together near to where the supplies are brought onto the printed circuit board. Decoupling capacitors should be as near to the AK4122 as possible, with the small value ceramic capacitor being the nearest.

2. PLL Loop-Filter

The C1 (2.2 μ F) and R1 (470 Ω) should be connected in series and attached between FILT pin and AVSS in parallel with C2 (2.2nF). Please be careful the noise onto the FILT pin.

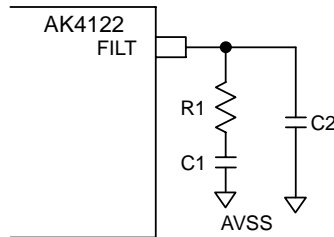

Parameter	Recommended value	Accuracy
R1	470 Ω	-5% ~ +5%
C1	2.2 μ F	-50% ~ +50%
C2	2.2nF	-50% ~ +50%

Note: The accuracy includes temperature dependence.

Figure 30. Loop Filter for SRC

The R2 (12k Ω) should be connected in series and attached between R pin and AVSS. Please be careful the noise onto the R pin.

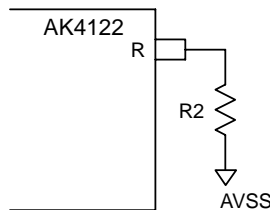

Parameter	Recommended value	Accuracy
R2	12k Ω	-5% ~ +5%

Note: The accuracy includes temperature dependence.

Figure 31. Loop Filter for DIR

3. Jitter Tolerance

Figure 32 shows the jitter tolerance to ILRCK for AK4122. The jitter frequency and the jitter amplitude shown in Figure 32 define the jitter quantity. When the jitter amplitude is 0.01U_{ipp} or less, the AK4122 operate normally regardless of the jitter frequency.

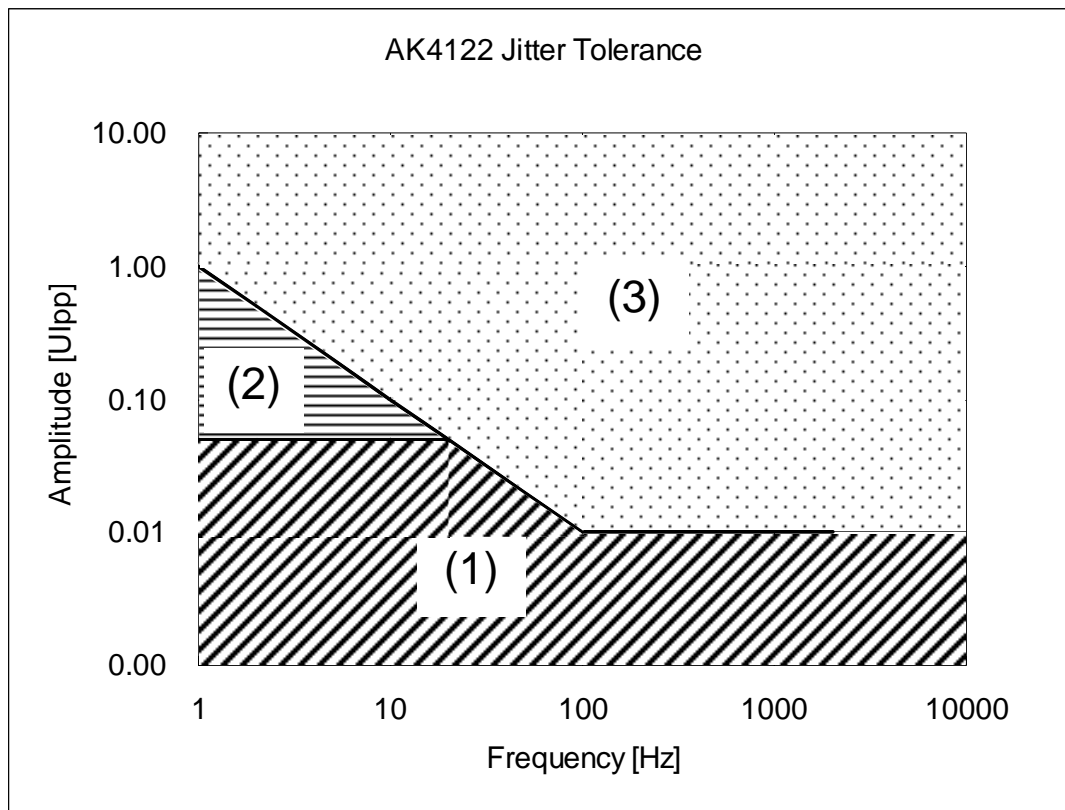

- (1) Normal operation
- (2) There is a possibility that the distortion degrades. (It may degrade up to about -50dB.)
- (3) There is a possibility that the output data is lost.

Note:

- The jitter amplitude is for ILRCK and 1UI (Unit Interval) is one cycle of ILRCK. When FSI = 48kHz, 1UI is $1/48\text{kHz} = 20.8\mu\text{s}$.

Figure 32. Jitter Tolerance

PACKAGE

48pin LQFP (Unit: mm)

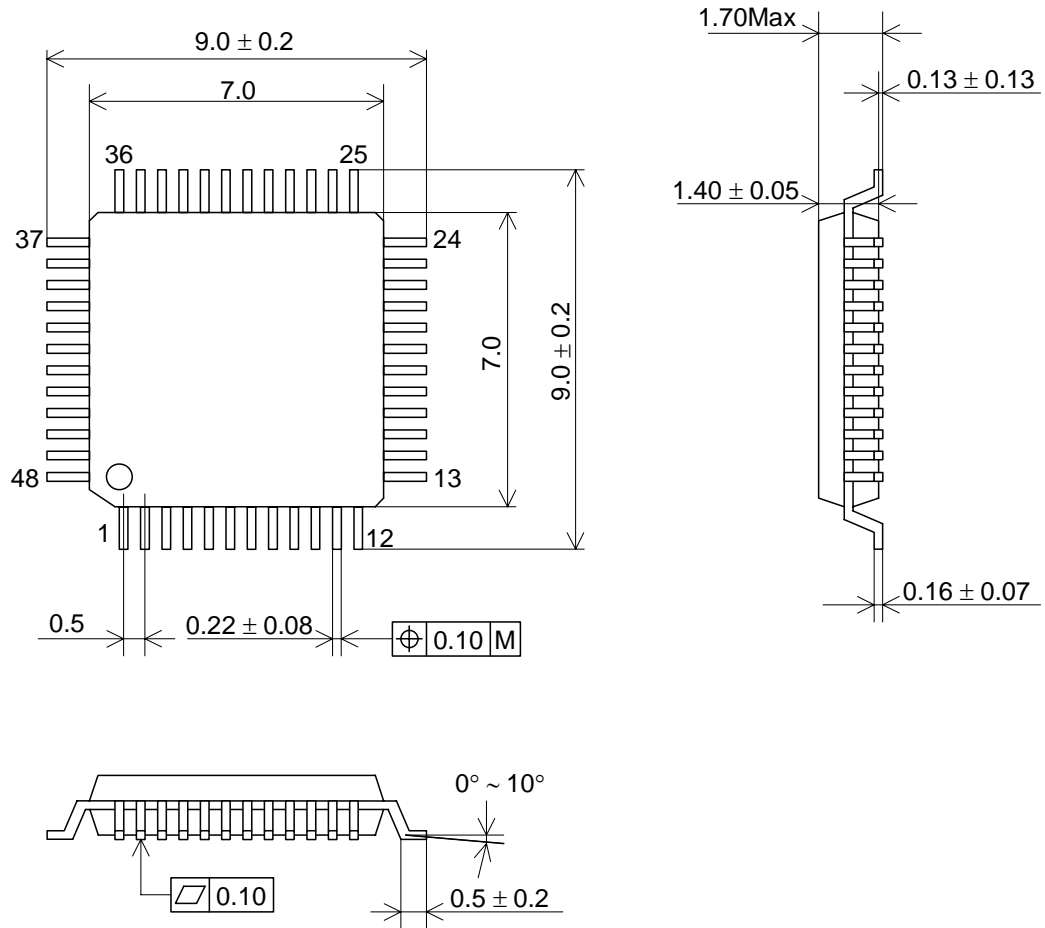

Material & Lead finish

Package molding compound:	Epoxy
Lead frame material:	Cu
Lead frame surface treatment:	Solder (Pb free) plate

MARKING

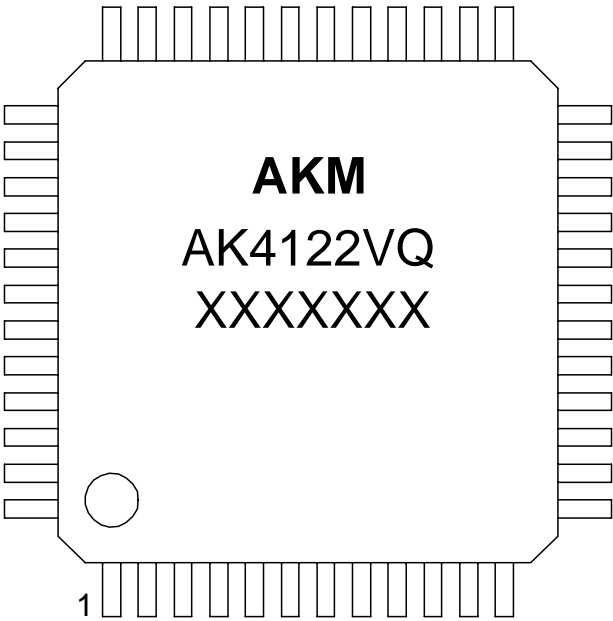

XXXXXXXX: Date code identifier

Revision History

Date (YY/MM/DD)	Revision	Reason	Page	Contents
03/10/03	00	First Edition		
04/01/27	01	Spec Change	10, 11	SWITCHING CHARACTERISTICS Audio Interface Timing BICK1/BICK2/BICK Period@Slave mode: min 160ns → 1/64/fs
04/07/23	02	Add Spec	9	Add FILTER CHARACTERISTICS
		Add Spec	16, 18	Add a sentence: “The DIF1-0 bits of the PORT1 should be set a value except “10” (I2S Compatible) when the DIR is selected as an input port.”
04/8/16	03	Add Spec	51	Add Jitter Tolerance

IMPORTANT NOTICE

- These products and their specifications are subject to change without notice. Before considering any use or application, consult the Asahi Kasei Microsystems Co., Ltd. (AKM) sales office or authorized distributor concerning their current status.
- AKM assumes no liability for infringement of any patent, intellectual property, or other right in the application or use of any information contained herein.
- Any export of these products, or devices or systems containing them, may require an export license or other official approval under the law and regulations of the country of export pertaining to customs and tariffs, currency exchange, or strategic materials.
- AKM products are neither intended nor authorized for use as critical components in any safety, life support, or other hazard related device or system, and AKM assumes no responsibility relating to any such use, except with the express written consent of the Representative Director of AKM. As used here:
 - a. A hazard related device or system is one designed or intended for life support or maintenance of safety or for applications in medicine, aerospace, nuclear energy, or other fields, in which its failure to function or perform may reasonably be expected to result in loss of life or in significant injury or damage to person or property.
 - b. A critical component is one whose failure to function or perform may reasonably be expected to result, whether directly or indirectly, in the loss of the safety or effectiveness of the device or system containing it, and which must therefore meet very high standards of performance and reliability.
- It is the responsibility of the buyer or distributor of an AKM product who distributes, disposes of, or otherwise places the product with a third party to notify that party in advance of the above content and conditions, and the buyer or distributor agrees to assume any and all responsibility and liability for and hold AKM harmless from any and all claims arising from the use of said product in the absence of such notification.