

**AsahiKASEI**  
ASAHI KASEI EMD

**AK4104**  
**192kHz 24-Bit 3.3V DIT**

#### GENERAL DESCRIPTION

The AK4104 is a digital audio interface transmitter (DIT) which supports data rate up to 192kHz sample rate operation. The AK4104 encodes and transmits audio data according to the AES3, IEC60958, S/PDIF & EIAJ CP1201 interface standards. The AK4104 accepts audio and digital data, which is then encoded. The audio serial port supports four formats.

#### FEATURES

- Sampling Rate up to 192kHz
- Support AES3, IEC60958, S/PDIF & EIAJ CP1201 Consumer Formats
- Generates Parity Bits
- 1-channel Transmission Output
- 42-bit Channel Status Buffer
- Supports Multiple Clock Frequencies: 128/192/256/384/512/768/1024/1536fs
- Supports Left/Right justified and I<sup>2</sup>S Audio Formats
- Easy to use 4 wire/3 wire Serial Host Interface
- CMOS Input Level
- Power Supply: 2.7 to 3.6V
- Small Package: 16pin TSSOP
- Temperature Range of -20 to 85 °C

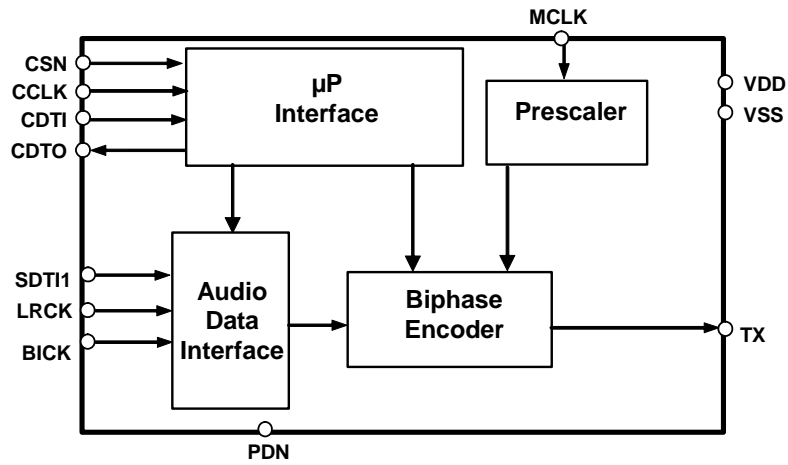


Figure 1. AK4104 Block Diagram (Mode= "0")

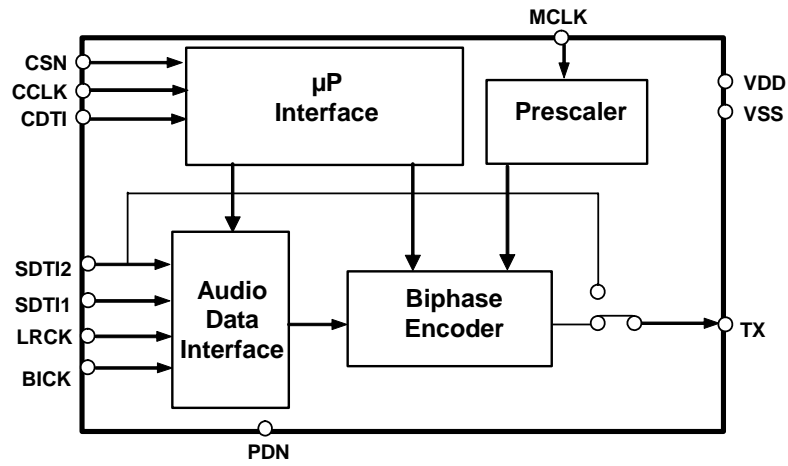


Figure 2. AK4104 Block Diagram (Mode= "1")

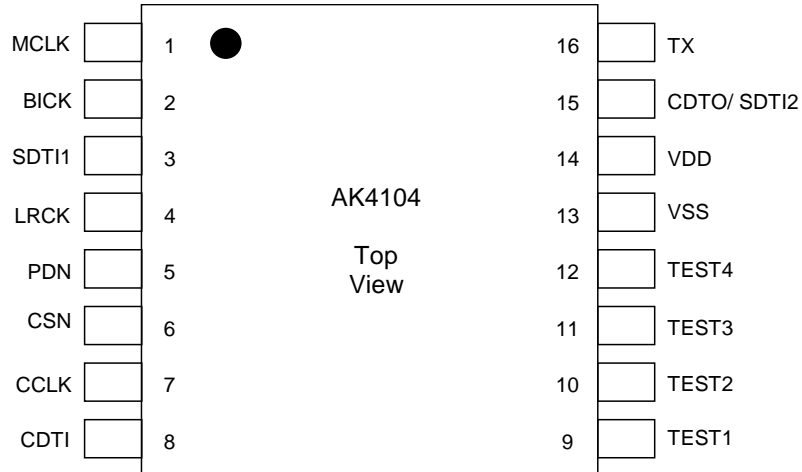
■ **Ordering Guide**

AK4104ET  
AKD4104

-20 ~ +85°C  
Evaluation Board for AK4104

16pin TSSOP (0.65mm pitch)

■ **Pin Layout**



<b>PIN/FUNCTION</b>
---------------------

No.	Pin Name	I/O	Function
1	MCLK	I	Master Clock Input Pin
2	BICK	I	Audio Serial Data Clock Pin
3	SDTI1	I	Audio Serial Data Input 1 Pin
4	LRCK	I	Input Channel Clock Pin
5	PDN	I	Power Down and Reset Pin “L”: Power down and Reset, “H”: Power up
6	CSN	I	Chip Select Pin
7	CCLK	I	Control Data Clock Pin
8	CDTI	I	Control Data Input Pin
9	TEST1	I	TEST Pin This pin should be connected to VDD.
10	TEST2	O	TEST Pin This pin should be OPEN.
11	TEST3	O	TEST Pin This pin should be OPEN.
12	TEST4	O	TEST Pin This pin should be OPEN.
13	VSS	-	Ground Pin
14	VDD	-	Power Supply Pin, 2.7 ~ 3.6V
15	CDTO	O	Control Data Output Pin, The output is “Hi-Z” when PDN pin = “L”.
	SDTI2	I	Audio Serial Data Input 2 Pin
16	TX	O	Transmit Channel Output Pin, The output is “L” when PDN pin = “L” or RSTN bit = “0” or PW bit = “0” or MCLK stops.

Note: All digital input pins should not be left floating.

**ABSOLUTE MAXIMUM RATINGS**

(VSS=0V; Note 1)

Parameter	Symbol	min	max	Units
Power Supply	VDD	-0.3	4.6	V
Input Current, Any Pin Except Supplies	IIN	-	±10	mA
Digital Input Voltage (Note 2)	VIND	-0.3	VDD+0.3	V
Ambient Temperature (Powered applied)	Ta	-20	85	°C
Storage Temperature	Tstg	-65	150	°C

Note 1. All voltages with respect to ground.

Note 2. MCLK, BICK, SDTI1, LRCK, PDN, CSN, CCLK, CDTI, SDTI2

WARNING: Operation at or beyond these limits may result in permanent damage to the device.

Normal operation is not guaranteed at these extremes.

**RECOMMENDED OPERATING CONDITIONS**

(VSS=0V; Note 1)

Parameter	Symbol	min	typ	max	Units
Power Supply	VDD	2.7	3.3	3.6	V

Note 1. All voltages with respect to ground.

WARNING: AKEMD assumes no responsibility for the usage beyond the conditions in this datasheet.

**DC CHARACTERISTICS**

(Ta=25°C; VDD=2.7 ~ 3.6V)

Parameter	Symbol	min	typ	max	Units
Power Supply Current (Note 3)					
Normal Operation (PDN pin = "H", fs=44.1kHz) (Note 3)			0.9	1.8	mA
Full power-down mode (PDN pin = "L") (Note 4)			10	50	µA
High-Level Input Voltage	VIH	70%VDD	-	-	V
Low-Level Input Voltage	VIL	-	-	30%VDD	V
High-Level Output Voltage (Iout=-80µA)	VOH1	VDD-0.4	-	-	V
Low-Level Output Voltage (Iout=80µA)	VOL1	-	-	0.4	V
Input Leakage Current	Iin	-	-	± 10	µA

Note 3. TX pin: open . Power supply current (IDD@3.3V) is 1.0mA(typ)@fs=48kHz, 1.4mA(typ)@fs=96kHz and 2.6mA(typ)@fs=192kHz. IDD is 10µA(typ) if PDN= "L" and all other input pins are held to VSS(@3.3V).

(TX pin: 20pF, Power supply current (IDD@3.3V) is 3.3mA(typ)@fs=192kHz.)

Note 4. All digital input pins are fixed to VDD or VSS.

**TX CHARACTERISTICS**

(Ta=25°C; VDD=2.7 ~ 3.6V)

Parameter	Symbol	min	typ	max	Units
High-Level Output Voltage ( Iout=-400µA)	VOH2	VDD-0.4	-	-	V
Low-Level Output Voltage ( Iout=400µA)	VOL2	-	-	0.4	V
Load Capacitance	CL	-	-	50	pF

<b>SWITCHING CHARACTERISTICS</b>					
(Ta=25°C; VDD=2.7 ~ 3.6V, CL=20pF)					
Parameter	Symbol	min	typ	max	Units
<b>Master Clock Frequency</b>					
Frequency	fCLK	2.048		36.864	MHz
Duty Cycle	dCLK	40		60	%
<b>LRCK Frequency</b>					
Frequency	fs	8		192	kHz
Duty Cycle	dCLK	45		55	%
<b>Audio Interface Timing</b>					
BICK Period	tBCK	81			ns
BICK Pulse Width Low	tBCKL	30			ns
Pulse Width High	tBCKH	30			ns
BICK “↑” to LRCK Edge	tBLR	20			ns
LRCK Edge to BICK “↑”	tLRB	20			ns
SDTI Hold Time	tSDH	20			ns
SDTI Setup Time	tSDS	20			ns
<b>Control Interface Timing</b>					
CCLK Period	tCCK	200			ns
CCLK Pulse Width Low	tCCKL	80			ns
Pulse Width High	tCCKH	80			ns
CDTI Setup Time	tCDS	40			ns
CDTI Hold Time	tCDH	40			ns
CSN “H” Time	tCSW	150			ns
CSN “↓” to CCLK “↑”	tCSS	150			ns
CCLK “↑” to CSN “↑”	tCSH	50			ns
CDTO Delay	tDCD			45	ns
CSN “↑” to CDTO Hi-Z	tCCZ			70	ns
<b>Power-Down &amp; Reset Timing</b>					
PDN Pulse Width	tPD	150			ns

Parameter	Symbol	min	typ	max	Units
<b>Master Clock Frequency</b>					
Frequency	fCLK	2.048		36.864	MHz
Duty Cycle	dCLK	40		60	%
<b>LRCK Frequency</b>					
Frequency	fs	8		192	kHz
Duty Cycle	dCLK	45		55	%
<b>Audio Interface Timing</b>					
BICK Period	tBCK	81			ns
BICK Pulse Width Low	tBCKL	30			ns
Pulse Width High	tBCKH	30			ns
BICK “↑” to LRCK Edge	tBLR	20			ns
LRCK Edge to BICK “↑”	tLRB	20			ns
SDTI Hold Time	tSDH	20			ns
SDTI Setup Time	tSDS	20			ns
<b>Control Interface Timing</b>					
CCLK Period	tCCK	200			ns
CCLK Pulse Width Low	tCCKL	80			ns
Pulse Width High	tCCKH	80			ns
CDTI Setup Time	tCDS	40			ns
CDTI Hold Time	tCDH	40			ns
CSN “H” Time	tCSW	150			ns
CSN “↓” to CCLK “↑”	tCSS	150			ns
CCLK “↑” to CSN “↑”	tCSH	50			ns
CDTO Delay	tDCD			45	ns
CSN “↑” to CDTO Hi-Z	tCCZ			70	ns
<b>Power-Down &amp; Reset Timing</b>					
PDN Pulse Width	tPD	150			ns

Note 5. BICK rising edge must not occur at the same time as LRCK edge.

Note 6. The AK4104 can be reset by bringing PDN pin = “L”.

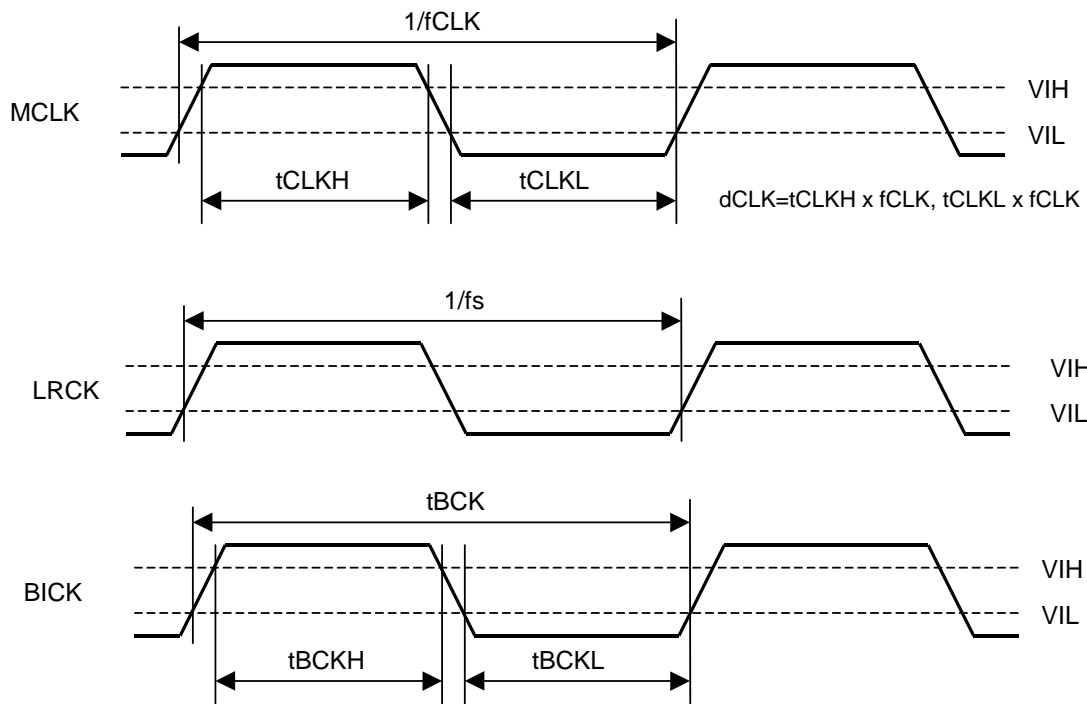
**■ Timing Diagram**


Figure 3. Clock Timing

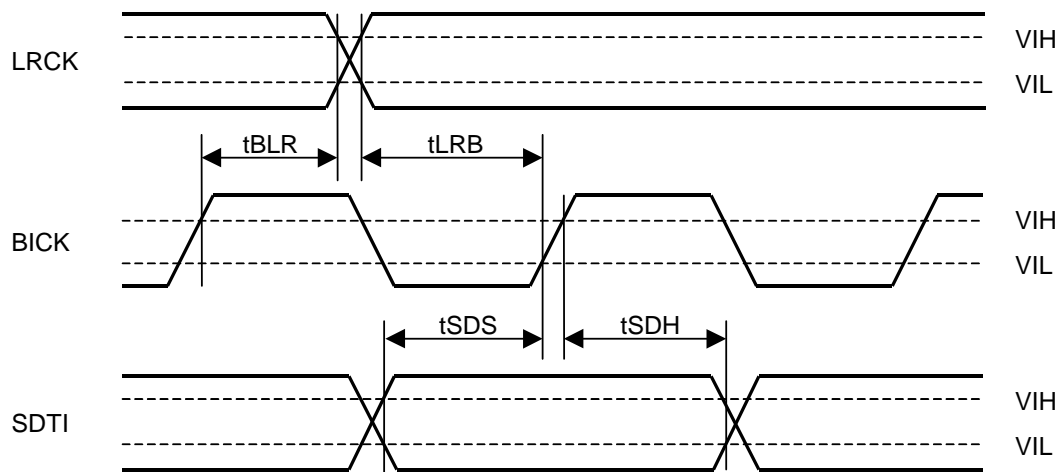


Figure 4. Serial Interface Timing

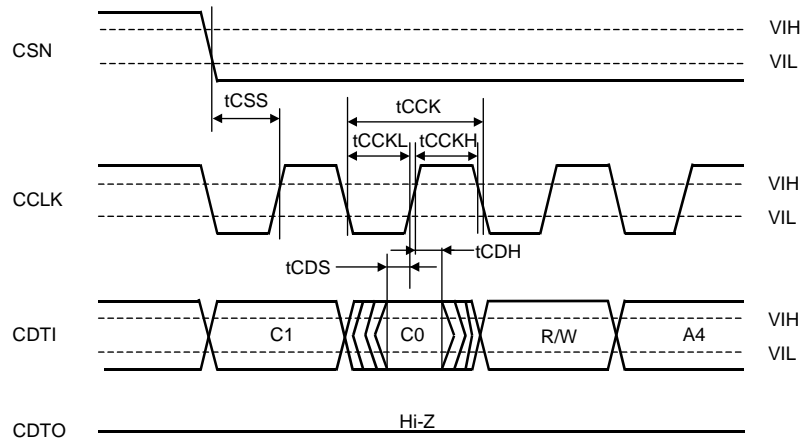


Figure 5. WRITE/READ Command Input Timing in 3-wire/4-wire serial mode

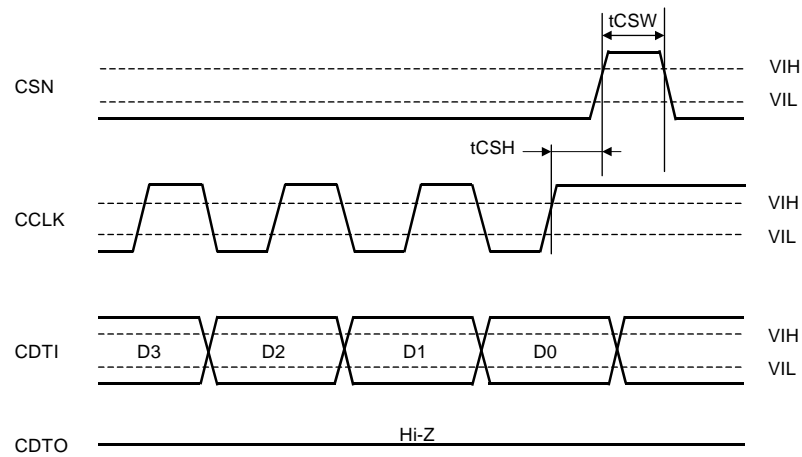


Figure 6. WRITE Data Input Timing in 3-wire/4-wire serial mode

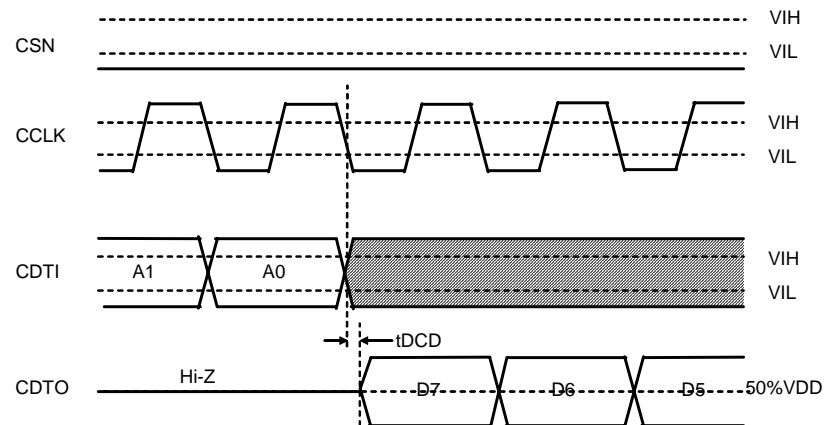


Figure 7. READ Data Output Timing 1 in 4-wire serial mode



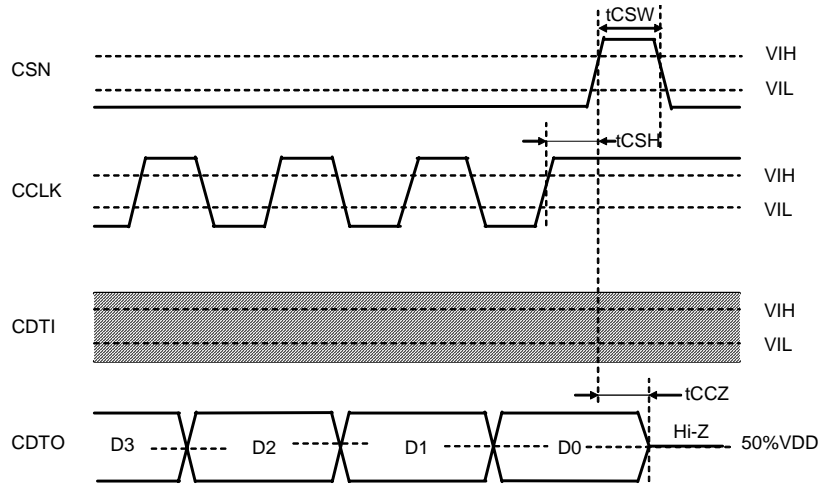


Figure 8. READ Data Output Timing 2 in 4-wire serial mode

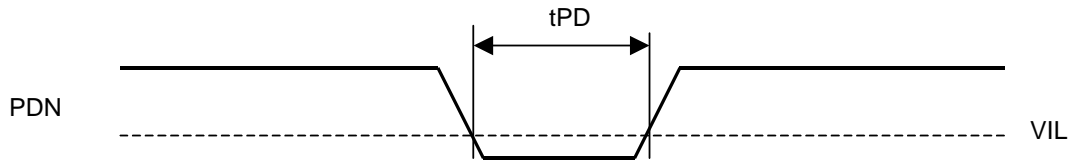


Figure 9. Power-Down & Reset Timing

**OPERATION OVERVIEW****■ Reset and Initialization**

The AK4104 should be reset once by bringing PDN = "L" upon power-up. It takes 8 bit clock cycles for the AK4104 to initialize after PDN pin goes "H".

**■ MCLK and LRCK Relationship**

For correct synchronization, MCLK and LRCK should be derived from the same clock signal either directly (as through a frequency divider) or indirectly (for example, as through a DSP). The phase relationship between MCLK and LRCK should be kept after power-up. The MCLK frequencies shown in Table 1 are supported. The internal clock frequency is set depending on the external MCLK frequency automatically.

MCLK	Fs
128fs	16k-192kHz
192fs	16k-192kHz
256fs	8k-128kHz
384fs	8k-96kHz
512fs	8k-48kHz
768fs	8k-48kHz
1024fs	8k-32kHz
1536fs	8k-24kHz

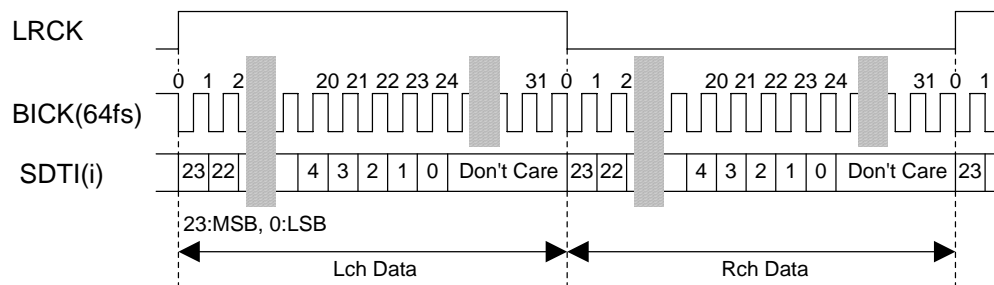
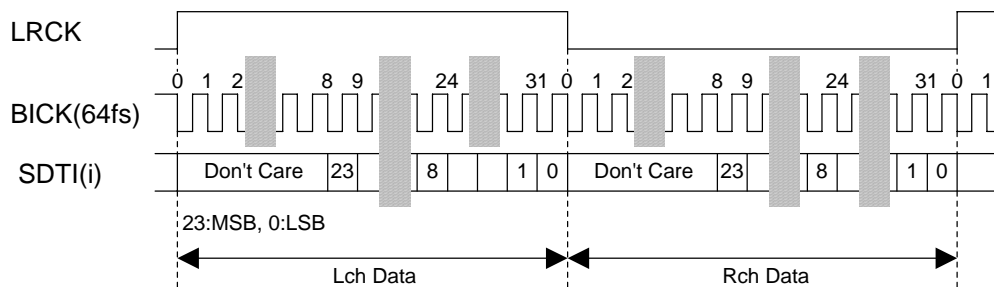
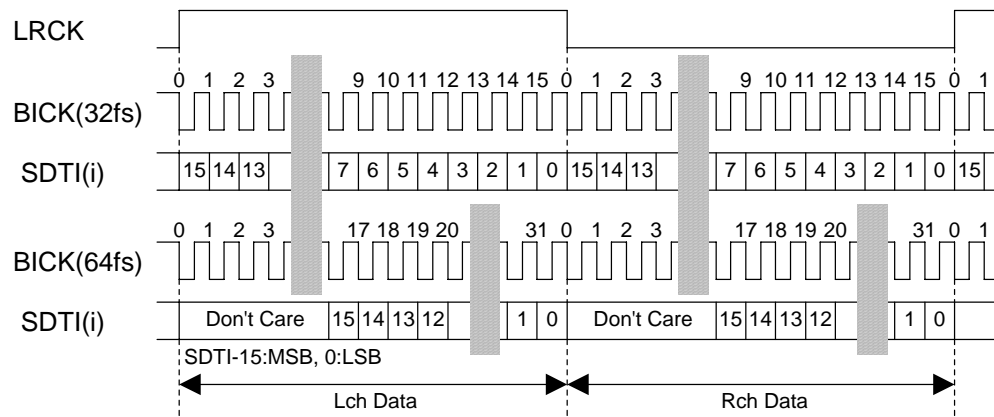
Table 1. MCLK Frequency

## ■ Audio Interface Format

Data is shifted in via the SDTI pin using BICK and LRCK inputs. The DIF1-0 bits as shown in Table 2 can select four serial data modes. In all modes the serial data is MSB-first, 2's complement format and is latched on the rising edge of BICK. Mode 3 can be used for 16bit I<sup>2</sup>S Compatible format by zeroing the unused LSBs at BICK  $\geq$  48fs or BICK = 32fs.

Mode	DIF1	DIF0	SDTI Format	BICK	Figure
0	0	0	16bit, LSB justified	$\geq$ 32fs	Figure 10
1	0	1	24bit, LSB justified	$\geq$ 48fs	Figure 11
2	1	0	24bit, MSB justified	$\geq$ 48fs	Figure 12
3	1	1	16/24bit, I <sup>2</sup> S Compatible	$\geq$ 48fs or 32fs	Figure 13

Table 2. Audio Interface Format



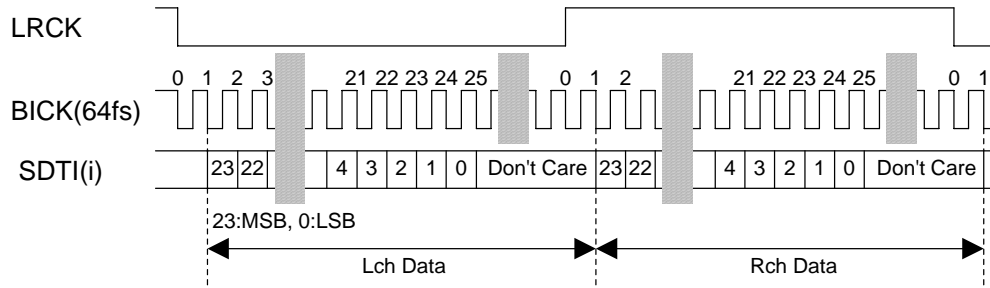


Figure 13. Mode 3 Timing

■ DIT input select

The AK4104 can select 4-wire  $\mu$ P I/F mode (MODE bit = "0") or 3-wire  $\mu$ P I/F mode (MODE bit = "1"). In 3-wire  $\mu$ P I/F mode, the AK4104 can select the input data of DIT from SDTI1 or SDTI2 data.

MODE	SEL1	SEL0	$\mu$ P I/F	DIT input
0	x	x	4-wire	SDTI1
1	0	0	3-wire	SDTI1
1	0	1	3-wire	SDTI2
1	1	0	3-wire	SDTI2:DIT Bypass
1	1	1	Reserved	

(x: Don't care)

Table 3. DIT Input

**Data Transmission Format**

The Data transmitted on the TX outputs is formatted in blocks as shown in Figure 14. Each block consists of 192 frames. A frame of data contains two sub-frames. A sub-frame consists of 32 bits of information. Each received data bit is coded using a bi-phase mark encoding as a two binary state symbol. The preambles violate bi-phase encoding so they may be differentiated from data. In bi-phase encoding, the first state of input symbol is always the inverse of the last state of the previous data symbol. For a logic 0, the second state of the symbol is the same as the first state. For a logic 1, the second state is opposite of the first. Figure 15 illustrates a sample stream of 8 data bits encoded in 16 symbol states.

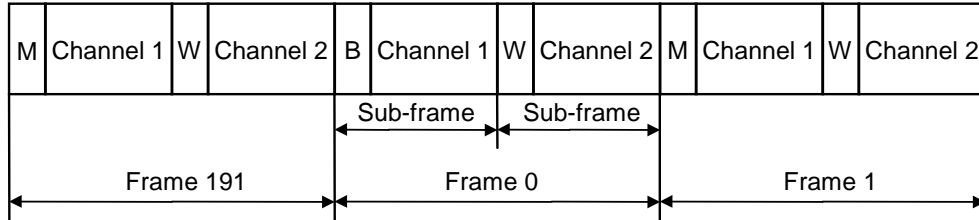


Figure 14. Block format

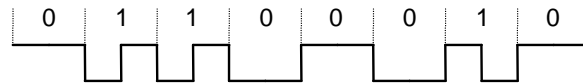


Figure 15. A biphas-encoded bit stream

The sub-frame is defined in Figure 16 below. Bits 0-3 of the sub-frame represent a preamble for synchronization. There are three preambles. The block preamble, B, is contained in the first sub-frame of Frame 0. The channel 1 preamble, M, is contained in the first sub-frame of all other frames. The channel 2 preamble, W, is contained in all of the second sub-frames.

Table 4 below defines the symbol encoding for each of the preambles. Bits 4-27 of the sub-frame contain the 24 bit audio sample in 2's complement format with bit 27 as the most significant bit. For 16 bit mode, Bits 4-11 are all 0. Bit 28 is the validity flag. It is "H" if the audio sample is unreliable. Bit 29 is a user data bit. Frame 0 contains the first bit of a 192 bit user data word. Frame 191 contains the last bit of the user data word. Bit 30 is a channel status bit. Again frame 0 contains the first bit of the 192 bit word with the last bit in frame 191. Bit 31 is an even parity bit for bits 4-31 of the sub-frame.

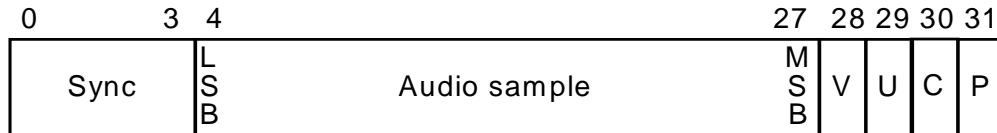


Figure 16. Sub-frame format

The block of data contains consecutive frames transmitted at a state-bit rate of 64 times the sample frequency, fs. For stereophonic audio, the left or A channel data is in channel 1 while the right or B data is in channel 2. For monophonic audio, channel 1 contains the audio data.

Preamble	Preceding state = 0	Preceding state = 1
B	11101000	00010111
M	11100010	00011101
W	11100100	00011011

Table 4. Sub-frame preamble encoding

**Channel Status bit**

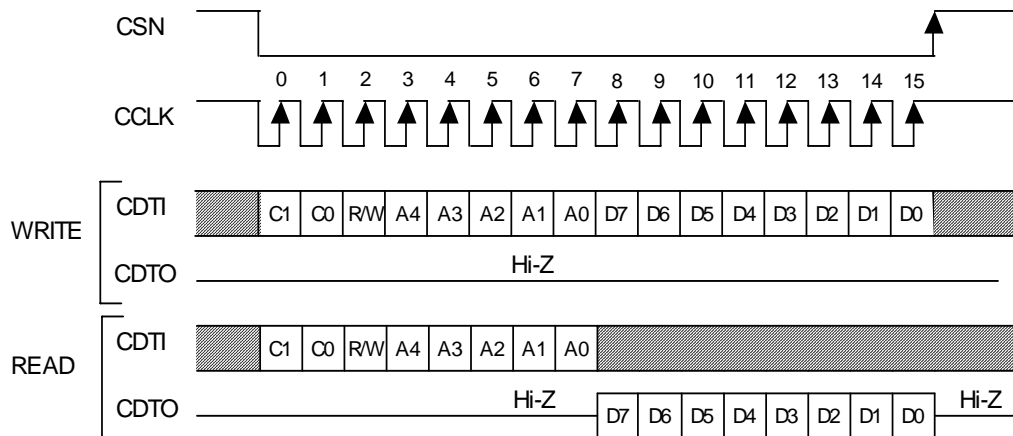
In the consumer mode (bit0 = "0"), bits20-23(audio channel) must be controlled by the CT20 bit. When the CT20 bit is "1", the AK4104 corresponds to "stereo mode", bits20-23 are set to "1000"(left channel) in sub-frame 1, and is set to "0100"(right channel) in sub-frame 2. When the CT20 bit is "0", bits20-23 is set to "0000" in both sub-frame 1 and sub-frame 2.

## ■ $\mu$ P Control Interface

The AK4104 can select 4-wire  $\mu$ P I/F mode (MODE bit = "0") or 3-wire  $\mu$ P I/F mode (MODE bit = "1").

### 1.4-wire Serial mode (MODE bit = "0", default)

The internal registers may be either written or read by the 4-wire  $\mu$ P interface pins: CSN, CCLK, CDTI and CDTO. The data on this interface consists of Chip address (2bits, C1/0; fixed to "11"), Read/Write (1bit), Register address (MSB first, 5bits) and Control data (MSB first, 8bits). Address and data are clocked in on the rising edge of CCLK and data is clocked out on the falling edge of CSN. CSN should be set to "H" once after the 16th CCLK. For read operations, the CDTO output goes high impedance after a low-to-high transition of CSN. The maximum speed of CCLK is 5MHz. PDN pin = "L" resets the registers to their default values.



C1-C0: Chip Address: (Fixed to "11")  
 R/W: READ/WRITE (0:READ, 1:WRITE)  
 A4-A0: Register Address  
 D7-D0: Control Data

Figure 17. 4-wire  $\mu$ P I/F Timing

\*When the AK4104 is in the power down mode (PDN pin = "L") or the MCLK is not provided, writing into the control register is inhibited.

### 2.3-wire $\mu$ P I/F mode (MODE bit = "1")

Internal registers may be written by 3-wire  $\mu$ P interface pins, CSN, CCLK and CDTI. The data on this interface consists of Chip Address (2bits, C1/0; fixed to "11"), Read/Write (1bit; fixed to "1", Write only), Register Address (MSB first, 5bits) and Control Data (MSB first, 8bits). The AK4104 latches the data on the rising edge of CCLK, so data should be clocked in on the falling edge. The writing of data becomes valid by 16th CCLK after a high to low transition of CSN. CSN should be set to "H" once after the 16th CCLK. The clock speed of CCLK is 5MHz (max).

PDN pin = "L" resets the registers to their default values. The internal timing circuit is reset by RSTN bit, but the registers are not initialized.

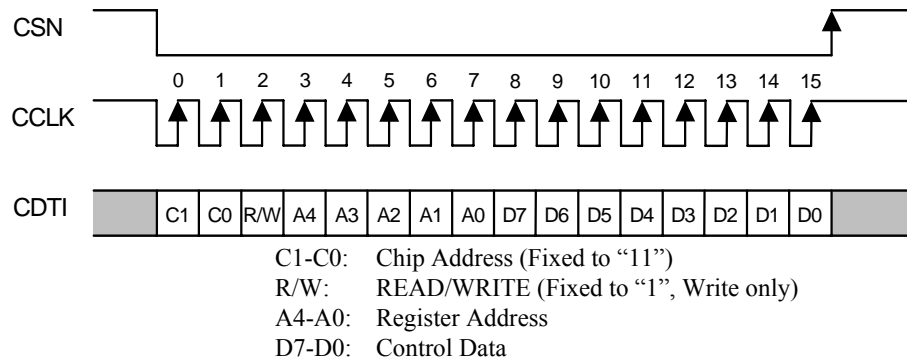


Figure 18. 3-wire  $\mu$ P I/F Timing

\*The AK4104 does not support the read command and chip address. C1/0 and R/W are fixed to "011"

\*When the AK4104 is in the power down mode (PDN pin = "L") or the MCLK is not provided, writing into the control register is inhibited.

## ■ Register Map

Addr	Register Name	D7	D6	D5	D4	D3	D2	D1	D0
00H	Control 1	1	0	0	0	DIF1	DIF0	PW	RSTN
01H	Reserved	0	1	0	1	1	0	1	1
02H	Control 2	0	0	0	0	0	MODE	SEL1	SEL0
03H	TX	1	0	0	0	0	0	V	TXE
04H	Channel Status Byte0	CS7	CS6	CS5	CS4	CS3	CS2	CS1	CS0
05H	Channel Status Byte1	CS15	CS14	CS13	CS12	CS11	CS10	CS9	CS8
06H	Channel Status Byte2	CS23	CS22	CS21	CS20	CS19	CS18	CS17	CS16
07H	Channel Status Byte3	CS31	CS30	CS29	CS28	CS27	CS26	CS25	CS24
08H	Channel Status Byte4	CS39	CS38	CS37	CS36	CS35	CS34	CS33	CS32
09H	Channel Status Byte5	0	0	0	0	0	0	CS41	CS40

Notes:

For addresses from 0AH to 1FH, data must not be written.

When PDN pin goes “L”, the registers are initialized to their default values.

When RSTN bit goes “0”, the only internal timing is reset and the registers are not initialized to their default values. All data can be written to the register even if PW or RSTN bit is “0”.

The “0” register should be written “0”, the “1” register should be written “1” data.

## ■ Register Definitions

Addr	Register Name	D7	D6	D5	D4	D3	D2	D1	D0
00H	Control 1	1	0	0	0	DIF1	DIF0	PW	RSTN
	R/W	R/W							
	Default	1	0	0	0	1	1	1	1

RSTN: Internal timing reset control

0: Reset. All registers are not initialized.

1: Normal Operation

PW: Power down control

0: Power down. All registers are not initialized.

1: Normal Operation

DIF1-0: Audio data interface formats (Table 2)

Initial: “11”, Mode 3



	Register Name	D7	D6	D5	D4	D3	D2	D1	D0
02H	Control 3	0	0	0	0	0	MODE	SEL1	SEL0
	R/W	R/W							
	Default	0	0	0	0	0	0	0	0

MODE: Mode Control

0: 4 wire mode

1: 3 wire mode

SEL1-0: DIT input

00: SDTI1 input

01: SDTI2 input

10: SDTI2 input (DIT Bypass)

11: Reserved

(NOTE) SEL1-0 bits can not use in 4 wire mode (MODE="0").

	Register Name	D7	D6	D5	D4	D3	D2	D1	D0
03H	TX	1	0	0	0	0	0	V	TXE
	R/W	R/W							
	Default	1	0	0	0	0	0	0	1

V: Validity Flag

0: Valid

1: Invalid

TXE: TX output

0: "L"

1: normal operation

	Register Name	D7	D6	D5	D4	D3	D2	D1	D0
04H	Channel Status Byte0	CS7	CS6	CS5	CS4	CS3	CS2	CS1	CS0
	Default	0	0	0	0	0	1	0	0
05H	Channel Status Byte1	CS15	CS14	CS13	CS12	CS11	CS10	CS9	CS8
	Default	0	0	0	0	0	0	0	0
06H	Channel Status Byte2	CS23	CS22	CS21	CS20	CS19	CS18	CS17	CS16
	Default	0	0	0	0	0	0	0	0
07H	Channel Status Byte3	CS31	CS30	CS29	CS28	CS27	CS26	CS25	CS24
	Default	0	0	0	0	0	0	0	0
08H	Channel Status Byte4	CS39	CS38	CS37	CS36	CS35	CS34	CS33	CS32
	Default	0	0	0	0	0	0	0	0
09H	Channel Status Byte5	0	0	0	0	0	0	CS41	CS40
	Default	0	0	0	0	0	0	0	0

CS7-0: Transmitter Channel Status Byte 0

Default: "00000100"

CS39-8: Transmitter Channel Status Byte 4-1

Default: "00000000"

CS41-CS40: Transmitter Channel Status Byte 5

Default: "00000000", D7-D2 bits should be written "1".

**SYSTEM DESIGN**

Figure 19 and Figure 20 shows the system connection diagram. The evaluation board AKD4104 demonstrates application circuits, the optimum layout, power supply arrangements and measurement results.

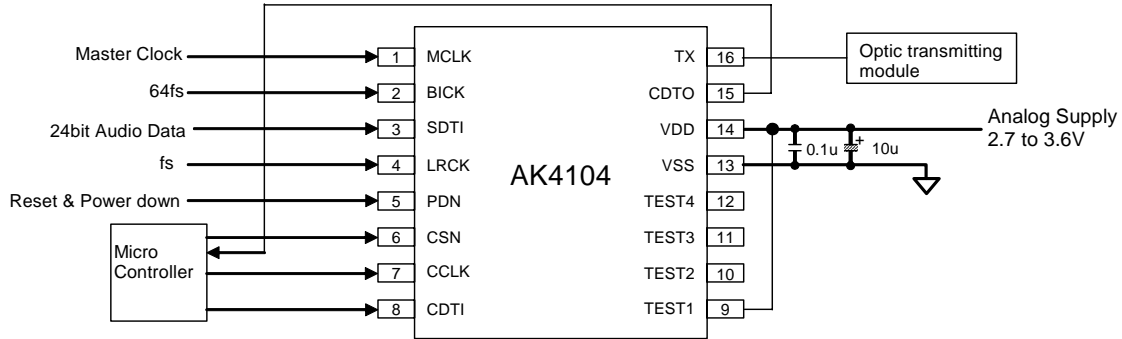


Figure 19. Typical Connection Diagram (Mode= "0", 4 wire mode )

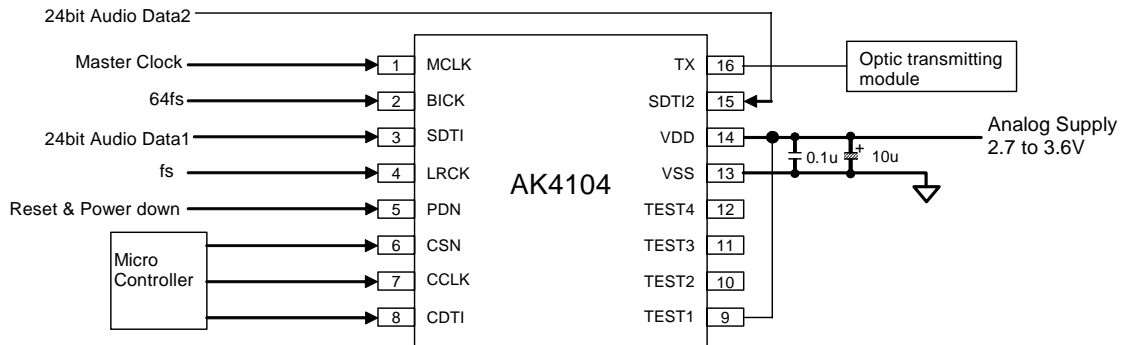
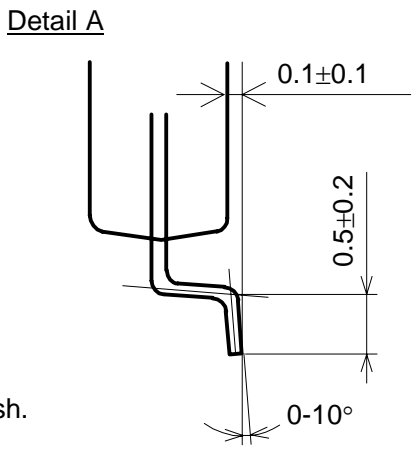
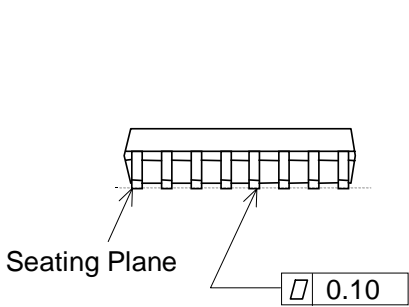
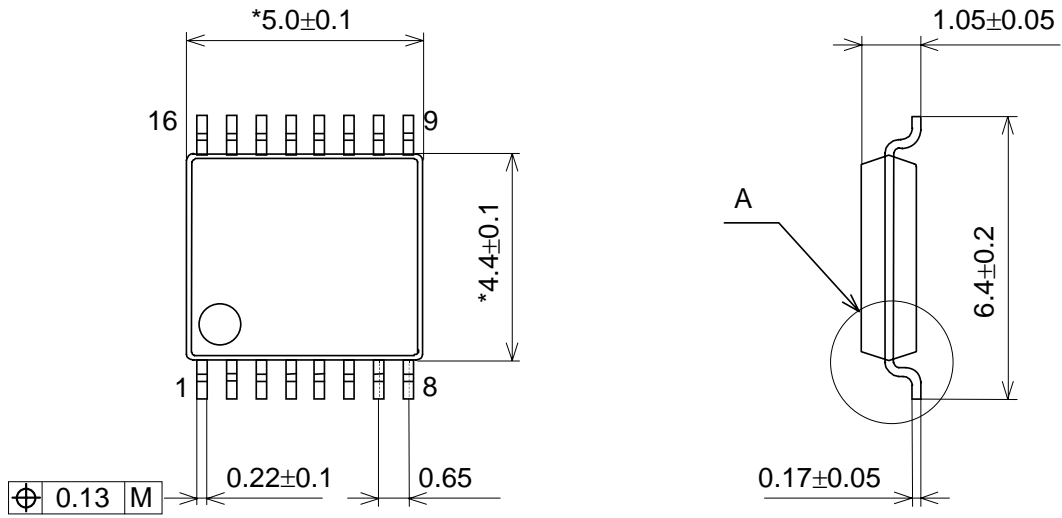


Figure 20. Typical Connection Diagram (Mode= "1", 3 wire mode )

PACKAGE

16pin TSSOP (Unit: mm)



NOTE: Dimension "\*" does not include mold flash.

■ Package & Lead frame material

- Package molding compound: Epoxy
- Lead frame material: Cu
- Lead frame surface treatment: Solder (Pb free) plate

<b>MARKING</b>
----------------



- 1) Pin #1 indication
- 2) Date Code : XXYYY (5 digits)  
     XX: Lot#  
     YYY: Date Code
- 3) Marketing Code : 4104ET
- 4) Asahi Kasei Logo

<b>REVISION HISTORY</b>
-------------------------

Date (YY/MM/DD)	Revision	Reason	Page	Contents
07/07/09	00	First Edition		

IMPORTANT NOTICE

- These products and their specifications are subject to change without notice.  
 When you consider any use or application of these products, please make inquiries the sales office of Asahi Kasei EMD Corporation (AKEMD) or authorized distributors as to current status of the products.
- AKEMD assumes no liability for infringement of any patent, intellectual property, or other rights in the application or use of any information contained herein.
- Any export of these products, or devices or systems containing them, may require an export license or other official approval under the law and regulations of the country of export pertaining to customs and tariffs, currency exchange, or strategic materials.
- AKEMD products are neither intended nor authorized for use as critical components<sup>Note1)</sup> in any safety, life support, or other hazard related device or system<sup>Note2)</sup>, and AKEMD assumes no responsibility for such use, except for the use approved with the express written consent by Representative Director of AKEMD. As used here:
  - Note1) A critical component is one whose failure to function or perform may reasonably be expected to result, whether directly or indirectly, in the loss of the safety or effectiveness of the device or system containing it, and which must therefore meet very high standards of performance and reliability.
  - Note2) A hazard related device or system is one designed or intended for life support or maintenance of safety or for applications in medicine, aerospace, nuclear energy, or other fields, in which its failure to function or perform may reasonably be expected to result in loss of life or in significant injury or damage to person or property.
- It is the responsibility of the buyer or distributor of AKEMD products, who distributes, disposes of, or otherwise places the product with a third party, to notify such third party in advance of the above content and conditions, and the buyer or distributor agrees to assume any and all responsibility and liability for and hold AKEMD harmless from any and all claims arising from the use of said product in the absence of such notification.