

# MEGA BRIGHT LED

## BTL-33BLD-XX-X

### Product Features

- Ultra Bright Blue Color
- High Light Output
- 3mm Diameter Circular Package
- Diffused Lens
- Highly Reliable
- IC Compatible
- Leads without Stand Off

### Package Dimension

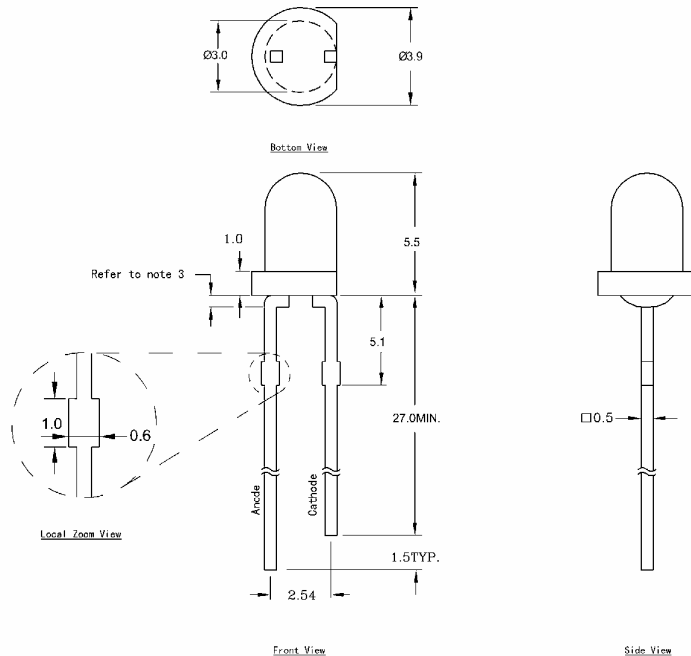

### Applications

- Automotive
- Front Panel Indicator
- Special Lighting
- General Purpose LEDs

**WARNING**

This range of LEDs is produced with die having a high radiant flux. Care must be taken when viewing the product at close range as the light may be intense enough to cause damage to the human eye.

**Note:** Industry standard procedures regarding static must be observed when handling this product.

inch	0.01
mm	0.25

### Optical and Electrical Characteristics at $T_a=25^\circ\text{C}$

Parameter	Symbol	Minimum	Typical	Maximum	Units	Conditions
Luminous Intensity	$I_v$	—	100	—	mcd	$I_F = 20\text{mA}$ (Note 1)
Viewing Angle	$2\theta_{1/2}$	—	60	—	deg	$I_F = 20\text{mA}$
Dominant Wavelength	$\lambda_D$	460	465	475	nm	$I_F = 20\text{mA}$ (Note 2)
DC Forward Voltage	$V_F$	2.8	3.5	4.0	V	$I_F = 20\text{mA}$
DC Reverse Current	$I_R$	0	—	10	$\mu\text{A}$	$V_R = 5\text{V}$

#### Notes:

1. Light intensity measures the light sensing response standard using chromatic meter. Refer to the CIE eye-response curve set by International Lighting committee. Tolerance of minimum and maximum intensity =  $\pm 15\%$
2. Wavelength range can be selected from the bin selection table. Tolerance of minimum and maximum =  $\pm 2\text{nm}$
3. These products are sensitive to static electricity and care must be fully taken when handling products



## MEGA BRIGHT LED BTL-33BLD-XX-X

Absolute Maximum Ratings at  $T_a=25^\circ\text{C}$

Symbol	Parameter	Max.	Unit
$P_D$	Power Rating	100	mW
$V_R$	Reverse Voltage ( $I_R=10\mu\text{A}$ )	5	V
$I_F$	Continuous Forward Current	30	mA
$I_{FP}$	Peak Forward Current (0.1 duty cycle @ 1kHz)	100	mA
$T_{opr}$	Operating Temperature Range	-35 ~ + 80	$^\circ\text{C}$
$T_{stg}$	Storage Temperature Range	-40 ~ + 100	$^\circ\text{C}$
Lead Soldering Temperature [1.6mm (0.063inch) from body]		260 $^\circ\text{C}$ - max 5 seconds	

Wavelength and Brightness Selection

### BTL-33BLD-XX-X

#### Wavelength Bin Selection

Bin	Blue (nm)
B5	460~465
B6	465~470
B7	470~475
XX	460~475

#### Brightness Bin Selection

Bin	Range(mcd)
C	45~60
D	60~80
E	80~110
F	110~140

#### Packaging Options

Standard: 1000 pc bulk pack

Optional: Tape and Reel (Please specify when order)



# MEGA BRIGHT LED

## BTL-33BLD-XX-X

Typical Electro-Optical Characteristics Curves at  $T_a=25^\circ\text{C}$

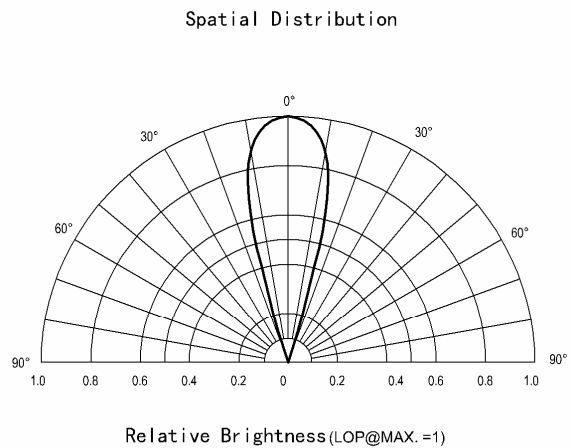
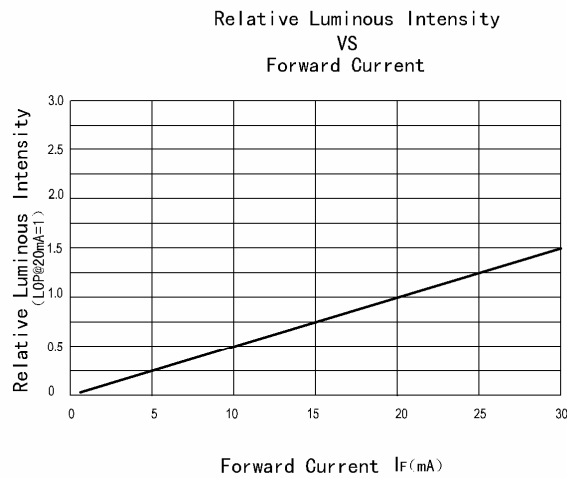
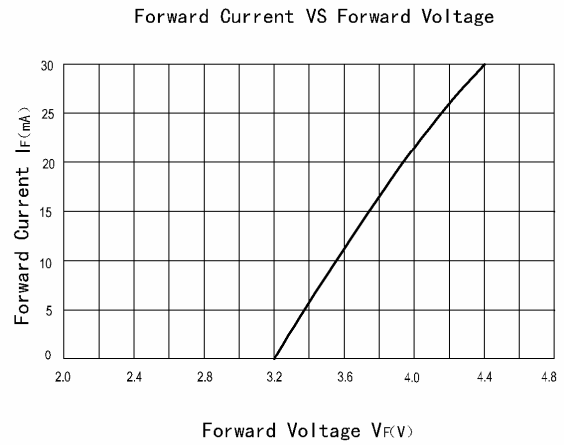
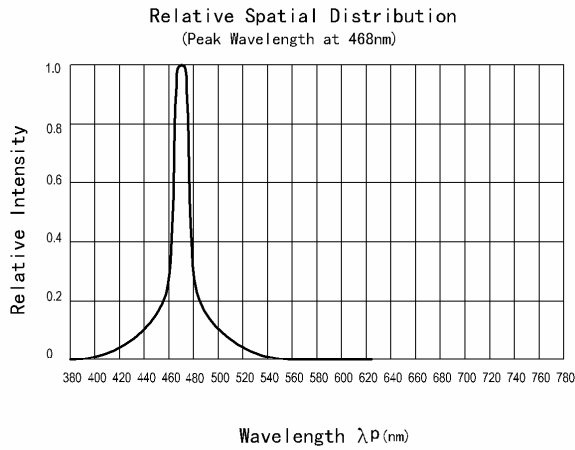

BT-Rev. 1.0a  
Specifications are subject to change without notice.  
Copyright © 2003 Brilliance Technologies Co., Ltd. All rights reserved.