

Preamplifier for High-Resolution Computer Display

Description

The CXA2067AS is a bipolar IC developed for high-resolution computer displays.

Features

- Wide-band amplifier: 170 MHz@-3 dB (Typ)
- Input dynamic range: 1.0 Vp-p (typ)
- High gain preamplifier (17 dB)
- R, G and B in a single package (SDIP 30 pins)
- I²C bus control
 - Contrast control
 - Sub contrast control
 - Brightness control
 - OSD contrast control
 - Cut-off control: 4 channels of DAC output
 - 2 blanking level modes
 - (0.5 V fixed, pedestal -0.3 V)
- Sync separator for sync-on-green
- Blanking mixing function
- OSC mixing function
- Video interval detection function
- VBLK sync DAC refresh system
- 12 V power supply interlocked power saving function

Applications

High-resolution computer displays

Structure

Bipolar silicon monolithic IC

30 pin SDIP (Plastic)

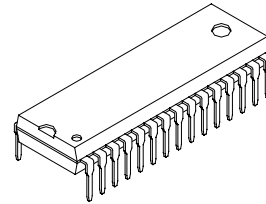

Absolute Maximum Ratings (Ta=25 °C, GND=0 V)

- | | | | |
|-------------------------------|-----------------------|-------------|----|
| • Supply voltage | V _{CC/R/G/B} | 14 | V |
| | V _{CC} | 7 | V |
| • Operating temperature | T _{opr} | -20 to +75 | °C |
| • Storage temperature | T _{stg} | -65 to +150 | °C |
| • Allowable power dissipation | P _D | 2.05 | W |

Recommended Operating Conditions

- | | | | |
|----------------|-----------------------|--------|---|
| Supply voltage | V _{CC/R/G/B} | 12±0.5 | V |
| | V _{CC} | 5±0.5 | V |

Sony reserves the right to change products and specifications without prior notice. This information does not convey any license by any implication or otherwise under any patents or other right. Application circuits shown, if any, are typical examples illustrating the operation of the devices. Sony cannot assume responsibility for any problems arising out of the use of these circuits.

Block Diagram

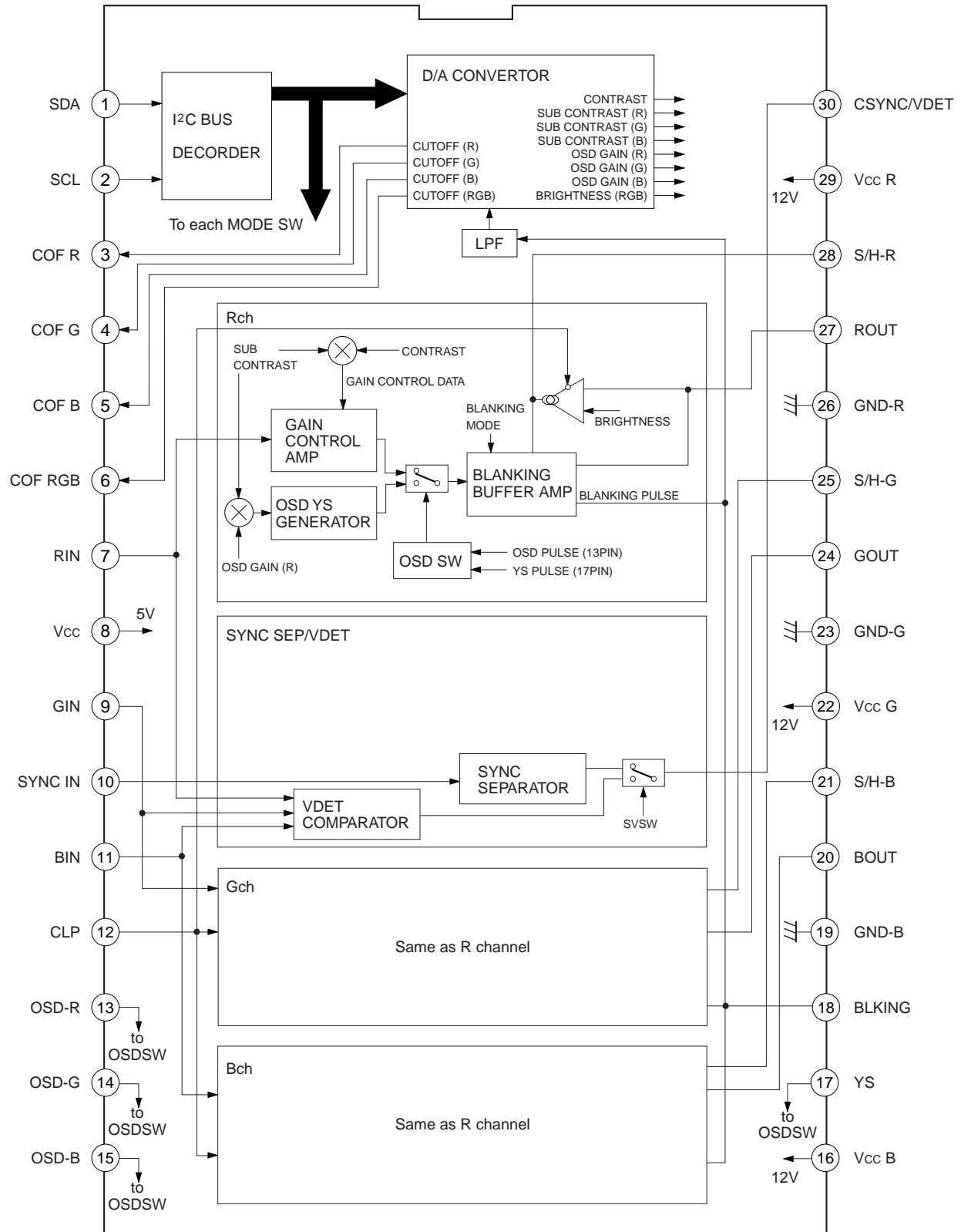

Pin Description

Pin No.	Symbol	Pin voltage	Equivalent circuit	Description
1	SDA	—		<p>I²C bus standard SDA (serial data) input/output. VILMAX=1.5 V VIHMIN=3.5 V VOLMAX=0.4 V</p>
2	SCL	—		<p>I²C bus standard SCL (serial clock) input/output. VILMAX=1.5 V VIHMIN=3.5 V</p>
3	COF R	—		<p>DAC output for cut-off adjustment. Output DC is 1 to 4 V.</p>
4	COF G			
5	COF B			
6	COF RGB			
7	RIN	1.8 V (Clamp)		<p>R, G and B signal inputs. Input via a capacitor.</p>
9	GIN			
11	BIN			
8	Vcc	5 V		5 V power supply.

Pin No.	Symbol	Pin voltage	Equivalent circuit	Description
10	SYNC IN	2.8 V		Sync-on-green signal input. Input via a capacitor.
12	CLP	—		Clamp pulse (positive polarity) input. VILMAX=0.8 V VIHMIN=2.8 V
13	OSD-R	—		OSD control inputs. VILMAX=0.8 V VIHMIN=2.8 V
14	OSD-G			
15	OSD-B			
16	Vcc B	12 V		12 V power supply. (B channel)
17	YS	—		YS (OSD BLK) control input. VILMAX=0.8 V VIHMIN=2.8 V

Pin No.	Symbol	Pin voltage	Equivalent circuit	Description
18	BLKING	—		Blanking pulse input. Set the V blanking pulse width to 300 μ s or more. $V_{ILMAX}=0.8$ V $V_{IHMIN}=2.8$ V
19	GND-B	0 V		Ground.
23	GND-G			
26	GND-R			
20	BOUT	—		R, G and B outputs.
24	GOUT			
27	ROUT			
21	S/H-B	—		Brightness sample-and-hold. Connect to GND via a capacitor.
25	S/H-G			
28	S/H-R			
22	Vcc G	12 V		12 V power supply. (G channel)
29	Vcc R	12 V		12 V power supply. (R channel)

Pin No.	Symbol	Pin voltage	Equivalent circuit	Description
30	CSYNC /VDET	—		<p>Sync-on-green signal sync separator output/video detector output.</p> <p>Either of them is selected by SVSW of I²C bus.</p> <p>Typ. : High=4.3 V Low=0.2 V (positive polarity)</p>

Definitions of I²C Bus Register

Slave Address

SLAVE RECEIVER : 40 (HEX)

Register Table

SUB ADDRESS	BIT7	BIT6	BIT5	BIT4	BIT3	BIT2	BIT1	BIT0
00h	CONTRAST							
01h	0	BLK MODE	BRIGHTNESS					
02h	CUT OFF R							
03h	CUT OFF G							
04h	CUT OFF B							
05h	VDET LEVEL		OSD GAIN					
06h	CUT OFF RGB							
07h	SUB CONTRAST R							
08h	SUB CONTRAST G							
09h	SUB CONTRAST B							
0Ah	VDET OFF	SVSW	*	*	*	*	*	VSOFF

Note) *: don't care

Sub Address CONTRAST (8): Performs the gain control for R, G and B channels in common.
0000
Control is performed by the multiplication with SUB CONTRAST. The white balance is adjusted by SUB CONTRAST and the luminance is adjusted by CONTRAST.

0 : Gain minimum (-30 dB or less)
255 : Gain maximum (+17 dB)

Sub Address BLK MODE (1): Switches the blanking level.
0001
0 : Pedestal-0.3 V
1 : 0.3 V fixed

Sub Address BRIGHTNESS (6): Performs the black level control for R, G and B channels in common.
0001
0 : Black level minimum (0.9 V)
63 : Black level maximum (2.8 V)

Sub Address CUT OFF R (8): Performs the Pin 3 (COF R) output voltage control.
0010
0 : Output voltage minimum (1 V)
255 : Output voltage maximum (4 V)

Sub Address CUT OFF G (8): Performs the Pin 4 (COF G) output voltage control.
0011
0 : Output voltage minimum (1 V)
255 : Output voltage maximum (4 V)

Sub Address CUT OFF B (8): Performs the Pin 5 (COF B) output voltage control.
0100
0 : Output voltage minimum (1 V)
255 : Output voltage maximum (4 V)

Sub Address 0101	VDET LEVEL (2):	Controls the signal detection (VDET) slice level. 0 : Slice level minimum (RIN or GIN or BIN=30 mV) 1 : Slice level maximum (RIN or GIN or BIN=220 mV)
Sub Address 0110	OSD GAIN (6):	Performs the OSD gain control for R, G and B channels in common. Control is performed by the multiplication with SUB CONTRAST (upper 6 bits) so that the video white balance and tracking are obtained. 0 : Gain minimum (0 Vp-p) 63 : Gain maximum (5 Vp-p)
Sub Address 0110	CUT OFF RGB (8):	Performs the Pin 6 (COF RGB) output voltage. 0 : Output voltage minimum (1 V) 255 : Output voltage maximum (4 V)
Sub Address 0111	SUB CONTRAST R (8):	Performs the R channel gain control. Control is performed by the multiplication with CONTRAST. Use for the white balance adjustment. 0 : Gain minimum (−30 dB or less) 255 : Gain maximum (+17 dB)
Sub Address 1000	SUB CONTRAST G (8):	Performs the G channel gain control. Control is performed by the multiplication with CONTRAST. Use for the white balance adjustment. 0 : Gain minimum (−30 dB or less) 255 : Gain maximum (+17 dB)
Sub Address 1001	SUB CONTRAST B (8):	Performs the B channel gain control. Control is performed by the multiplication with CONTRAST. Use for the white balance adjustment. 0 : Gain minimum (−30 dB or less) 255 : Gain maximum (+17 dB)
Sub Address 1010	VDET OFF (1):	Performs the Pin 30 output control. 0 : Output ON 1 : Output OFF
Sub Address 1010	SV SW (1):	Switches the Pin 30 output signal (sync separator/video detector). 0 : Sync separator output 1 : Video detector output
Sub Address 1010	VS OFF (1):	Performs the control of VBLK sync DAC refresh function. 0 : Function operation ON 1 : Function operation OFF

I²C Bus Logic System

No.	Item	Symbol	Min.	Typ.	Max.	Unit
1	High level input voltage	V _{IH}	3.0	—	5.0	V
2	Low level input voltage	V _{IL}	0	—	1.5	V
3	Low level output voltage with 3 mA SDA current inflow	V _{OL}	0	—	0.4	V
4	Maximum clock frequency	f _{SCL}	0	—	400	kHz
5	Minimum waiting time for data change	t _{BUF}	4.0	—	—	μs
6	Minimum waiting time for data transmission start	t _{HD} : STA	4.0	—	—	μs
7	Low level clock pulse width	t _{LOW}	4.7	—	—	μs
8	High level clock pulse width	t _{HIGH}	4.0	—	—	μs
9	Minimum waiting time for start preparation	t _{SU} : STA	4.7	—	—	μs
10	Minimum data hold time	t _{HD} : DAT	0	—	—	ns
11	Minimum data preparation time	t _{SU} : DAT	250	—	—	ns
12	Rise time	t _R	—	—	1	μs
13	Fall time	t _F	—	—	300	ns
14	Minimum waiting time for stop preparation	t _{SU} : STO	4.7	—	—	μs

Electrical Characteristics

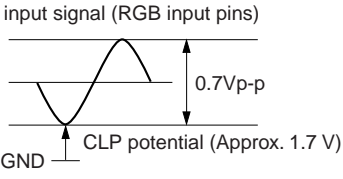
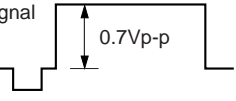
No.	Measurement item	Symbol	Measurement contents	Min.	Typ.	Max.	Unit
1	Current consumption (5 V)	I _{cc1}	V _{cc} (5 V) pin inflow current RGB signal input: None	85	115	140	mA
2	Current consumption (12 V)	I _{cc2}	V _{cc} R/G/B (12 V) pin inflow current RGB signal input: None	29.5	45	55.5	mA
3	Current consumption (12 V OFF)	I _{cc3}	V _{cc} pin inflow current for 12 V OFF RGB signal input: None	20	30	40	mA
4	Frequency response (50 MHz)	F50	Input the continuous 1 MHz, 50 MHz and 100 MHz sine waves (0.7 V _{p-p}). Measure the output amplitude gain difference at this time. Gain difference [dB]=20 log $\frac{V_{out} (50 \text{ MHz})}{V_{out} (1 \text{ MHz})}$ Gain difference [dB]=20 log $\frac{V_{out} (100 \text{ MHz})}{V_{out} (1 \text{ MHz})}$	-1.5	0	1.9	dB
5	Frequency response (100 MHz)	F100		-3.0	0	3.0	dB
6	Contrast control 1	GCONT1	Measure the output signal amplitude V _{out} level when a 0.7 V _{p-p} video signal is input. GCONT1 : Contrast=SubContrast=FF GCONT2 : Contrast=00/SubContrast=FF	5.6	6.2	—	V _{p-p}
7	Contrast control 2	GCONT2		—	0	100	mV _{p-p}
8	Sub contrast control	GSUB	Measure the output signal amplitude V _{out} level when a 0.7 V _{p-p} video signal is input. Contrast=FF/SubContrast=00	—	0	100	mV _{p-p}

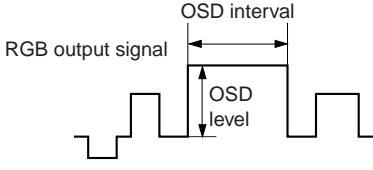
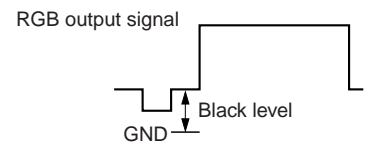
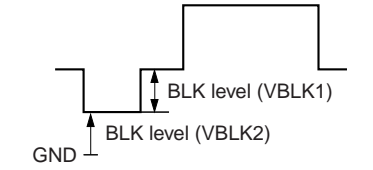
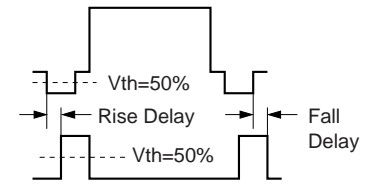
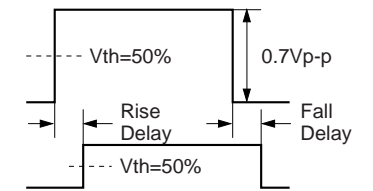
No.	Measurement item	Symbol	Measurement contents	Min.	Typ.	Max.	Unit
9	OSD gain control	GOSD1	Measure the OSD level of the output signal when the OSD pulse is input. GOSD1 : OSD=3F/SubContrast=FF GOSD2 : OSD=00/SubContrast=FF	4.5	5	—	Vp-p
		GOSD2		—	0	150	mVp-p
10	Brightness control	VBRT1	Measure the black level of the RGB output signal. VBRT1 : Brightness=00 VBRT2 : Brightness=3F	0.4	0.7	1	V
		VBRT2		2.2	2.6	3	
11	BLK control (BLK MODE=0)	VBLK1	Measure the BLK level of the output signal when the BLK pulse is input.	—	0.3	0.6	V
	BLK control (BLK MODE=1)	VBLK2			—	0.3	
12	Sync separator output rise delay	SDLYR		—	30	40	ns
	Sync separator output fall delay	SDLYF		—	60	80	
13	VDET output rise delay	DDLYR		—	20	40	ns
	VDET output fall delay	DDLYF		—	30	60	

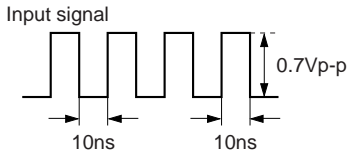
No.	Measurement item	Symbol	Measurement contents	Min.	Typ.	Max.	Unit
14	DAC output voltage (COFF=00)	VCUT1	Measure the DAC output voltage (Pin 6) for COFF=00/FF.	—	1	1.3	V
	DAC output voltage (COFF=FF)	VCUT2		3.9	4	—	
15	VDET output amplitude	VDET	<p>Input the crosshatch signal of DotClock=100 MHz/0.7 Vp-p and measure the VDET output amplitude. SW SW=1/VDET LEVEL=0</p>  <p>The diagram shows a square wave labeled 'Input signal'. The period of the signal is indicated as 10ns. The peak-to-peak amplitude is indicated as 0.7Vp-p.</p>	3.85	4	—	Vp-p

Electrical Characteristics Measurement Circuit

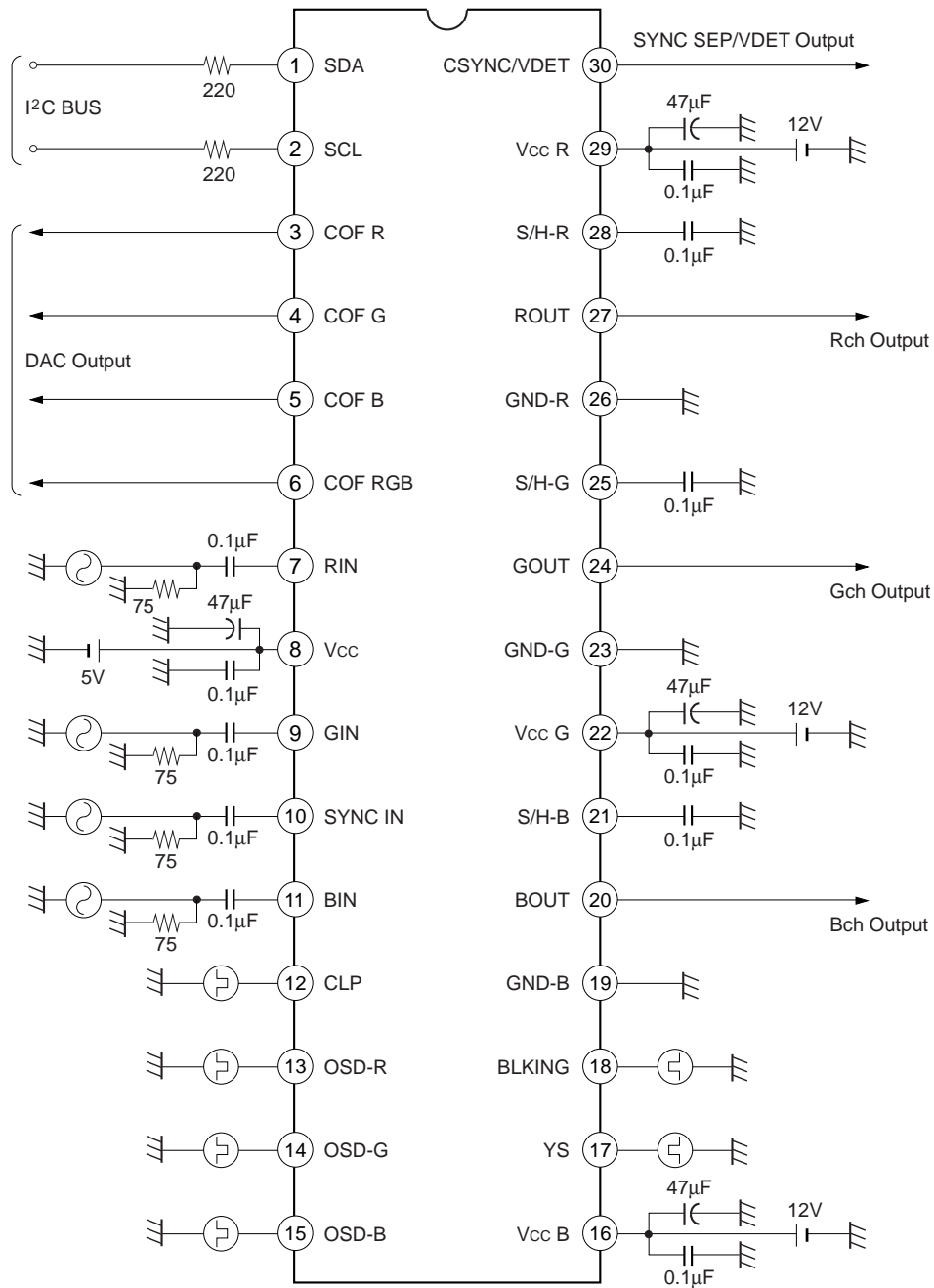

Electrical Characteristics Measurement Circuit (Frequency response)

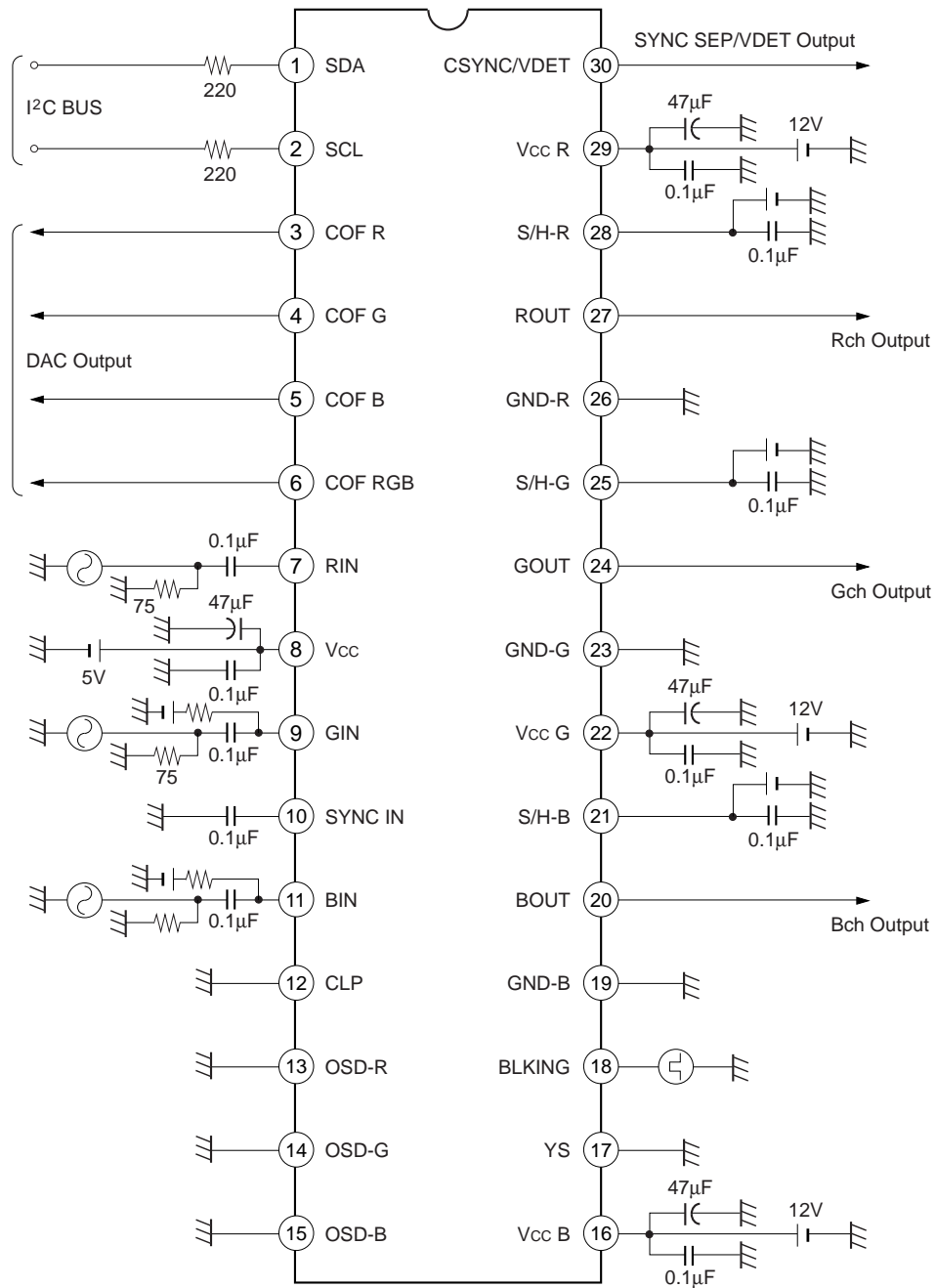

VBLK Sync DAC Refresh System

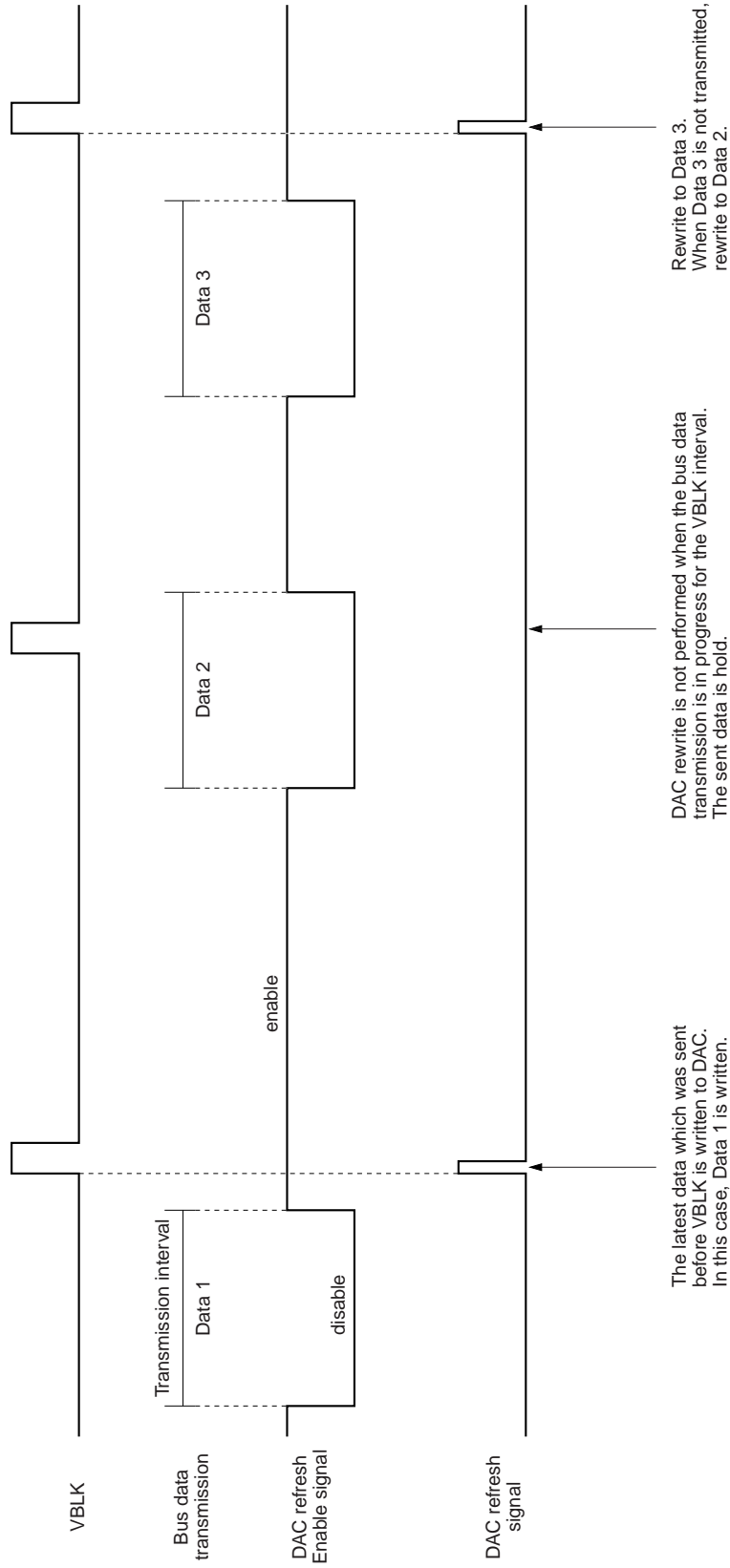

The VBLK signal is extracted from the composite BLK signal input to Pin 18. The DAC data rewrite for each control is simultaneously performed, synchronizing to the VBLK signal. The received I²C bus data is held by the latch till the next VBLK signal comes. Therefore, the timing of I²C bus data transmission from the microcomputer is free. The V blanking pulse width input to Pin 18 should be 300µs or more.

Application Circuit

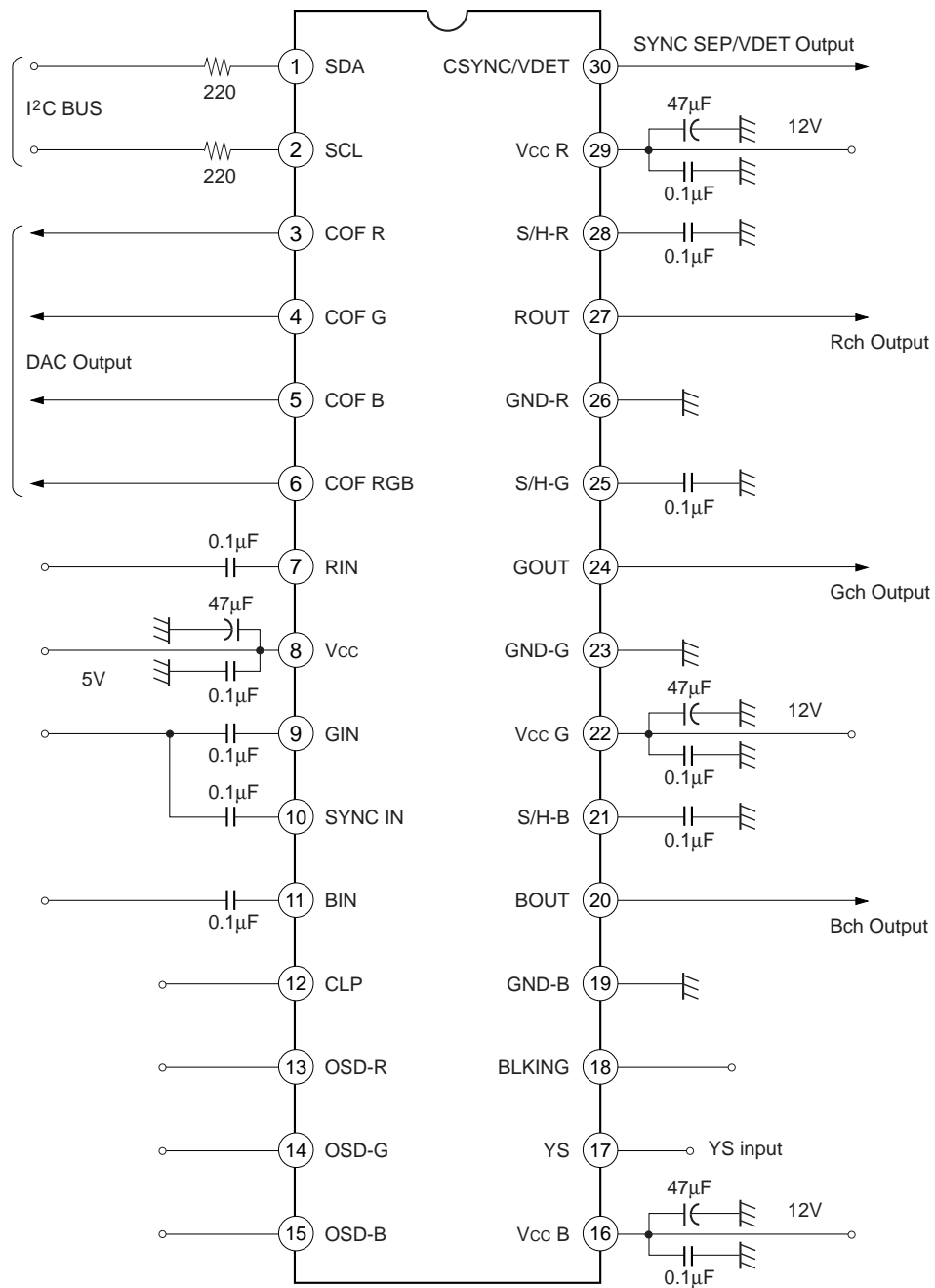

Application circuits shown are typical examples illustrating the operation of the devices. Sony cannot assume responsibility for any problems arising out of the use of these circuits or for any infringement of third party patent and other right due to same.

Notes on Operation

1. The ROUT, GOUT and BOUT outputs should be received in the high impedance state.
2. The wiring from ROUT, GOUT and BOUT to the power amplifier should be as short as possible.
3. For the decoupling capacitors for Vcc and Vcc R/G/B, the ceramic capacitor and the electrolysis capacitor should be connected in parallel as closely to the IC as possible.
4. The clamp capacitors for RIN, GIN, BIN, S/H R, S/H G and S/H B should be connected as close to the IC as possible.
5. The signals to RIN, GIN and BIN should be input via a clamp capacitor with the low impedance.
6. Set the output OFF when the VDET/CSYNC output is not used. (The cross talk may deteriorate)

Package Outline Unit : mm

30PIN SDIP (PLASTIC)

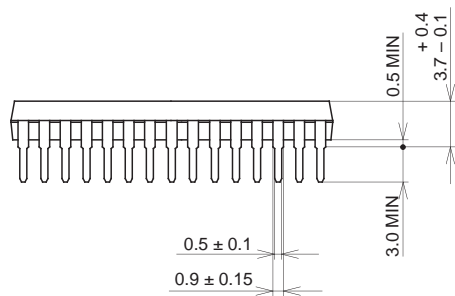
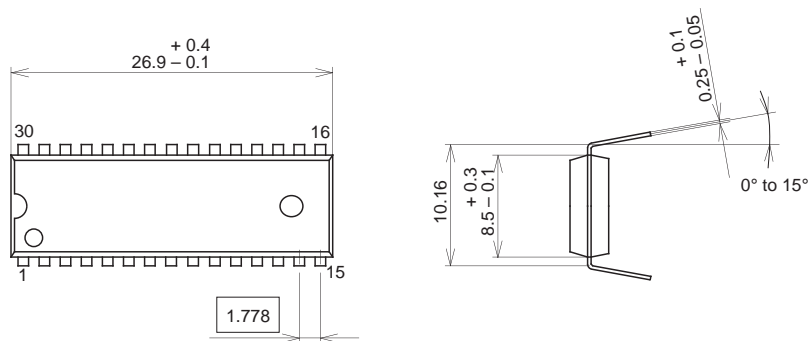

Two kinds of package surface:
 1. All mat surface type.
 2. All mirror surface type.

PACKAGE STRUCTURE

SONY CODE	SDIP-30P-01
EIAJ CODE	SDIP030-P-0400
JEDEC CODE	

MOLDING COMPOUND	EPOXY RESIN
LEAD TREATMENT	SOLDER/PALLADIUM PLATING
LEAD MATERIAL	COPPER ALLOY
PACKAGE MASS	1.8g