

**VOLTAGE DETECTOR/ON-OFF ALARM CIRCUIT**

**DESCRIPTION**

The M5232 is a unique semiconductor integrated circuit designed for use as a voltage detector/on-off alarm circuit.

Housed in a compact 8-pin SIP, the M5232L contains a comparator, reference voltage source, a vibrator circuit for turning the LED on and off, and a voltage regulation circuit. When the input voltage of the comparator at Pin ⑦ is higher than the internal reference voltage, the LED lights up, and when it is lower, the LED turns on and off. Also provided is an output pin (Pin ⑥) which does not operate intermittently but permits a relay or micro buzzer to be driven while the LED is being turned on and off by Pin ③. Signals from a low voltage checker for batteries, or from optical or thermal sensors are detected at the input pin of the comparator (Pin ⑦) allowing the M5232L to be applied widely in the alarm and protection circuits of electronic equipment.

**FEATURES**

- Starting supply voltage at which the LED will blink can be set optionally by using external resistors  $R_1$  and  $R_2$  (in the case of a low voltage checker for batteries)
- LED on/off frequency can be set optionally with external capacitor  $C_1$
- Built-in logic output pin (Pin ⑥) causes a high-to-low level transition as soon as the blinking begins
- Hysteresis operation is possible at the blink starting voltage using Pin ⑥
- LED lights when the input voltage of the comparator at Pin ⑦ is higher than the internal reference voltage, permitting the M5232L to be used as a pilot lamp for power ON indication

**PIN CONFIGURATION (TOP VIEW)**

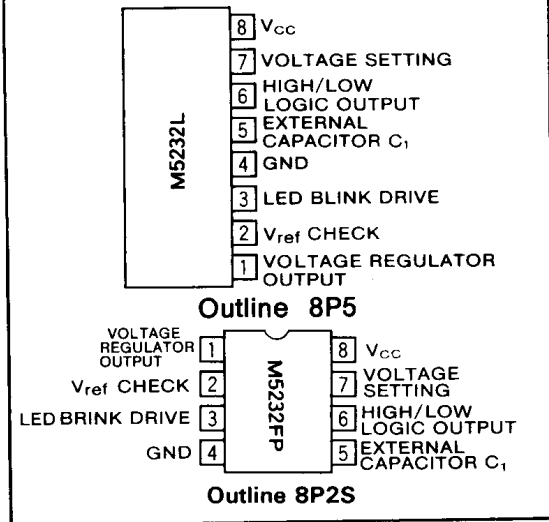

**APPLICATION**

Low voltage checker for batteries in equipment such as radio/cassette recorders, portable VCRs, cameras. Alarm and protection circuits of electronic equipment.

**RECOMMENDED OPERATING CONDITION**

Supply voltage range .....  $V_{CC}=5\sim 18V$

**BLOCK DIAGRAM**

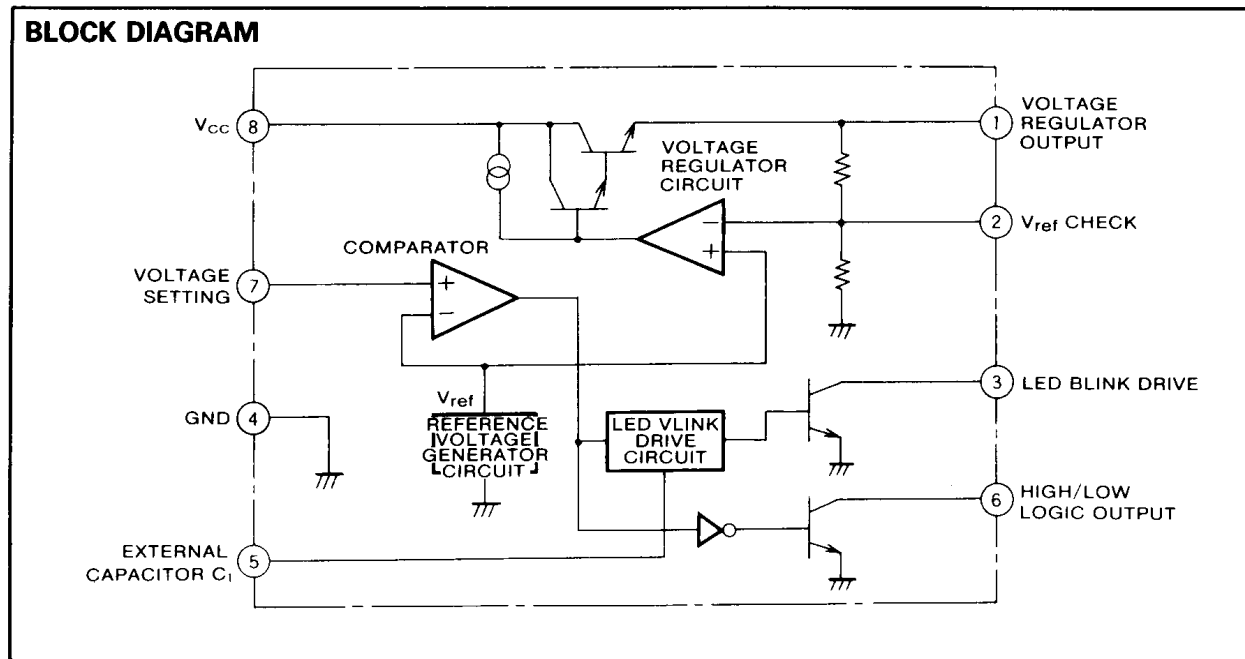

**VOLTAGE DETECTOR/ON-OFF ALARM CIRCUIT****ABSOLUTE MAXIMUM RATINGS** ( $T_a=25^\circ\text{C}$ , unless otherwise noted)

Symbol	Parameter	Conditions	Ratings	Unit
$V_{CC}$	Supply voltage		20	V
$P_d$	Power dissipation		800(L)/440(FP)	mW
$I_{LP}$	Load current		50	mA
$K_\theta$	Thermal derating	$T_a \geq 25^\circ\text{C}$	8	mW/ $^\circ\text{C}$
$T_{opr}$	Operating temperature range		$-20 \sim +75$	$^\circ\text{C}$
$T_{stg}$	Storage temperature range		$-55 \sim +125$	$^\circ\text{C}$

**ELECTRICAL CHARACTERISTICS** ( $T_a=25^\circ\text{C}$ )

Symbol	Parameter	Test conditions	Limits			Unit
			Min	Typ	Max	
$I_{CC}$	Circuit current	$V_{CC}=9\text{V}, I_L=0$		2.0	3.0	mA
$V_2$	Reference voltage	$V_{CC}=9\text{V}, R_{L3}=400\ \Omega$	1.22	1.31	1.40	V
$V_1$	Output voltage	$V_{CC}=9\text{V}, R_{L3}=400\ \Omega$	3.6	4.0	4.4	V
$V_3$	Saturation voltage	$V_{CC}=9\text{V}, R_{L3}=400\ \Omega$		0.2	0.5	V
$V_6$	Saturation voltage	$V_{CC}=6\text{V}, R_{L6}=400\ \Omega$		0.2	0.5	V
f	Oscillation frequency	$V_{CC}=6\text{V}, C_1=4.7\ \mu\text{F}, R_{L3}=400\ \Omega$		1.8		Hz

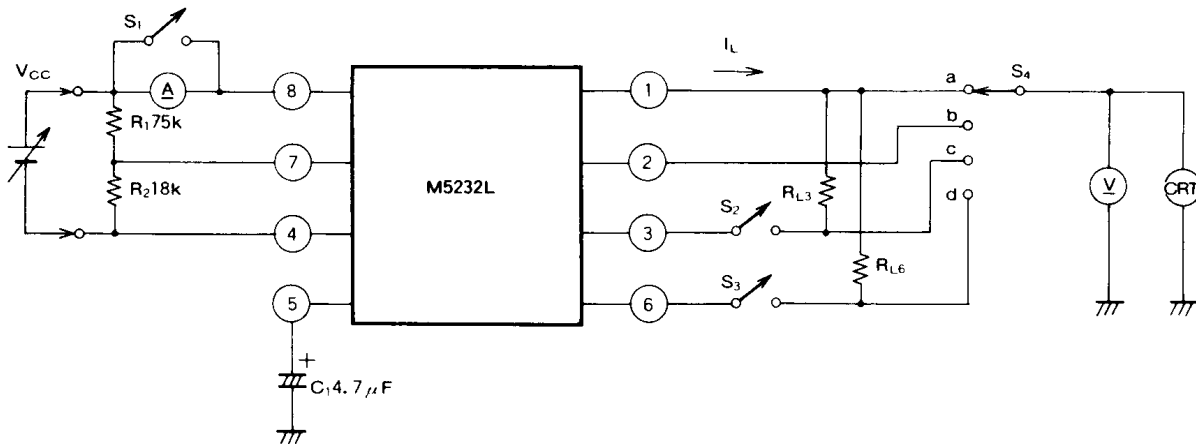
**TEST CIRCUIT**

☆ MEASUREMENT OF f ON CRT  
PIN ③ WAVEFORM  $f=1/T$  (Hz)

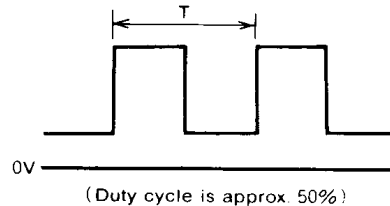

Parameter	$V_{CC}$	$S_1$	$S_2$	$S_3$	$S_4$
$I_{CC}$	9V	OFF	OFF	OFF	—
$V_2$	9V	ON	ON	OFF	b
$V_1$	9V	ON	ON	OFF	a
$V_3$	9V	ON	ON	OFF	c
$V_6$	6V	ON	OFF	ON	d
f	6V	ON	ON	OFF	c

# M5232L,FP

## VOLTAGE DETECTOR/ON-OFF ALARM CIRCUIT

### 1. Basic principle of M5232L operation

● When supply voltage  $V_{CC}$  is normal, the LED lights and functions as a pilot lamp. In this case, Pin ③ drives the LED with open-collector output.

●  $V_{CC}$  drops, becoming  $V_{CC1}$  and when the Pin ⑦ potential becomes

$$V_7 = \frac{R}{R_1 + R_2} \cdot V_{CC1} < V_{ref}$$

the comparator inverts, the blink circuit is switched on, and the LED blinks on and off. ( $V_{ref}$ , produced by the internal reference voltage source, is 1.31V typ.)

● The on/off alarm circuit shown on the right will activate when the voltage is 6.8V, which is 25% less than  $V_{CC} = 9V$  (six 1.5V cells).

● Pin ⑥ is an open-collector output that causes a high-to-low level transition simultaneously with the Pin ③ on/off operation. A micro buzzer, relay or other load can be connected across this pin and Pin ① of  $V_{CC}$  (Pin ⑧) for a wide range of applications.

### LOW VOLTAGE CHECKER FOR BATTERIES (SIMPLIFIED DIAGRAM)

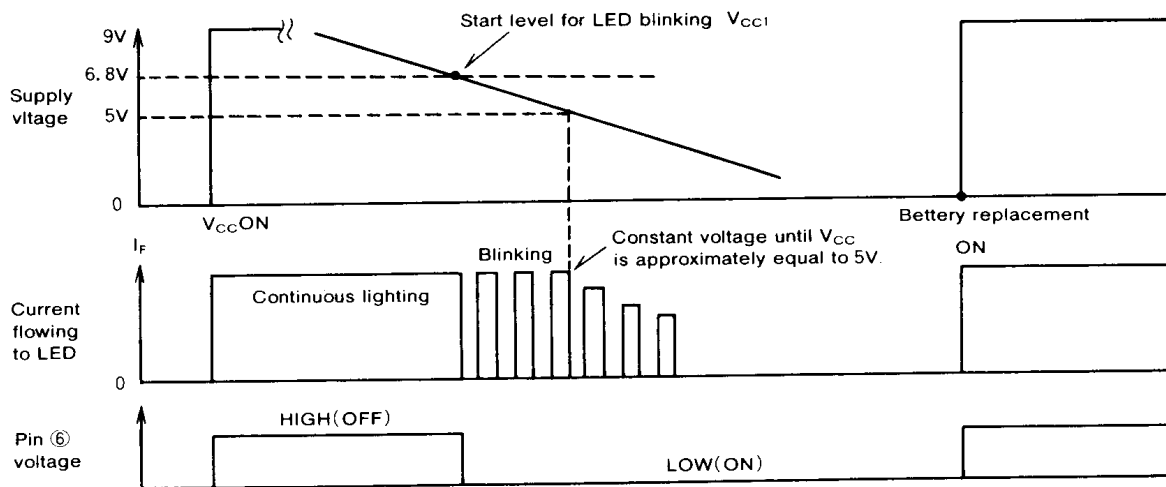
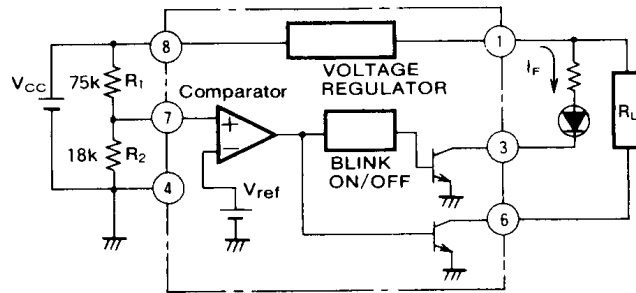

### 2. LED Drive current $I_F$

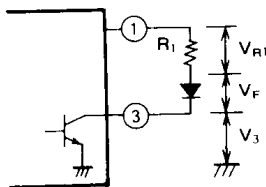

● Assuming that Pin ① output voltage is 4V, LED forward voltage is  $V_F$ , and  $V_3$  is 0.2V, then

$$I_F = \frac{4V - 0.2V - V_F}{R_1}$$

$I_F$  is approximately equal to 4.6mA with  $V_F = 2V$ , and  $R_1 = 390\Omega$  (in a typical application circuit).

### 3. On/off oscillation frequency

The on/off oscillation frequency can be varied by changing the value of external capacitor  $C_1$ .

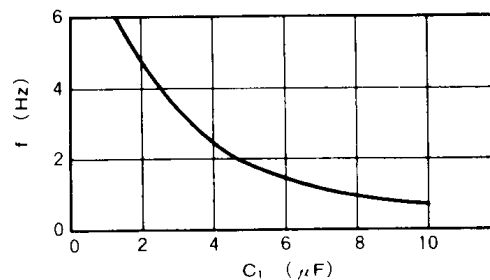

\* If capacitance  $C_1$  is even further reduced, oscillation will be possible up to a frequency of about 10 kHz

# M5232L,FP

## VOLTAGE DETECTOR/ON-OFF ALARM CIRCUIT

### TYPICAL CHARACTERISTICS

**POWER DISSIPATION VS. AMBIENT TEMPERATURE**

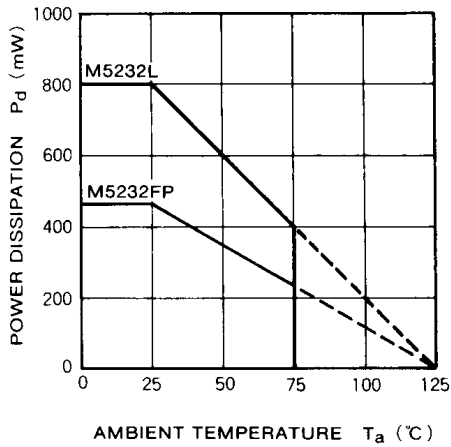

**OUTPUT VOLTAGE. REFERENCE VOLTAGE VS. SUPPLY VOLTAGE**

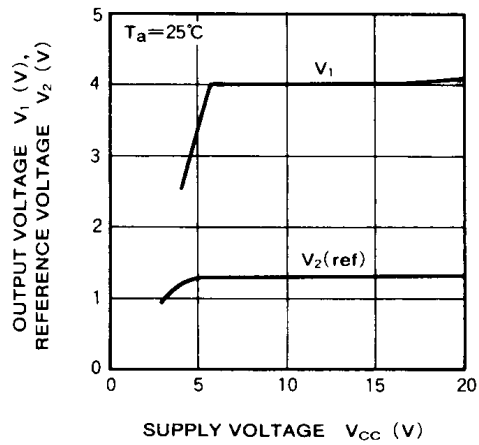

**OUTPUT VOLTAGE VS. LOAD CURRENT**

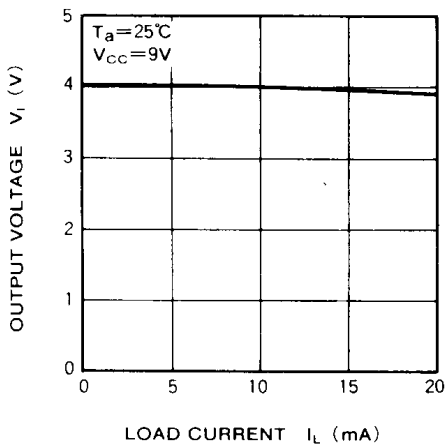

**SATURATION VOLTAGE VS. LOAD CURRENT**

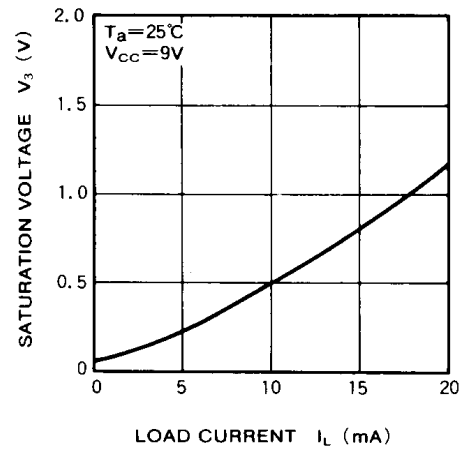

### PRINTED CIRCUIT BOARD FOR CIRCUIT TESTING (TYPICAL APPLICATION EXAMPLE)

**PRINTED CIRCUIT BOARD WIRING DIAGRAM (COPPER FOIL SIDE)**

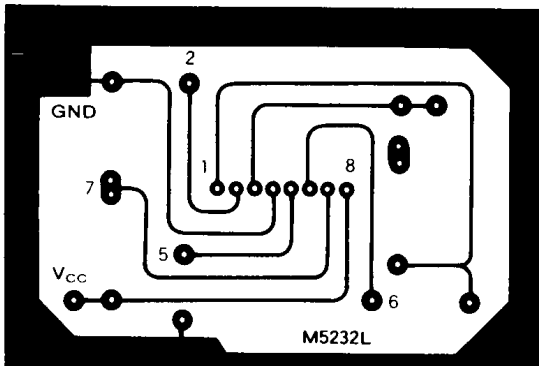

**(PARTS SIDE)**

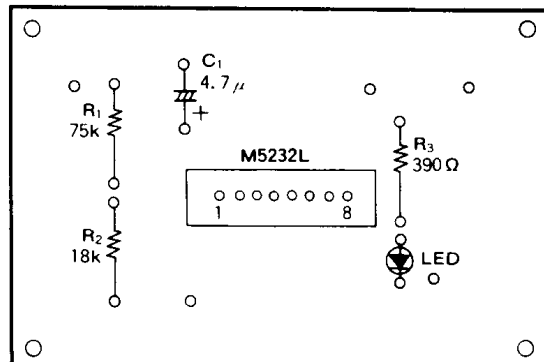

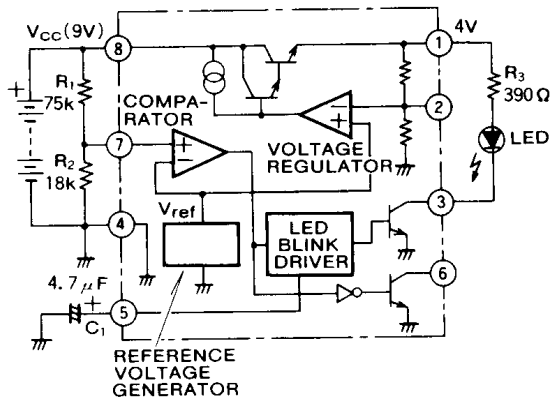
**VOLTAGE DETECTOR/ON-OFF ALARM CIRCUIT****APPLICATION EXAMPLES****1. Low voltage checker for batteries**

This low voltage checker for batteries is set to start the LED blinking when supply voltage  $V_{CC} = 9V$  (six 1.5V cells) is reduced by 25% (to 6.8V).

$$C_1 = 4.7 \mu F \rightarrow f \approx 1.8 \text{ Hz}$$

$C_2$ , which has a value of 100pF, prevents oscillation. It should be inserted when the input/output leads are long or when parasitic oscillation is generated by the load.

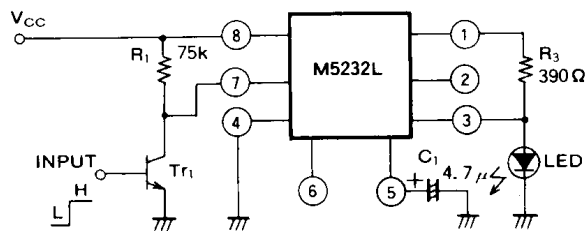
**2. Trouble indicator**

When the base of transistor  $T_{R1}$  is set low (the normal condition), Pin ⑦ comparator voltage is set high, Pin ③ is set low, and the LED is switched off.

When the base of transistor  $T_{R1}$  is set high (signifying trouble), Pin ⑦ comparator input voltage is set low, the internal vibrator circuit is switched on, Pin ③ is repeatedly set high and low, and the LED blinks on and off. At the same time, an electronic buzzer can be sounded using Pin ⑥ or a relay can be driven. (An ordinary switch may be used in place of transistor  $T_{R1}$ .)

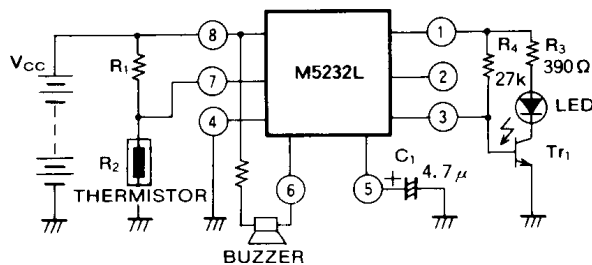
**3. Abnormal temperature indicator**

In normal circumstances, the LED is off and power dissipation is kept low. In abnormal circumstances, the LED blinks on and off. It is also possible to sound a buzzer or drive a relay using Pin ⑥.

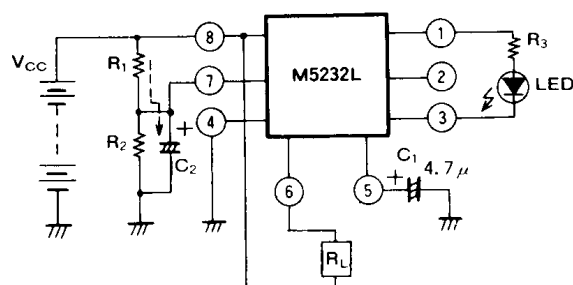
**4. Timer and muting indicator**

By connecting  $C_2$  in parallel with  $R_2$ ,  $V_{CC}$  is switched on, the charging current indicated by the dotted line in the figure flows, and the LED blinks on and off until the Pin ⑦ voltage reaches:

$$V_{CC} \cdot \frac{R_2}{R_1 + R_2}$$

When  $C_2$  is charged up, the LED will light. These operations can be applied to timer and muting circuits.

## VOLTAGE DETECTOR/ON-OFF ALARM CIRCUIT

## 5. Low voltage checker for batteries (of 5V or less)

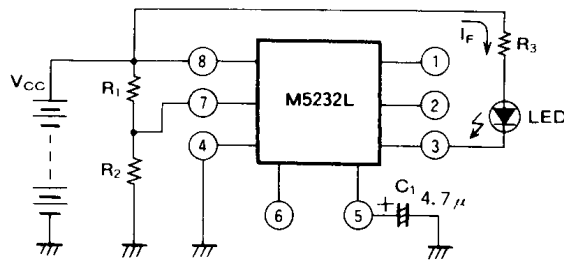

Since output Pin ① of the M5232L is regulated at 4V, the output is not stabilized at  $V_{CC}$  less than 5V.

When an LED is connected directly from  $V_{CC}$  as shown in the figure at left, it is possible to construct a battery checker for batteries of less than  $V_{CC}$  5V, (for instance,  $V_{CC}=3\sim 5V$ ). Note that in this case, the  $I_F$  of the LED will fluctuate in accordance with the changes in  $V_{CC}$ .

## 6. Hysteresis operation of the on/off starting voltage

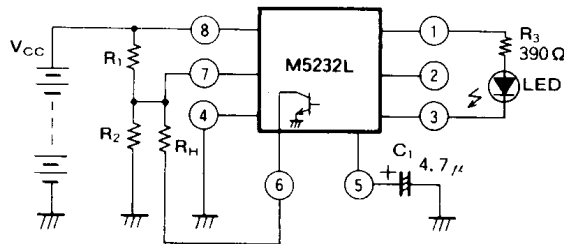

By connecting  $R_H$  across pins ⑥ and ⑦, as shown in the figure on the left, the on/off starting voltage is set at:

$$V_{2(\text{ref})} \cdot \frac{R_1 + R_2}{R_2}$$

After the start of the on/off blinking, Pin ⑥ (the open collector) goes on, and so it is possible to apply hysteresis and the voltage expressed below:

$$V_{2(\text{ref})} \cdot \frac{R_1 + R_2 // R_H}{R_2 // R_H}$$

## 7. Modification of output voltage V

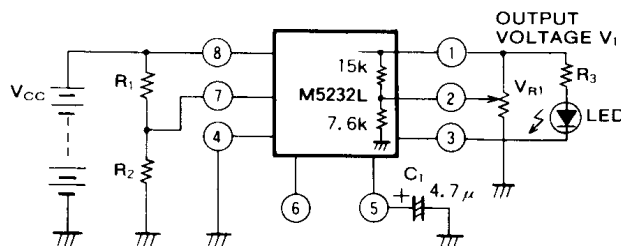

The output voltage  $V_1$  of the M5232L is set by the internal resistor as shown in the figure at left, but this can be changed by connecting a semi-fixed resistor across GND and pins ① and ②.

## 8. Increased current capacity of constant-voltage power supply

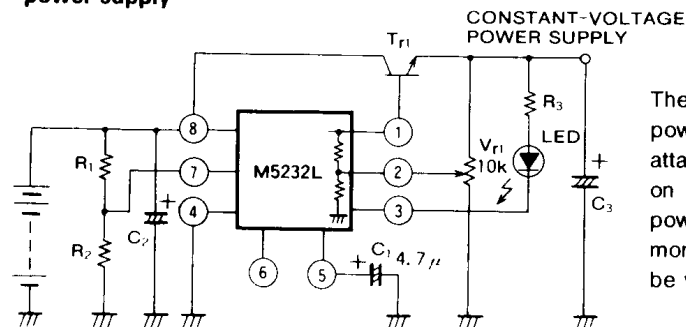

The current capacity of the built-in constant-voltage power supply is approximately 20mA. However, by attaching external transistor  $T_{R1}$  as shown in the figure on the left, it is possible to obtain a constant-voltage power supply with a large current capacity of 1A or more. The output voltage of the power supply can also be varied with variable resistor  $V_{R1}$ .

Note : Oscillation may be generated when the input or output leads are long. In cases like this, input and output capacitors  $C_1$  and  $C_2$  (1~10 $\mu$ F) should be inserted near the IC.