

AN7208SA

TV/FM front-end IC for 1.5 V headphone stereo

■ Overview

The AN7208SA is a TV/ FM front-end IC developed for use in the headphone stereo. It incorporates two systems of FM and VHF band front-end. A pre-amp. between IF amp. is not necessary by combination with the AN7233SH.

■ Features

- Built-in two system of FM and VHF band front-end
- Pre-amp. between IF amp. is not necessary (combination with the AN7233SH)
- Built-in standby /IF gain control/local oscillator buffer circuits

■ Applications

- 1.5 V headphone stereo (V_{CC} 1.0 V to 2.0 V)

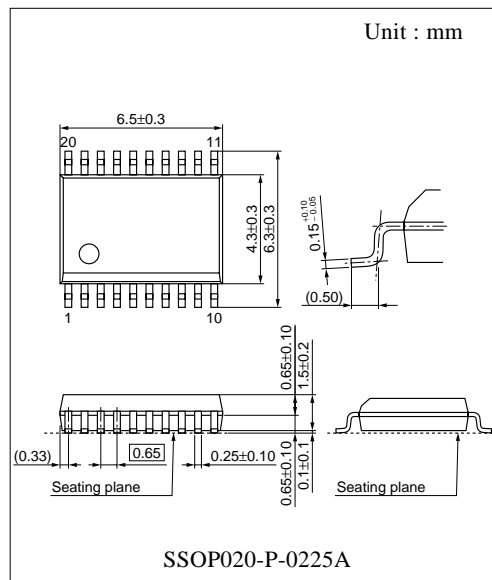

■ Block Diagram

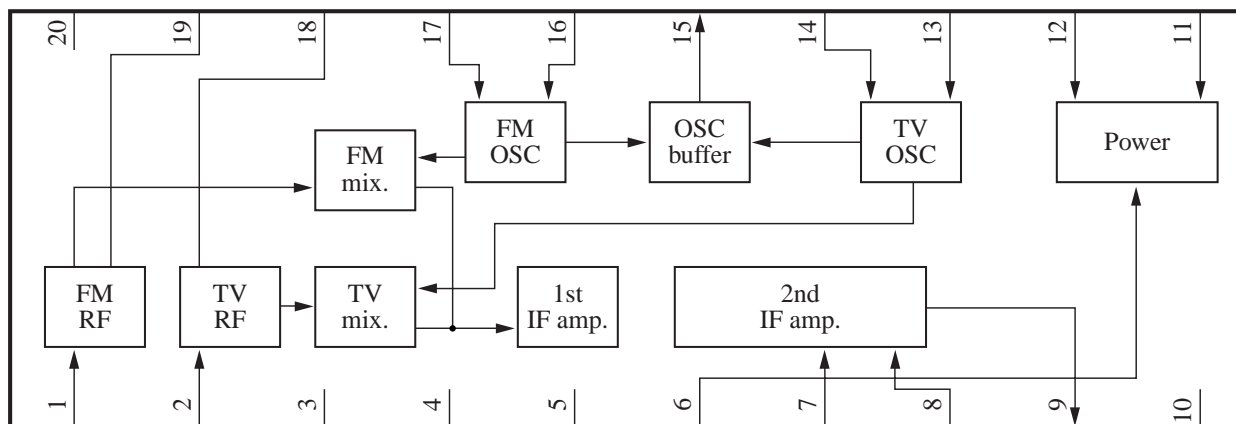

■ Pin Descriptions

Pin No.	Description	Pin No.	Description
1	FM RF input	11	V _{CC2}
2	TV RF input	12	STDBY
3	GND 1	13	TV OSC 1
4	N.C.	14	TV OSC 2
5	IF out 1	15	OSC buff.
6	Mode SW	16	FM OSC 1
7	IF in	17	FM OSC 2
8	IF gain control	18	TV RF
9	IF out 2	19	FM RF
10	GND 2	20	V _{CC1}

■ Absolute Maximum Ratings

Parameter	Symbol	Rating	Unit
Supply voltage	V _{CC}	2.5	V
Supply current	I _{CC}	12	mA
Power dissipation	P _D	30	mW
Operating ambient temperature *1	T _{opr}	-20 to +75	°C
Storage temperature *1	T _{stg}	-55 to +125	°C

Note) *1 : All items are at T_a = 25°C, except for the operating ambient temperature and storage temperature.

■ Recommended Operating Range

Parameter	Symbol	Range	Unit
Supply voltage	V _{CC}	1.0 to 2.0	V

■ Electrical Characteristics at V_{CC} = 1.2 V, T_a = 25°C

Parameter	Symbol	Conditions	Min	Typ	Max	Unit
TV f _{IN} = 221.75 MHz						
Conversion gain *1	G _{CONV(TV)}	f _{OUT} = 10.6 MHz	30	38	46	dB
Oscillation voltage	V _{OSC(TV)}	V _{CC} = 0.95 V	15	27	—	mV[rms]
S/N *2	S/N(TV)	Input level = 60 dBμ 1 kHz 30% Mod.	41	44	—	dB
Quiescent current	I _{TOT(TV)}	—	—	8.8	12	mA
Oscillation buffer output	V _{BUF(TV)}	V _{CC} = 0.95 V	39	62	—	mV[rms]

Note) Tuning is taken the peak point at 10.6 MHz output level (V_{IN} = 30 dBμ, non-modulation)

*1 : Conversion gain = 20 Log(ΔV (μV) ÷ 31.6)

ΔV is the output difference at V_{IN} = 30 dBμ and at V_{IN} = 36 dBμ

*2 : Measurement is done at the detection output of the AN7233

Measure the ratio of output at f_{DIV} = 22.5 kHz to that at f_{DIV} = 0 Hz (modulation freq. 1 kHz)

■ Electrical Characteristics at $V_{CC} = 1.2\text{ V}$, $T_a = 25^\circ\text{C}$ (continued)

Parameter	Symbol	Conditions	Min	Typ	Max	Unit
TV $f_{IN} = 221.75\text{ MHz}$ (continued)						
Burst noise *3	$V_{NO(TV)}$	Input level = 60 dB μ Non-modulation	-1.8	—	1.8	mV[p-0]
FM $f_{IN} = 107.88\text{ MHz}$						
Conversion gain *1	$G_{CONV(FM)}$	$f_{OUT} = 10.6\text{ MHz}$	30	38	46	dB
Oscillation voltage	$V_{OSC(FM)}$	$V_{CC} = 0.95\text{ V}$	40	63	—	mV[rms]
S/N *2	$S/N_{(FM)}$	Input level = 60 dB μ 1 kHz 30% mod.	48	51	—	dB
Quiescent current	$I_{TOT(FM)}$	—	—	7.7	10	mA
Oscillation buffer output	$V_{BUF(FM)}$	$V_{CC} = 0.95\text{ V}$	66	132	—	mV[rms]
Burst noise *3	$V_{NO(FM)}$	Input level = 60 dB μ Non-modulation	-1.8	—	1.8	mV[p-0]

Note) Tuning is taken the peak point at 10.6 MHz output level ($V_{IN} = 30\text{ dB}\mu$, non-modulation)

*1 : Conversion gain = $20 \text{ Log}(\Delta V (\mu\text{V}) \div 31.6)$

ΔV is the output difference at $V_{IN} = 30\text{ dB}\mu$ and at $V_{IN} = 36\text{ dB}\mu$

*2 : Measurement is done at the detection output of the AN7233

Measure the ratio of output at $f_{DIV} = 22.5\text{ kHz}$ to that at $f_{DIV} = 0\text{ Hz}$ (modulation freq. 1 kHz)

*3 : Measurement is done at the detection output of the AN7233

Measures a peak voltage of the measurement time = within 500 ms (OK to 10 times)

■ Terminal Equivalent Circuits

Pin No.	Equivalent circuit	Description	Input resistance or pin voltage
1		FM RF input RF signal input in FM band (Common base type)	Approx. $V_{CC} - 0.7\text{ V}$
2		TV RF input RF signal input in TV band (Common base type)	Approx. $V_{CC} - 0.7\text{ V}$

■ Terminal Equivalent Circuits (continued)

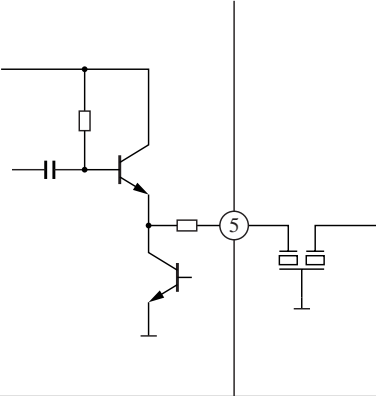
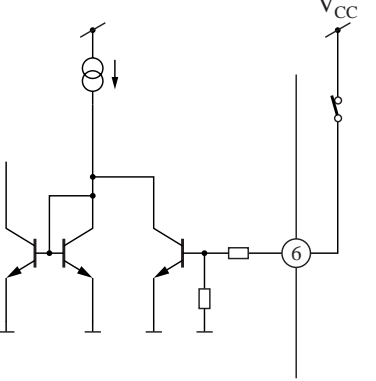
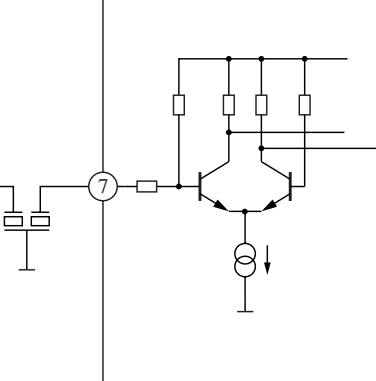
Pin No.	Equivalent circuit	Description	Input resistance or pin voltage
3	—	GND 1 GND pin (RF, mix. block)	—
4	—	N.C.	—
5		IF out 1 Outputs IF signal of TV/FM	Approx. 330 Ω Approx. $V_{CC} - 0.7$ V
6		Mode SW Switch of band switching V_{CC} : TV mode Open/GND : FM mode	—
7		IF in IF amp. block input	Approx. 5 kΩ

■ Terminal Equivalent Circuits (continued)

Pin No.	Equivalent circuit	Description	Input resistance or pin voltage
8		IF gain control IF amp. block gain can be decreased by inserting a resistance to GND.	Approx. 700 Ω Approx. 0.7 V
9		IF out 2 IF amp. block output	Approx. 330 Ω Approx. $V_{CC} - 0.7 V$
10	—	GND GND pin (IF, OSC block)	—
11	—	V_{CC2} Power supply pin (IF, OSC block)	—
12		STDBY Standby switch $V_{CC}/open$: IC off GND : IC operates	—

■ Terminal Equivalent Circuits (continued)

Pin No.	Equivalent circuit	Description	Input resistance or pin voltage
13		<p>TV OSC 1</p> <p>Connects a local oscillator coil of TV band</p>	<p>Approx. 10 kΩ</p> <p>Approx. V_{CC}</p>
14		<p>TV OSC 2</p> <p>Connects a local oscillator coil of TV band</p>	<p>Approx. 10 kΩ</p> <p>Approx. V_{CC}</p>
15		<p>OSC buff.</p> <p>Oscillator buffer output pin</p>	<p>Approx. 150 Ω</p> <p>Approx. $V_{CC} - 0.2$ V</p>
16		<p>FM OSC 1</p> <p>Connects a local oscillator coil of FM band</p>	<p>Approx. 10 kΩ</p> <p>Approx. V_{CC}</p>

■ Terminal Equivalent Circuits (continued)

Pin No.	Equivalent circuit	Description	Input resistance or pin voltage
17		<p>FM OSC 2</p> <p>Connects a local oscillator coil of FM band</p>	<p>Approx. 10 kΩ</p> <p>Approx. V_{CC}</p>
18		<p>TV RF</p> <p>Connects an RF tuning coil of TV band</p>	<p>—</p>
19		<p>FM RF</p> <p>Connects an RF tuning coil of FM band</p>	<p>—</p>
20	<p>—</p>	<p>V_{CC1}</p> <p>Power supply pin (RF, mix.block)</p>	<p>—</p>

■ Application Circuit Example

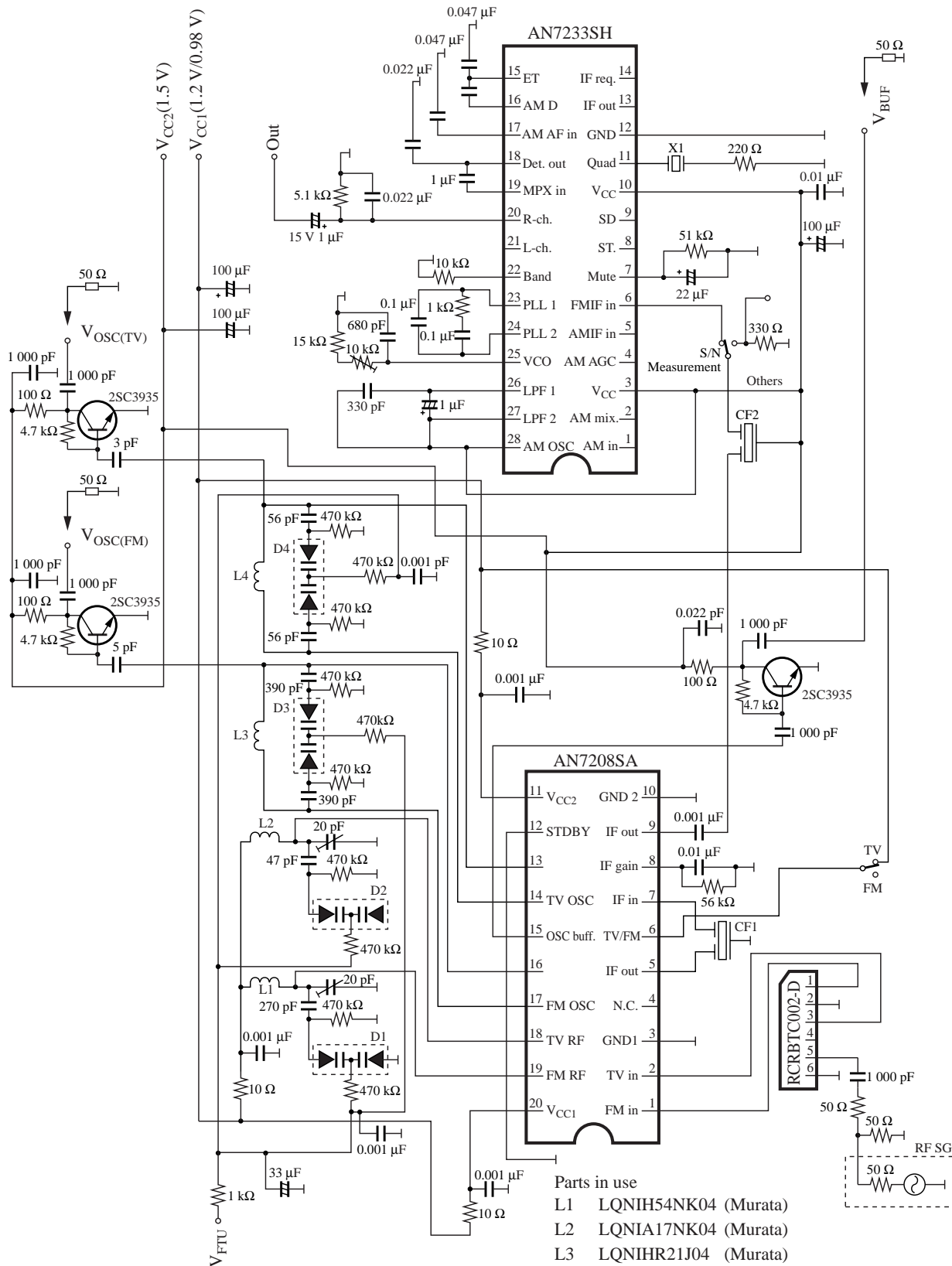

- Parts in use
- L1 LQNIH54NK04 (Murata)
 - L2 LQNI17NK04 (Murata)
 - L3 LQNIHR21J04 (Murata)
 - L4 LQNI133NK04 (Murata)
 - Vari-cap. RVDSVC203ATX (Sanyo)
 - CF1, CF2 RLFGFCWN04AL (Murata)
 - X1 RLFDCG01AL (Murata)