

High-Speed Transimpedance Amplifier

Description

CXA1527Q is a low noise amplifier, particularly suitable for signal recovery in fiber-optic receivers.

Features

- High-speed bipolar process provides for ultra high-speed operation
- High transimpedance $3k\Omega$ (Typ.)
- Wide band width 550MHz (Typ.)
- Low noise (at 10MHz) $2.8\text{pA}/\sqrt{\text{Hz}}$ (Typ.)
- Low power consumption 27mW (Typ.)
- Single power supply
- (Negative supply) $V_{CC}=V_{CCA}=\text{GND},$
 $V_{EE}=-5.2\text{V}$
- (Positive supply) $V_{CC}=V_{CCA}=+5.0\text{V},$
 $V_{EE}=\text{GND}$

Absolute Maximum Ratings ($V_{CC}=V_{CCA}$)

- Supply voltage $V_{CC}-V_{EE}$ -0.3 to $+7.0$ V
- Minimum input voltage V_{IN} $V_{EE}-2.0$ V
- Input voltage I_{IN} -250 to $+250$ μA
- Output current (continuous) I_O 0 to 50 mA
- Output current (surge) I_O 0 to 100 mA
- Operating case temperature T_C -55 to $+125$ $^{\circ}\text{C}$
- Storage temperature T_{stg} -65 to $+150$ $^{\circ}\text{C}$

Stresses greater than these conditions may cause permanent damage to the devices or affect their reliability.

Recommended Operating Conditions ($V_{CC}=V_{CCA}$)

- Supply voltage
- (Negative Supply) V_{EE} $V_{CC}=\text{GND}$ -5.46 to -4.94 V
- (Positive Supply) V_{CC} $V_{EE}=\text{GND}$ 4.5 to 5.5 V
- Operating case temperature T_C 0 to 85 $^{\circ}\text{C}$

The devices should be operated under these conditions, beyond which the parametric values are not specified.

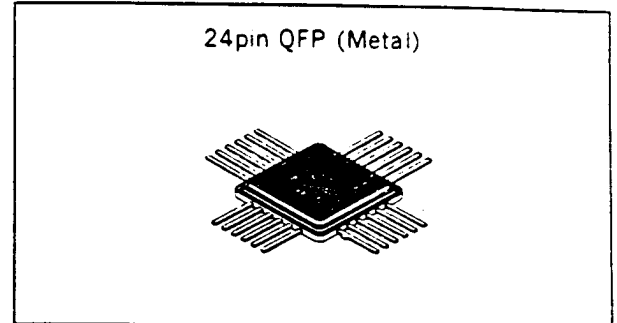

Application

- Fiber-optic receiver
- Instrument

Structure

Bipolar silicon monolithic IC

Sony reserves the right to change products and specifications without prior notice. This information does not convey any license by any implication or otherwise under any patents or other right. Application circuits shown, if any, are typical examples illustrating the operation of the devices. Sony cannot assume responsibility for any problems arising out of the use of these circuits.

Pin Assignment

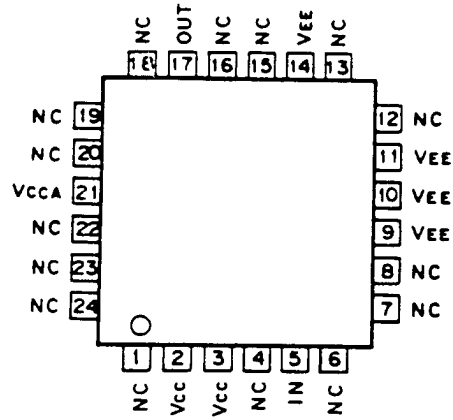

Pin Description

Pin No.	Symbol	Equivalent circuit	Description
5	IN		Data input
17	OUT		Data output
2, 3	Vcc		Positive power supply
21	VCCA		Positive power supply for output
9, 10 11, 14	VEE		Negative power supply
1, 4, 6, 7, 8, 12, 13, 14, 16, 18, 19, 20, 22, 23, 24	NC		No connection

DC Characteristics

($T_c=0$ to $+85^\circ\text{C}$, $V_{EE}=\text{GND}$, $V_{CC}=V_{CCA}=5\text{V} \pm 0.5\text{V}$, $R_L=300\Omega$)

Item	Symbol	Conditions	Min.	Typ.	Max.	Unit
Supply current	I_{EE}	Input pin left open *1	-4.0	-2.7	-1.6	mA
Transimpedance	Z_T	$I_{IN}=-140\ \mu\text{A}$ to $+140\ \mu\text{A}$	2.2	3.0	3.8	$\text{k}\Omega$
Maximum input current	I_{MAX}		140			μA
Input bias voltage	V_{IN}			$V_{EE}+0.77$		V
Output bias voltage	V_{OUT}	Input pin left open		$V_{EE}+0.98$		V
Input capacitance	C_{IN}			1.3		pF

*1: $P_D=|I_{EE}| \times 5.0\text{V} + V_{OUT}/R_L \times (5.0\text{V}-V_{OUT})$, see DC characteristics test circuit.

DC Characteristics Test Circuit

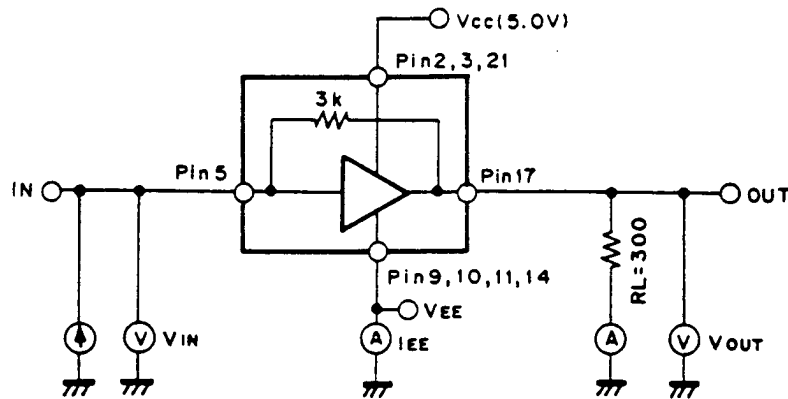

AC Characteristics

($T_c=0$ to 85°C , $V_{EE}=\text{GND}$, $V_{CC}=V_{CCA}=5.0\text{V} \pm 0.5\text{V}$)

Item	Symbol	Conditions	Min.	Typ.	Max.	Unit
Transimpedance	Z_T	$f_{in}=10\text{MHz}$	2.2	3.0	3.8	$\text{k}\Omega$
Bandwidth (-3dB)	f_{3dB}	*1, 2	450	550		MHz
Input current noise spectral density	I_n	$f_{in}=10\text{MHz}$		2.8		$\text{pA}/\sqrt{\text{Hz}}$

*1: Assumes photodiode capacitance. $C_{PD}=1\text{pF}$. Referenced from 10MHz.

*2: Circuit board layout dependent at higher frequencies. For best performance use RF filter in power supply lines.

AC Characteristics Test Circuit

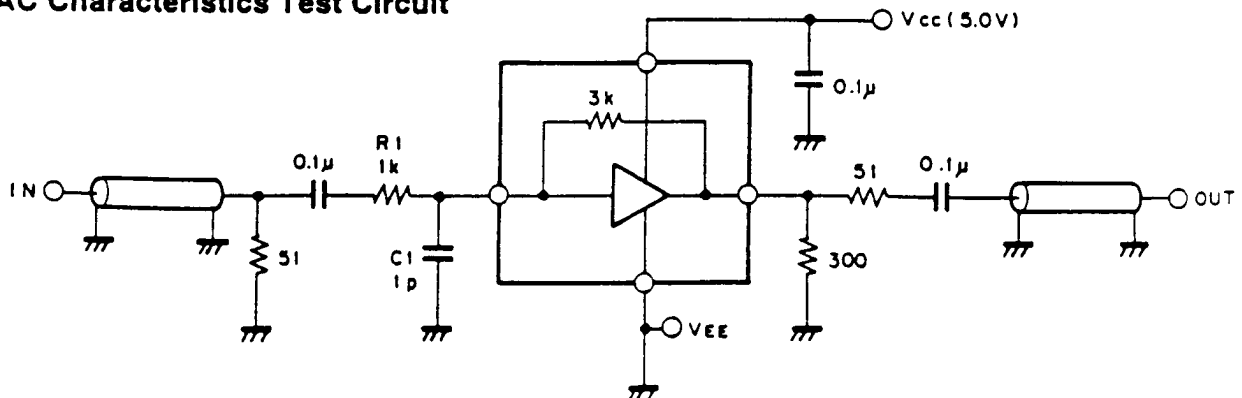

C1 : Assumes photodiode capacitance
R1 : For V - I conversion

Typical Performance (Ta=25°C, VEE=GND, VCC=VCCA=5.0V)

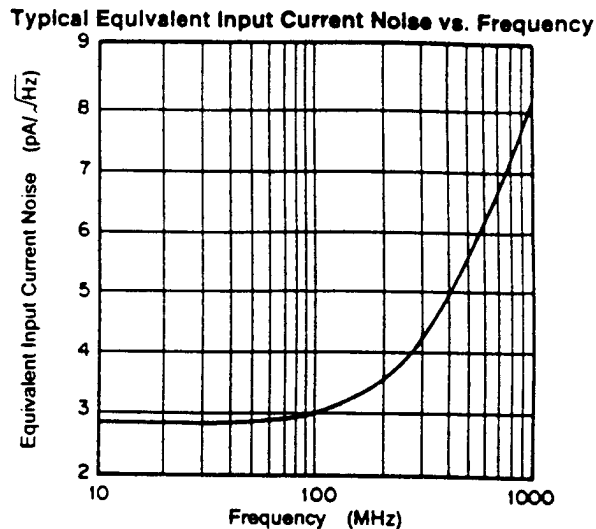
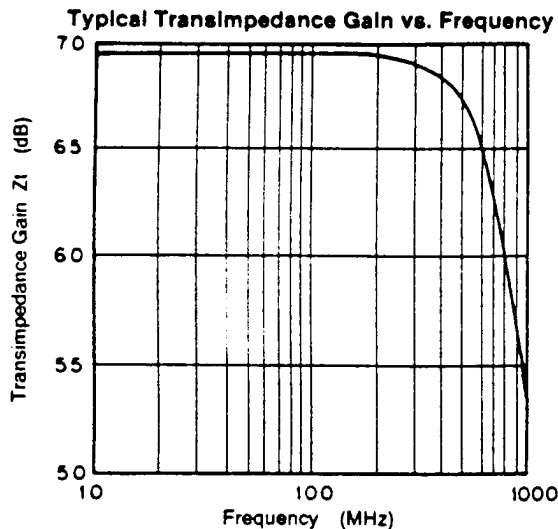

Application Circuit

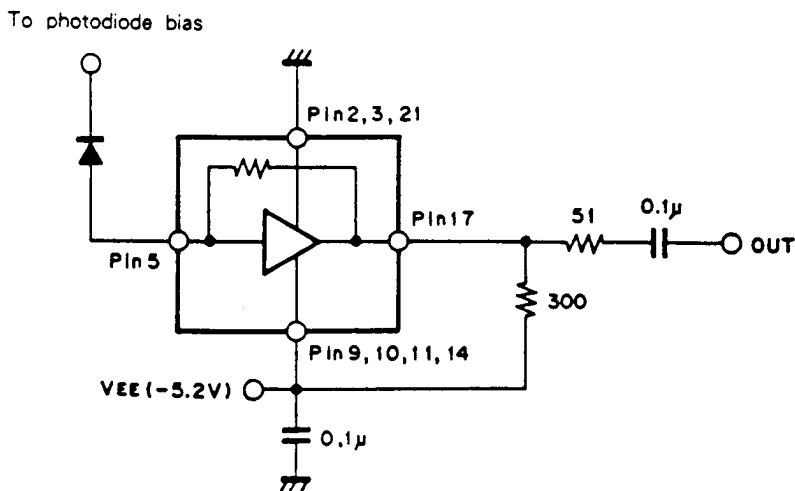

Application circuits shown are typical examples illustrating the operation of the devices. Sony cannot assume responsibility for any problems arising out of the use of these circuits or for any infringement of third party patent and other right due to same.

Cautions for Handling

1. As the electrostatic breakdown level is weak, take care to handle.
2. The internal resistor (R5=10kΩ) of the output pin (No. 17) does not have the capability of drive. The terminal resistor must be connected, and the resistance value should be selected between 100Ω and 300Ω.

Package Outline Unit : mm

24pin QFP (Metal) 0.3g

