

M51848L,P

SINGLE TIMER

DESCRIPTION

The M51848 are semiconductor integrated circuits designed for producing accurate timing pulse and time delay. The delay time can be set from microseconds through minutes by externally connected resistor and capacitor. In an astable multivibrator, the maximum frequency is 100kHz. The reset voltage is 1.4V typ. ($T_a=25^\circ\text{C}$), and compatible with TTL level.

FEATURES

- Timing from microseconds through minutes
- Wide range of unage as monostable or astable multivibrators
- Maximum oscillation frequency 100kHz
- Reset voltage is compatible with TTL level
- Built-in supply voltage reset circuit for setting the output in the low state, when power is supplied

APPLICATION

Monostable multivibrator, astable multivibrator, pulsewidth modulation

RECOMMENDED OPERATING CONDITION

Supply voltage range 4~17V

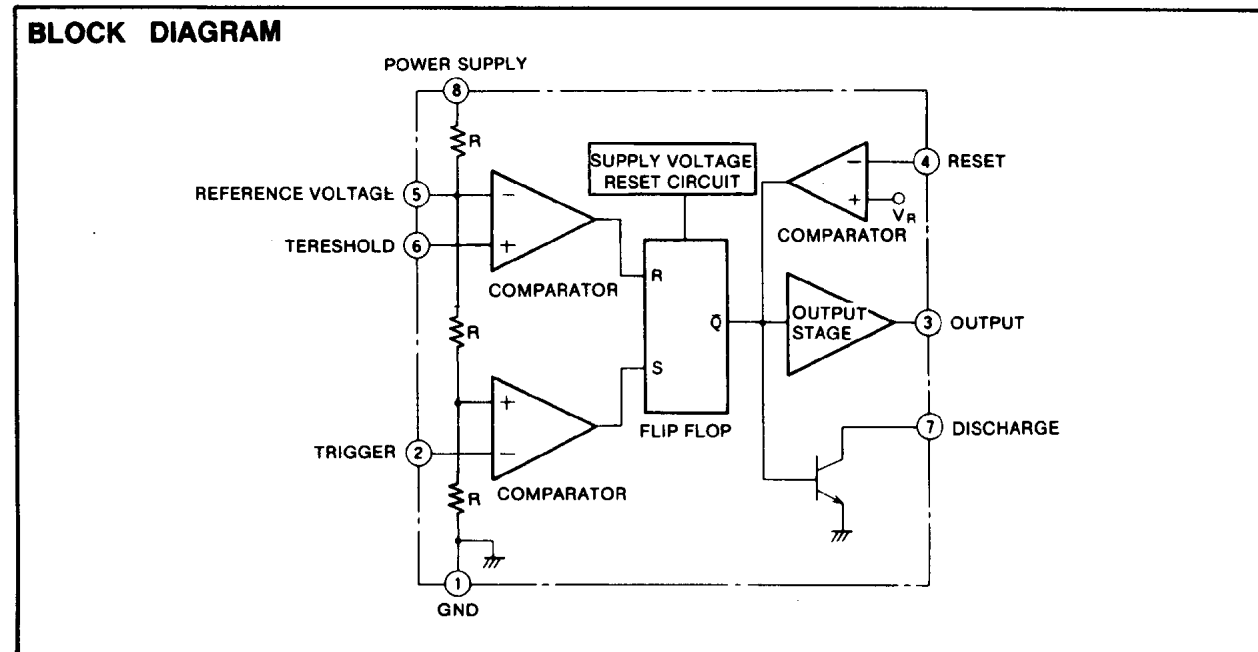
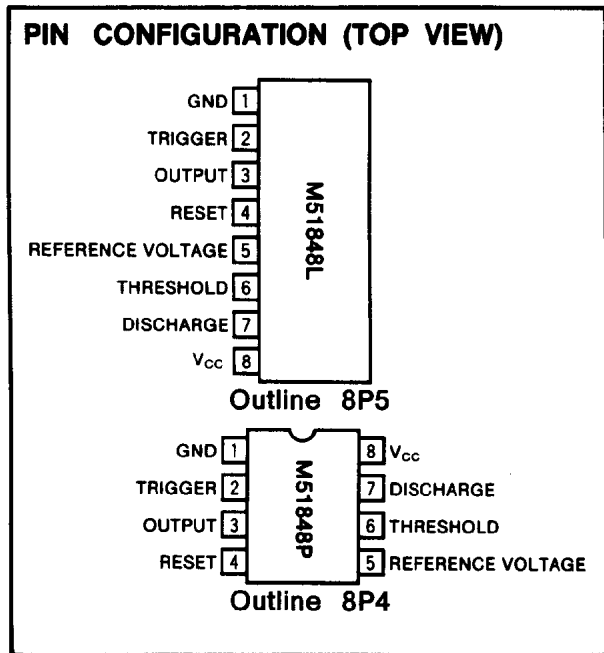

ABSOLUTE MAXIMUM RATINGS ($T_a=25^\circ\text{C}$, unless otherwise noted)

Symbol	Parameter	Conditions	Ratings	Unit
V_{CC}	Supply voltage		18	V
$I_{O(\text{peak})}$	Output current		200	mA
P_D	Power dissipation		360(M51848L)	mW
			625(M51848P)	
K_θ	Thermal derating	$T_a \geq 25^\circ\text{C}$	3.6(M51848L)	mW/°C
			6.25(M51848P)	
T_{opr}	Operating ambient temperature		-20~+75	°C
T_{stg}	Storage temperature		-40~+125	°C

ELECTRICAL CHARACTERISTICS ($T_a=25^\circ\text{C}$, $V_{CC}=15\text{V}$, unless otherwise noted)

Symbol	Parameter	Test conditions	Limits			Units
			Min	Typ	Max	
V_{CC}	Supply voltage		4		17	V
I_{CC}	Circuit current	$V_{CC}=5\text{V}, R_L=\infty$		3	5.5	mA
		$V_{CC}=15\text{V}, R_L=\infty$		7	10	
V_{REF}	Reference voltage	$V_{CC}=5\text{V}$	2.6	3.33	4.0	V
		$V_{CC}=15\text{V}$	9	10	11	
V_{TH}	Threshold voltage			$2/3V_{CC}$	V	
I_{TH}	Threshold current			0.05	0.3	μA
V_T	Trigger voltage			$1/3V_{CC}$	V	
I_T	Trigger current			0.1	0.5	μA
V_R	Reset voltage		1.0	1.4	2.0	V
I_R	Reset current			0.05	0.2	μA
V_{OL}	Low output voltage	$V_{CC}=5\text{V}, I_{\text{sink}}=5\text{mA}$		0.05	0.2	V
		$V_{CC}=15\text{V}, I_{\text{sink}}=10\text{mA}$		0.05	0.2	
		$V_{CC}=15\text{V}, I_{\text{sink}}=50\text{mA}$		0.2	0.5	
		$V_{CC}=15\text{V}, I_{\text{sink}}=100\text{mA}$		0.5	2.0	
V_{OH}	High output voltage	$V_{CC}=5\text{V}, I_{\text{source}}=100\text{mA}$	2.8	3.3		V
		$V_{CC}=15\text{V}, I_{\text{source}}=100\text{mA}$	12.8	13.3		
f_{max}	Maximum operating frequency	$R_A=R_B=2\text{k}\Omega, C_A=200\text{pF}$	100			kHz
—	Timing accuracy			0.5		%
—	Temperature coefficient			50		ppm/°C
—	Supply voltage rejection ratio			0.01		%/V
—	rise time			150		ns

TYPICAL CHARACTERISTICS ($T_a=25^\circ\text{C}$, unless otherwise noted)

THERMAL DERATING (MAXIMUM RATING)

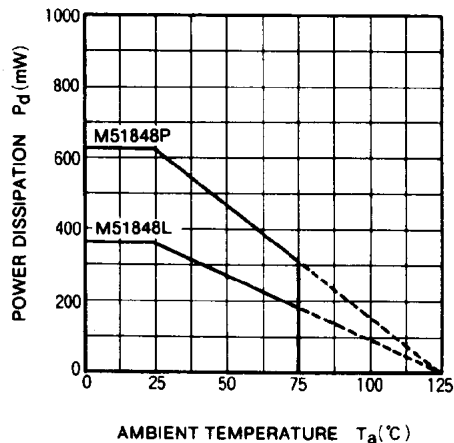

DELAY TIME VS. TIMING RESISTOR, CAPACITANCE

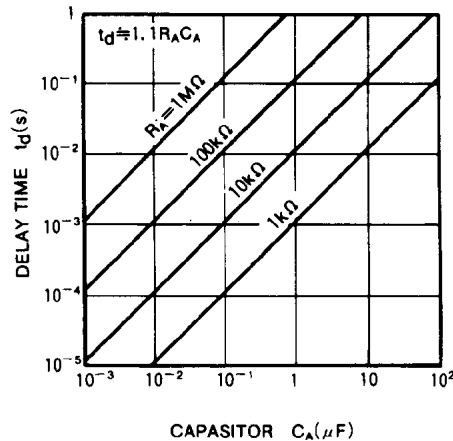

FREE RUNNING FREQUENCY VS. TIMING RESISTOR, CAPACITOR

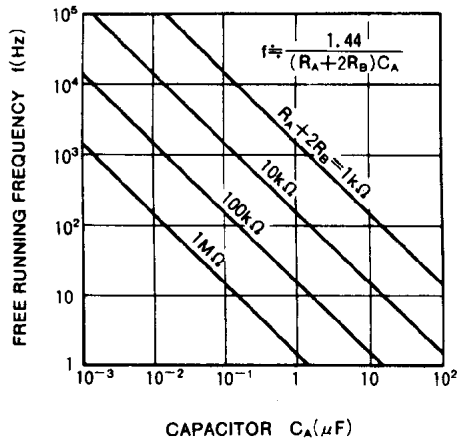

CIRCUIT CURRENT VS. SUPPLY VOLTAGE

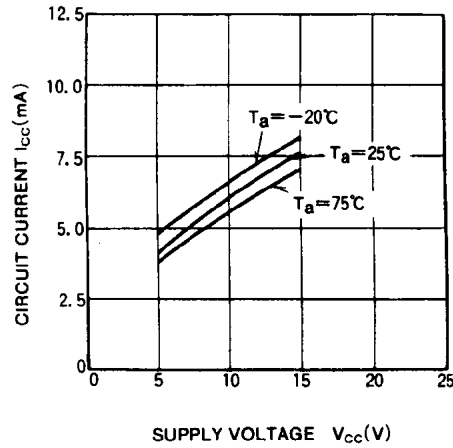

HIGH OUTPUT VOLTAGE VS. OUTPUT SOURCE CURRENT

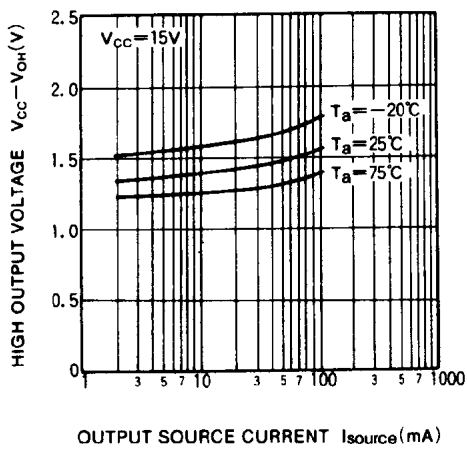

LOW OUTPUT VOLTAGE VS. OUTPUT SINK CURRENT

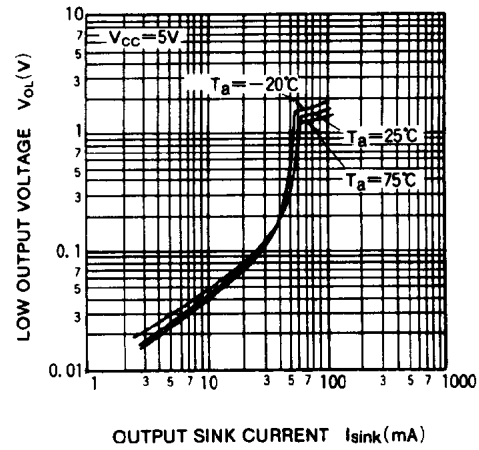

LOW OUTPUT VOLTAGE VS. OUTPUT SINK CURRENT

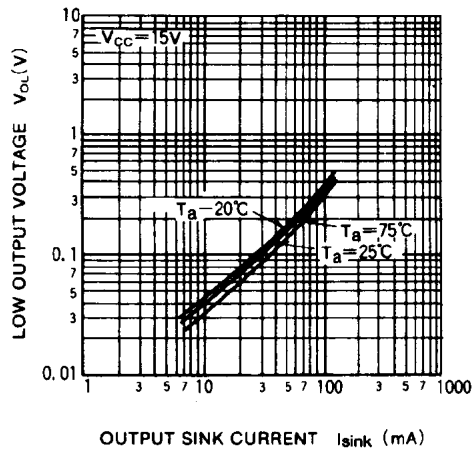

RESET VOLTAGE VS. SUPPLY VOLTAGE

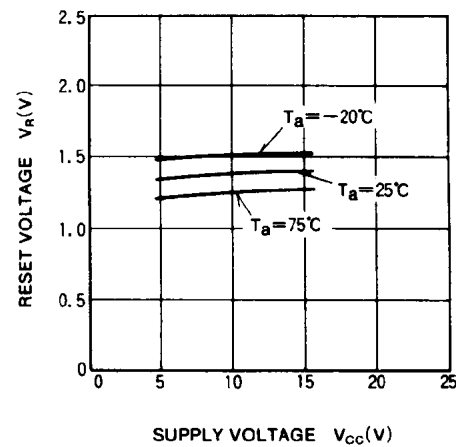

PIN DESCRIPTION

1. Trigger pin (pin ②)

When the voltage at the trigger pin is reduced to lower than $1/3V_{CC}$, timing operation is started. Once triggered, the voltage is not affected during operation by the trigger voltage.

2. Output pin (pin ③)

Logic output level is normally in the low state but is in the high state during timing operation. The output circuit is shaped like a totem-pole and withstands maximum load current of 200mA. The circuit can directly drive the TTL or DTL circuits.

3. Reset pin (pin ④)

Timing operation can be interrupted by applying the reset signal to a reset pin. (The voltage at this pin must be less than 1.4V.)

If the reset signal is applied, the output is in the low state and the reset condition is maintained as long as the signal is applied. The output stays in the low state until the reset signal is removed and the set signal (trigger signal at a trigger pin) is applied. Connect this pin to V_{CC} if not used.

4. Reference voltage pin (pin ⑤)

The voltage at this pin is normally set at $2/3V_{CC}$. By applying reference voltage, delay time or oscillation frequency can be changed. The control signal for pulse-width modulation is applied through this pin. Connect a capacitor of $0.01 \mu F$ between this pin and GND as noise filter, if the pin not used.

5. Threshold pin (pin ⑥)

The delay time is determined by CR time constants connected to this pin. The delay time of a monostable multivibrator t_d is expressed by the equation $t_d \approx 1.1R_A C_A$.

6. Discharge pin (pin ⑦)

The timing capacitor discharges at this pin. The discharge is enabled when a flip flop in the device is ON and the reset signal is applied. In a monostable multivibrator, the capacitor is connected to pin ⑥.

APPLICATION EXAMPLES

(1) Delay-timer (monostable multivibrator)

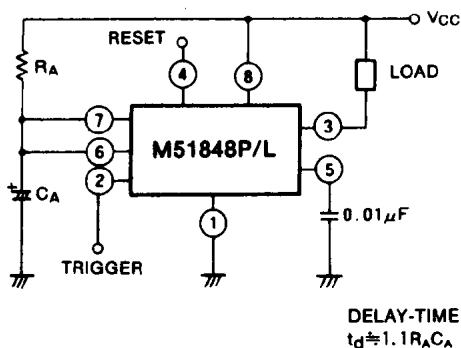

(2) Pulse oscillator (astable multivibrator)

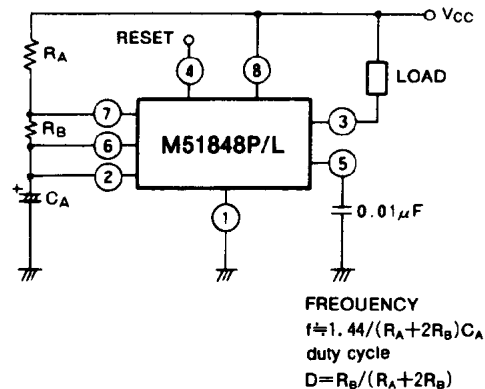

Precautions for us

1. Care must be taken not to connect the discharge pin (pin ⑦) directly to V_{CC} . Such connection causes short circuit of V_{CC} and GND through a discharge transistor (built into the device) and may destroy the integrated circuit.

2. Connect the reset pin (pin ④) to V_{CC} , if not used.

3. A capacitor connected to a reference voltage pin (pin ⑤) functions as the noise filter. Choose appropriate capacitance according to the noise induced. The M51843P is recommended for use in any environment where noise causes misoperation.