

**Glenair Connector
Designator F**

MIL-DTL-38999 Series I & II,
40M38277, PAN 6433-1, PATT
614, PATT 616,
NFC93422 Series HE308 &
HE309

M85049/33-2-10 W

Basic Part No.

Shell Size

Finish

N = Electroless Nickel

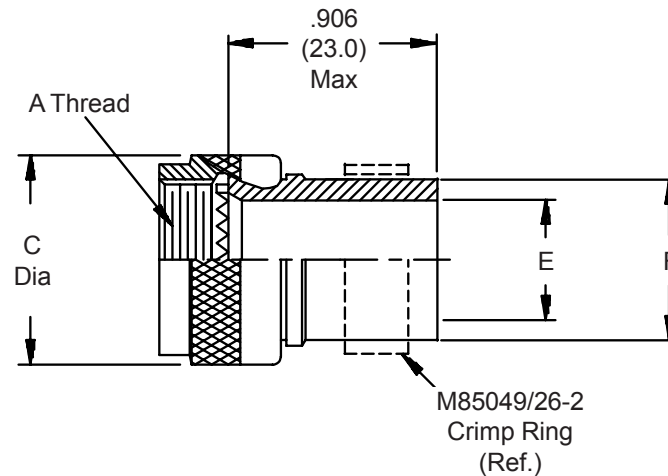
W = 1,000 hour Cadmium Olive Drab
Over Electroless Nickel
TABLE I

Shell Size	A Thread Class 2B	C Dia Max	E Dia	F Dia Max	M85049/26-2 Crimp Ring Ref.
08	.438 - 28 UNEF	.75 (19.1)	.250 (6.4)	.347 (8.8)	8
10	.562 - 24 UNEF	.85 (21.6)	.325 (8.3)	.498 (12.6)	10
12	.688 - 24 UNEF	1.00 (25.4)	.420 (10.7)	.510 (13.0)	12
14	.813 - 20 UNEF	1.10 (27.9)	.540 (13.7)	.630 (16.0)	14
16	.938 - 20 UNEF	1.25 (31.8)	.670 (17.0)	.760 (19.3)	16
18	1.063 - 18 UNEF	1.40 (35.6)	.789 (20.0)	.890 (22.6)	18
20	1.188 - 18 UNEF	1.50 (38.1)	.914 (23.2)	1.010 (25.7)	20
22	1.313 - 18 UNEF	1.65 (41.9)	1.039 (26.4)	1.130 (28.7)	22
24	1.438 - 18 UNEF	1.75 (44.5)	1.112 (28.2)	1.202 (30.5)	24

1. For complete dimensions see applicable Military Specification.
2. Metric dimensions (mm) are indicated in parentheses.