

# Am29LV640MH/L

Data Sheet



RETIRED  
PRODUCT

This product has been retired and is not available for designs. For new and current designs, S29GL064A supersedes Am29LV640M H/L and is the factory-recommended migration path. Please refer to the S29GL064A datasheet for specifications and ordering information. Availability of this document is retained for reference and historical purposes only.

April 2005

The following document specifies Spansion memory products that are now offered by both Advanced Micro Devices and Fujitsu. Although the document is marked with the name of the company that originally developed the specification, these products will be offered to customers of both AMD and Fujitsu.

## Continuity of Specifications

There is no change to this datasheet as a result of offering the device as a Spansion product. Any changes that have been made are the result of normal datasheet improvement and are noted in the document revision summary, where supported. Future routine revisions will occur when appropriate, and changes will be noted in a revision summary.

## For More Information

Please contact your local AMD or Fujitsu sales office for additional information about Spansion memory solutions.



**THIS PAGE LEFT INTENTIONALLY BLANK.**

# Am29LV640MH/L



## 64 Megabit (4 M x 16-Bit/8 M x 8-Bit) MirrorBit™ 3.0 Volt-only Uniform Sector Flash Memory with Versatile/O™ Control

This product has been retired and is not available for designs. For new and current designs, S29GL064A supersedes Am29LV640M H/L and is the factory-recommended migration path. Please refer to the S29GL064A datasheet for specifications and ordering information. Availability of this document is retained for reference and historical purposes only.

### DISTINCTIVE CHARACTERISTICS

#### ARCHITECTURAL ADVANTAGES

- **Single power supply operation**
  - 3 V for read, erase, and program operations
- **Versatile/O™ control**
  - Device generates data output voltages and tolerates data input voltages on the DQ inputs/outputs as determined by the voltage on the V<sub>IO</sub> pin; operates from 1.65 to 3.6 V
- **Manufactured on 0.23 μm MirrorBit process technology**
- **SecSi™ (Secured Silicon) Sector region**
  - 128-word/256-byte sector for permanent, secure identification through an 8-word/16-byte random Electronic Serial Number, accessible through a command sequence
  - May be programmed and locked at the factory or by the customer
- **Flexible sector architecture**
  - One hundred twenty-eight 32 Kword/64-Kbyte sectors
- **Compatibility with JEDEC standards**
  - Provides pinout and software compatibility for single-power supply flash, and superior inadvertent write protection
- **Minimum 100,000 erase cycle guarantee per sector**
- **20-year data retention at 125°C**

#### PERFORMANCE CHARACTERISTICS

- **High performance**
  - 90 ns access time
  - 25 ns page read times
  - 0.5 s typical sector erase time
  - 22 μs typical effective write buffer word programming time: 16-word/32-byte write buffer reduces overall programming time for multiple-word/byte updates

- 4-word/8-byte page read buffer
- 16-word/32-byte write buffer

- **Low power consumption (typical values at 3.0 V, 5 MHz)**

- 30 mA typical active read current
- 50 mA typical erase/program current
- 1 μA typical standby mode current

- **Package options**

- 56-pin TSOP
- 64-ball Fortified BGA

#### SOFTWARE FEATURES

- Program Suspend & Resume: read other sectors before programming operation is completed
- Erase Suspend & Resume: read/program other sectors before an erase operation is completed
- Data# polling & toggle bits provide status
- Unlock Bypass Program command reduces overall multiple-word programming time
- CFI (Common Flash Interface) compliant: allows host system to identify and accommodate multiple flash devices

#### HARDWARE FEATURES

- Sector Group Protection: hardware-level method of preventing write operations within a sector group
- Temporary Sector Unprotect: V<sub>IO</sub>-level method of changing code in locked sectors
- WP#/ACC input: Write Protect input (WP#) protects first or last sector regardless of sector protection settings ACC (high voltage) accelerates programming time for higher throughput during system production
- Hardware reset input (RESET#) resets device
- Ready/Busy# output (RY/BY#) indicates program or erase cycle completion

## GENERAL DESCRIPTION

The Am29LV640MH/L is a 64 Mbit, 3.0 volt single power supply flash memory device organized as 4,194,304 words or 8,388,608 bytes. The device has an 8-bit/16-bit bus and can be programmed either in the host system or in standard EPROM programmers.

An access time of 90, 100, 110, or 120 ns is available. Note that each access time has a specific operating voltage range ( $V_{CC}$ ) and an I/O voltage range ( $V_{IO}$ ), as specified in the [Product Selector Guide](#) and the [Ordering Information](#) sections. The device is offered in a 56-pin TSOP or 64-ball Fortified BGA package. Each device has separate chip enable (CE#), write enable (WE#) and output enable (OE#) controls.

Each device requires only a **single 3.0 volt power supply** for both read and write functions. In addition to a  $V_{CC}$  input, a high-voltage **accelerated program (ACC)** feature provides shorter programming times through increased current on the WP#/ACC input. This feature is intended to facilitate factory throughput during system production, but may also be used in the field if desired.

The device is entirely command set compatible with the **JEDEC single-power-supply Flash standard**. Commands are written to the device using standard microprocessor write timing. Write cycles also internally latch addresses and data needed for the programming and erase operations.

The **sector erase architecture** allows memory sectors to be erased and reprogrammed without affecting the data contents of other sectors. The device is fully erased when shipped from the factory.

Device programming and erasure are initiated through command sequences. Once a program or erase operation has begun, the host system need only poll the DQ7 (Data# Polling) or DQ6 (toggle) **status bits** or monitor the **Ready/Busy# (RY/BY#)** output to determine whether the operation is complete. To facilitate programming, an **Unlock Bypass** mode reduces command sequence overhead by requiring only two write cycles to program data instead of four.

The **VersatileI/O™** ( $V_{IO}$ ) control allows the host system to set the voltage levels that the device generates and tolerates on the CE# control input and DQ I/Os to

the same voltage level that is asserted on the  $V_{IO}$  pin. Refer to the [Ordering Information](#) section for valid  $V_{IO}$  options.

**Hardware data protection** measures include a low  $V_{CC}$  detector that automatically inhibits write operations during power transitions. The hardware sector protection feature disables both program and erase operations in any combination of sectors of memory. This can be achieved in-system or via programming equipment.

The **Erase Suspend/Erase Resume** feature allows the host system to pause an erase operation in a given sector to read or program any other sector and then complete the erase operation. The **Program Suspend/Program Resume** feature enables the host system to pause a program operation in a given sector to read any other sector and then complete the program operation.

The **hardware RESET# pin** terminates any operation in progress and resets the device, after which it is then ready for a new operation. The RESET# pin may be tied to the system reset circuitry. A system reset would thus also reset the device, enabling the host system to read boot-up firmware from the Flash memory device.

The device reduces power consumption in the **standby mode** when it detects specific voltage levels on CE# and RESET#, or when addresses have been stable for a specified period of time.

The **Write Protect (WP#)** feature protects the first or last sector by asserting a logic low on the WP#/ACC pin. The protected sector will still be protected even during accelerated programming.

The **SecSi™ (Secured Silicon) Sector** provides a 128-word/256-byte area for code or data that can be permanently protected. Once this sector is protected, no further changes within the sector can occur.

Spansion MirrorBit flash technology combines years of Flash memory manufacturing experience to produce the highest levels of quality, reliability and cost effectiveness. The device electrically erases all bits within a sector simultaneously via hot-hole assisted erase. The data is programmed using hot electron injection.

**MIRRORBIT 64 MBIT DEVICE FAMILY**

Device	Bus	Sector Architecture	Packages	V <sub>IO</sub>	RY/BY#	WP#, ACC	WP# Protection
LV065MU	x8	Uniform (64 Kbyte)	48-pin TSOP (std. & rev. pinout), 63-ball FBGA	Yes	Yes	ACC only	No WP#
LV640MT/B	x8/x16	Boot (8 x 8 Kbyte at top & bottom)	48-pin TSOP, 63-ball Fine-pitch BGA, 64-ball Fortified BGA	No	Yes	WP#/ACC pin	2 x 8 Kbyte top or bottom
LV640MH/L	x8/x16	Uniform (64 Kbyte)	56-pin TSOP (std. & rev. pinout), 64-ball Fortified BGA	Yes	Yes	WP#/ACC pin	1 x 64 Kbyte high or low
LV641MH/L	x16	Uniform (32 Kword)	48-pin TSOP (std. & rev. pinout)	Yes	No	Separate WP# and ACC pins	1 x 32 Kword top or bottom
LV640MU	x16	Uniform (32 Kword)	64-ball Fortified BGA, 64-Ball Fine-Pitch BGA	Yes	Yes	ACC only	No WP#

**Related Documents**

To download related documents, click on the following links or go to [www.amd.com](http://www.amd.com)→Flash Memory→Product Information→MirrorBit→Flash Information→Technical Documentation.

[MirrorBit™ Flash Memory Write Buffer Programming and Page Buffer Read](#)

[Implementing a Common Layout for AMD MirrorBit and Intel StrataFlash Memory Devices](#)

[Migrating from Single-byte to Three-byte Device IDs](#)

[AMD MirrorBit™ White Paper](#)

## TABLE OF CONTENTS

<b>Product Selector Guide</b> .....	<b>5</b>	Erase Suspend/Erase Resume Commands .....	<b>32</b>
<b>Block Diagram</b> .....	<b>5</b>	Command Definitions .....	<b>33</b>
<b>Connection Diagrams</b> .....	<b>6</b>	Command Definitions (x16 Mode, BYTE# = V <sub>IH</sub> ) .....	<b>33</b>
<b>Pin Description</b> .....	<b>8</b>	Command Definitions (x8 Mode, BYTE# = V <sub>IL</sub> ) .....	<b>34</b>
<b>Logic Symbol</b> .....	<b>8</b>	<b>Write Operation Status</b> .....	<b>35</b>
<b>Ordering Information</b> .....	<b>9</b>	DQ7: Data# Polling .....	<b>35</b>
<b>Device Bus Operations</b> .....	<b>10</b>	Figure 8. Data# Polling Algorithm .....	<b>36</b>
Table 1. Device Bus Operations .....	10	RY/BY#: Ready/Busy# .....	<b>37</b>
Word/Byte Configuration .....	11	DQ6: Toggle Bit I .....	<b>37</b>
VersatileIO™ (V <sub>IO</sub> ) Control .....	11	Figure 9. Toggle Bit Algorithm .....	<b>38</b>
Requirements for Reading Array Data .....	11	DQ2: Toggle Bit II .....	<b>38</b>
Page Mode Read .....	11	Reading Toggle Bits DQ6/DQ2 .....	<b>39</b>
Writing Commands/Command Sequences .....	11	DQ5: Exceeded Timing Limits .....	<b>39</b>
Write Buffer .....	11	DQ3: Sector Erase Timer .....	<b>39</b>
Accelerated Program Operation .....	11	DQ1: Write-to-Buffer Abort .....	<b>39</b>
Autoselect Functions .....	12	Table 10. Write Operation Status .....	<b>40</b>
Standby Mode .....	12	<b>Absolute Maximum Ratings</b> .....	<b>41</b>
Automatic Sleep Mode .....	12	Figure 10. Maximum Negative Overshoot Waveform .....	<b>41</b>
RESET#: Hardware Reset Pin .....	12	Figure 11. Maximum Positive	
Output Disable Mode .....	12	Overshoot Waveform .....	<b>41</b>
Autoselect Mode .....	16	<b>Operating Ranges</b> .....	<b>41</b>
Table 2. Autoselect Codes, (High Voltage Method) .....	16	<b>DC Characteristics</b> .....	<b>42</b>
Sector Group Protection and Unprotection .....	16	<b>Test Conditions</b> .....	<b>43</b>
Table 3. Sector Group Protection/Unprotection Address Table .....	16	Figure 12. Test Setup .....	<b>43</b>
Write Protect (WP#) .....	18	Table 1. Test Specifications .....	<b>43</b>
Temporary Sector Group Unprotect .....	18	<b>Key to Switching Waveforms</b> .....	<b>43</b>
Figure 1. Temporary Sector Group Unprotect Operation .....	18	Figure 13. Input Waveforms and	
Figure 2. In-System Sector Group		Measurement Levels .....	<b>43</b>
Protect/Unprotect Algorithms .....	19	<b>AC Characteristics</b> .....	<b>44</b>
SecSi (Secured Silicon) Sector Flash Memory Region .....	20	Read-Only Operations .....	<b>44</b>
Figure 3. SecSi Sector Protect Verify .....	21	Figure 14. Read Operation Timings .....	<b>44</b>
Hardware Data Protection .....	21	Figure 15. Page Read Timings .....	<b>45</b>
Low VCC Write Inhibit .....	21	Hardware Reset (RESET#) .....	<b>46</b>
Write Pulse “Glitch” Protection .....	21	Figure 16. Reset Timings .....	<b>46</b>
Logical Inhibit .....	21	Erase and Program Operations .....	<b>47</b>
Power-Up Write Inhibit .....	21	Figure 17. Program Operation Timings .....	<b>48</b>
<b>Common Flash Memory Interface (CFI)</b> .....	<b>21</b>	Figure 18. Accelerated Program Timing Diagram .....	<b>48</b>
CFI Query Identification String .....	22	Figure 19. Chip/Sector Erase Operation Timings .....	<b>49</b>
System Interface String .....	22	Figure 20. Data# Polling Timings	
Table 6. Device Geometry Definition .....	23	(During Embedded Algorithms) .....	<b>50</b>
Table 7. Primary Vendor-Specific Extended Query .....	24	Figure 21. Toggle Bit Timings (During Embedded Algorithms) .....	<b>51</b>
<b>Command Definitions</b> .....	<b>24</b>	Figure 22. DQ2 vs. DQ6 .....	<b>51</b>
Reading Array Data .....	24	Temporary Sector Unprotect .....	<b>52</b>
Reset Command .....	25	Figure 23. Temporary Sector Group Unprotect Timing Diagram .....	<b>52</b>
Autoselect Command Sequence .....	25	Figure 24. Sector Group Protect and Unprotect Timing Diagram .....	<b>53</b>
Enter SecSi Sector/Exit SecSi Sector Command Sequence .....	25	Alternate CE# Controlled Erase and Program Operations .....	<b>54</b>
Word/Byte Program Command Sequence .....	25	Figure 25. Alternate CE# Controlled Write (Erase/Program)	
Unlock Bypass Command Sequence .....	26	Operation Timings .....	<b>55</b>
Write Buffer Programming .....	26	<b>Erase And Programming Performance</b> .....	<b>56</b>
Accelerated Program .....	27	<b>Latchup Characteristics</b> .....	<b>56</b>
Figure 4. Write Buffer Programming Operation .....	28	<b>TSOP Pin and BGA Package Capacitance</b> .....	<b>56</b>
Figure 5. Program Operation .....	29	<b>Data Retention</b> .....	<b>56</b>
Program Suspend/Program Resume Command Sequence .....	29	<b>Physical Dimensions</b> .....	<b>57</b>
Figure 6. Program Suspend/Program Resume .....	30	TS056/TSR056—56-Pin Standard and Reverse Pinout	
Chip Erase Command Sequence .....	30	Thin Small Outline Package (TSOP) .....	<b>57</b>
Sector Erase Command Sequence .....	30	LAA064—64-Ball Fortified Ball Grid Array (FBGA) 13 x 11 mm	
Figure 7. Erase Operation .....	31	Package .....	<b>58</b>
		<b>Revision Summary</b> .....	<b>59</b>

**PRODUCT SELECTOR GUIDE**

Part Number		Am29LV640MH/L					
Speed Option	$V_{CC} = 3.0-3.6\text{ V}$	<b>90R</b> ( $V_{IO} = 3.0-3.6\text{ V}$ )	<b>101R</b> ( $V_{IO} = 2.7-3.6\text{ V}$ )	<b>112R</b> ( $V_{IO} = 1.65-3.6\text{ V}$ )		<b>120R</b> ( $V_{IO} = 1.65-3.6\text{ V}$ )	
	$V_{CC} = 2.7-3.6\text{ V}$		<b>101</b> ( $V_{IO} = 2.7-3.6\text{ V}$ )	<b>112</b> ( $V_{IO} = 1.65-3.6\text{ V}$ )		<b>120</b> ( $V_{IO} = 1.65-3.6\text{ V}$ )	
Max. Access Time (ns)		90	100	110		120	
Max. CE# Access Time (ns)		90	100	110		120	
Max. Page access time ( $t_{PACC}$ )		25	30	30	40	30	40
Max. OE# Access Time (ns)		25	30	30	40	30	40

**Notes:**

1. See "AC Characteristics" for full specifications.
2. For the Am29LV640MH-L device, the last numeric digit in the speed option (e.g. 101, 112, 120) is used for internal purposes only. Please use OPNs as listed on p. 9 when placing orders.

**BLOCK DIAGRAM**

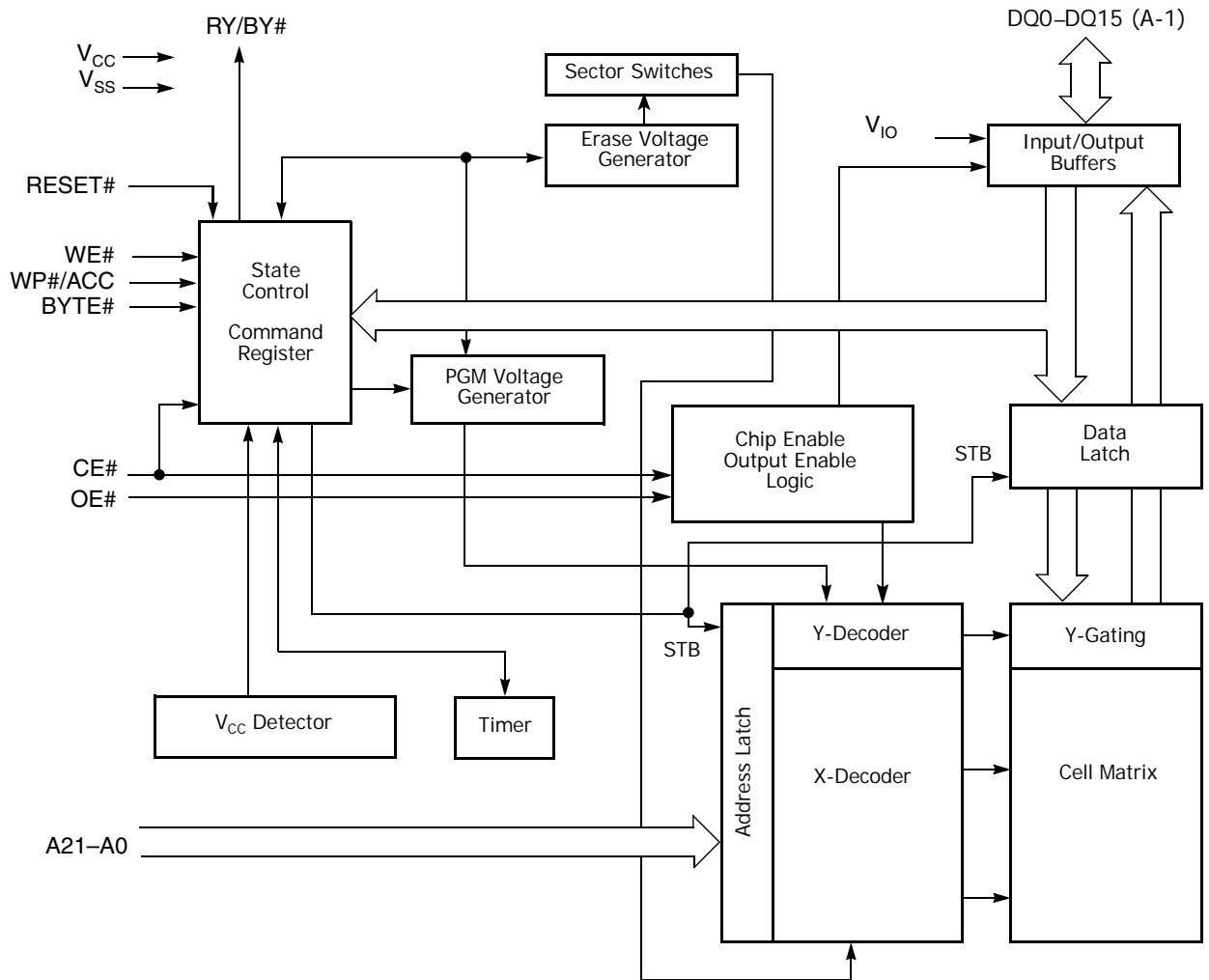

CONNECTION DIAGRAMS

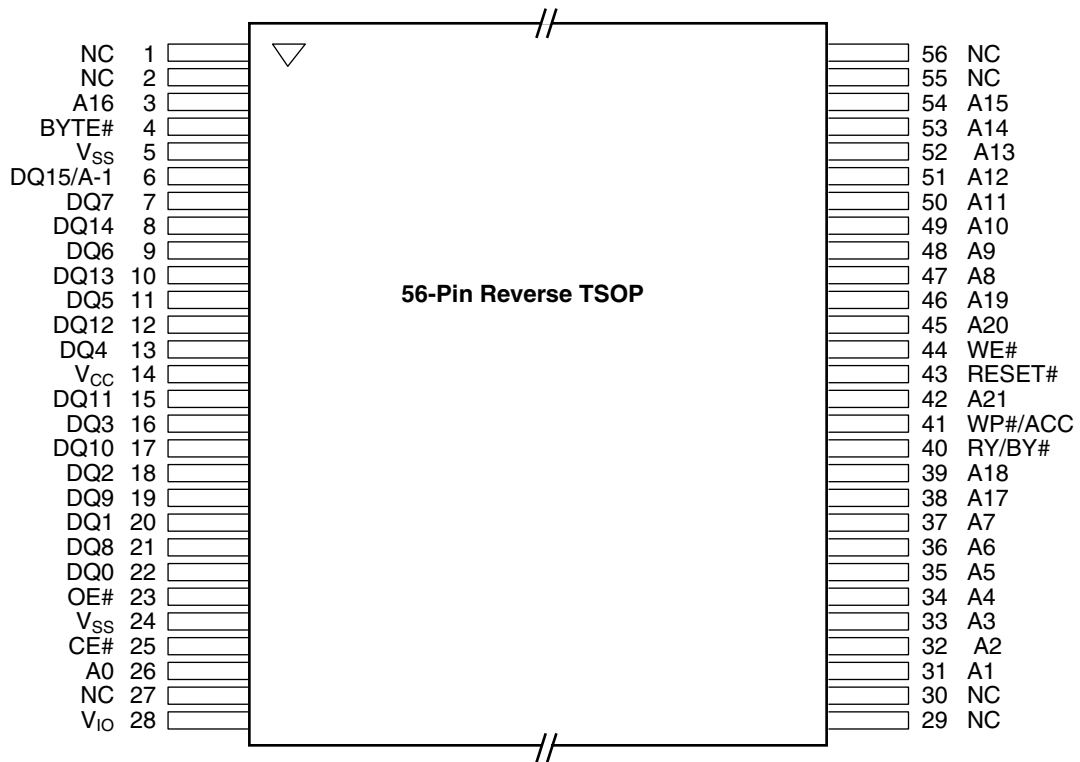
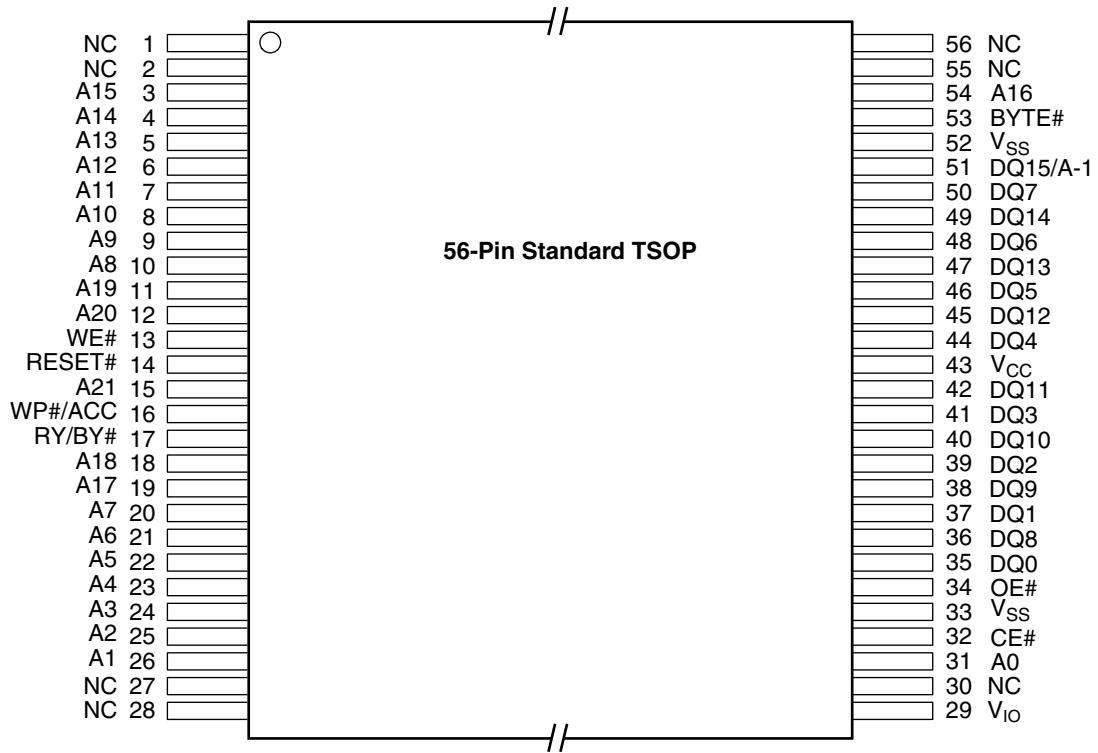





**PIN DESCRIPTION**

A21–A0	= 22 Address inputs	RESET#	= Hardware Reset Pin input
DQ14–DQ0	= 15 Data inputs/outputs	RY/BY#	= Ready/Busy output
DQ15/A-1	= DQ15 (Data input/output, word mode), A-1 (LSB Address input, byte mode)	BYTE#	= Selects 8-bit or 16-bit mode
CE#	= Chip Enable input	V <sub>CC</sub>	= 3.0 volt-only single power supply (see Product Selector Guide for speed options and voltage supply tolerances)
OE#	= Output Enable input	V <sub>IO</sub>	= Output Buffer power
WE#	= Write Enable input	V <sub>SS</sub>	= Device Ground
WP#/ACC	= Hardware Write Protect input/Pro- gramming Acceleration input	NC	= Pin Not Connected Internally

**Logic Symbol**

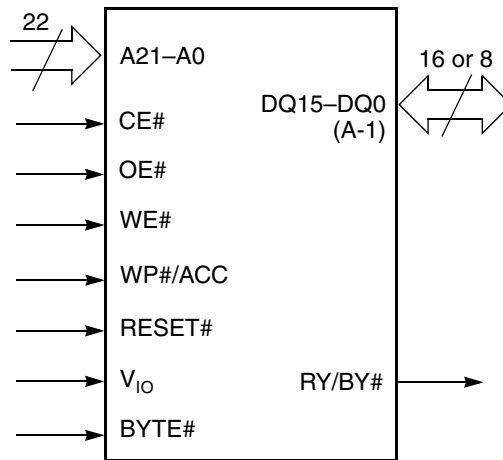

## ORDERING INFORMATION

### Standard Products

Standard products are available in several packages and operating ranges. The order number (Valid Combination) is formed by a combination of the following:

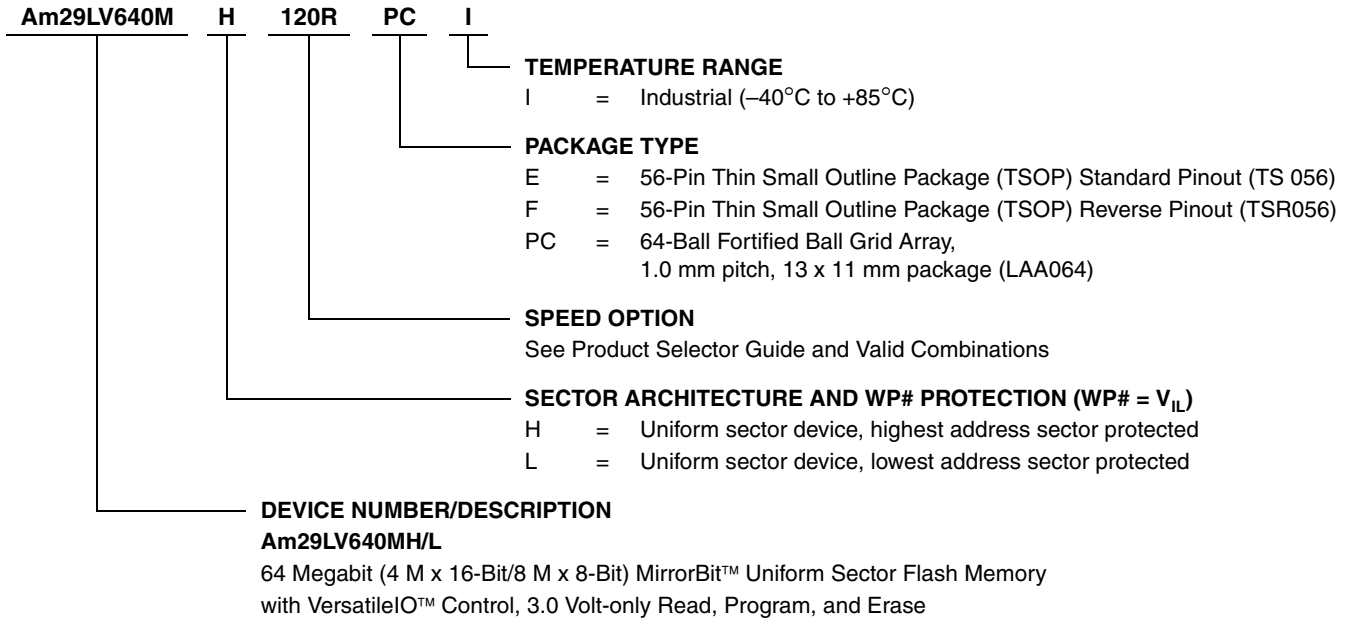

Valid Combinations for TSOP Package (Note 2)	Speed (ns)	V <sub>IO</sub> Range (V)	V <sub>CC</sub> Range (V)
Am29LV640MH90R Am29LV640ML90R	90	3.0–3.6	3.0–3.6
Am29LV640MH112 Am29LV640ML112	110	1.65–3.6	2.7–3.6
Am29LV640MH120 Am29LV640ML120	120	1.65–3.6	
Am29LV640MH101R Am29LV640ML101R	100	2.7–3.6	3.0–3.6
Am29LV640MH112R Am29LV640ML112R	110	1.65–3.6	
Am29LV640MH120R Am29LV640ML120R	120	1.65–3.6	

Valid Combinations for Fortified BGA Package (Note 2)		Speed (ns)	V <sub>IO</sub> Range (V)	V <sub>CC</sub> Range (V)
Order Number	Package Marking			
Am29LV640MH90R Am29LV640ML90R	L640MH90NI L640ML90NI	90	3.0–3.6	3.0–3.6
Am29LV640MH101 Am29LV640ML101	L640MH01PI L640ML01PI	100	2.7–3.6	2.7–3.6
Am29LV640MH112 Am29LV640ML112	L640MH11PI L640ML11PI	110	1.65–3.6	
Am29LV640MH120 Am29LV640ML120	L640MH12PI L640ML12PI	120	1.65–3.6	3.0–3.6
Am29LV640MH101R Am29LV640ML101R	L640MH01NI L640ML01NI	100	2.7–3.0	
Am29LV640MH112R Am29LV640ML112R	L640MH11NI L640ML11NI	110	1.65–3.6	
Am29LV640MH120R Am29LV640ML120R	L640MH12NI L640ML12NI	120	1.65–3.6	

### Valid Combinations

Valid Combinations list configurations planned to be supported in volume for this device. Consult the local AMD sales office to confirm availability of specific valid combinations and to check on newly released combinations.

#### Notes:

- For the Am29LV640MH-L device, the last numeric digit in the speed option (e.g. 101, 112, 120) is used for internal purposes only.
- To select product with ESN factory-locked into the SecSi Sector:
  - select order number from the valid combinations given above,
  - add designator "N" at the end of the order number, and 3) modify the speed option indicator as follows [101R = 10R, 112R = 11R, 120R = 12R, 90R, 101, 112, 120 = no change] Example: Am29LV640MH12RPCIN. For Fortified BGA packages, the designator "N" will also appear at the end of the package marking. Example: L640MH12NIN.

## DEVICE BUS OPERATIONS

This section describes the requirements and use of the device bus operations, which are initiated through the internal command register. The command register itself does not occupy any addressable memory location. The register is a latch used to store the commands, along with the address and data information needed to execute the command. The contents of the

register serve as inputs to the internal state machine. The state machine outputs dictate the function of the device. Table 1 lists the device bus operations, the inputs and control levels they require, and the resulting output. The following subsections describe each of these operations in further detail.

**Table 1. Device Bus Operations**

Operation	CE#	OE#	WE#	RESET#	WP#	ACC	Addresses (Note 2)	DQ0– DQ7	DQ8–DQ15	
									BYTE# = V <sub>IH</sub>	BYTE# = V <sub>IL</sub>
Read	L	L	H	H	X	X	A <sub>IN</sub>	D <sub>OUT</sub>	D <sub>OUT</sub>	DQ8–DQ14 = High-Z, DQ15 = A-1
Write (Program/Erase)	L	H	L	H	(Note 3)	X	A <sub>IN</sub>	(Note 4)	(Note 4)	
Accelerated Program	L	H	L	H	(Note 3)	V <sub>HH</sub>	A <sub>IN</sub>	(Note 4)	(Note 4)	
Standby	V <sub>CC</sub> ± 0.3 V	X	X	V <sub>CC</sub> ± 0.3 V	X	H	X	High-Z	High-Z	High-Z
Output Disable	L	H	H	H	X	X	X	High-Z	High-Z	High-Z
Reset	X	X	X	L	X	X	X	High-Z	High-Z	High-Z
Sector Group Protect (Note 2)	L	H	L	V <sub>ID</sub>	H	X	SA, A6=L, A3=L, A2=L, A1=H, A0=L	(Note 4)	X	X
Sector Group Unprotect (Note 2)	L	H	L	V <sub>ID</sub>	H	X	SA, A6=H, A3=L, A2=L, A1=H, A0=L	(Note 4)	X	X
Temporary Sector Group Unprotect	X	X	X	V <sub>ID</sub>	H	X	A <sub>IN</sub>	(Note 4)	(Note 4)	High-Z

**Legend:** L = Logic Low = V<sub>IL</sub>, H = Logic High = V<sub>IH</sub>, V<sub>ID</sub> = 11.5–12.5 V, V<sub>HH</sub> = 11.5–12.5 V, X = Don't Care, SA = Sector Address, A<sub>IN</sub> = Address In, D<sub>IN</sub> = Data In, D<sub>OUT</sub> = Data Out

### Notes:

- Addresses are A21:A0 in word mode; A21:A-1 in byte mode. Sector addresses are A21:A15 in both modes.
- The sector protect and sector unprotect functions may also be implemented via programming equipment. See the "Sector Group Protection and Unprotection" section.
- If WP# = V<sub>IL</sub>, the first or last sector remains protected. If WP# = V<sub>IH</sub>, the first or last sector will be protected or unprotected as determined by the method described in "Sector Group Protection and Unprotection". All sectors are unprotected when shipped from the factory (The SecSi Sector may be factory protected depending on version ordered.)
- D<sub>IN</sub> or D<sub>OUT</sub> as required by command sequence, data polling, or sector protect algorithm (see Figure 2).

## Word/Byte Configuration

The BYTE# pin controls whether the device data I/O pins operate in the byte or word configuration. If the BYTE# pin is set at logic '1', the device is in word configuration, DQ0–DQ15 are active and controlled by CE# and OE#.

If the BYTE# pin is set at logic '0', the device is in byte configuration, and only data I/O pins DQ0–DQ7 are active and controlled by CE# and OE#. The data I/O pins DQ8–DQ14 are tri-stated, and the DQ15 pin is used as an input for the LSB (A-1) address function.

## VersatileIO™ (V<sub>IO</sub>) Control

The **VersatileIO™** (V<sub>IO</sub>) control allows the host system to set the voltage levels that the device generates and tolerates on CE# and DQ I/Os to the same voltage level that is asserted on V<sub>IO</sub>. See “[Ordering Information](#)” on page 9 for V<sub>IO</sub> options on this device.

For example, a V<sub>IO</sub> of 1.65–3.6 volts allows for I/O at the 1.8 or 3 volt levels, driving and receiving signals to and from other 1.8 or 3 V devices on the same data bus.

## Requirements for Reading Array Data

To read array data from the outputs, the system must drive the CE# and OE# pins to V<sub>IL</sub>. CE# is the power control and selects the device. OE# is the output control and gates array data to the output pins. WE# should remain at V<sub>IH</sub>.

The internal state machine is set for reading array data upon device power-up, or after a hardware reset. This ensures that no spurious alteration of the memory content occurs during the power transition. No command is necessary in this mode to obtain array data. Standard microprocessor read cycles that assert valid addresses on the device address inputs produce valid data on the device data outputs. The device remains enabled for read access until the command register contents are altered.

See “[Reading Array Data](#)” for more information. Refer to the AC [Read-Only Operations](#) table for timing specifications and to Figure 14 for the timing diagram. Refer to the DC Characteristics table for the active current specification on reading array data.

## Page Mode Read

The device is capable of fast page mode read and is compatible with the page mode Mask ROM read operation. This mode provides faster read access speed for random locations within a page. The page size of the device is 4 words/8 bytes. The appropriate page is selected by the higher address bits A(max)–A2. Address bits A1–A0 in word mode (A1–A-1 in byte mode) determine the specific word within a page. This is an

asynchronous operation; the microprocessor supplies the specific word location.

The random or initial page access is equal to t<sub>ACC</sub> or t<sub>CE</sub> and subsequent page read accesses (as long as the locations specified by the microprocessor falls within that page) is equivalent to t<sub>PACC</sub>. When CE# is deasserted and reasserted for a subsequent access, the access time is t<sub>ACC</sub> or t<sub>CE</sub>. Fast page mode accesses are obtained by keeping the “read-page addresses” constant and changing the “intra-read page” addresses.

## Writing Commands/Command Sequences

To write a command or command sequence (which includes programming data to the device and erasing sectors of memory), the system must drive WE# and CE# to V<sub>IL</sub>, and OE# to V<sub>IH</sub>.

The device features an **Unlock Bypass** mode to facilitate faster programming. Once the device enters the Unlock Bypass mode, only two write cycles are required to program a word or byte, instead of four. The “[Word/Byte Program Command Sequence](#)” section has details on programming data to the device using both standard and Unlock Bypass command sequences.

An erase operation can erase one sector, multiple sectors, or the entire device. [Table 2](#) indicates the address space that each sector occupies.

Refer to the DC Characteristics table for the active current specification for the write mode. The [AC Characteristics](#) section contains timing specification tables and timing diagrams for write operations.

## Write Buffer

Write Buffer Programming allows the system to write a maximum of 16 words/32 bytes in one programming operation. This results in faster effective programming time than the standard programming algorithms. See “[Write Buffer](#)” for more information.

## Accelerated Program Operation

The device offers accelerated program operations through the ACC function. This is one of two functions provided by the WP#/ACC pin. This function is primarily intended to allow faster manufacturing throughput at the factory.

If the system asserts V<sub>HH</sub> on this pin, the device automatically enters the aforementioned Unlock Bypass mode, temporarily unprotects any protected sectors, and uses the higher voltage on the pin to reduce the time required for program operations. The system would use a two-cycle program command sequence as required by the Unlock Bypass mode. Removing V<sub>HH</sub> from the WP#/ACC pin returns the device to normal operation. *Note that the WP#/ACC pin must not be*

at  $V_{HH}$  for operations other than accelerated programming, or device damage may result. In addition, no external pullup is necessary since the WP#/ACC pin has internal pullup to  $V_{CC}$ .

### Autoselect Functions

If the system writes the autoselect command sequence, the device enters the autoselect mode. The system can then read autoselect codes from the internal register (which is separate from the memory array) on DQ7–DQ0. Standard read cycle timings apply in this mode. Refer to the [Autoselect Mode](#) and [Autoselect Command Sequence](#) sections for more information.

### Standby Mode

When the system is not reading or writing to the device, it can place the device in the standby mode. In this mode, current consumption is greatly reduced, and the outputs are placed in the high impedance state, independent of the OE# input.

The device enters the CMOS standby mode when the CE# and RESET# pins are both held at  $V_{IO} \pm 0.3$  V. (Note that this is a more restricted voltage range than  $V_{IH}$ .) If CE# and RESET# are held at  $V_{IH}$ , but not within  $V_{IO} \pm 0.3$  V, the device will be in the standby mode, but the standby current will be greater. The device requires standard access time ( $t_{CE}$ ) for read access when the device is in either of these standby modes, before it is ready to read data.

If the device is deselected during erasure or programming, the device draws active current until the operation is completed.

Refer to the [DC Characteristics](#) table for the standby current specification.

### Automatic Sleep Mode

The automatic sleep mode minimizes Flash device energy consumption. The device automatically enables

this mode when addresses remain stable for  $t_{ACC} + 30$  ns. The automatic sleep mode is independent of the CE#, WE#, and OE# control signals. Standard address access timings provide new data when addresses are changed. While in sleep mode, output data is latched and always available to the system. Refer to the [DC Characteristics](#) table for the automatic sleep mode current specification.

### RESET#: Hardware Reset Pin

The RESET# pin provides a hardware method of resetting the device to reading array data. When the RESET# pin is driven low for at least a period of  $t_{RP}$ , the device immediately terminates any operation in progress, tristates all output pins, and ignores all read/write commands for the duration of the RESET# pulse. The device also resets the internal state machine to reading array data. The operation that was interrupted should be reinitiated once the device is ready to accept another command sequence, to ensure data integrity.

Current is reduced for the duration of the RESET# pulse. When RESET# is held at  $V_{SS} \pm 0.3$  V, the device draws CMOS standby current ( $I_{CC4}$ ). If RESET# is held at  $V_{IL}$  but not within  $V_{SS} \pm 0.3$  V, the standby current will be greater.

The RESET# pin may be tied to the system reset circuitry. A system reset would thus also reset the Flash memory, enabling the system to read the boot-up firmware from the Flash memory.

Refer to the [AC Characteristics](#) tables for RESET# parameters and to Figure 16 for the timing diagram.

### Output Disable Mode

When the OE# input is at  $V_{IH}$ , output from the device is disabled. The output pins are placed in the high impedance state.

Sector	A21-A15							Sector Size (Kbytes/Kwords)	8-bit Address Range (in hexadecimal)	16-bit Address Range (in hexadecimal)
SA0	0	0	0	0	0	0	0	64/32	000000-00FFFF	000000-007FFF
SA1	0	0	0	0	0	0	1	64/32	010000-01FFFF	008000-00FFFF
SA2	0	0	0	0	0	1	0	64/32	020000-02FFFF	010000-017FFF
SA3	0	0	0	0	0	1	1	64/32	030000-03FFFF	018000-01FFFF
SA4	0	0	0	0	1	0	0	64/32	040000-04FFFF	020000-027FFF
SA5	0	0	0	0	1	0	1	64/32	050000-05FFFF	028000-02FFFF
SA6	0	0	0	0	1	1	0	64/32	060000-06FFFF	030000-037FFF
SA7	0	0	0	0	1	1	1	64/32	070000-07FFFF	038000-03FFFF
SA8	0	0	0	1	0	0	0	64/32	080000-08FFFF	040000-047FFF
SA9	0	0	0	1	0	0	1	64/32	090000-09FFFF	048000-04FFFF
SA10	0	0	0	1	0	1	0	64/32	0A0000-0AFFFF	050000-057FFF
SA11	0	0	0	1	0	1	1	64/32	0B0000-0BFFFF	058000-05FFFF
SA12	0	0	0	1	1	0	0	64/32	0C0000-0CFFFF	060000-067FFF
SA13	0	0	0	1	1	0	1	64/32	0D0000-0DFFFF	068000-06FFFF
SA14	0	0	0	1	1	1	0	64/32	0E0000-0EFFFF	070000-077FFF
SA15	0	0	0	1	1	1	1	64/32	0F0000-0FFFFF	078000-07FFFF
SA16	0	0	1	0	0	0	0	64/32	100000-10FFFF	080000-087FFF
SA17	0	0	1	0	0	0	1	64/32	110000-11FFFF	088000-08FFFF
SA18	0	0	1	0	0	1	0	64/32	120000-12FFFF	090000-097FFF
SA19	0	0	1	0	0	1	1	64/32	130000-13FFFF	098000-09FFFF
SA20	0	0	1	0	1	0	0	64/32	140000-14FFFF	0A0000-0A7FFF
SA21	0	0	1	0	1	0	1	64/32	150000-15FFFF	0A8000-0AFFFF
SA22	0	0	1	0	1	1	0	64/32	160000-16FFFF	0B0000-0B7FFF
SA23	0	0	1	0	1	1	1	64/32	170000-17FFFF	0B8000-0BFFFF
SA24	0	0	1	1	0	0	0	64/32	180000-18FFFF	0C0000-0C7FFF
SA25	0	0	1	1	0	0	1	64/32	190000-19FFFF	0C8000-0CFFFF
SA26	0	0	1	1	0	1	0	64/32	1A0000-1AFFFF	0D0000-0D7FFF
SA27	0	0	1	1	0	1	1	64/32	1B0000-1BFFFF	0D8000-0DFFFF
SA28	0	0	1	1	1	0	0	64/32	1C0000-1CFFFF	0E0000-0E7FFF
SA29	0	0	1	1	1	0	1	64/32	1D0000-1DFFFF	0E8000-0EFFFF
SA30	0	0	1	1	1	1	0	64/32	1E0000-1EFFFF	0F0000-0F7FFF
SA31	0	0	1	1	1	1	1	64/32	1F0000-1FFFFF	0F8000-0FFFFF
SA32	0	1	0	0	0	0	0	64/32	200000-20FFFF	100000-107FFF
SA33	0	1	0	0	0	0	1	64/32	210000-21FFFF	108000-10FFFF
SA34	0	1	0	0	0	1	0	64/32	220000-22FFFF	110000-117FFF
SA35	0	1	0	0	0	1	1	64/32	230000-23FFFF	118000-11FFFF
SA36	0	1	0	0	1	0	0	64/32	240000-24FFFF	120000-127FFF
SA37	0	1	0	0	1	0	1	64/32	250000-25FFFF	128000-12FFFF
SA38	0	1	0	0	1	1	0	64/32	260000-26FFFF	130000-137FFF
SA39	0	1	0	0	1	1	1	64/32	270000-27FFFF	138000-13FFFF
SA40	0	1	0	1	0	0	0	64/32	280000-28FFFF	140000-147FFF
SA41	0	1	0	1	0	0	1	64/32	290000-29FFFF	148000-14FFFF
SA42	0	1	0	1	0	1	0	64/32	2A0000-2AFFFF	150000-157FFF
SA43	0	1	0	1	0	1	1	64/32	2B0000-2BFFFF	158000-15FFFF
SA44	0	1	0	1	1	0	0	64/32	2C0000-2CFFFF	160000-167FFF
SA45	0	1	0	1	1	0	1	64/32	2D0000-2DFFFF	168000-16FFFF
SA46	0	1	0	1	1	1	0	64/32	2E0000-2EFFFF	170000-177FFF
SA47	0	1	0	1	1	1	1	64/32	2F0000-2FFFFF	178000-17FFFF
SA48	0	1	1	0	0	0	0	64/32	300000-30FFFF	180000-187FFF
SA49	0	1	1	0	0	0	1	64/32	310000-31FFFF	188000-18FFFF
SA50	0	1	1	0	0	1	0	64/32	320000-32FFFF	190000-197FFF
SA51	0	1	1	0	0	1	1	64/32	330000-33FFFF	198000-19FFFF
SA52	0	1	1	0	1	0	0	64/32	340000-34FFFF	1A0000-1A7FFF
SA53	0	1	1	0	1	0	1	64/32	350000-35FFFF	1A8000-1AFFFF
SA54	0	1	1	0	1	1	0	64/32	360000-36FFFF	1B0000-1B7FFF
SA55	0	1	1	0	1	1	1	64/32	370000-37FFFF	1B8000-1BFFFF

Sector	A21-A15							Sector Size (Kbytes/Kwords)	8-bit Address Range (in hexadecimal)	16-bit Address Range (in hexadecimal)
	0	1	1	1	0	0	0			
SA56	0	1	1	1	0	0	0	64/32	380000-38FFFF	1C0000-1C7FFF
SA57	0	1	1	1	0	0	1	64/32	390000-39FFFF	1C8000-1CFFFF
SA58	0	1	1	1	0	1	0	64/32	3A0000-3AFFFF	1D0000-1D7FFF
SA59	0	1	1	1	0	1	1	64/32	3B0000-3BFFFF	1D8000-1DFFFF
SA60	0	1	1	1	1	0	0	64/32	3C0000-3CFFFF	1E0000-1E7FFF
SA61	0	1	1	1	1	0	1	64/32	3D0000-3DFFFF	1E8000-1EFFFF
SA62	0	1	1	1	1	1	0	64/32	3E0000-3EFFFF	1F0000-1F7FFF
SA63	0	1	1	1	1	1	1	64/32	3F0000-3FFFFF	1F8000-1FFFFF
SA64	1	0	0	0	0	0	0	64/32	400000-40FFFF	200000-207FFF
SA65	1	0	0	0	0	0	1	64/32	410000-41FFFF	208000-20FFFF
SA66	1	0	0	0	0	1	0	64/32	420000-42FFFF	210000-217FFF
SA67	1	0	0	0	0	1	1	64/32	430000-43FFFF	218000-21FFFF
SA68	1	0	0	0	1	0	0	64/32	440000-44FFFF	220000-227FFF
SA69	1	0	0	0	1	0	1	64/32	450000-45FFFF	228000-22FFFF
SA70	1	0	0	0	1	1	0	64/32	460000-46FFFF	230000-237FFF
SA71	1	0	0	0	1	1	1	64/32	470000-47FFFF	238000-23FFFF
SA72	1	0	0	1	0	0	0	64/32	480000-48FFFF	240000-247FFF
SA73	1	0	0	1	0	0	1	64/32	490000-49FFFF	248000-24FFFF
SA74	1	0	0	1	0	1	0	64/32	4A0000-4AFFFF	250000-257FFF
SA75	1	0	0	1	0	1	1	64/32	4B0000-4BFFFF	258000-25FFFF
SA76	1	0	0	1	1	0	0	64/32	4C0000-4CFFFF	260000-267FFF
SA77	1	0	0	1	1	0	1	64/32	4D0000-4DFFFF	268000-26FFFF
SA78	1	0	0	1	1	1	0	64/32	4E0000-4EFFFF	270000-277FFF
SA79	1	0	0	1	1	1	1	64/32	4F0000-4FFFFF	278000-27FFFF
SA80	1	0	1	0	0	0	0	64/32	500000-50FFFF	280000-287FFF
SA81	1	0	1	0	0	0	1	64/32	510000-51FFFF	288000-28FFFF
SA82	1	0	1	0	0	1	0	64/32	520000-52FFFF	290000-297FFF
SA83	1	0	1	0	0	1	1	64/32	530000-53FFFF	298000-29FFFF
SA84	1	0	1	0	1	0	0	64/32	540000-54FFFF	2A0000-2A7FFF
SA85	1	0	1	0	1	0	1	64/32	550000-55FFFF	2A8000-2AFFFF
SA86	1	0	1	0	1	1	0	64/32	560000-56FFFF	2B0000-2B7FFF
SA87	1	0	1	0	1	1	1	64/32	570000-57FFFF	2B8000-2BFFFF
SA88	1	0	1	1	0	0	0	64/32	580000-58FFFF	2C0000-2C7FFF
SA89	1	0	1	1	0	0	1	64/32	590000-59FFFF	2C8000-2CFFFF
SA90	1	0	1	1	0	1	0	64/32	5A0000-5AFFFF	2D0000-2D7FFF
SA91	1	0	1	1	0	1	1	64/32	5B0000-5BFFFF	2D8000-2DFFFF
SA92	1	0	1	1	1	0	0	64/32	5C0000-5CFFFF	2E0000-2E7FFF
SA93	1	0	1	1	1	0	1	64/32	5D0000-5DFFFF	2E8000-2EFFFF
SA94	1	0	1	1	1	1	0	64/32	5E0000-5EFFFF	2F0000-2F7FFF
SA95	1	0	1	1	1	1	1	64/32	5F0000-5FFFFF	2F8000-2FFFFF
SA96	1	1	0	0	0	0	0	64/32	600000-60FFFF	300000-307FFF
SA97	1	1	0	0	0	0	1	64/32	610000-61FFFF	308000-30FFFF
SA98	1	1	0	0	0	1	0	64/32	620000-62FFFF	310000-317FFF
SA99	1	1	0	0	0	1	1	64/32	630000-63FFFF	318000-31FFFF
SA100	1	1	0	0	1	0	0	64/32	640000-64FFFF	320000-327FFF
SA101	1	1	0	0	1	0	1	64/32	650000-65FFFF	328000-32FFFF
SA102	1	1	0	0	1	1	0	64/32	660000-66FFFF	330000-337FFF
SA103	1	1	0	0	1	1	1	64/32	670000-67FFFF	338000-33FFFF
SA104	1	1	0	1	0	0	0	64/32	680000-68FFFF	340000-347FFF
SA105	1	1	0	1	0	0	1	64/32	690000-69FFFF	348000-34FFFF
SA106	1	1	0	1	0	1	0	64/32	6A0000-6AFFFF	350000-357FFF
SA107	1	1	0	1	0	1	1	64/32	6B0000-6BFFFF	358000-35FFFF
SA108	1	1	0	1	1	0	0	64/32	6C0000-6CFFFF	360000-367FFF
SA109	1	1	0	1	1	0	1	64/32	6D0000-6DFFFF	368000-36FFFF
SA110	1	1	0	1	1	1	0	64/32	6E0000-6EFFFF	370000-377FFF
SA111	1	1	0	1	1	1	1	64/32	6F0000-6FFFFF	378000-37FFFF



Sector	A21-A15							Sector Size (Kbytes/Kwords)	8-bit Address Range (in hexadecimal)	16-bit Address Range (in hexadecimal)
	1	1	1	0	0	0	0			
SA112	1	1	1	0	0	0	0	64/32	700000-70FFFF	380000-387FFF
SA113	1	1	1	0	0	0	1	64/32	710000-71FFFF	388000-38FFFF
SA114	1	1	1	0	0	1	0	64/32	720000-72FFFF	390000-397FFF
SA115	1	1	1	0	0	1	1	64/32	730000-73FFFF	398000-39FFFF
SA116	1	1	1	0	1	0	0	64/32	740000-74FFFF	3A0000-3A7FFF
SA117	1	1	1	0	1	0	1	64/32	750000-75FFFF	3A8000-3AFFFF
SA118	1	1	1	0	1	1	0	64/32	760000-76FFFF	3B0000-3B7FFF
SA119	1	1	1	0	1	1	1	64/32	770000-77FFFF	3B8000-3BFFFF
SA120	1	1	1	1	0	0	0	64/32	780000-78FFFF	3C0000-3C7FFF
SA121	1	1	1	1	0	0	1	64/32	790000-79FFFF	3C8000-3CFFFF
SA122	1	1	1	1	0	1	0	64/32	7A0000-7AFFFF	3D0000-3D7FFF
SA123	1	1	1	1	0	1	1	64/32	7B0000-7BFFFF	3D8000-3DFFFF
SA124	1	1	1	1	1	0	0	64/32	7C0000-7CFFFF	3E0000-3E7FFF
SA125	1	1	1	1	1	0	1	64/32	7D0000-7DFFFF	3E8000-3EFFFF
SA126	1	1	1	1	1	1	0	64/32	7E0000-7EFFFF	3F0000-3F7FFF
SA127	1	1	1	1	1	1	1	64/32	7F0000-7FFFFF	3F8000-3FFFFF

**Note:** The address range is A21:A-1 in byte mode (BYTE# =  $V_{IL}$ ) or A21:A0 in word mode (BYTE# =  $V_{IH}$ ).

### Autoselect Mode

The autoselect mode provides manufacturer and device identification, and sector protection verification, through identifier codes output on DQ7–DQ0. This mode is primarily intended for programming equipment to automatically match a device to be programmed with its corresponding programming algorithm. However, the autoselect codes can also be accessed in-system through the command register.

When using programming equipment, the autoselect mode requires  $V_{ID}$  on address pin A9. Address pins A6, A3, A2, A1, and A0 must be as shown in Table 3.

In addition, when verifying sector protection, the sector address must appear on the appropriate highest order address bits (see Table 2). Table 3 shows the remaining address bits that are don't care. When all necessary bits have been set as required, the programming equipment may then read the corresponding identifier code on DQ7–DQ0.

To access the autoselect codes in-system, the host system can issue the autoselect command via the command register, as shown in Tables 10 and 11. This method does not require  $V_{ID}$ . Refer to the Autoselect Command Sequence section for more information.

**Table 2. Autoselect Codes, (High Voltage Method)**

Description	CE#	OE#	WE#	A21 to A15	A14 to A10	A9	A8 to A7	A6	A5 to A4	A3 to A2	A1	A0	DQ8 to DQ15		DQ7 to DQ0	
													BYTE#= $V_{IH}$	BYTE#= $V_{IL}$		
Manufacturer ID: AMD	L	L	H	X	X	$V_{ID}$	X	L	X	L	L	L	00	X	01h	
Device ID	Cycle 1		L	L	H	X	X	$V_{ID}$	X	L	L	L	H	22	X	7Eh
	Cycle 2										H	H	L	22	X	0Ch
	Cycle 3										H	H	H	22	X	01h
Sector Protection Verification	L	L	H	SA	X	$V_{ID}$	X	L	X	L	H	L	X	X	01h (protected), 00h (unprotected)	
SecSi Sector Indicator Bit (DQ7), WP# protects highest address sector	L	L	H	X	X	$V_{ID}$	X	L	X	L	H	H	X	X	98h (factory locked), 18h (not factory locked)	
SecSi Sector Indicator Bit (DQ7), WP# protects lowest address sector	L	L	H	X	X	$V_{ID}$	X	L	X	L	H	H	X	X	88h (factory locked), 08h (not factory locked)	

**Legend:** L = Logic Low =  $V_{IL}$ , H = Logic High =  $V_{IH}$ , SA = Sector Address, X = Don't care.

### Sector Group Protection and Unprotection

The hardware sector group protection feature disables both program and erase operations in any sector group. In this device, a sector group consists of four adjacent sectors that are protected or unprotected at the same time (see Table 4). The hardware sector group unprotection feature re-enables both program and erase operations in previously protected sector groups. Sector group protection/unprotection can be implemented via two methods.

Sector protection/unprotection requires  $V_{ID}$  on the RESET# pin only, and can be implemented either in-system or via programming equipment. Figure 2 shows

the algorithms and Figure 24 shows the timing diagram. This method uses standard microprocessor bus cycle timing. For sector group unprotect, all unprotected sector groups must first be protected prior to the first sector group unprotect write cycle.

The device is shipped with all sector groups unprotected. AMD offers the option of programming and protecting sector groups at its factory prior to shipping the device through AMD's ExpressFlash™ Service. Contact an AMD representative for details.

It is possible to determine whether a sector group is protected or unprotected. See the Autoselect Mode section for details.

**Table 3. Sector Group Protection/Unprotection Address Table**

Sector Group	A21–A15
SA0	0000000
SA1	0000001
SA2	0000010
SA3	0000011
SA4–SA7	00001xx
SA8–SA11	00010xx
SA12–SA15	00011xx

**Table 3. Sector Group Protection/Unprotection Address Table**

Sector Group	A21–A15
SA16–SA19	00100xx
SA20–SA23	00101xx
SA24–SA27	00110xx
SA28–SA31	00111xx
SA32–SA35	01000xx
SA36–SA39	01001xx
SA40–SA43	01010xx
SA44–SA47	01011xx
SA48–SA51	01100xx
SA52–SA55	01101xx
SA56–SA59	01110xx
SA60–SA63	01111xx
SA64–SA67	10000xx
SA68–SA71	10001xx
SA72–SA75	10010xx
SA76–SA79	10011xx
SA80–SA83	10100xx
SA84–SA87	10101xx
SA88–SA91	10110xx
SA92–SA95	10111xx
SA96–SA99	11000xx
SA100–SA103	11001xx
SA104–SA107	11010xx
SA108–SA111	11011xx
SA112–SA115	11100xx
SA116–SA119	11101xx
SA120–SA123	11110xx
SA124	1111100
SA125	1111101
SA126	1111110
SA127	1111111

## Write Protect (WP#)

The Write Protect function provides a hardware method of protecting the first or last sector without using  $V_{ID}$ . Write Protect is one of two functions provided by the WP#/ACC input.

If the system asserts  $V_{IL}$  on the WP#/ACC pin, the device disables program and erase functions in the first or last sector independently of whether those sectors were protected or unprotected using the method described in “Sector Group Protection and Unprotection”. Note that if WP#/ACC is at  $V_{IL}$  when the device is in the standby mode, the maximum input load current is increased. See the table in “DC Characteristics”.

If the system asserts  $V_{IH}$  on the WP#/ACC pin, the device reverts to whether the first or last sector was previously set to be protected or unprotected using the method described in “Sector Group Protection and

Unprotection”. Note: No external pullup is necessary since the WP#/ACC pin has internal pullup to  $V_{CC}$ .

## Temporary Sector Group Unprotect

(Note: In this device, a sector group consists of four adjacent sectors that are protected or unprotected at the same time (see Table 4).

This feature allows temporary unprotection of previously protected sector groups to change data in-system. The Sector Group Unprotect mode is activated by setting the RESET# pin to  $V_{ID}$ . During this mode, formerly protected sector groups can be programmed or erased by selecting the sector group addresses. Once  $V_{ID}$  is removed from the RESET# pin, all the previously protected sector groups are protected again. Figure 1 shows the algorithm, and Figure 23 shows the timing diagrams, for this feature.

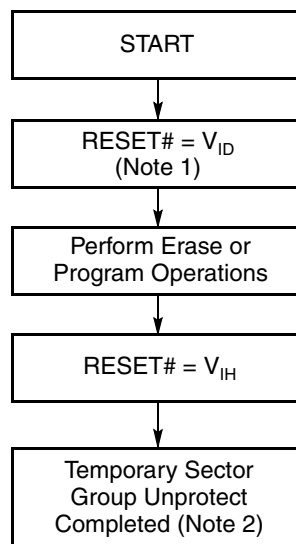

### Notes:

1. All protected sector groups unprotected (If WP# =  $V_{IL}$ , the first or last sector will remain protected).
2. All previously protected sector groups are protected once again.

Figure 1. Temporary Sector Group Unprotect Operation

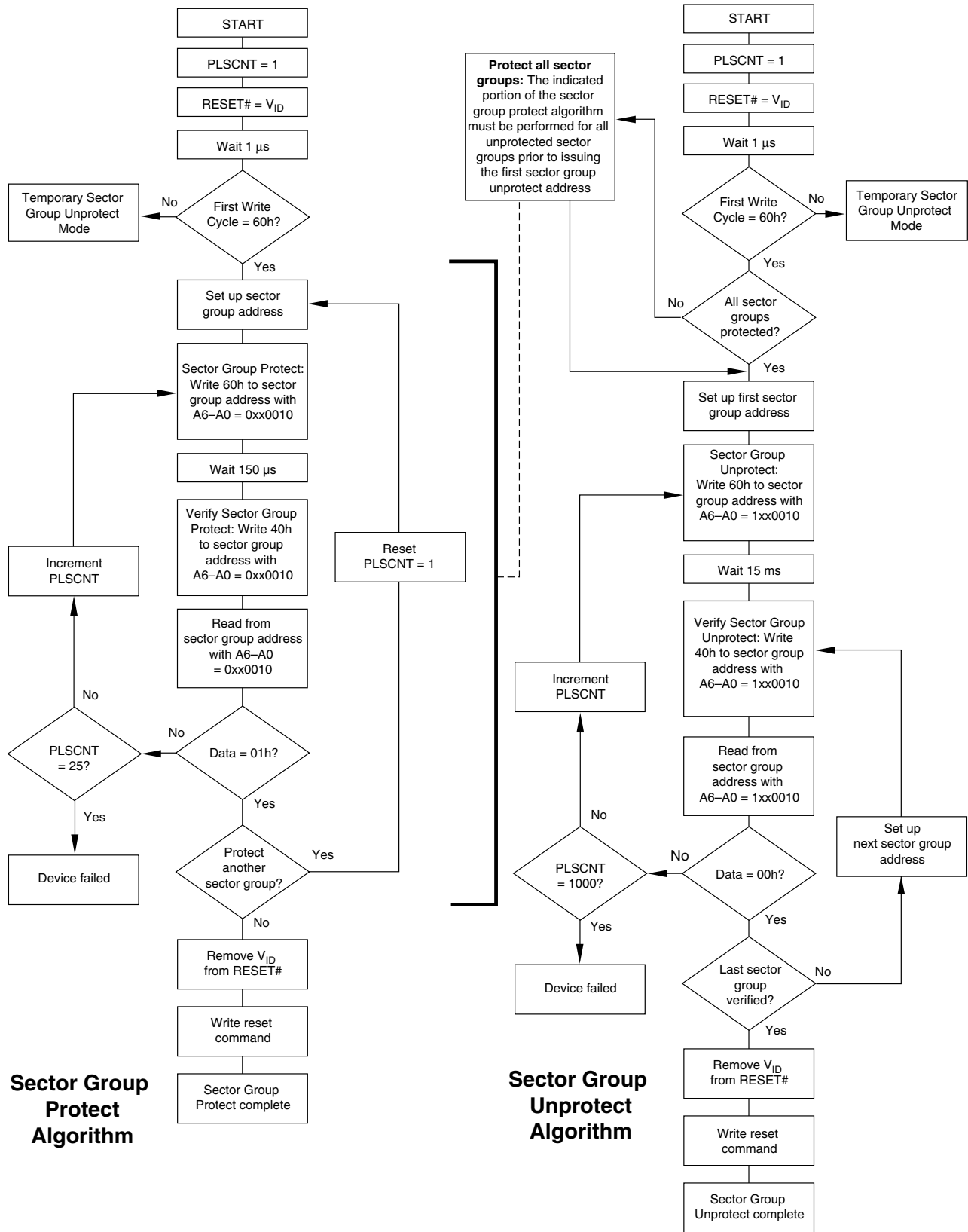

Figure 2. In-System Sector Group Protect/Unprotect Algorithms

## SecSi (Secured Silicon) Sector Flash Memory Region

The SecSi (Secured Silicon) Sector feature provides a Flash memory region that enables permanent part identification through an Electronic Serial Number (ESN). The SecSi Sector is 128 words/256 bytes in length, and uses a SecSi Sector Indicator Bit (DQ7) to indicate whether or not the SecSi Sector is locked when shipped from the factory. This bit is permanently set at the factory and cannot be changed, which prevents cloning of a factory locked part. This ensures the security of the ESN once the product is shipped to the field.

AMD offers the device with the SecSi Sector either factory locked or customer lockable. The factory-locked version is always protected when shipped from the factory, and has the SecSi (Secured Silicon) Sector Indicator Bit permanently set to a “1.” The customer-lockable version is shipped with the SecSi Sector unprotected, allowing customers to program the sector after receiving the device. The customer-lockable version also has the SecSi Sector Indicator Bit permanently set to a “0.” Thus, the SecSi Sector Indicator Bit prevents customer-lockable devices from being used to replace devices that are factory locked.

The SecSi sector address space in this device is allocated as follows:

SecSi Sector Address Range		Standard Factory Locked	ExpressFlash Factory Locked	Customer Lockable
x16	x8			
000000h–000007h	000000h–00000Fh	ESN	ESN or determined by customer	Determined by customer
000008h–00007Fh	000010h–0000FFh	Unavailable	Determined by customer	

The system accesses the SecSi Sector through a command sequence (see “Enter SecSi Sector/Exit SecSi Sector Command Sequence”). After the system has written the Enter SecSi Sector command sequence, it may read the SecSi Sector by using the addresses normally occupied by the first sector (SA0). This mode of operation continues until the system issues the Exit SecSi Sector command sequence, or until power is removed from the device. On power-up, or following a hardware reset, the device reverts to sending commands to sector SA0.

### Factory Locked: SecSi Sector Programmed and Protected At the Factory

In devices with an ESN, the SecSi Sector is protected when the device is shipped from the factory. The SecSi Sector cannot be modified in any way. See [Table 5](#) for SecSi Sector addressing.

Customers may opt to have their code programmed by AMD through the AMD ExpressFlash service. The devices are then shipped from AMD’s factory with the SecSi Sector permanently locked. Contact an AMD representative for details on using AMD’s ExpressFlash service.

### Customer Lockable: SecSi Sector NOT Programmed or Protected At the Factory

As an alternative to the factory-locked version, the device may be ordered such that the customer may pro-

gram and protect the 128-word/256 bytes SecSi sector. See [Table 5](#) for SecSi Sector addressing.

The system may program the SecSi Sector using the write-buffer, accelerated and/or unlock bypass methods, in addition to the standard programming command sequence. See [Command Definitions](#).

Programming and protecting the SecSi Sector must be used with caution since, once protected, there is no procedure available for unprotecting the SecSi Sector area and none of the bits in the SecSi Sector memory space can be modified in any way.

The SecSi Sector area can be protected using one of the following procedures:

- Write the three-cycle Enter SecSi Sector Region command sequence, and then follow the in-system sector protect algorithm as shown in [Figure 2](#), except that *RESET#* may be at either  $V_{IH}$  or  $V_{ID}$ . This allows in-system protection of the SecSi Sector without raising any device pin to a high voltage. Note that this method is only applicable to the SecSi Sector.
- To verify the protect/unprotect status of the SecSi Sector, follow the algorithm shown in [Figure 3](#).

Once the SecSi Sector is programmed, locked and verified, the system must write the Exit SecSi Sector Region command sequence to return to reading and writing within the remainder of the array.

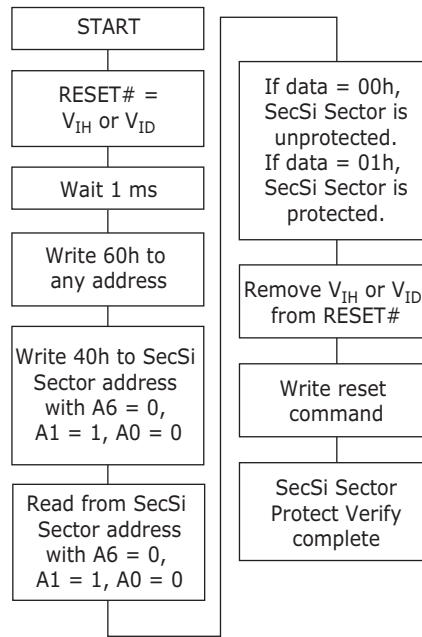

Figure 3. SecSi Sector Protect Verify

### Hardware Data Protection

The command sequence requirement of unlock cycles for programming or erasing provides data protection against inadvertent writes (refer to Tables 10 and 11 for command definitions). In addition, the following hardware data protection measures prevent accidental erasure or programming, which might otherwise be caused by spurious system level signals during  $V_{CC}$  power-up and power-down transitions, or from system noise.

#### Low $V_{CC}$ Write Inhibit

When  $V_{CC}$  is less than  $V_{LKO}$ , the device does not accept any write cycles. This protects data during  $V_{CC}$  power-up and power-down. The command register and all internal program/erase circuits are disabled, and the device resets to the read mode. Subsequent writes are ignored until  $V_{CC}$  is greater than  $V_{LKO}$ . The system must provide the proper signals to the control

### COMMON FLASH MEMORY INTERFACE (CFI)

The Common Flash Interface (CFI) specification outlines device and host system software interrogation handshake, which allows specific vendor-specified software algorithms to be used for entire families of devices. Software support can then be device-independent, JEDEC ID-independent, and forward- and backward-compatible for the specified flash device families. Flash vendors can standardize their existing interfaces for long-term compatibility.

This device enters the CFI Query mode when the system writes the CFI Query command, 98h, to address

pins to prevent unintentional writes when  $V_{CC}$  is greater than  $V_{LKO}$ .

#### Write Pulse “Glitch” Protection

Noise pulses of less than 5 ns (typical) on OE#, CE# or WE# do not initiate a write cycle.

#### Logical Inhibit

Write cycles are inhibited by holding any one of OE# =  $V_{IL}$ , CE# =  $V_{IH}$  or WE# =  $V_{IH}$ . To initiate a write cycle, CE# and WE# must be a logical zero while OE# is a logical one.

#### Power-Up Write Inhibit

If WE# = CE# =  $V_{IL}$  and OE# =  $V_{IH}$  during power up, the device does not accept commands on the rising edge of WE#. The internal state machine is automatically reset to the read mode on power-up.

55h, any time the device is ready to read array data. The system can read CFI information at the addresses given in Tables 6–9. To terminate reading CFI data, the system must write the reset command.

The system can also write the CFI query command when the device is in the autoselect mode. The device enters the CFI query mode, and the system can read CFI data at the addresses given in Tables 6–9. The system must write the reset command to return the device to reading array data.

For further information, please refer to the CFI Specification and CFI Publication 100, available via the World Wide Web at <http://www.amd.com/flash/cfi>. Alternately,

contact a sales office or representative for copies of these documents.

**Table 4. CFI Query Identification String**

Addresses (x16)	Addresses (x8)	Data	Description
10h 11h 12h	20h 22h 24h	0051h 0052h 0059h	Query Unique ASCII string "QRY"
13h 14h	26h 28h	0002h 0000h	Primary OEM Command Set
15h 16h	2Ah 2Ch	0040h 0000h	Address for Primary Extended Table
17h 18h	2Eh 30h	0000h 0000h	Alternate OEM Command Set (00h = none exists)
19h 1Ah	32h 34h	0000h 0000h	Address for Alternate OEM Extended Table (00h = none exists)

**Table 5. System Interface String**

Addresses (x16)	Addresses (x8)	Data	Description
1Bh	36h	0027h	$V_{CC}$ Min. (write/erase) D7–D4: volt, D3–D0: 100 millivolt
1Ch	38h	0036h	$V_{CC}$ Max. (write/erase) D7–D4: volt, D3–D0: 100 millivolt
1Dh	3Ah	0000h	$V_{PP}$ Min. voltage (00h = no $V_{PP}$ pin present)
1Eh	3Ch	0000h	$V_{PP}$ Max. voltage (00h = no $V_{PP}$ pin present)
1Fh	3Eh	0007h	Typical timeout per single byte/word write $2^N$ $\mu$ s
20h	40h	0007h	Typical timeout for Min. size buffer write $2^N$ $\mu$ s (00h = not supported)
21h	42h	000Ah	Typical timeout per individual block erase $2^N$ ms
22h	44h	0000h	Typical timeout for full chip erase $2^N$ ms (00h = not supported)
23h	46h	0001h	Max. timeout for byte/word write $2^N$ times typical
24h	48h	0005h	Max. timeout for buffer write $2^N$ times typical
25h	4Ah	0004h	Max. timeout per individual block erase $2^N$ times typical
26h	4Ch	0000h	Max. timeout for full chip erase $2^N$ times typical (00h = not supported)



Table 6. Device Geometry Definition

Addresses (x16)	Addresses (x8)	Data	Description
27h	4Eh	0017h	Device Size = 2 <sup>N</sup> byte
28h 29h	50h 52h	0002h 0000h	Flash Device Interface description (refer to CFI publication 100)
2Ah 2Bh	54h 56h	0005h 0000h	Max. number of byte in multi-byte write = 2 <sup>N</sup> (00h = not supported)
2Ch	58h	0001h	Number of Erase Block Regions within device (01h = uniform device, 02h = boot device)
2Dh 2Eh 2Fh 30h	5Ah 5Ch 5Eh 60h	007Fh 0000h 0000h 0001h	Erase Block Region 1 Information (refer to the CFI specification or CFI publication 100)
31h 32h 33h 34h	62h 64h 66h 68h	0000h 0000h 0000h 0000h	Erase Block Region 2 Information (refer to CFI publication 100)
35h 36h 37h 38h	6Ah 6Ch 6Eh 70h	0000h 0000h 0000h 0000h	Erase Block Region 3 Information (refer to CFI publication 100)
39h 3Ah 3Bh 3Ch	72h 74h 76h 78h	0000h 0000h 0000h 0000h	Erase Block Region 4 Information (refer to CFI publication 100)

Table 7. Primary Vendor-Specific Extended Query

Addresses (x16)	Addresses (x8)	Data	Description
40h 41h 42h	80h 82h 84h	0050h 0052h 0049h	Query-unique ASCII string "PRI"
43h	86h	0031h	Major version number, ASCII
44h	88h	0033h	Minor version number, ASCII
45h	8Ah	0008h	Address Sensitive Unlock (Bits 1-0) 0 = Required, 1 = Not Required Process Technology (Bits 7-2) 0010b = 0.23 $\mu$ m MirrorBit
46h	8Ch	0002h	Erase Suspend 0 = Not Supported, 1 = To Read Only, 2 = To Read & Write
47h	8Eh	0001h	Sector Protect 0 = Not Supported, X = Number of sectors in per group
48h	90h	0001h	Sector Temporary Unprotect 00 = Not Supported, 01 = Supported
49h	92h	0004h	Sector Protect/Unprotect scheme 04 = 29LV800 mode
4Ah	94h	0000h	Simultaneous Operation 00 = Not Supported, X = Number of Sectors in Bank
4Bh	96h	0000h	Burst Mode Type 00 = Not Supported, 01 = Supported
4Ch	98h	0001h	Page Mode Type 00 = Not Supported, 01 = 4 Word/8 Byte Page, 02 = 8 Word/16 Byte Page
4Dh	9Ah	00B5h	ACC (Acceleration) Supply Minimum 00h = Not Supported, D7-D4: Volt, D3-D0: 100 mV
4Eh	9Ch	00C5h	ACC (Acceleration) Supply Maximum 00h = Not Supported, D7-D4: Volt, D3-D0: 100 mV
4Fh	9Eh	0004h/ 0005h	Top/Bottom Boot Sector Flag 00h = Uniform Device without WP# protect, 02h = Bottom Boot Device, 03h = Top Boot Device, 04h = Uniform sectors bottom WP# protect, 05h = Uniform sectors top WP# protect
50h	A0h	0001h	Program Suspend 00h = Not Supported, 01h = Supported

## COMMAND DEFINITIONS

Writing specific address and data commands or sequences into the command register initiates device operations. Tables 10 and 11 define the valid register command sequences. Writing **incorrect address and data values** or writing them in the **improper sequence** may place the device in an unknown state. A reset command is then required to return the device to reading array data.

All addresses are latched on the falling edge of WE# or CE#, whichever happens later. All data is latched on the rising edge of WE# or CE#, whichever happens first. Refer to the [AC Characteristics](#) section for timing diagrams.

### Reading Array Data

The device is automatically set to reading array data after device power-up. No commands are required to retrieve data. The device is ready to read array data

after completing an Embedded Program or Embedded Erase algorithm.

After the device accepts an Erase Suspend command, the device enters the erase-suspend-read mode, after which the system can read data from any non-erase-suspended sector. After completing a programming operation in the Erase Suspend mode, the system may once again read array data with the same exception. See the [Erase Suspend/Erase Resume Commands](#) section for more information.

The system *must* issue the reset command to return the device to the read (or erase-suspend-read) mode if DQ5 goes high during an active program or erase operation, or if the device is in the autoselect mode. See the next section, [Reset Command](#), for more information.

See also [Requirements for Reading Array Data](#) in the [Device Bus Operations](#) section for more information.

The [Read-Only Operations](#) table provides the read parameters, and Figure 14 shows the timing diagram.

### Reset Command

Writing the reset command resets the device to the read or erase-suspend-read mode. Address bits are don't cares for this command.

The reset command may be written between the sequence cycles in an erase command sequence before erasing begins. This resets the device to the read mode. Once erasure begins, however, the device ignores reset commands until the operation is complete.

The reset command may be written between the sequence cycles in a program command sequence before programming begins. This resets the device to the read mode. If the program command sequence is written while the device is in the Erase Suspend mode, writing the reset command returns the device to the erase-suspend-read mode. Once programming begins, however, the device ignores reset commands until the operation is complete.

The reset command may be written between the sequence cycles in an autoselect command sequence. Once in the autoselect mode, the reset command must be written to return to the read mode. If the device entered the autoselect mode while in the Erase Suspend mode, writing the reset command returns the device to the erase-suspend-read mode.

If DQ5 goes high during a program or erase operation, writing the reset command returns the device to the read mode (or erase-suspend-read mode if the device was in Erase Suspend).

Note that if DQ1 goes high during a Write Buffer Programming operation, the system must write the Write-to-Buffer-Abort Reset command sequence to reset the device for the next operation.

### Autoselect Command Sequence

The autoselect command sequence allows the host system to read several identifier codes at specific addresses:

Identifier Code	A7:A0 (x16)	A6:A-1 (x8)
Manufacturer ID	00h	00h
Device ID, Cycle 1	01h	02h
Device ID, Cycle 2	0Eh	1Ch
Device ID, Cycle 3	0Fh	1Eh
SecSi Sector Factory Protect	03h	06h
Sector Protect Verify	(SA)02h	(SA)04h

**Note:** The device ID is read over three cycles. SA = Sector Address

Tables 10 and 11 show the address requirements and codes. This method is an alternative to that shown in Table 3, which is intended for PROM programmers and requires V<sub>ID</sub> on address pin A9. The autoselect command sequence may be written to an address that is either in the read or erase-suspend-read mode. The autoselect command may not be written while the device is actively programming or erasing.

The autoselect command sequence is initiated by first writing two unlock cycles. This is followed by a third write cycle that contains the autoselect command. The device then enters the autoselect mode. The system may read at any address any number of times without initiating another autoselect command sequence:

The system must write the reset command to return to the read mode (or erase-suspend-read mode if the device was previously in Erase Suspend).

### Enter SecSi Sector/Exit SecSi Sector Command Sequence

The SecSi Sector region provides a secured data area containing an 8-word/16-byte random Electronic Serial Number (ESN). The system can access the SecSi Sector region by issuing the three-cycle Enter SecSi

Sector command sequence. The device continues to access the SecSi Sector region until the system issues the four-cycle Exit SecSi Sector command sequence. The Exit SecSi Sector command sequence returns the device to normal operation. Tables 10 and 11 show the address and data requirements for both command sequences. See also “SecSi (Secured Silicon) Sector Flash Memory Region” for further information. *Note that the ACC function and unlock bypass modes are not available when the SecSi Sector is enabled.*

### Word/Byte Program Command Sequence

Programming is a four-bus-cycle operation. The program command sequence is initiated by writing two unlock write cycles, followed by the program set-up command. The program address and data are written next, which in turn initiate the Embedded Program algorithm. The system is *not* required to provide further controls or timings. The device automatically provides internally generated program pulses and verifies the programmed cell margin. Tables 10 and 11 show the address and data requirements for the word/byte program command sequence, respectively.

When the Embedded Program algorithm is complete, the device then returns to the read mode and addresses are no longer latched. The system can determine the status of the program operation by using DQ7 or DQ6. Refer to the [Write Operation Status](#) section for information on these status bits.

Any commands written to the device during the Embedded Program Algorithm are ignored. Note that a **hardware reset** immediately terminates the program operation. The program command sequence should be reinitiated once the device has returned to the read mode, to ensure data integrity. *Note that the ACC function and unlock bypass modes are not available when the SecSi Sector is enabled.*

Programming is allowed in any sequence and across sector boundaries. **A bit cannot be programmed from “0” back to a “1.”** Attempting to do so may cause the device to set DQ5 = 1, or cause the DQ7 and DQ6 status bits to indicate the operation was successful. However, a succeeding read will show that the data is still “0.” Only erase operations can convert a “0” to a “1.”

### Unlock Bypass Command Sequence

The unlock bypass feature allows the system to program words to the device faster than using the standard program command sequence. The unlock bypass command sequence is initiated by first writing two unlock cycles. This is followed by a third write cycle containing the unlock bypass command, 20h. The device then enters the unlock bypass mode. A two-cycle unlock bypass program command sequence is all that is required to program in this mode. The first cycle in this sequence contains the unlock bypass program command, A0h; the second cycle contains the program address and data. Additional data is programmed in the same manner. This mode dispenses with the initial two unlock cycles required in the standard program command sequence, resulting in faster total programming time. Tables 10 and 11 show the requirements for the command sequence.

During the unlock bypass mode, only the Unlock Bypass Program and Unlock Bypass Reset commands are valid. To exit the unlock bypass mode, the system must issue the two-cycle unlock bypass reset command sequence. The first cycle must contain the data 90h. The second cycle must contain the data 00h. The device then returns to the read mode.

### Write Buffer Programming

Write Buffer Programming allows the system write to a maximum of 16 words/32 bytes in one programming operation. This results in faster effective programming time than the standard programming algorithms. The Write Buffer Programming command sequence is initiated by first writing two unlock cycles. This is followed

by a third write cycle containing the Write Buffer Load command written at the Sector Address in which programming will occur. The fourth cycle writes the sector address and the number of word locations, minus one, to be programmed. For example, if the system will program 6 unique address locations, then 05h should be written to the device. This tells the device how many write buffer addresses will be loaded with data and therefore when to expect the Program Buffer to Flash command. The number of locations to program cannot exceed the size of the write buffer or the operation will abort.

The fifth cycle writes the first address location and data to be programmed. The write-buffer-page is selected by address bits  $A_{MAX}-A_4$ . All subsequent address/data pairs must fall within the selected-write-buffer-page. The system then writes the remaining address/data pairs into the write buffer. Write buffer locations may be loaded in any order.

The write-buffer-page address must be the same for all address/data pairs loaded into the write buffer. (This means Write Buffer Programming cannot be performed across multiple write-buffer pages. This also means that Write Buffer Programming cannot be performed across multiple sectors. If the system attempts to load programming data outside of the selected write-buffer page, the operation will abort.

Note that if a Write Buffer address location is loaded multiple times, the address/data pair counter will be decremented for every data load operation. The host system must therefore account for loading a write-buffer location more than once. The counter decrements for each data load operation, not for each unique write-buffer-address location. Note also that if an address location is loaded more than once into the buffer, the final data loaded for that address will be programmed.

Once the specified number of write buffer locations have been loaded, the system must then write the Program Buffer to Flash command at the sector address. Any other address and data combination aborts the Write Buffer Programming operation. The device then begins programming. Data polling should be used while monitoring the last address location loaded into the write buffer. DQ7, DQ6, DQ5, and DQ1 should be monitored to determine the device status during Write Buffer Programming.

The write-buffer programming operation can be suspended using the standard program suspend/resume commands. Upon successful completion of the Write Buffer Programming operation, the device is ready to execute the next command.

The Write Buffer Programming Sequence can be aborted in the following ways:

- Load a value that is greater than the page buffer size during the Number of Locations to Program step.
- Write to an address in a sector different than the one specified during the Write-Buffer-Load command.
- Write an Address/Data pair to a different write-buffer-page than the one selected by the Starting Address during the write buffer data loading stage of the operation.
- Write data other than the Confirm Command after the specified number of data load cycles.

The abort condition is indicated by  $DQ1 = 1$ ,  $DQ7 = \text{DATA\#}$  (for the last address location loaded),  $DQ6 = \text{toggle}$ , and  $DQ5=0$ . A Write-to-Buffer-Abort Reset command sequence must be written to reset the device for the next operation. Note that the full 3-cycle Write-to-Buffer-Abort Reset command sequence is re-

quired when using Write-Buffer-Programming features in Unlock Bypass mode.

### Accelerated Program

The device offers accelerated program operations through the WP#/ACC pin. When the system asserts  $V_{HH}$  on the WP#/ACC pin, the device automatically enters the Unlock Bypass mode. The system may then write the two-cycle Unlock Bypass program command sequence. The device uses the higher voltage on the WP#/ACC pin to accelerate the operation. *Note that the WP#/ACC pin must not be at  $V_{HH}$  for operations other than accelerated programming, or device damage may result. In addition, no external pullup is necessary since the WP#/ACC pin has internal pullup to  $V_{CC}$ .*

Figure 5 illustrates the algorithm for the program operation. Refer to the [Erase and Program Operations](#) table in the AC Characteristics section for parameters, and Figure 17 for timing diagrams.

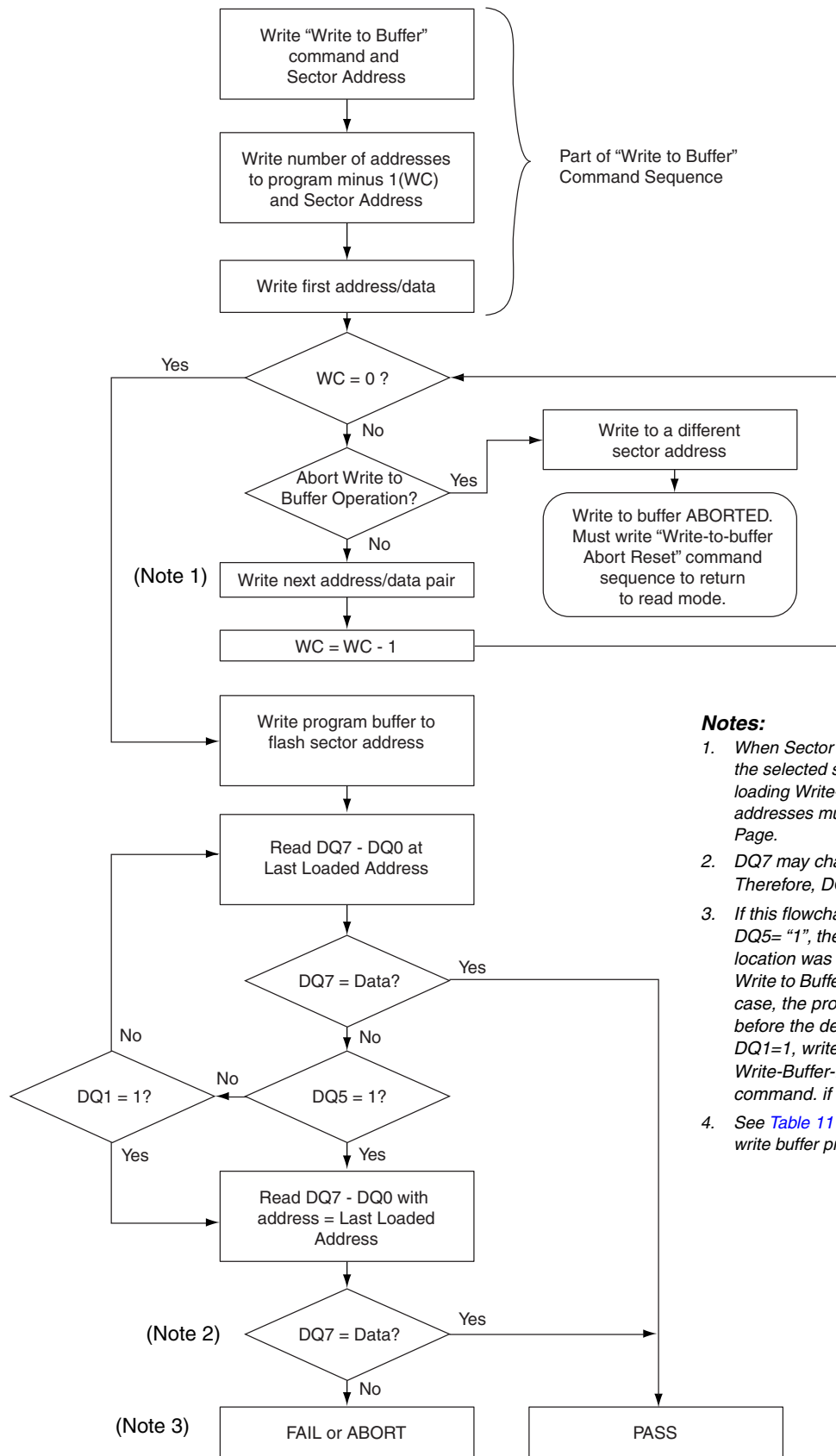

**Notes:**

1. When Sector Address is specified, any address in the selected sector is acceptable. However, when loading Write-Buffer address locations with data, all addresses must fall within the selected Write-Buffer Page.
2. DQ7 may change simultaneously with DQ5. Therefore, DQ7 should be verified.
3. If this flowchart location was reached because DQ5= "1", then the device FAILED. If this flowchart location was reached because DQ1= "1", then the Write to Buffer operation was ABORTED. In either case, the proper reset command must be written before the device can begin another operation. If DQ1=1, write the Write-Buffer-Programming-Abort-Reset command. if DQ5=1, write the Reset command.
4. See Table 11 for command sequences required for write buffer programming.

**Figure 4. Write Buffer Programming Operation**

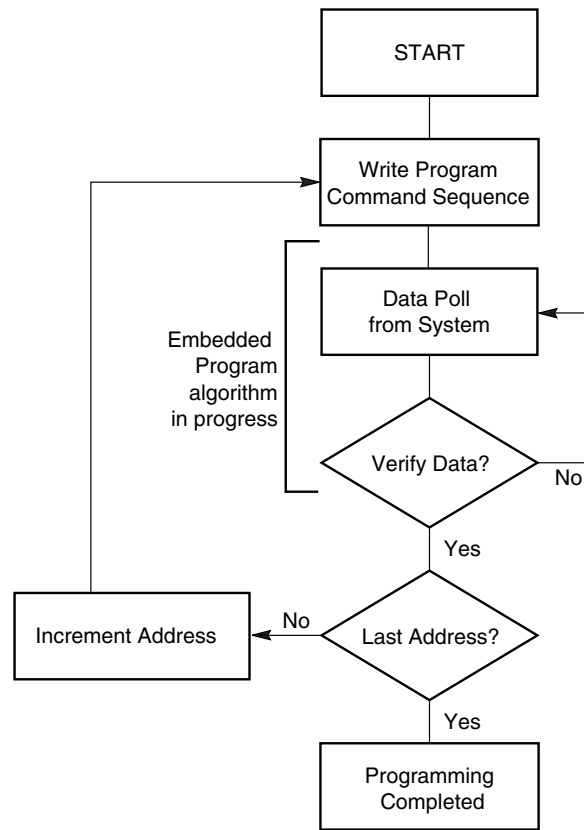

*Note:* See [Table 11](#) for program command sequence.

**Figure 5. Program Operation**

### Program Suspend/Program Resume Command Sequence

The Program Suspend command allows the system to interrupt a programming operation or a Write to Buffer programming operation so that data can be read from any non-suspended sector. When the Program Suspend command is written during a programming process, the device halts the program operation within 15  $\mu\text{s}$  maximum (5  $\mu\text{s}$  typical) and updates the status bits. Addresses are not required when writing the Program Suspend command.

After the programming operation has been suspended, the system can read array data from any non-suspended sector. The Program Suspend command may also be issued during a programming operation while an erase is suspended. In this case, data may be read from any addresses not in Erase Suspend or Program Suspend. If a read is needed from the SecSi Sector area (One-time Program area), then user must use the proper command sequences to enter and exit this region. *Note that the SecSi Sector,*

*autoselect, and CFI functions are unavailable when an program operation is in progress.*

The system may also write the autoselect command sequence when the device is in the Program Suspend mode. The system can read as many autoselect codes as required. When the device exits the autoselect mode, the device reverts to the Program Suspend mode, and is ready for another valid operation. See Autoselect Command Sequence for more information.

After the Program Resume command is written, the device reverts to programming. The system can determine the status of the program operation using the DQ7 or DQ6 status bits, just as in the standard program operation. See [Write Operation Status](#) for more information.

The system must write the Program Resume command (address bits are don't care) to exit the Program Suspend mode and continue the programming operation. Further writes of the Resume command are ignored. Another Program Suspend command can be written after the device has resume programming.

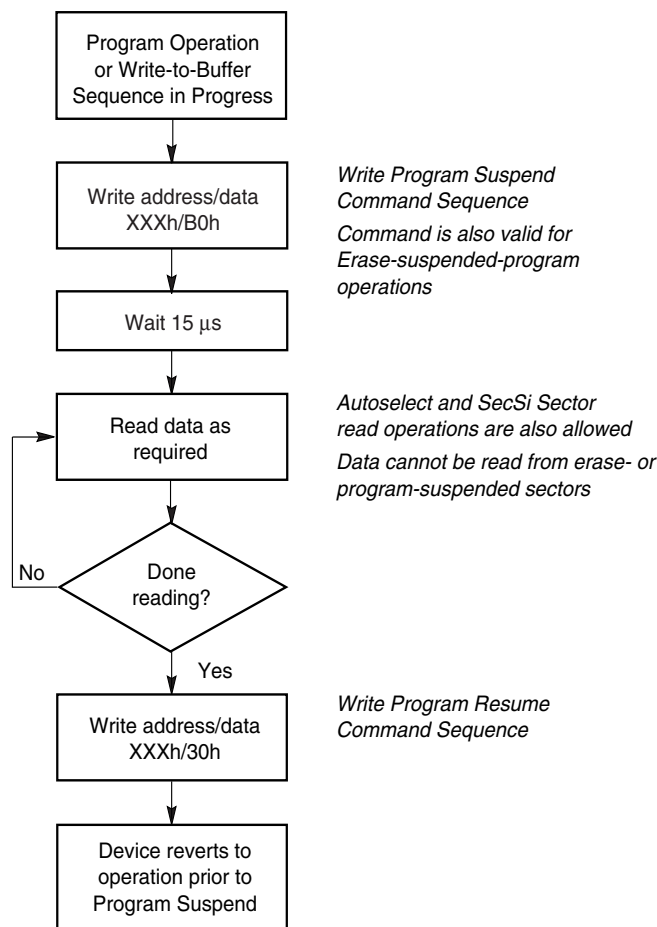

**Figure 6. Program Suspend/Program Resume**

## Chip Erase Command Sequence

Chip erase is a six bus cycle operation. The chip erase command sequence is initiated by writing two unlock cycles, followed by a set-up command. Two additional unlock write cycles are then followed by the chip erase command, which in turn invokes the Embedded Erase algorithm. The device does *not* require the system to preprogram prior to erase. The Embedded Erase algorithm automatically preprograms and verifies the entire memory for an all zero data pattern prior to electrical erase. The system is not required to provide any controls or timings during these operations. Tables 10 and 11 show the address and data requirements for the chip erase command sequence.

When the Embedded Erase algorithm is complete, the device returns to the read mode and addresses are no longer latched. The system can determine the status of the erase operation by using DQ7, DQ6, or DQ2. Refer to the [Write Operation Status](#) section for information on these status bits.

Any commands written during the chip erase operation are ignored. However, note that a **hardware reset** im-

mediately terminates the erase operation. If that occurs, the chip erase command sequence should be reinitiated once the device has returned to reading array data, to ensure data integrity. *Note that the SecSi Sector, autoselect, and CFI functions are unavailable when an erase operation is in progress.*

Figure 7 illustrates the algorithm for the erase operation. Refer to the [Erase and Program Operations](#) tables in the AC Characteristics section for parameters, and Figure 19 section for timing diagrams.

## Sector Erase Command Sequence

Sector erase is a six bus cycle operation. The sector erase command sequence is initiated by writing two unlock cycles, followed by a set-up command. Two additional unlock cycles are written, and are then followed by the address of the sector to be erased, and the sector erase command. Tables 10 and 11 show the address and data requirements for the sector erase command sequence.

The device does *not* require the system to preprogram prior to erase. The Embedded Erase algorithm automatically programs and verifies the entire memory for



an all zero data pattern prior to electrical erase. The system is not required to provide any controls or timings during these operations.

After the command sequence is written, a sector erase time-out of 50  $\mu$ s occurs. During the time-out period, additional sector addresses and sector erase commands may be written. Loading the sector erase buffer may be done in any sequence, and the number of sectors may be from one sector to all sectors. The time between these additional cycles must be less than 50  $\mu$ s, otherwise erasure may begin. Any sector erase address and command following the exceeded time-out may or may not be accepted. It is recommended that processor interrupts be disabled during this time to ensure all commands are accepted. The interrupts can be re-enabled after the last Sector Erase command is written. **Any command other than Sector Erase or Erase Suspend during the time-out period resets the device to the read mode.** The system must re-write the command sequence and any additional addresses and commands. *Note that the SecSi Sector, autoselect, and CFI functions are unavailable when an erase operation is in progress.*

The system can monitor DQ3 to determine if the sector erase timer has timed out (See the section on DQ3: Sector Erase Timer.). The time-out begins from the rising edge of the final WE# pulse in the command sequence.

When the Embedded Erase algorithm is complete, the device returns to reading array data and addresses are no longer latched. The system can determine the status of the erase operation by reading DQ7, DQ6, or DQ2 in the erasing sector. Refer to the [Write Operation Status](#) section for information on these status bits.

Once the sector erase operation has begun, only the Erase Suspend command is valid. All other commands are ignored. However, note that a **hardware reset** immediately terminates the erase operation. If that occurs, the sector erase command sequence should be reinitiated once the device has returned to reading array data, to ensure data integrity.

Figure 7 illustrates the algorithm for the erase operation. Refer to the [Erase and Program Operations](#) tables in the AC Characteristics section for parameters, and Figure 19 section for timing diagrams.

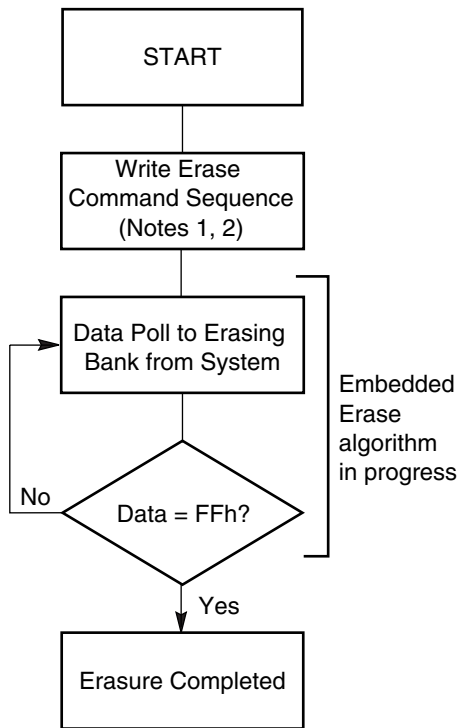

**Notes:**

1. See Tables 10 and 11 for erase command sequence.
2. See the section on DQ3 for information on the sector erase timer.

**Figure 7. Erase Operation**

## Erase Suspend/Erase Resume Commands

The Erase Suspend command, B0h, allows the system to interrupt a sector erase operation and then read data from, or program data to, any sector not selected for erasure. This command is valid only during the sector erase operation, including the 50  $\mu$ s time-out period during the sector erase command sequence. The Erase Suspend command is ignored if written during the chip erase operation or Embedded Program algorithm.

When the Erase Suspend command is written during the sector erase operation, the device requires a maximum of 20 (typical 5  $\mu$ s) to suspend the erase operation. However, when the Erase Suspend command is written during the sector erase time-out, the device immediately terminates the time-out period and suspends the erase operation.

After the erase operation has been suspended, the device enters the erase-suspend-read mode. The system can read data from or program data to any sector not selected for erasure. (The device “erase suspends” all sectors selected for erasure.) Reading at any address within erase-suspended sectors produces status information on DQ7–DQ0. The system can use DQ7, or DQ6 and DQ2 together, to determine if a sector is actively erasing or is erase-suspended. Refer to the [Write Operation Status](#) section for information on these status bits.

After an erase-suspended program operation is complete, the device returns to the erase-suspend-read mode. The system can determine the status of the program operation using the DQ7 or DQ6 status bits, just as in the standard word program operation. Refer to the [Write Operation Status](#) section for more information.

In the erase-suspend-read mode, the system can also issue the autoselect command sequence. Refer to the [Autoselect Mode](#) and [Autoselect Command Sequence](#) sections for details.

To resume the sector erase operation, the system must write the Erase Resume command. Further writes of the Resume command are ignored. Another Erase Suspend command can be written after the chip has resumed erasing.

*Note: During an erase operation, this flash device performs multiple internal operations which are invisible to the system. When an erase operation is suspended, any of the internal operations that were not fully completed must be restarted. As such, if this flash device is continually issued suspend/resume commands in rapid succession, erase progress will be impeded as a function of the number of suspends. The result will be a longer cumulative erase time than without suspends. Note that the additional suspends do not affect device reliability or future performance. In most systems rapid erase/suspend activity occurs only briefly. In such cases, erase performance will not be significantly impacted.*

## Command Definitions

**Table 8. Command Definitions (x16 Mode, BYTE# = V<sub>IH</sub>)**

Command Sequence (Note 1)		Cycles	Bus Cycles (Notes 2–5)											
			First		Second		Third		Fourth		Fifth		Sixth	
			Addr	Data	Addr	Data	Addr	Data	Addr	Data	Addr	Data	Addr	Data
Read (Note 5)		1	RA	RD										
Reset (Note 6)		1	XXX	F0										
Autoselect (Note 7)	Manufacturer ID	4	555	AA	2AA	55	555	90	X00	0001				
	Device ID (Note 8)	6	555	AA	2AA	55	555	90	X01	227E	X0E	220C	X0F	2201
	SecSi™ Sector Factory Protect (Note 9)	4	555	AA	2AA	55	555	90	X03	(Note 10)				
	Sector Group Protect Verify (Note 10)	4	555	AA	2AA	55	555	90	(SA)X02	00/01				
Enter SecSi Sector Region		3	555	AA	2AA	55	555	88						
Exit SecSi Sector Region		4	555	AA	2AA	55	555	90	XXX	00				
Program		4	555	AA	2AA	55	555	A0	PA	PD				
Write to Buffer (Note 11)		6	555	AA	2AA	55	SA	25	SA	WC	PA	PD	WBL	PD
Program Buffer to Flash		1	SA	29										
Write to Buffer Abort Reset (Note 12)		3	555	AA	2AA	55	555	F0						
Unlock Bypass		3	555	AA	2AA	55	555	20						
Unlock Bypass Program (Note 13)		2	XXX	A0	PA	PD								
Unlock Bypass Reset (Note 14)		2	XXX	90	XXX	00								
Chip Erase		6	555	AA	2AA	55	555	80	555	AA	2AA	55	555	10
Sector Erase		6	555	AA	2AA	55	555	80	555	AA	2AA	55	SA	30
Program/Erase Suspend (Note 15)		1	XXX	B0										
Program/Erase Resume (Note 16)		1	XXX	30										
CFI Query (Note 17)		1	55	98										

**Legend:**

X = Don't care

RA = Read Address of memory location to be read.

RD = Read Data read from location RA during read operation.

PA = Program Address . Addresses latch on falling edge of WE# or CE# pulse, whichever happens later.

PD = Program Data for location PA. Data latches on rising edge of WE# or CE# pulse, whichever happens first.

SA = Sector Address of sector to be verified (in autoselect mode) or erased. Address bits A21–A15 uniquely select any sector.

WBL = Write Buffer Location. Address must be within same write buffer page as PA.

WC = Word Count. Number of write buffer locations to load minus 1.

**Notes:**

- See [Table 1](#) for description of bus operations.
- All values are in hexadecimal.
- Shaded cells indicate read cycles. All others are write cycles.
- During unlock and command cycles, when lower address bits are 555 or 2AA as shown in table, address bits above A11 and data bits above DQ7 are don't care.
- No unlock or command cycles required when device is in read mode.
- Reset command is required to return to read mode (or to erase-suspend-read mode if previously in Erase Suspend) when device is in autoselect mode, or if DQ5 goes high while device is providing status information.
- Fourth cycle of the autoselect command sequence is a read cycle. Data bits DQ15–DQ8 are don't care. Except for RD, PD and WC. See [Autoselect Command Sequence](#) section for more information.
- Device ID must be read in three cycles.
- If WP# protects highest address sector, data is 98h for factory locked and 18h for not factory locked. If WP# protects lowest address sector, data is 88h for factory locked and 08h for not factory locked.
- Data is 00h for an unprotected sector group and 01h for a protected sector group.
- Total number of cycles in command sequence is determined by number of words written to write buffer. Maximum number of cycles in command sequence is 21, including "Program Buffer to Flash" command.
- Command sequence resets device for next command after aborted write-to-buffer operation.
- Unlock Bypass command is required prior to Unlock Bypass Program command.
- Unlock Bypass Reset command is required to return to read mode when device is in unlock bypass mode.
- System may read and program in non-erasing sectors, or enter autoselect mode, when in Erase Suspend mode. Erase Suspend command is valid only during a sector erase operation.
- Erase Resume command is valid only during Erase Suspend mode.

Table 9. Command Definitions (x8 Mode, BYTE# = V<sub>IL</sub>)

Command Sequence (Note 1)	Cycles	Bus Cycles (Notes 2–5)											
		First		Second		Third		Fourth		Fifth		Sixth	
		Addr	Data	Addr	Data	Addr	Data	Addr	Data	Addr	Data	Addr	Data
Read (Note 6)	1	RA	RD										
Reset (Note 7)	1	XXX	F0										
Autoselect (Note 8)	Manufacturer ID	4	AAA	AA	555	55	AAA	90	X00	01			
	Device ID (Note 9)	6	AAA	AA	555	55	AAA	90	X02	7E	X1C	0C	X1E 01
	SecSi™ Sector Factory Protect (Note 10)	4	AAA	AA	555	55	AAA	90	X06	(Note 10)			
	Sector Group Protect Verify (Note 11)	4	AAA	AA	555	55	AAA	90	(SA)X04	00/01			
Enter SecSi Sector Region	3	AAA	AA	555	55	AAA	88						
Exit SecSi Sector Region	4	AAA	AA	555	55	AAA	90	XXX	00				
Program	4	AAA	AA	555	55	AAA	A0	PA	PD				
Write to Buffer (Note 12)	6	AAA	AA	555	55	SA	25	SA	BC	PA	PD	WBL PD	
Program Buffer to Flash	1	SA	29										
Write to Buffer Abort Reset (Note 13)	3	AAA	AA	555	55	AAA	F0						
Unlock Bypass	3	AAA	AA	555	55	AAA	20						
Unlock Bypass Program (Note 14)	2	XXX	A0	PA	PD								
Unlock Bypass Reset (Note 15)	2	XXX	90	XXX	00								
Chip Erase	6	AAA	AA	555	55	AAA	80	AAA	AA	555	55	AAA 10	
Sector Erase	6	AAA	AA	555	55	AAA	80	AAA	AA	555	55	SA 30	
Program/Erase Suspend (Note 16)	1	XXX	B0										
Program/Erase Resume (Note 17)	1	XXX	30										
CFI Query (Note 18)	1	AA	98										

**Legend:**

X = Don't care

RA = Read Address of memory location to be read.

RD = Read Data read from location RA during read operation.

PA = Program Address. Addresses latch on falling edge of WE# or CE# pulse, whichever happens later.

PD = Program Data for location PA. Data latches on rising edge of WE# or CE# pulse, whichever happens first.

SA = Sector Address of sector to be verified (in autoselect mode) or erased. Address bits A21–A15 uniquely select any sector.

WBL = Write Buffer Location. Address must be within same write buffer page as PA.

BC = Byte Count. Number of write buffer locations to load minus 1.

**Notes:**

- See Table 1 for description of bus operations.
- All values are in hexadecimal.
- Shaded cells indicate read cycles. All others are write cycles.
- During unlock and command cycles, when lower address bits are 555 or AAA as shown in table, address bits above A11 are don't care.
- Unless otherwise noted, address bits A21–A11 are don't cares.
- No unlock or command cycles required when device is in read mode.
- Reset command is required to return to read mode (or to erase-suspend-read mode if previously in Erase Suspend) when device is in autoselect mode, or if DQ5 goes high while device is providing status information.
- Fourth cycle of autoselect command sequence is a read cycle. Data bits DQ15–DQ8 are don't care. See Autoselect Command Sequence section or more information.
- Device ID must be read in three cycles.

- If WP# protects highest address sector, data is 98h for factory locked and 18h for not factory locked. If WP# protects lowest address sector, data is 88h for factory locked and 08h for not factory locked.
- Data is 00h for an unprotected sector group and 01h for a protected sector group.
- Total number of cycles in command sequence is determined by number of bytes written to write buffer. Maximum number of cycles in command sequence is 37, including "Program Buffer to Flash" command.
- Command sequence resets device for next command after aborted write-to-buffer operation.
- Unlock Bypass command is required prior to Unlock Bypass Program command.
- Unlock Bypass Reset command is required to return to read mode when device is in unlock bypass mode.
- System may read and program in non-erasing sectors, or enter autoselect mode, when in Erase Suspend mode. Erase Suspend command is valid only during a sector erase operation.
- Erase Resume command is valid only during Erase Suspend mode.

## WRITE OPERATION STATUS

The device provides several bits to determine the status of a program or erase operation: DQ2, DQ3, DQ5, DQ6, and DQ7. [Table 12](#) and the following subsections describe the function of these bits. DQ7 and DQ6 each offer a method for determining whether a program or erase operation is complete or in progress. The device also provides a hardware-based output signal, RY/BY#, to determine whether an Embedded Program or Erase operation is in progress or has been completed.

### DQ7: Data# Polling

The Data# Polling bit, DQ7, indicates to the host system whether an Embedded Program or Erase algorithm is in progress or completed, or whether the device is in Erase Suspend. Data# Polling is valid after the rising edge of the final WE# pulse in the command sequence.

During the Embedded Program algorithm, the device outputs on DQ7 the complement of the datum programmed to DQ7. This DQ7 status also applies to programming during Erase Suspend. When the Embedded Program algorithm is complete, the device outputs the datum programmed to DQ7. The system must provide the program address to read valid status information on DQ7. If a program address falls within a protected sector, Data# Polling on DQ7 is active for approximately 1  $\mu$ s, then the device returns to the read mode.

During the Embedded Erase algorithm, Data# Polling produces a “0” on DQ7. When the Embedded Erase

algorithm is complete, or if the device enters the Erase Suspend mode, Data# Polling produces a “1” on DQ7. The system must provide an address within any of the sectors selected for erasure to read valid status information on DQ7.

After an erase command sequence is written, if all sectors selected for erasing are protected, Data# Polling on DQ7 is active for approximately 100  $\mu$ s, then the device returns to the read mode. If not all selected sectors are protected, the Embedded Erase algorithm erases the unprotected sectors, and ignores the selected sectors that are protected. However, if the system reads DQ7 at an address within a protected sector, the status may not be valid.

Just prior to the completion of an Embedded Program or Erase operation, DQ7 may change asynchronously with DQ0–DQ6 while Output Enable (OE#) is asserted low. That is, the device may change from providing status information to valid data on DQ7. Depending on when the system samples the DQ7 output, it may read the status or valid data. Even if the device has completed the program or erase operation and DQ7 has valid data, the data outputs on DQ0–DQ6 may be still invalid. Valid data on DQ0–DQ7 will appear on successive read cycles.

[Table 12](#) shows the outputs for Data# Polling on DQ7. [Figure 8](#) shows the Data# Polling algorithm. [Figure 20](#) in the [AC Characteristics](#) section shows the Data# Polling timing diagram.

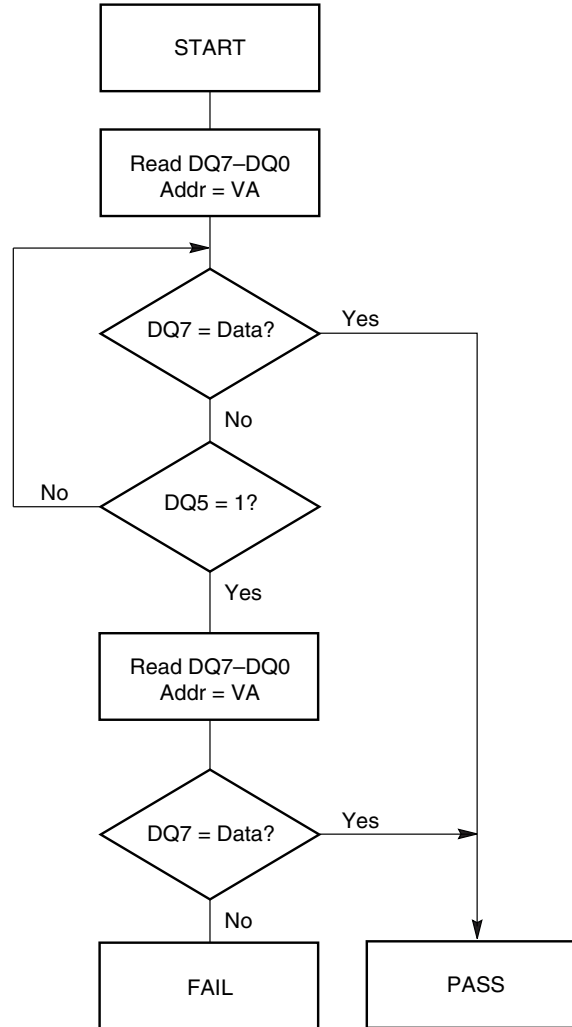
**Notes:**

1. *VA = Valid address for programming. During a sector erase operation, a valid address is any sector address within the sector being erased. During chip erase, a valid address is any non-protected sector address.*
2. *DQ7 should be rechecked even if DQ5 = "1" because DQ7 may change simultaneously with DQ5.*

**Figure 8. Data# Polling Algorithm**

### **RY/BY#: Ready/Busy#**

The RY/BY# is a dedicated, open-drain output pin which indicates whether an Embedded Algorithm is in progress or complete. The RY/BY# status is valid after the rising edge of the final WE# pulse in the command sequence. Since RY/BY# is an open-drain output, several RY/BY# pins can be tied together in parallel with a pull-up resistor to  $V_{CC}$ .

If the output is low (Busy), the device is actively erasing or programming. (This includes programming in the Erase Suspend mode.) If the output is high (Ready), the device is in the read mode, the standby mode, or in the erase-suspend-read mode. [Table 12](#) shows the outputs for RY/BY#.

### **DQ6: Toggle Bit I**

Toggle Bit I on DQ6 indicates whether an Embedded Program or Erase algorithm is in progress or complete, or whether the device has entered the Erase Suspend mode. Toggle Bit I may be read at any address, and is valid after the rising edge of the final WE# pulse in the command sequence (prior to the program or erase operation), and during the sector erase time-out.

During an Embedded Program or Erase algorithm operation, successive read cycles to any address cause DQ6 to toggle. The system may use either OE# or CE# to control the read cycles. When the operation is complete, DQ6 stops toggling.

After an erase command sequence is written, if all sectors selected for erasing are protected, DQ6 toggles for approximately 100  $\mu$ s, then returns to reading array data. If not all selected sectors are protected, the Embedded Erase algorithm erases the unprotected sectors, and ignores the selected sectors that are protected.

The system can use DQ6 and DQ2 together to determine whether a sector is actively erasing or is erase-suspended. When the device is actively erasing (that is, the Embedded Erase algorithm is in progress), DQ6 toggles. When the device enters the Erase Suspend mode, DQ6 stops toggling. However, the system must also use DQ2 to determine which sectors are erasing or erase-suspended. Alternatively, the system can use DQ7 (see the subsection on [DQ7: Data# Polling](#)).

If a program address falls within a protected sector, DQ6 toggles for approximately 1  $\mu$ s after the program command sequence is written, then returns to reading array data.

DQ6 also toggles during the erase-suspend-program mode, and stops toggling once the Embedded Program algorithm is complete.

[Table 12](#) shows the outputs for Toggle Bit I on DQ6. Figure 9 shows the toggle bit algorithm. Figure 21 in the “AC Characteristics” section shows the toggle bit timing diagrams. Figure 22 shows the differences between DQ2 and DQ6 in graphical form. See also the subsection on [DQ2: Toggle Bit II](#).

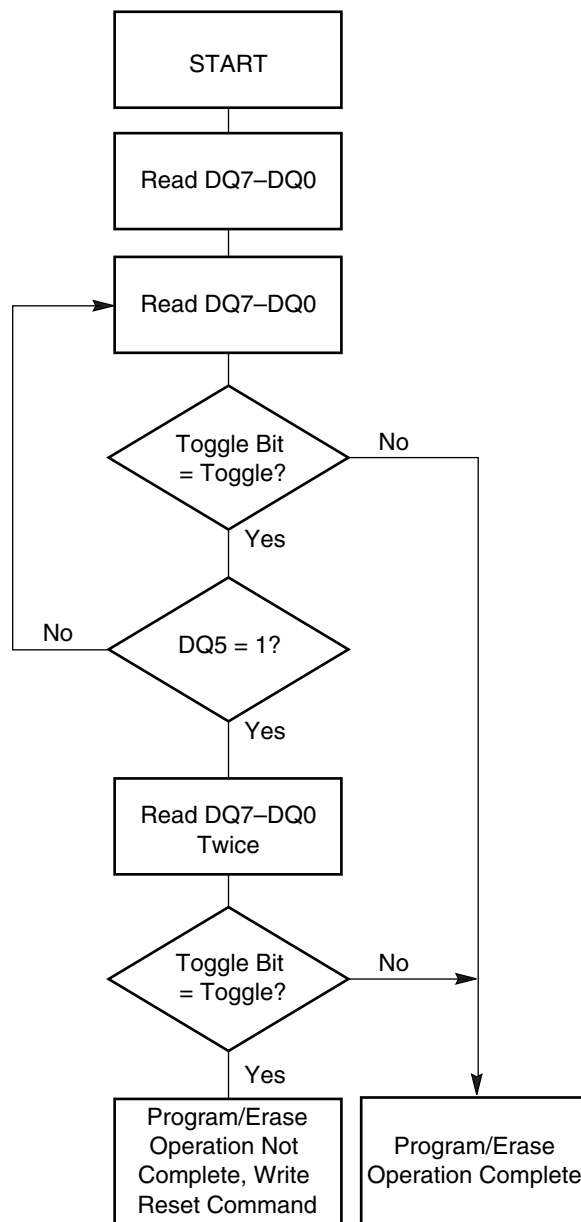

**Note:** The system should recheck the toggle bit even if  $DQ5 = "1"$  because the toggle bit may stop toggling as  $DQ5$  changes to "1." See the subsections on  $DQ6$  and  $DQ2$  for more information.

**Figure 9. Toggle Bit Algorithm**

## DQ2: Toggle Bit II

The "Toggle Bit II" on  $DQ2$ , when used with  $DQ6$ , indicates whether a particular sector is actively erasing (that is, the Embedded Erase algorithm is in progress), or whether that sector is erase-suspended. Toggle Bit II is valid after the rising edge of the final  $WE\#$  pulse in the command sequence.

$DQ2$  toggles when the system reads at addresses within those sectors that have been selected for erasure. (The system may use either  $OE\#$  or  $CE\#$  to control the read cycles.) But  $DQ2$  cannot distinguish

whether the sector is actively erasing or is erase-suspended.  $DQ6$ , by comparison, indicates whether the device is actively erasing, or is in Erase Suspend, but cannot distinguish which sectors are selected for erasure. Thus, both status bits are required for sector and mode information. Refer to [Table 12](#) to compare outputs for  $DQ2$  and  $DQ6$ .

Figure 9 shows the toggle bit algorithm in flowchart form, and the section "DQ2: Toggle Bit II" explains the algorithm. See also the [RY/BY#: Ready/Busy#](#) subsection. Figure 21 shows the toggle bit timing diagram.



Figure 22 shows the differences between DQ2 and DQ6 in graphical form.

### Reading Toggle Bits DQ6/DQ2

Refer to Figure 9 for the following discussion. Whenever the system initially begins reading toggle bit status, it must read DQ7–DQ0 at least twice in a row to determine whether a toggle bit is toggling. Typically, the system would note and store the value of the toggle bit after the first read. After the second read, the system would compare the new value of the toggle bit with the first. If the toggle bit is not toggling, the device has completed the program or erase operation. The system can read array data on DQ7–DQ0 on the following read cycle.

However, if after the initial two read cycles, the system determines that the toggle bit is still toggling, the system also should note whether the value of DQ5 is high (see the section on DQ5). If it is, the system should then determine again whether the toggle bit is toggling, since the toggle bit may have stopped toggling just as DQ5 went high. If the toggle bit is no longer toggling, the device has successfully completed the program or erase operation. If it is still toggling, the device did not complete the operation successfully, and the system must write the reset command to return to reading array data.

The remaining scenario is that the system initially determines that the toggle bit is toggling and DQ5 has not gone high. The system may continue to monitor the toggle bit and DQ5 through successive read cycles, determining the status as described in the previous paragraph. Alternatively, it may choose to perform other system tasks. In this case, the system must start at the beginning of the algorithm when it returns to determine the status of the operation (top of Figure 9).

### DQ5: Exceeded Timing Limits

DQ5 indicates whether the program, erase, or write-to-buffer time has exceeded a specified internal pulse count limit. Under these conditions DQ5 produces a “1,” indicating that the program or erase cycle was not successfully completed.

The device may output a “1” on DQ5 if the system tries to program a “1” to a location that was previously pro-

grammed to “0.” **Only an erase operation can change a “0” back to a “1.”** Under this condition, the device halts the operation, and when the timing limit has been exceeded, DQ5 produces a “1.”

In all these cases, the system must write the reset command to return the device to the reading the array (or to erase-suspend-read if the device was previously in the erase-suspend-program mode).

### DQ3: Sector Erase Timer

After writing a sector erase command sequence, the system may read DQ3 to determine whether or not erasure has begun. (The sector erase timer does not apply to the chip erase command.) If additional sectors are selected for erasure, the entire time-out also applies after each additional sector erase command. When the time-out period is complete, DQ3 switches from a “0” to a “1.” If the time between additional sector erase commands from the system can be assumed to be less than 50  $\mu$ s, the system need not monitor DQ3. See also the [Sector Erase Command Sequence](#) section.

After the sector erase command is written, the system should read the status of DQ7 (Data# Polling) or DQ6 (Toggle Bit I) to ensure that the device has accepted the command sequence, and then read DQ3. If DQ3 is “1,” the Embedded Erase algorithm has begun; all further commands (except Erase Suspend) are ignored until the erase operation is complete. If DQ3 is “0,” the device will accept additional sector erase commands. To ensure the command has been accepted, the system software should check the status of DQ3 prior to and following each subsequent sector erase command. If DQ3 is high on the second status check, the last command might not have been accepted.

[Table 12](#) shows the status of DQ3 relative to the other status bits.

### DQ1: Write-to-Buffer Abort

DQ1 indicates whether a Write-to-Buffer operation was aborted. Under these conditions DQ1 produces a “1”. The system must issue the Write-to-Buffer-Abort-Reset command sequence to return the device to reading array data. See [Write Buffer Programming](#) section for more details.

Table 10. Write Operation Status

Status		DQ7 (Note 2)	DQ6	DQ5 (Note 1)	DQ3	DQ2 (Note 2)	DQ1	RY/BY#
Standard Mode	Embedded Program Algorithm	DQ7#	Toggle	0	N/A	No toggle	0	0
	Embedded Erase Algorithm	0	Toggle	0	1	Toggle	N/A	0
Program Suspend Mode	Program-Suspend Sector	Invalid (not allowed)						1
	Non-Program Suspend Sector	Data						1
Erase Suspend Mode	Erase-Suspend Sector	1	No toggle	0	N/A	Toggle	N/A	1
	Non-Erase Suspend Sector	Data						1
	Erase-Suspend-Program (Embedded Program)	DQ7#	Toggle	0	N/A	N/A	N/A	0
Write-to-Buffer	Busy (Note 3)	DQ7#	Toggle	0	N/A	N/A	0	0
	Abort (Note 4)	DQ7#	Toggle	0	N/A	N/A	1	0

**Notes:**

1. DQ5 switches to '1' when an Embedded Program, Embedded Erase, or Write-to-Buffer operation has exceeded the maximum timing limits. Refer to the section on DQ5 for more information.
2. DQ7 and DQ2 require a valid address when reading status information. Refer to the appropriate subsection for further details.
3. The Data# Polling algorithm should be used to monitor the last loaded write-buffer address location.
4. DQ1 switches to '1' when the device has aborted the write-to-buffer operation.

### ABSOLUTE MAXIMUM RATINGS

Storage Temperature, Plastic Packages .....	-65°C to +150°C
Ambient Temperature with Power Applied .....	-65°C to +125°C
Voltage with Respect to Ground	
$V_{CC}$ (Note 1) .....	-0.5 V to +4.0 V
$V_{IO}$ .....	-0.5 V to +4.0 V
A9, OE#, ACC, and RESET# (Note 2) .....	-0.5 V to +12.5 V
All other pins (Note 1) .....	-0.5 V to $V_{CC} + 0.5$ V
Output Short Circuit Current (Note 3) .....	200 mA

**Notes:**

1. Minimum DC voltage on input or I/O pins is -0.5 V. During voltage transitions, input or I/O pins may overshoot  $V_{SS}$  to -2.0 V for periods of up to 20 ns. Maximum DC voltage on input or I/O pins is  $V_{CC} + 0.5$  V. See Figure 10. During voltage transitions, input or I/O pins may overshoot to  $V_{CC} + 2.0$  V for periods up to 20 ns. See Figure 11.
2. Minimum DC input voltage on pins A9, OE#, ACC, and RESET# is -0.5 V. During voltage transitions, A9, OE#, ACC, and RESET# may overshoot  $V_{SS}$  to -2.0 V for periods of up to 20 ns. See Figure 10. Maximum DC input voltage on pin A9, OE#, ACC, and RESET# is +12.5 V which may overshoot to +14.0 V for periods up to 20 ns.
3. No more than one output may be shorted to ground at a time. Duration of the short circuit should not be greater than one second.

Stresses above those listed under "Absolute Maximum Ratings" may cause permanent damage to the device. This is a stress rating only; functional operation of the device at these or any other conditions above those indicated in the operational sections of this data sheet is not implied. Exposure of the device to absolute maximum rating conditions for extended periods may affect device reliability.

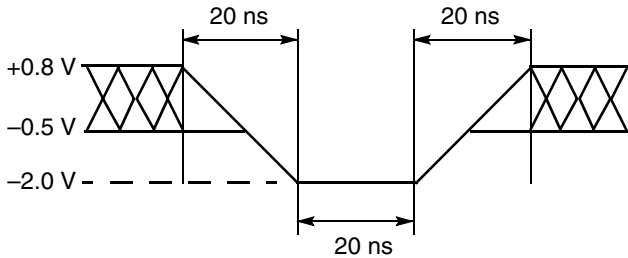

**Figure 10. Maximum Negative Overshoot Waveform**

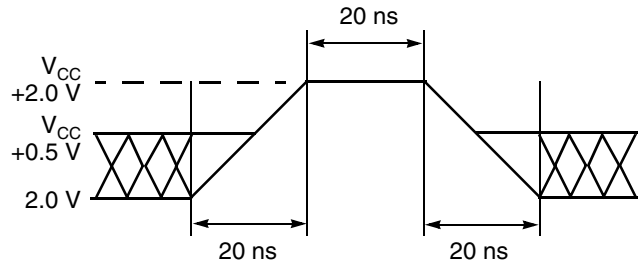

**Figure 11. Maximum Positive Overshoot Waveform**

### OPERATING RANGES

**Industrial (I) Devices**

Ambient Temperature ( $T_A$ ) .....	-40°C to +85°C
-------------------------------------	----------------

**Supply Voltages**

$V_{CC}$ .....	2.7-3.6 V
$V_{IO}$ (Note 2) .....	1.65-3.6 V

**Notes:**

1. Operating ranges define those limits between which the functionality of the device is guaranteed.
2. See [Ordering Information](#) section for valid  $V_{CC}/V_{IO}$  range combinations. The I/Os will not operate at 3 V when  $V_{IO} = 1.8$  V.

## DC CHARACTERISTICS

## CMOS Compatible

Parameter Symbol	Parameter Description (Notes)	Test Conditions	Min	Typ	Max	Unit
$I_{LI}$	Input Load Current (1)	$V_{IN} = V_{SS}$ to $V_{CC}$ , $V_{CC} = V_{CC\ max}$			$\pm 1.0$	$\mu A$
$I_{LIT}$	A9, ACC Input Load Current	$V_{CC} = V_{CC\ max}$ ; A9 = 12.5 V			35	$\mu A$
$I_{LR}$	Reset Leakage Current	$V_{CC} = V_{CC\ max}$ ; RESET# = 12.5 V			35	$\mu A$
$I_{LO}$	Output Leakage Current	$V_{OUT} = V_{SS}$ to $V_{CC}$ , $V_{CC} = V_{CC\ max}$			$\pm 1.0$	$\mu A$
$I_{CC1}$	$V_{CC}$ Active Read Current (2, 3)	CE# = $V_{IL}$ , OE# = $V_{IH}$ ,	5 MHz	15	20	mA
			1 MHz	15	20	
$I_{CC2}$	$V_{CC}$ Initial Page Read Current (2, 3)	CE# = $V_{IL}$ , OE# = $V_{IH}$		30	50	mA
$I_{CC3}$	$V_{CC}$ Intra-Page Read Current (2, 3)	CE# = $V_{IL}$ , OE# = $V_{IH}$		10	20	mA
$I_{CC4}$	$V_{CC}$ Active Write Current (3, 4)	CE# = $V_{IL}$ , OE# = $V_{IH}$		50	60	mA
$I_{CC5}$	$V_{CC}$ Standby Current (3)	CE#, RESET# = $V_{CC} \pm 0.3$ V, WP# = $V_{IH}$		1	5	$\mu A$
$I_{CC6}$	$V_{CC}$ Reset Current (3)	RESET# = $V_{SS} \pm 0.3$ V, WP# = $V_{IH}$		1	5	$\mu A$
$I_{CC7}$	Automatic Sleep Mode (3, 5)	$V_{IH} = V_{CC} \pm 0.3$ V; $V_{IL} = V_{SS} \pm 0.3$ V, WP# = $V_{IH}$		1	5	$\mu A$
$V_{IL1}$	Input Low Voltage 1(6, 7)		-0.5		0.8	V
$V_{IH1}$	Input High Voltage 1 (6, 7)		1.9		$V_{CC} + 0.5$	V
$V_{IL2}$	Input Low Voltage 2 (6, 8)		-0.5		$0.3 \times V_{IO}$	V
$V_{IH2}$	Input High Voltage 2 (6, 8)		1.9		$V_{IO} + 0.5$	V
$V_{HH}$	Voltage for ACC Program Acceleration	$V_{CC} = 2.7 - 3.6$ V	11.5		12.5	V
$V_{ID}$	Voltage for Autoselect and Temporary Sector Unprotect	$V_{CC} = 2.7 - 3.6$ V	11.5		12.5	V
$V_{OL}$	Output Low Voltage (9)	$I_{OL} = 4.0$ mA, $V_{CC} = V_{CC\ min} = V_{IO}$			$0.15 \times V_{IO}$	V
$V_{OH1}$	Output High Voltage	$I_{OH} = -2.0$ mA, $V_{CC} = V_{CC\ min} = V_{IO}$	$0.85 V_{IO}$			V
$V_{OH2}$		$I_{OH} = -100$ $\mu A$ , $V_{CC} = V_{CC\ min} = V_{IO}$	$V_{IO} - 0.4$			V
$V_{LKO}$	Low $V_{CC}$ Lock-Out Voltage (10)		2.3		2.5	V

**Notes:**

- On the WP#/ACC pin only, the maximum input load current when WP# =  $V_{IL}$  is  $\pm 5.0$   $\mu A$ .
- The  $I_{CC}$  current listed is typically less than 2 mA/MHz, with OE# at  $V_{IH}$ .
- Maximum  $I_{CC}$  specifications are tested with  $V_{CC} = V_{CC\ max}$ .
- $I_{CC}$  active while Embedded Erase or Embedded Program is in progress.
- Automatic sleep mode enables the low power mode when addresses remain stable for  $t_{ACC} + 30$  ns.
- If  $V_{IO} < V_{CC}$ , maximum  $V_{IL}$  for CE# and DQ I/Os is  $0.3 V_{IO}$ . If  $V_{IO} < V_{CC}$ , minimum  $V_{IH}$  for CE# and DQ I/Os is  $0.7 V_{IO}$ . Maximum  $V_{IH}$  for these connections is  $V_{IO} + 0.3$  V.
- $V_{CC}$  voltage requirements.
- $V_{IO}$  voltage requirements.
- Includes RY/BY#
- Not 100% tested.

TEST CONDITIONS

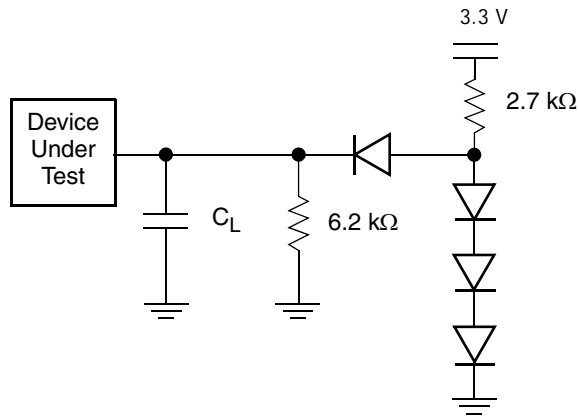

Table 11. Test Specifications

Test Condition	All Speeds	Unit
Output Load	1 TTL gate	
Output Load Capacitance, $C_L$ (including jig capacitance)	30	pF
Input Rise and Fall Times	5	ns
Input Pulse Levels	0.0–3.0	V
Input timing measurement reference levels (See Note)	1.5	V
Output timing measurement reference levels	$0.5 V_{IO}$	V

Note: If  $V_{IO} < V_{CC}$ , the reference level is  $0.5 V_{IO}$ .

Note: Diodes are IN3064 or equivalent

Figure 12. Test Setup

KEY TO SWITCHING WAVEFORMS

WAVEFORM	INPUTS	OUTPUTS
		Steady
		Changing from H to L
		Changing from L to H
	Don't Care, Any Change Permitted	Changing, State Unknown
	Does Not Apply	Center Line is High Impedance State (High Z)

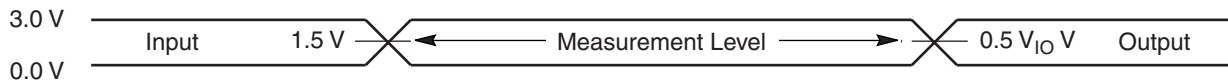

Note: If  $V_{IO} < V_{CC}$ , the input measurement reference level is  $0.5 V_{IO}$ .

Figure 13. Input Waveforms and Measurement Levels

AC CHARACTERISTICS

Read-Only Operations

Parameter		Description	Test Setup		Speed Options						Unit
JEDEC	Std.				90R	101, 101R	112R	112	120R	120	
$t_{AVAV}$	$t_{RC}$	Read Cycle Time (Note 1)		Min	90	100	110		120		ns
$t_{AVQV}$	$t_{ACC}$	Address to Output Delay	CE#, OE# = $V_{IL}$	Max	90	100	110		120		ns
$t_{ELQV}$	$t_{CE}$	Chip Enable to Output Delay	OE# = $V_{IL}$	Max	90	100	110		120		ns
	$t_{PACC}$	Page Access Time		Max	25	30	30	40	30	40	ns
$t_{GLQV}$	$t_{OE}$	Output Enable to Output Delay		Max	25	30	30	40	30	40	ns
$t_{EHQZ}$	$t_{DF}$	Chip Enable to Output High Z (Note 1)		Max	16						ns
$t_{GHQZ}$	$t_{DF}$	Output Enable to Output High Z (Note 1)		Max	16						ns
$t_{AXQX}$	$t_{OH}$	Output Hold Time From Addresses, CE# or OE#, Whichever Occurs First		Min	0						ns
	$t_{OEh}$	Output Enable Hold Time (Note 1)	Read	Min	0						ns
		Toggle and Data# Polling		Min	10						ns

Notes:

1. Not 100% tested.
2. See Figure 12 and Table 13 for test specifications.
3. AC Specifications listed are tested with  $V_{IO} = V_{CC}$ . Contact AMD for information on AC operation with  $V_{IO} \neq V_{CC}$ .

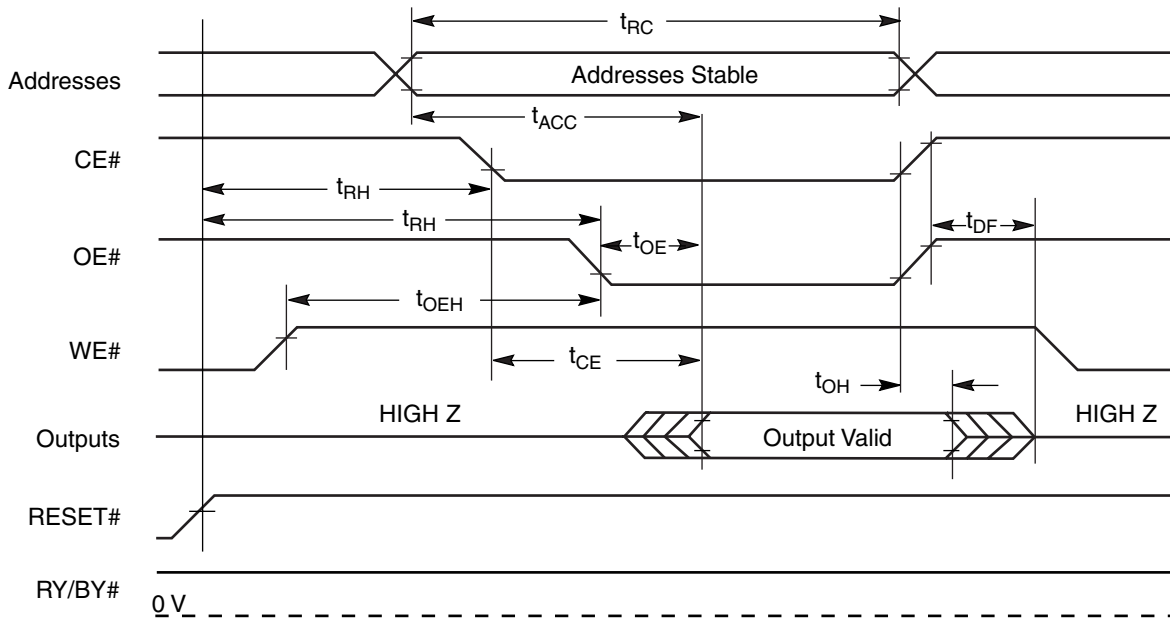
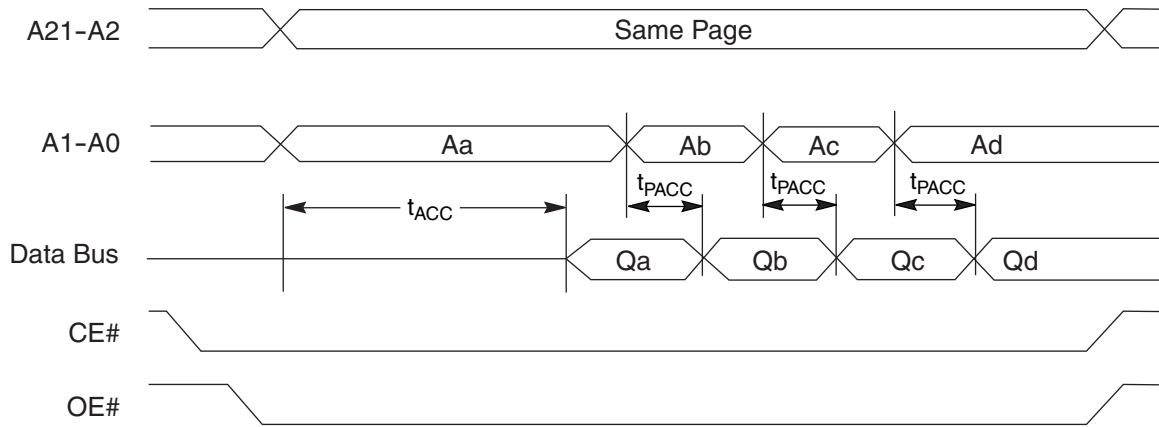

Figure 14. Read Operation Timings

AC CHARACTERISTICS



\* Figure shows device in word mode. Addresses are A1–A-1 for byte mode.

**Figure 15. Page Read Timings**

AC CHARACTERISTICS

Hardware Reset (RESET#)

Parameter		Description		All Speed Options	Unit
JEDEC	Std.				
	$t_{Ready}$	RESET# Pin Low (During Embedded Algorithms) to Read Mode (See Note)	Max	20	$\mu$ s
	$t_{Ready}$	RESET# Pin Low (NOT During Embedded Algorithms) to Read Mode (See Note)	Max	500	ns
	$t_{RP}$	RESET# Pulse Width	Min	500	ns
	$t_{RH}$	Reset High Time Before Read (See Note)	Min	50	ns
	$t_{RPD}$	RESET# Input Low to Standby Mode	Min	20	$\mu$ s
	$t_{RB}$	RY/BY# Output High to CE#, OE# pin Low	Min	0	ns

Notes:

1. Not 100% tested.
2. AC Specifications listed are tested with  $V_{IO} = V_{CC}$ . Contact AMD for information on AC operation with  $V_{IO} \neq V_{CC}$ .

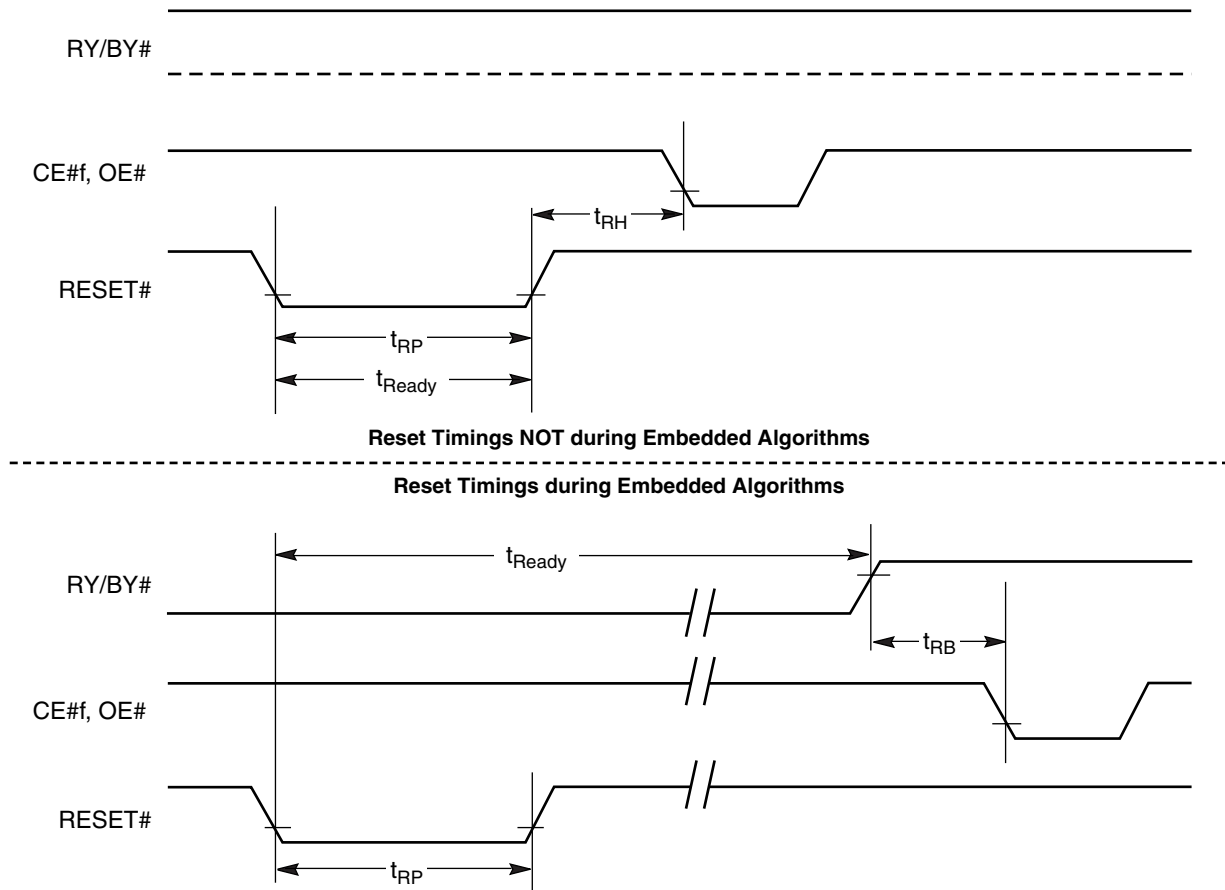

Figure 16. Reset Timings



## AC CHARACTERISTICS

### Erase and Program Operations

Parameter		Description		Speed Options				Unit
JEDEC	Std.			90R	101, 101R	112, 112R	120, 120R	
$t_{AVAV}$	$t_{WC}$	Write Cycle Time (Note 1)	Min	90	100	110	120	ns
$t_{AVWL}$	$t_{AS}$	Address Setup Time	Min	0				ns
	$t_{ASO}$	Address Setup Time to OE# low during toggle bit polling	Min	15				ns
$t_{WLAX}$	$t_{AH}$	Address Hold Time	Min	45				ns
	$t_{AHT}$	Address Hold Time From CE# or OE# high during toggle bit polling	Min	0				ns
$t_{DVWH}$	$t_{DS}$	Data Setup Time	Min	45				ns
$t_{WHDX}$	$t_{DH}$	Data Hold Time	Min	0				ns
	$t_{OEPH}$	Output Enable High during toggle bit polling	Min	20				ns
$t_{GHWL}$	$t_{GHWL}$	Read Recovery Time Before Write (OE# High to WE# Low)	Min	0				ns
$t_{ELWL}$	$t_{CS}$	CE# Setup Time	Min	0				ns
$t_{WHEH}$	$t_{CH}$	CE# Hold Time	Min	0				ns
$t_{WLWH}$	$t_{WP}$	Write Pulse Width	Min	35				ns
$t_{WHDL}$	$t_{WPH}$	Write Pulse Width High	Min	30				ns
$t_{WHWH1}$	$t_{WHWH1}$	Write Buffer Program Operation (Notes 2, 3)		Typ	352			$\mu$ s
		Effective Write Buffer Program Operation (Notes 2, 4)	Per Byte	Typ	11			$\mu$ s
			Per Word	Typ	22			$\mu$ s
		Accelerated Effective Write Buffer Program Operation (Notes 2, 4)	Per Byte	Typ	8.8			$\mu$ s
			Per Word	Typ	17.6			$\mu$ s
		Single Word/Byte Program Operation (Note 2, 5)	Byte	Typ	100			$\mu$ s
Word	100				$\mu$ s			
		Single Word/Byte Accelerated Programming Operation (Note 2, 5)	Byte	Typ	90			$\mu$ s
			Word		90			$\mu$ s
$t_{WHWH2}$	$t_{WHWH2}$	Sector Erase Operation (Note 2)	Typ	0.5			sec	
	$t_{VHH}$	$V_{HH}$ Rise and Fall Time (Note 1)	Min	250				ns
	$t_{VCS}$	$V_{CC}$ Setup Time (Note 1)	Min	50				$\mu$ s
	$t_{BUSY}$	WE# High to RY/BY# Low	Min	90	100	110	120	ns
	$t_{POLL}$	Program Valid Before Status Polling (Note 7)	Max	4				$\mu$ s

**Notes:**

- Not 100% tested.
- See the "Erase and Programming Performance" section for more information.
- For 1–16 words/1–32 bytes programmed.
- Effective write buffer specification is based upon a 16-word/32-byte write buffer operation.
- Word/Byte programming specification is based upon a single word/byte programming operation not utilizing the write buffer.
- AC Specifications listed are tested with  $V_{IO} = V_{CC}$ . Contact AMD for information on AC operation with  $V_{IO} \neq V_{CC}$ .
- When using the program suspend/resume feature, if the suspend command is issued within  $t_{POLL}$ ,  $t_{POLL}$  must be fully re-applied upon resuming the programming operation. If the suspend command is issued after  $t_{POLL}$ ,  $t_{POLL}$  is not required again prior to reading the status bits upon resuming.

AC CHARACTERISTICS

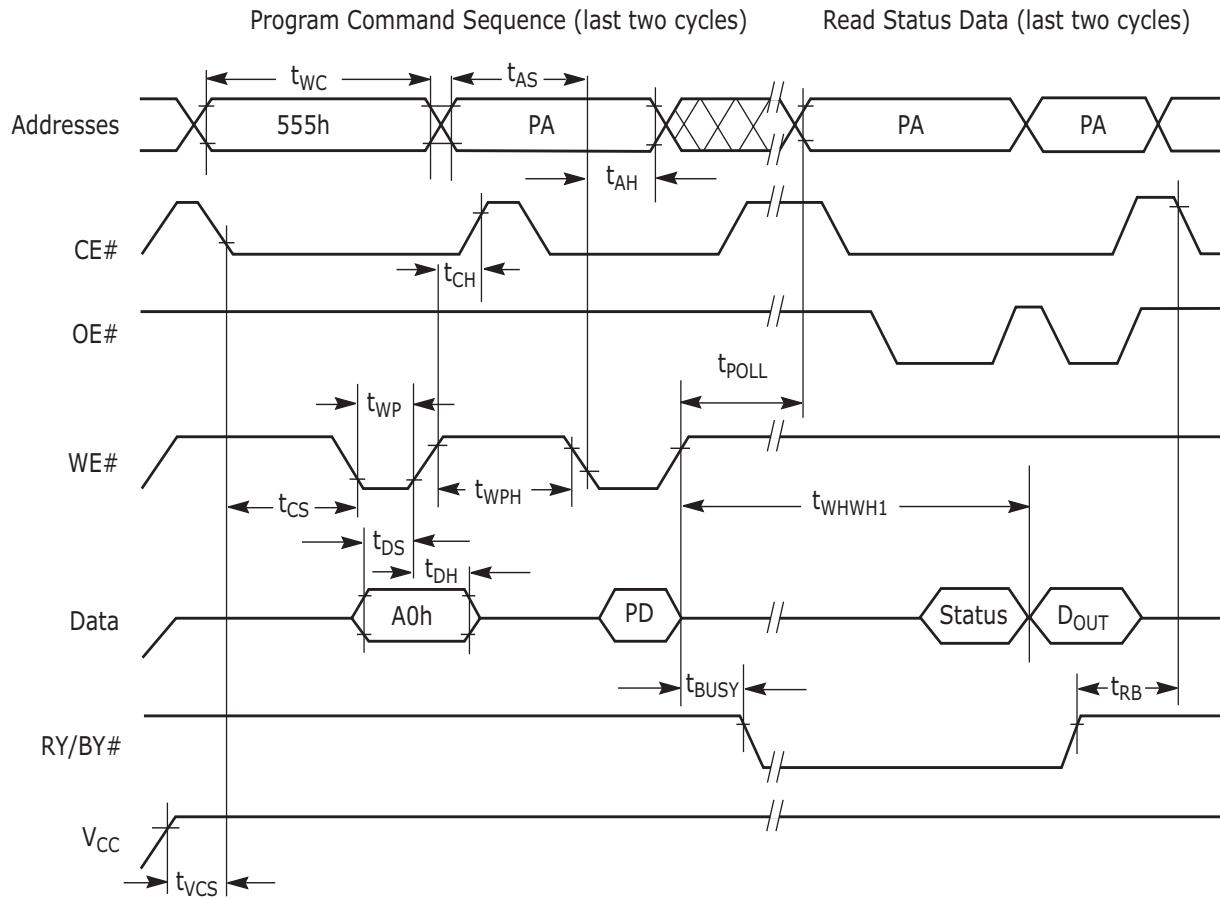

Notes:

- 1. PA = program address, PD = program data,  $D_{OUT}$  is the true data at the program address. ILLUSTRATION SHOWS DEVICE IN WORD MODE.

Figure 17. Program Operation Timings

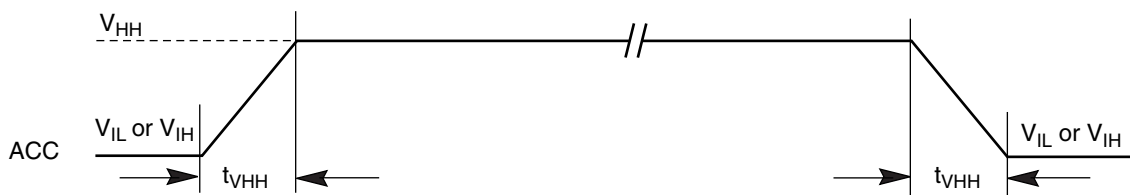
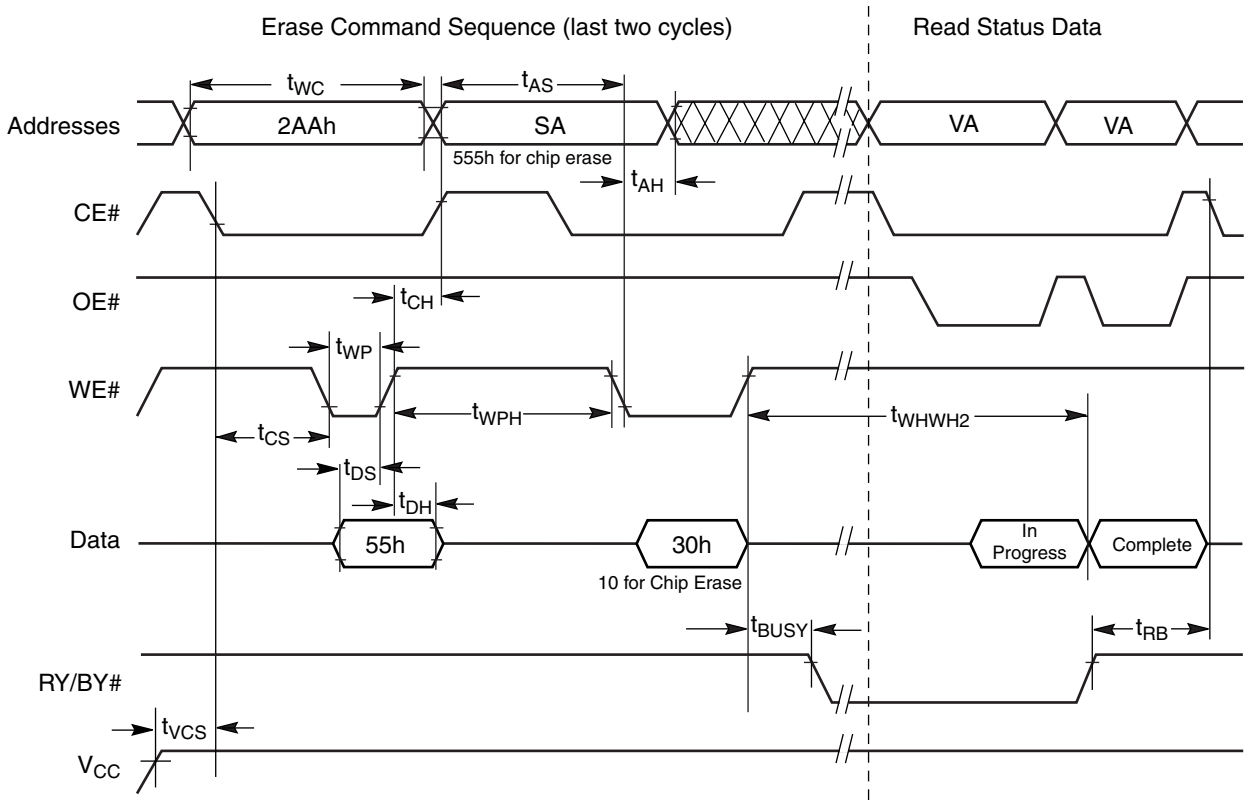

Figure 18. Accelerated Program Timing Diagram

AC CHARACTERISTICS



Notes:

1. SA = sector address (for Sector Erase), VA = Valid Address for reading status data (see "Write Operation Status").
2. Illustration shows device in word mode.

Figure 19. Chip/Sector Erase Operation Timings

AC CHARACTERISTICS

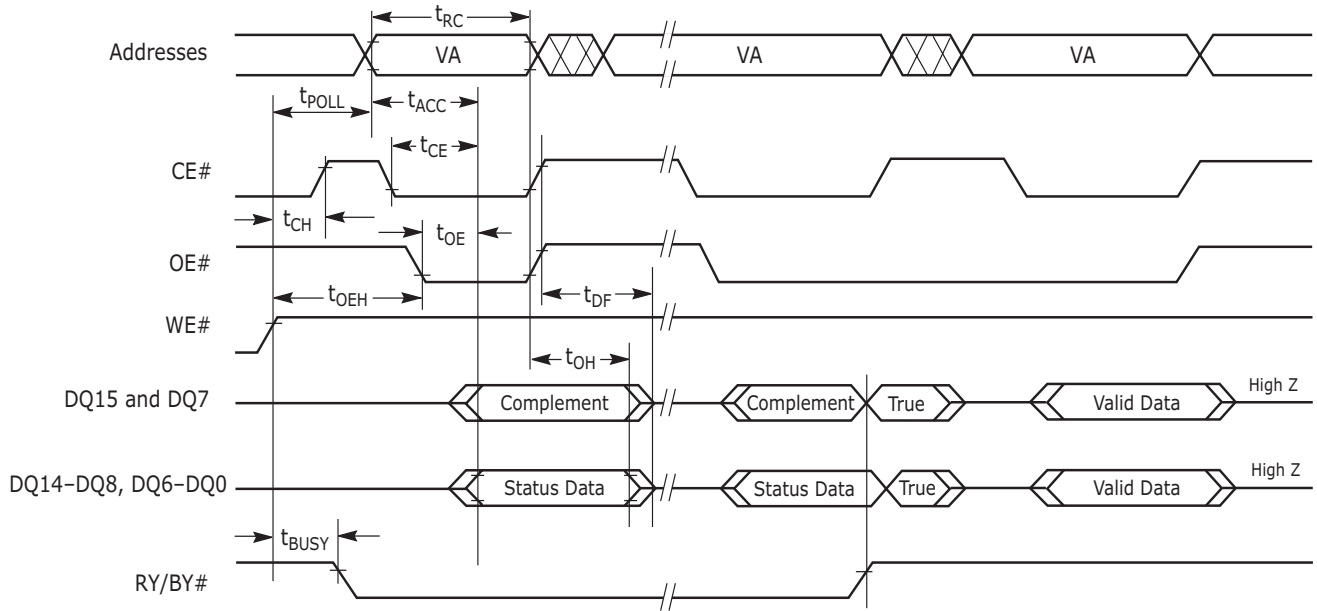

**Note:** VA = Valid address. Illustration shows first status cycle after command sequence, last status read cycle, and array data read cycle.

**Figure 20. Data# Polling Timings (During Embedded Algorithms)**

AC CHARACTERISTICS

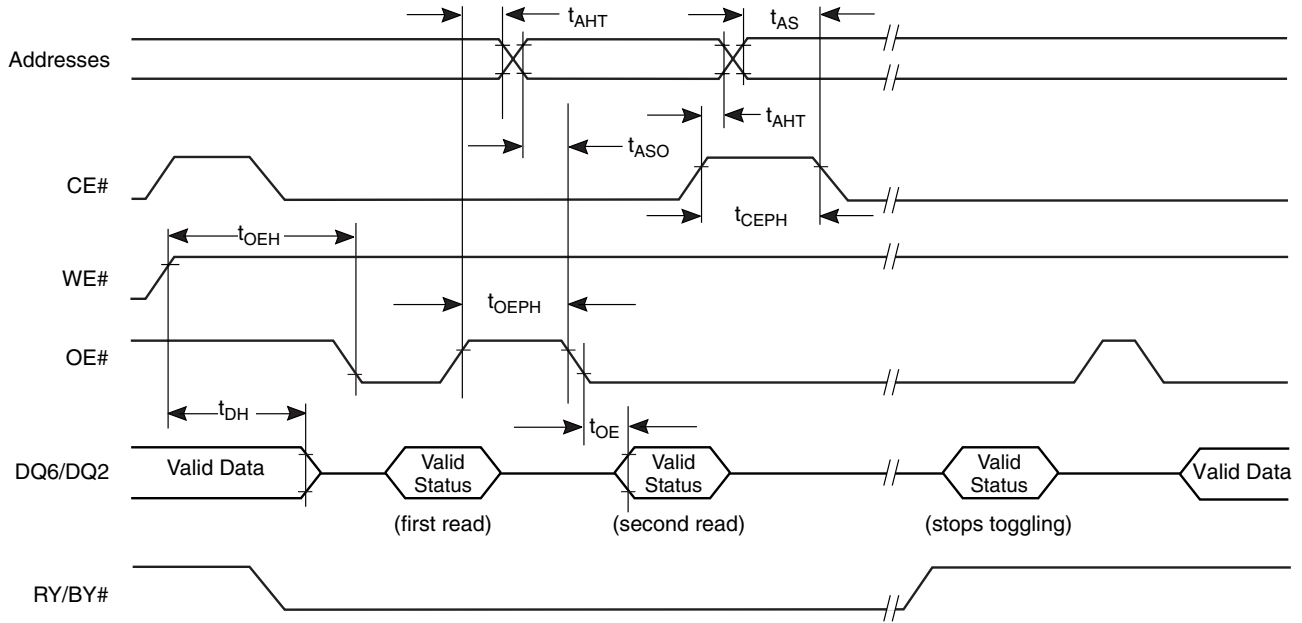

**Note:** VA = Valid address; not required for DQ6. Illustration shows first two status cycle after command sequence, last status read cycle, and array data read cycle.

**Figure 21. Toggle Bit Timings (During Embedded Algorithms)**

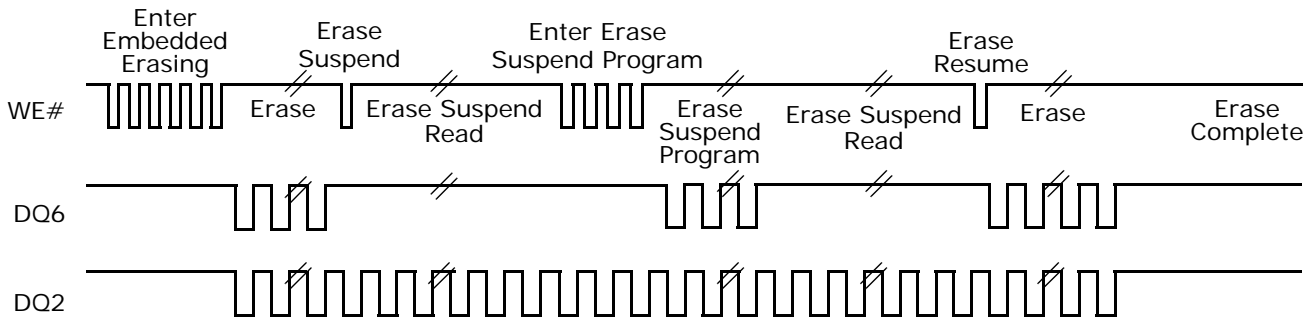

**Note:** DQ2 toggles only when read at an address within an erase-suspended sector. The system may use OE# or CE# to toggle DQ2 and DQ6.

**Figure 22. DQ2 vs. DQ6**

AC CHARACTERISTICS

Temporary Sector Unprotect

Parameter		Description		All Speed Options	Unit
JEDEC	Std				
	$t_{VIDR}$	$V_{ID}$ Rise and Fall Time (See Note)	Min	500	ns
	$t_{RSP}$	RESET# Setup Time for Temporary Sector Unprotect	Min	4	$\mu$ s

Notes:

1. Not 100% tested.
2. AC Specifications listed are tested with  $V_{IO} = V_{CC}$ . Contact AMD for information on AC operation with  $V_{IO} \neq V_{CC}$ .

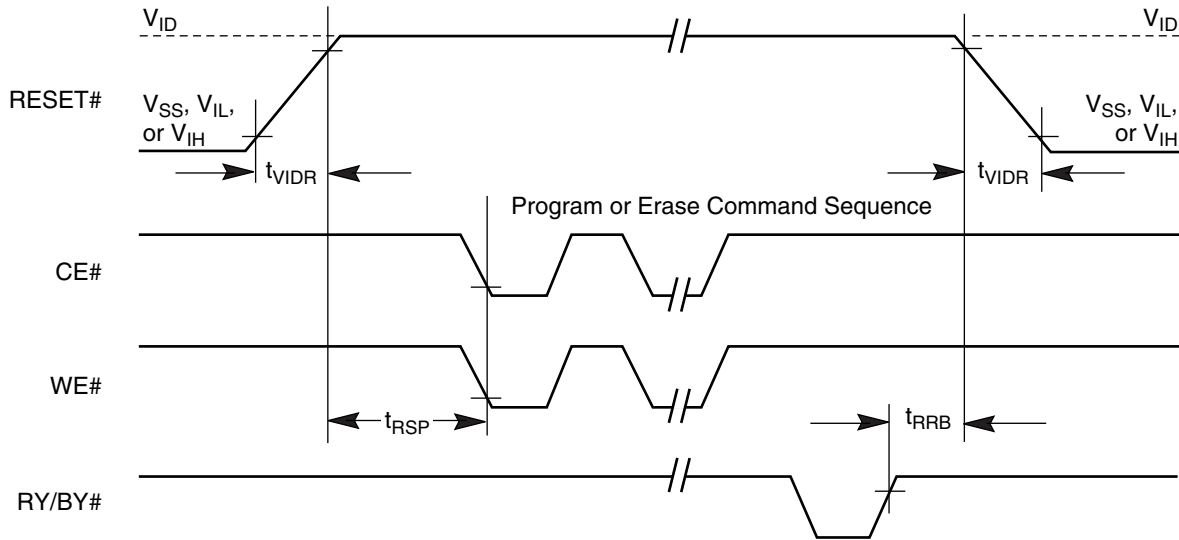
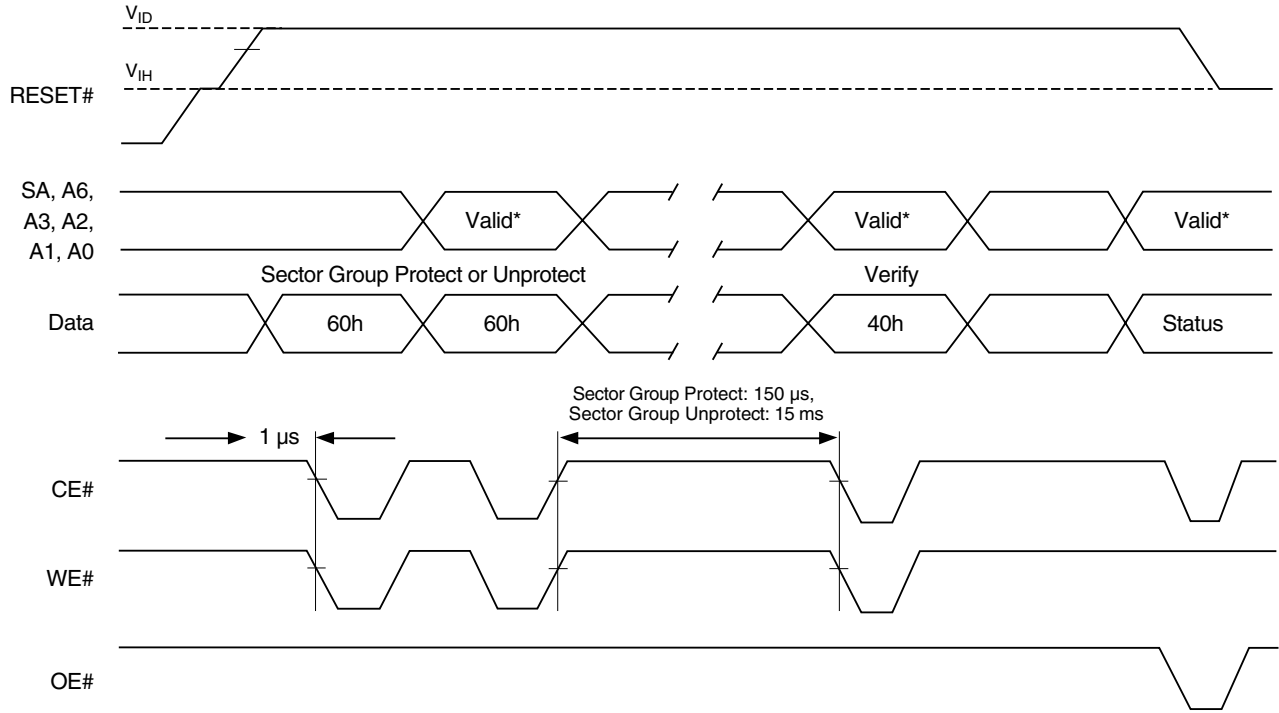

Figure 23. Temporary Sector Group Unprotect Timing Diagram

AC CHARACTERISTICS



**Note:** For sector group protect, A6:A0 = 0xx0010. For sector group unprotect, A6:A0 = 1xx0010.N

**Figure 24. Sector Group Protect and Unprotect Timing Diagram**

## AC CHARACTERISTICS

## Alternate CE# Controlled Erase and Program Operations

Parameter		Description		Speed Options				Unit	
JEDEC	Std.			90R	101, 101R	112, 112R	120, 120R		
$t_{AVAV}$	$t_{WC}$	Write Cycle Time (Note 1)	Min	90	100	110	120	ns	
$t_{AVWL}$	$t_{AS}$	Address Setup Time	Min	0				ns	
$t_{ELAX}$	$t_{AH}$	Address Hold Time	Min	45				ns	
$t_{DVEH}$	$t_{DS}$	Data Setup Time	Min	45				ns	
$t_{EHDX}$	$t_{DH}$	Data Hold Time	Min	0				ns	
$t_{GHLEL}$	$t_{GHLEL}$	Read Recovery Time Before Write (OE# High to WE# Low)	Min	0				ns	
$t_{WLEL}$	$t_{WS}$	WE# Setup Time	Min	0				ns	
$t_{EHWH}$	$t_{WH}$	WE# Hold Time	Min	0				ns	
$t_{ELEH}$	$t_{CP}$	CE# Pulse Width	Min	45				ns	
$t_{EHEL}$	$t_{CPH}$	CE# Pulse Width High	Min	30				ns	
$t_{WHWH1}$	$t_{WHWH1}$	Write Buffer Program Operation (Notes 2, 3)	Typ	352				$\mu$ s	
		Effective Write Buffer Program Operation (Notes 2, 4)	Per Byte	Typ	11				$\mu$ s
			Per Word	Typ	22				$\mu$ s
		Accelerated Effective Write Buffer Program Operation (Notes 2, 4)	Per Byte	Typ	8.8				$\mu$ s
			Per Word	Typ	17.6				$\mu$ s
		Single Word/Byte Program Operation (Note 2, 5)	Byte	Typ	100				$\mu$ s
			Word		100				$\mu$ s
Single Word/Byte Accelerated Programming Operation (Note 2, 5)	Byte	Typ	90				$\mu$ s		
	Word		90				$\mu$ s		
$t_{WHWH2}$	$t_{WHWH2}$	Sector Erase Operation (Note 7)	Typ	0.5				sec	
	$t_{RH}$	RESET# High Time Before Write	Min	50				ns	
	$t_{POLL}$	Program Valid Before Status Polling (Note 7)	Max	4				$\mu$ s	

**Notes:**

1. Not 100% tested.
2. See the "Erase and Programming Performance" section for more information.
3. For 1–16 words/1–32 bytes programmed.
4. Effective write buffer specification is based upon a 16-word/32-byte write buffer operation.
5. Word/Byte programming specification is based upon a single word/byte programming operation not utilizing the write buffer.
6. AC Specifications listed are tested with  $V_{IO} = V_{CC}$ . Contact AMD for information on AC operation with  $V_{IO} \neq V_{CC}$ .
7. When using the program suspend/resume feature, if the suspend command is issued within  $t_{POLL}$ ,  $t_{POLL}$  must be fully re-applied upon resuming the programming operation. If the suspend command is issued after  $t_{POLL}$ ,  $t_{POLL}$  is not required again prior to reading the status bits upon resuming.



# AC Characteristics

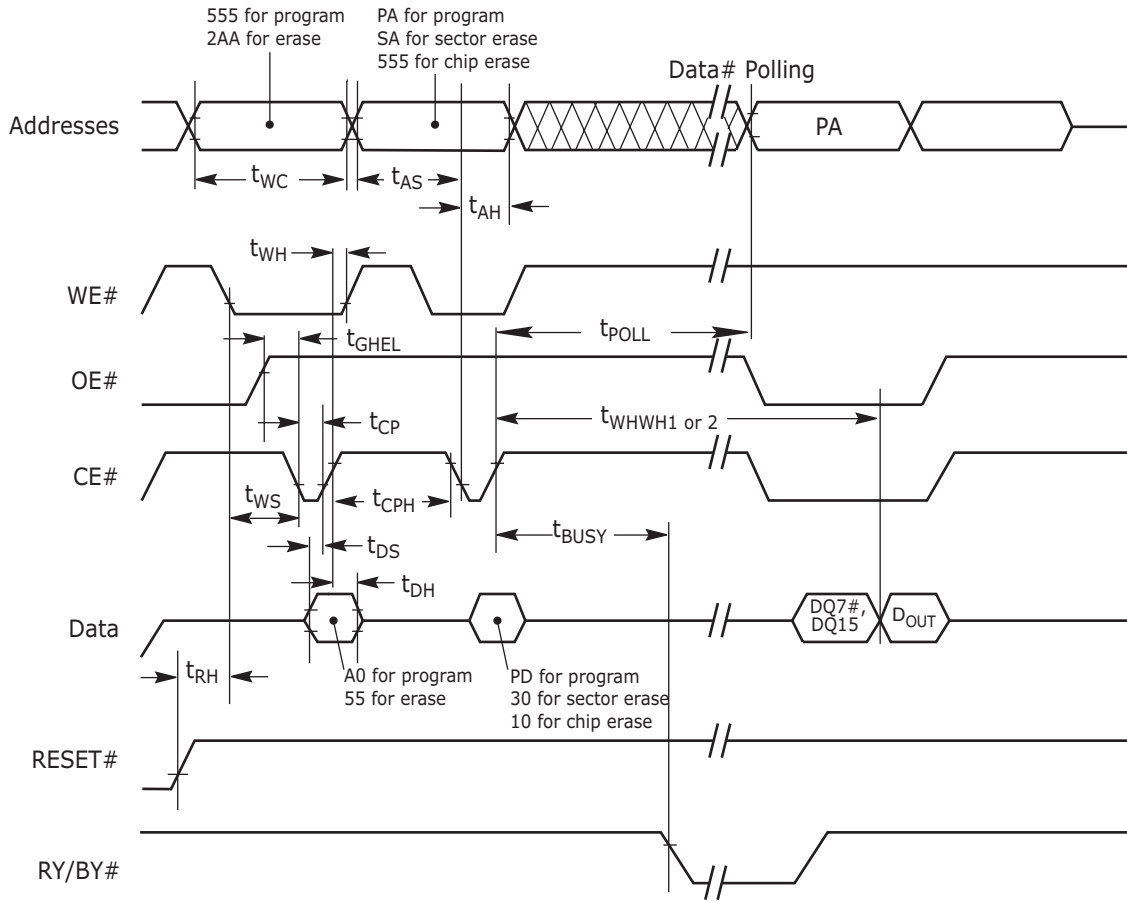

**Notes:**

1. Figure indicates last two bus cycles of a program or erase operation.
2. PA = program address, SA = sector address, PD = program data.
3. DQ7# is the complement of the data written to the device. D<sub>OUT</sub> is the data written to the device.
4. Illustration shows device in word mode.

**Figure 25. Alternate CE# Controlled Write (Erase/Program) Operation Timings**

## ERASE AND PROGRAMMING PERFORMANCE

Parameter		Typ (Note 1)	Max (Note 2)	Unit	Comments
Sector Erase Time		0.5	15	sec	Excludes 00h programming prior to erasure (Note 6)
Chip Erase Time		64	128	sec	
Single Word/Byte Program Time (Note 3)	Byte	100	800	$\mu$ s	Excludes system level overhead (Note 7)
	Word	100	800	$\mu$ s	
Accelerated Single Word/Byte Program Time (Note 3)	Byte	90	720	$\mu$ s	
	Word	90	720	$\mu$ s	
Total Write Buffer Program Time (Note 4)		352	1800	$\mu$ s	
Effective Write Buffer Program Time (Note 5)	Per Byte	11	57	$\mu$ s	
	Per Word	22	113	$\mu$ s	
Total Accelerated Effective Write Buffer Program Time (Note 4)		282	1560	$\mu$ s	
Effective Accelerated Write Buffer Program Time (Note 4)	Per Byte	8.8	49	$\mu$ s	
	Per Word	17.6	98	$\mu$ s	
Chip Program Time, using the Write Buffer		92	170	sec	

**Notes:**

1. Typical program and erase times assume the following conditions: 25°C, 3.0 V  $V_{CC}$ . Programming specifications assume that all bits are programmed to 00h.
2. Maximum values are measured at  $V_{CC} = 3.0$  V, worst case temperature. Maximum values are valid up to and including 100,000 program/erase cycles.
3. Word/Byte programming specification is based upon a single word/byte programming operation not utilizing the write buffer.
4. For 1-16 words or 1-32 bytes programmed in a single write buffer programming operation.
5. Effective write buffer specification is calculated on a per-word/per-byte basis for a 16-word/32-byte write buffer operation.
6. In the pre-programming step of the Embedded Erase algorithm, all bits are programmed to 00h before erasure.
7. System-level overhead is the time required to execute the command sequence(s) for the program command. See Tables 8 and 9 for further information on command definitions.
8. The device has a minimum erase and program cycle endurance of 100,000 cycles.

## LATCHUP CHARACTERISTICS

Description	Min	Max
Input voltage with respect to $V_{SS}$ on all pins except I/O pins (including A9, OE#, and RESET#)	-1.0 V	12.5 V
Input voltage with respect to $V_{SS}$ on all I/O pins	-1.0 V	$V_{CC} + 1.0$ V
$V_{CC}$ Current	-100 mA	+100 mA

**Note:** Includes all pins except  $V_{CC}$ . Test conditions:  $V_{CC} = 3.0$  V, one pin at a time.

## TSOP PIN AND BGA PACKAGE CAPACITANCE

Parameter Symbol	Parameter Description	Test Setup	Typ	Max	Unit	
$C_{IN}$	Input Capacitance	$V_{IN} = 0$	TSOP	6	7.5	pF
			Fine-pitch BGA	4.2	5.0	pF
$C_{OUT}$	Output Capacitance	$V_{OUT} = 0$	TSOP	8.5	12	pF
			Fine-pitch BGA	5.4	6.5	pF
$C_{IN2}$	Control Pin Capacitance	$V_{IN} = 0$	TSOP	7.5	9	pF
			Fine-pitch BGA	3.9	4.7	pF

**Notes:**

1. Sampled, not 100% tested.
2. Test conditions  $T_A = 25^\circ\text{C}$ ,  $f = 1.0$  MHz.

## DATA RETENTION

Parameter Description	Test Conditions	Min	Unit
Minimum Pattern Data Retention Time	150°C	10	Years
	125°C	20	Years

PHYSICAL DIMENSIONS

TS056/TSR056—56-Pin Standard and Reverse Pinout Thin Small Outline Package (TSOP)

STANDARD PIN OUT (TOP VIEW)

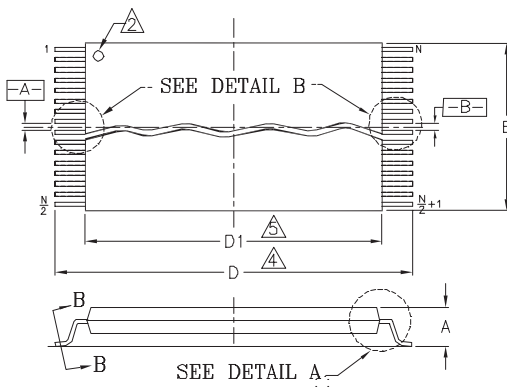

REVERSE PIN OUT (TOP VIEW)

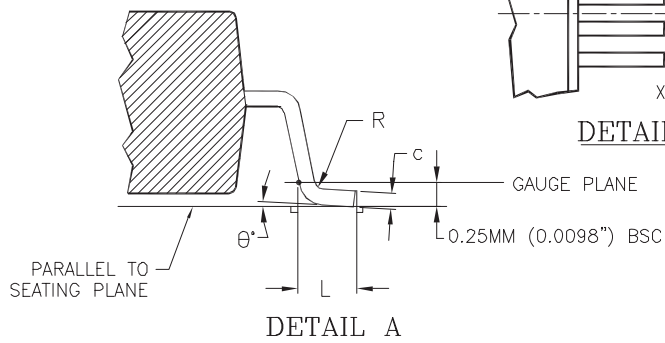
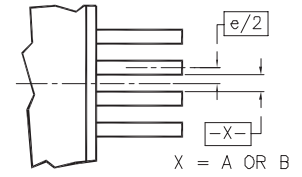
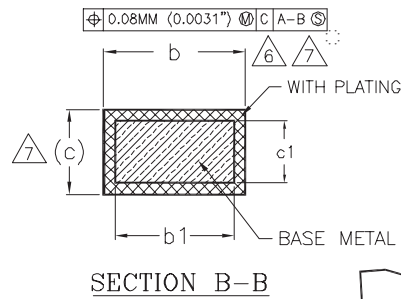
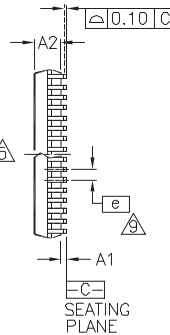
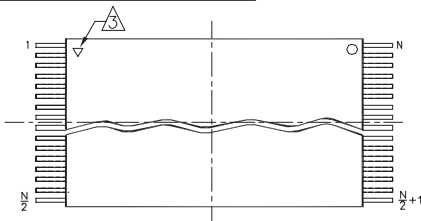

PACKAGE	TS/TSR 56		
JEDEC	MO-142 (B) EC		
SYMBOL	MIN.	NOM.	MAX.
A	---	---	1.20
A1	0.05	---	0.15
A2	0.95	1.00	1.05
b1	0.17	0.20	0.23
b	0.17	0.22	0.27
c1	0.10	---	0.16
c	0.10	---	0.21
D	19.90	20.00	20.20
D1	18.30	18.40	18.50
E	13.90	14.00	14.10
e	0.50 BASIC		
L	0.50	0.60	0.70
∅	0°	3°	5°
R	0.08	---	0.20
N	56		

NOTES:

- 1 CONTROLLING DIMENSIONS ARE IN MILLIMETERS (mm). (DIMENSIONING AND TOLERANCING CONFORMS TO ANSI Y14.5M-1982.)
- 2 PIN 1 IDENTIFIER FOR STANDARD PIN OUT (DIE UP).
- 3 PIN 1 IDENTIFIER FOR REVERSE PIN OUT (DIE DOWN), INK OR LASER MARK.
- 4 TO BE DETERMINED AT THE SEATING PLANE [C]. THE SEATING PLANE IS DEFINED AS THE PLANE OF CONTACT THAT IS MADE WHEN THE PACKAGE LEADS ARE ALLOWED TO REST FREELY ON A FLAT HORIZONTAL SURFACE.
- 5 DIMENSIONS D1 AND E DO NOT INCLUDE MOLD PROTRUSION. ALLOWABLE MOLD PROTRUSION IS 0.15 mm PER SIDE.
- 6 DIMENSION b DOES NOT INCLUDE DAMBAR PROTRUSION. ALLOWABLE DAMBAR PROTRUSION SHALL BE 0.08 mm TOTAL IN EXCESS OF b DIMENSION AT MAX MATERIAL CONDITION. MINIMUM SPACE BETWEEN PROTRUSION AND AN ADJACENT LEAD TO BE 0.07 mm.
- 7 THESE DIMENSIONS APPLY TO THE FLAT SECTION OF THE LEAD BETWEEN 0.10 mm AND 0.25 mm FROM THE LEAD TIP.
- 8 LEAD COPLANARITY SHALL BE WITHIN 0.10 mm AS MEASURED FROM THE SEATING PLANE.
- 9 DIMENSION "e" IS MEASURED AT THE CENTERLINE OF THE LEADS.

316038.10A

PHYSICAL DIMENSIONS

LAA064—64-Ball Fortified Ball Grid Array (FBGA) 13 x 11 mm Package

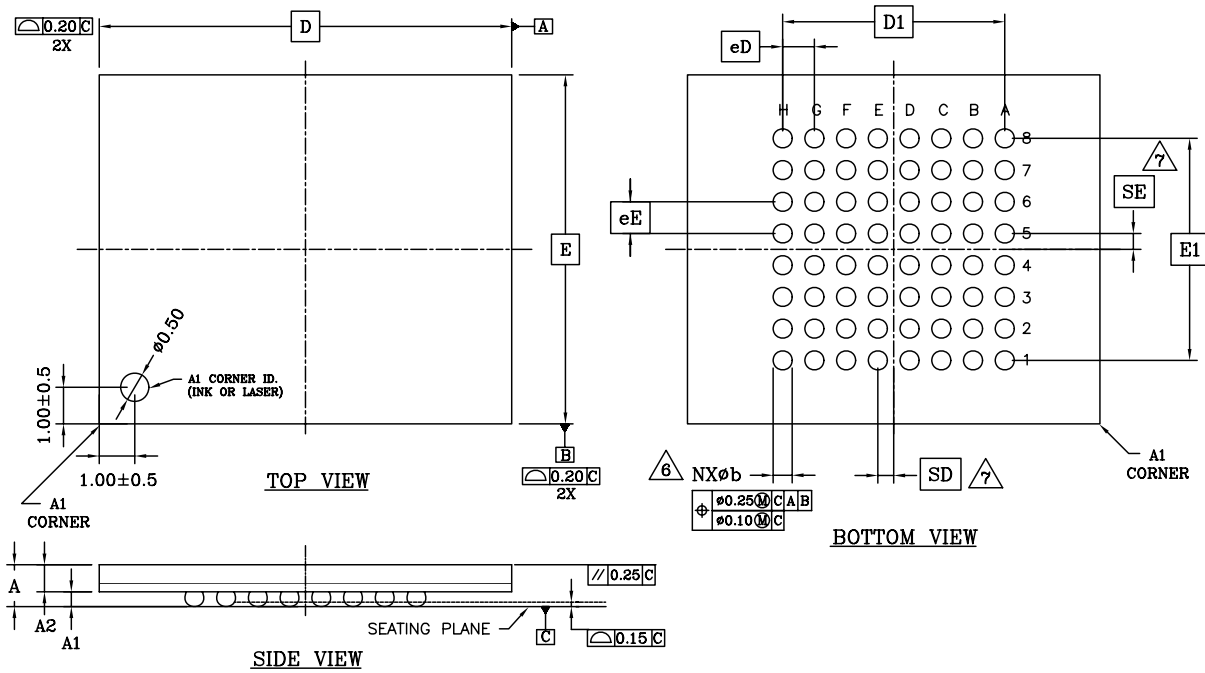

PACKAGE	LAA 064			
JEDEC	N/A			
	13.00x11.00 mm PACKAGE			
SYMBOL	MIN.	NOM.	MAX.	NOTE
A	-	-	1.40	PROFILE HEIGHT
A1	0.40	-	-	STANDOFF
A2	0.60	-	-	BODY THICKNESS
D	13.00 BSC.			BODY SIZE
E	11.00 BSC.			BODY SIZE
D1	7.00 BSC.			MATRIX FOOTPRINT
E1	7.00 BSC.			MATRIX FOOTPRINT
MD	8			MATRIX SIZE D DIRECTION
ME	8			MATRIX SIZE E DIRECTION
N	64			BALL COUNT
φb	0.50	0.60	0.70	BALL DIAMETER
eD	1.00 BSC.			BALL PITCH - D DIRECTION
eE	1.00 BSC.			BALL PITCH - E DIRECTION
SD/SE	0.50 BSC.			SOLDER BALL PLACEMENT
	A1-AB, K1-K8			DEPOPULATED SOLDER BALLS

NOTES:

- DIMENSIONING AND TOLERANCING METHODS PER ASME Y14.5M-1994 .
- ALL DIMENSIONS ARE IN MILLIMETERS .
- BALL POSITION DESIGNATION PER JESD 95-1, SPP-010 (EXCEPT AS NOTED).
- [C] REPRESENTS THE SOLDER BALL GRID PITCH .
- SYMBOL "MD" IS THE BALL MATRIX SIZE IN THE "D" DIRECTION.  
SYMBOL "ME" IS THE BALL COLUMN MATRIX SIZE IN THE "E" DIRECTION.  
N IS THE NUMBER OF POPULATED SOLDER BALL POSITIONS FOR MATRIX SIZE MD X ME.
- DIMENSION "b" IS MEASURED AT THE MAXIMUM BALL DIAMETER IN A PLANE PARALLEL TO DATUM "C".
- SD AND SE ARE MEASURED WITH RESPECT TO DATUMS A AND B AND DEFINE THE POSITION OF THE CENTER SOLDER BALL IN THE OUTER ROW.  
WHEN THERE IS AN ODD NUMBER OF SOLDER BALLS IN THE OUTER ROW, SD OR SE = 0.000.  
WHEN THERE IS AN EVEN NUMBER OF SOLDER BALLS IN THE OUTER ROW, SD OR SE =  $\frac{e}{2}$
- "X" IN THE PACKAGE VARIATIONS DENOTES PART IS UNDER QUALIFICATION.
- "+" INDICATES THE THEORETICAL CENTER OF DEPOPULATED BALLS.

## REVISION SUMMARY

### Revision A (March 19, 2002)

Initial release as abbreviated Advance Information data sheet. This document contains information that was previously released in publication number 25301.

#### Ordering Information

The package marking for the Fortified BGA option has been updated.

#### Physical Dimensions

Added drawing that shows both TS056 and TSR056 specifications.

### Revision B (April 26, 2002)

Expanded data sheet to full specification version.

### Revision C (May 23, 2002)

Changed packaging from 63-ball FBGA to 64-ball Fortified BGA. Changed Block Diagram: Moved  $V_{IO}$  from RY/BY# to Input/Output Buffers. Changed note about WP#/ACC pin to indicate internal pullup to  $V_{CC}$ . Modified Table 4: Sector Group Protection/Unprotection Address Table. Changed 47h Address data from 0004h to 0001h in Table 9.

### Revision D (August 8, 2002)

#### Alternate CE# Controlled Erase and Program Operations

Added  $t_{RH}$  parameter to table.

#### Erase and Program Operations

Added  $t_{BUSY}$  parameter to table.

#### TSOP and BGA PIN Capacitance

Added the FBGA package.

#### Program Suspend/Program Resume Command Sequence

Changed 15  $\mu$ s typical to maximum and added 5  $\mu$ s typical.

#### Erase Suspend/Erase Resume Commands

Changed typical from 20  $\mu$ s to 5  $\mu$ s and added a maximum of 20  $\mu$ s.

#### Special package handling instructions

Modified the special handling wording.

#### DC Characteristics table

Deleted the Iacc specification row.

#### CFI

Changed text in the third paragraph of CFI to read "reading array data."

### Revision D+1 (September 10, 2002)

#### Product Selector Guide

Added Note 2.

#### Ordering Information

Added Note 1.

#### Sector Erase Command Sequence

Deleted statement that describes the outcome of when the Embedded Erase operation is in progress.

### Revision E (December 5, 2002)

#### Product Selector Guide and Read-Only Characteristics

Added a 30 ns option to  $t_{PACC}$  and  $t_{OE}$  standard for the 112R and 120R speed options.

#### Customer Lockable: SecSi Sector NOT Programmed or Protected at the factory.

Added second bullet, SecSi sector-protect verify text and figure 3.

#### SecSi Sector Flash Memory Region, and Enter SecSi Sector/Exit SecSi Sector Command Sequence

Noted that the ACC function and unlock bypass modes are not available when the SecSi sector is enabled.

Byte/Word Program Command Sequence, Sector Erase Command Sequence, and Chip Erase Command Sequence

#### Noted that the SecSi Sector, autoselect, and CFI functions are unavailable when a program or erase operation is in progress.

#### Common Flash Memory Interface (CFI)

Changed CFI website address

#### Figure 6. Program Suspend/Program Resume

Change wait time to 15  $\mu$ s.

#### CMOS Compatible

Added  $I_{LR}$  row to table. Changed  $V_{IH1}$  and  $V_{IH2}$  minimum to 1.9. Removed typos in notes.

#### Hardware Reset, CMOS Tables, Erase and Program Operations, Temporary Sector Unprotect, and Alternate CE# Controlled Erase and Program Operations

Added Note.

### Revision E+1 (February 16, 2003)

#### Distinctive Characteristics

Corrected performance characteristics.

**Product Selector Guide**

Added note 2.

**Ordering Information**

Corrected Valid Combinations table.

Added Note.

**AC Characteristics**

Removed 90, 90R speed option. Added Note

Input values in the  $t_{WHWH1}$  and  $t_{WHWH2}$  parameters in the Erase and Program Options table that were previously TBD. Also, added note 5.

Input values in the  $t_{WHWH1}$  and  $t_{WHWH2}$  parameters in the Alternate CE# Controlled Erase and Program Options table that were previously TBD. Also, added note 5.

**Erase and Programming Performance**

Input values into table that were previously TBD. Added notes 3 and 4.

**Revision E+2 (June 11, 2003)****Ordering Information**

Added 90R speed grade, modified note.

**Erase and Programming Performance**

Modified table, supplied values for Typical.

**Revision F (August 14, 2003)****Global**

Converted document to new Spansion template.

**Ordering Information**

Added note for ordering and marking information related to "N" (factory-protected SecSi Sector) devices.

**Command Definitions**

Corrected Program Erase/Suspend addressing from BA to don't care.

**DC Characteristics table**

Corrected note reference number on  $V_{OL}$  specification.

**Hardware Reset (RESET#)**

Added  $t_{RB}$  specification to table.

**Revision F+1 (February 17, 2004)****Erase Suspend/Erase Resume Commands**

Added note (last paragraph) in reference to erase operation.

**AC Characteristics - Erase and Program Operations, and Alternate CE# Controlled Erase and Program Operations**

Added  $t_{POLL}$  information.

**AC Characteristics - Program Operation Timings, Data# Polling Timings, and Alternate CE# Controlled Write (Erase/Program) Operation Timings**

Updated figures to show  $t_{POLL}$  information.

**Trademarks**

Updated.

**Revision F+2 (August 23, 2004)**

Added Max programming specifications.

Added notation referencing superseding documentation.

**Revision F+3 (December 14, 2005)****Global**

This product has been retired and is not available for designs. For new and current designs, S29GL064A supersedes Am29LV640M H/L and is the factory-recommended migration path. Please refer to the S29GL064A datasheet for specifications and ordering information. Availability of this document is retained for reference and historical purposes only.

**Trademarks**

Copyright © 2002-2005 Advanced Micro Devices, Inc. All rights reserved.

AMD, the AMD logo, and combinations thereof are registered trademarks of Advanced Micro Devices, Inc.

ExpressFlash is a trademark of Advanced Micro Devices, Inc.

Product names used in this publication are for identification purposes only and may be trademarks of their respective companies.