

Finisar

Product Specification

WDM Gigabit GBIC Transceiver with APD Receiver

FTR-1619-XX

PRODUCT FEATURES

- Up to 1.25 Gb/s bi-directional data links
- Extended link budget of **30dB** with APD receiver technology
- Standard GBIC footprint
- Uncooled CWDM-rated DFB laser transmitter
- Class 1 laser safety
- Very low jitter
- Metal enclosure for lower EMI
- Extended voltage range
- Low power dissipation
- Extended operating temperature range: 0°C to 70°C



APPLICATIONS

- Metro Access Rings and Point-to-Point
- Gigabit Ethernet
- SANs

Finisar's FTR-1619-XX WDM GBIC transceivers comply with GBIC Specification Revision 5.4^{1*}. They are compatible with the Gigabit Ethernet standard as specified in IEEE Std 802.3^{2*} and single rate Fibre Channel FC-PH, PH2, PH3^{3*}. The fiber link budget has been enhanced to 30dB with Avalanche Photo Diode (APD) receiver. Additional real time diagnostic functions are also available via the 2-wire serial bus specified for Module Definition "4" GBICs. For details, see Finisar Application Note AN-2030, "Digital Diagnostic Monitoring Interface for SFP Optical Transceivers"⁴. Even with all of these innovative features, the transceiver is still compliant with the mechanical and electrical interfaces defined in the GBIC interoperability standard.

PRODUCT SELECTION**FTR-1619-XX**

Wavelength	XX	Color Code Dot	Wavelength	XX	Color Code Dot
1470 nm	47	Gray	1550 nm	55	Yellow
1490 nm	49	Violet	1570 nm	57	Orange
1510 nm	51	Blue	1590 nm	59	Red
1530 nm	53	Green	1610 nm	61	Brown

I. Pin Out

Pin Name	Pin #	Sequence
RX_LOS	1	2
GND	2	2
GND	3	2
MOD_DEF(0)	4	2
MOD_DEF(1)	5	2
MOD_DEF(2)	6	2
TX_DISABLE	7	2
GND	8	2
GND	9	2
TX_FAULT	10	2
GND	11	1
-RX_DAT	12	1
+RX_DAT	13	1
GND	14	1
V _{CC}	15	2
V _{CC}	16	2
GND	17	1
+TX_DAT	18	1
-TX_DAT	19	1
GND	20	1

Table 1. GBIC to host connector pin assignment

“Sequence” indicates the order in which pins make contact when the device is hot plugged.

Also see “Table 3: Signal Definitions” in the GBIC Specification Revision 5.4.¹

II. Electrical Power Interface

Finisar FTR-1619-XX WDM GBIC modules have a power supply voltage range of 4.75V to 5.25V as described in Table 2.

Electrical Power Interface						
Parameter	Symbol	Min	Typ	Max	Units	Notes/Conditions
Supply Current	I_s		280	350	mA	
Maximum Voltage	V_{max}			6	V	
Surge Current	I_{surge}			400	mA	
Input Voltage	V_{cc}	4.75	5.00	5.25	V	Referenced to GND
Power Supply Rejection	PSR	100			mV	See Note 1. Peak to Peak

Table 2. Electrical power interface

Note 1: Receiver sensitivity is compliant with power supply sinusoidal modulation of 20 Hz to 1.5 MHz up to specified value applied through the recommended power supply filtering network.

III. Low Speed Signals

RX_LOS, TX_DISABLE, and TX_FAULT are TTL signals as described in Table 3. MOD_DEF(1) (SCL) and MOD_DEF(2) (SDA) are open drain CMOS signals (see section VI, “Serial Communication Protocol”). Both MOD_DEF(1) and MOD_DEF(2) must be pulled up to host_Vcc. Note – MOD_DEF(0) is grounded inside the GBIC to indicate the correct mode of operation.

For more detailed information, see sections 5.3.1 – 5.3.8 in the GBIC Specification Rev. 5.4¹.

Low Speed Signals, Electronic Characteristics						
Parameter	Symbol	Min	Max	Units	Notes/Conditions	
GBIC Output LOW	V_{OL}	0	0.5	V	4.7k to 10k pull-up to host_Vcc, measured at host side of connector	
GBIC Output HIGH	V_{OH}	host_Vcc - 0.5	host_Vcc + 0.3	V	4.7k to 10k pull-up to host_Vcc, measured at host side of connector	
GBIC Input LOW	V_{IL}	0	0.8	V	4.7k to 10k pull-up to Vcc, measured at GBIC side of connector	
GBIC Input HIGH	V_{IH}	2	Vcc + 0.3	V	4.7k to 10k pull-up to Vcc, measured at GBIC side of connector	

Table 3. Low speed signals – electronic characteristics

Low Speed Signal Parameters						
Parameter	Symbol	Min	Typ	Max	Units	Notes/Conditions
RX_LOS Assert Level	--	-42	-39		dBm	Measured on Finisar Eval Card
RX_LOS Deassert Level	--		-37	-32	dBm	Measured on Finisar Eval Card
RX_LOS Hysteresis	--		1.0		dB	Measured on Finisar Eval Card
RX_LOS Assert Delay	t_loss_on			100	μsec	From detection of loss of signal to assertion of RX_LOS
RX_LOS Negate Delay	t_loss_off			150	μsec	From detection of presence of signal to negation of RX_LOS
TX_DISABLE Assert Time	t_off			1000	μsec	Rising edge of TX_DISABLE to fall of output signal below 10% of nominal
TX_DISABLE Negate Time	t_on			1000	μsec	Falling edge of TX_DISABLE to rise of output signal above 90% of nominal
TX_DISABLE Reset Time	t_reset	10			μsec	TX_DISABLE HIGH before TX_DISABLE set LOW

Table 4. Low speed signal parameters

IV. High Speed Electrical Interface

All high-speed PECL signals are AC coupled internally.

High Speed Electrical Interface						
Parameter	Symbol	Min	Typ	Max	Units	Notes/Conditions
Data Input Voltage	V _{in}	650		2000	mV	PECL differential peak - peak
Data Output Voltage	V _{out}	370		2000	mV	PECL differential peak - peak
Duty Cycle	--		50		%	
PECL rise/fall	T _r , T _f			150	psec	20% -80% Differential
Bit Error Rate	BER			10 ⁻¹²		PRBS 2 ⁷ - 1 test data pattern
Tx Input Impedance	Z _{in}		75		ohm	Single ended impedance
Rx Output Impedance	Z _{out}		75		ohm	Single ended impedance

Table 5. High speed electrical interface

V. Optical Parameters

Optical Parameters						
Parameter	Symbol	Min	Typ	Max	Units	Notes/Conditions
Transmitter Center Wavelength	λ_c	(x-4)	(x+1)	(x+7)	nm	Over temperature 0 to 70 °C case temperature. See Note 1 below.
Transmitter Center Wavelength	λ_c	(x-4)	(x+1)	(x+6)	nm	Over temperature 0 to 60 °C case temperature. See Note 1 below.
Wavelength Temperature Dependence			0.08		nm/°C	
Spectral Width				1	nm	Full Width, -20dB from peak
Side Mode Suppression Ratio (SMSR)	SMSR	30			dB	
Optical Rise/Fall Time	t_r/t_f			200	ps	Unfiltered, 80% -20%
Transmitter Optical Output Power	P_{out}	+1.0	+3.0	+5.0	dBm	Average power coupled into single mode fiber
Transmitter Extinction Ratio	OMI	9			dB	
Transmitter Eye Opening	--	40			%	IEEE 802.3 and Fibre Channel Eye Mask Margin
Transmitter Jitter				100	ps	Peak to peak, filtered
Optical Return Loss	ORL	14			dB	
Optical Input Wavelength	λ_{in}	1450		1620	nm	
Receiver Jitter Generation				100	ps	See Note 5. Peak to peak
Receiver Optical Input Power (BER < 10 ⁻⁹ w/ PRBS 2 ⁷ -1)	P_{in}	-31	-32	-7	dBm	@ 1.25Gb/s, 70 °C case temperature See Note 4 below.
Receiver Optical Input Power (BER < 10 ⁻¹² w/ PRBS 2 ⁷ -1)	P_{in}	-29	-31	-7	dBm	@ 1.25Gb/s, 70 °C case temperature See Note 4 below.
Dispersion Penalty at 60km				2.0	dB	
Dispersion Penalty at 100km				3.0	dB	

Table 6. Optical parameters

Note 1: The Transmitter Center Wavelength “x” is as specified by the customer. The current available wavelengths are: 1470, 1490, 1510, 1530, 1550, 1570, 1590, and 1610 nm. Please see the “Product Selection” section on page 2.

Note 2: Parameters are specified over temperature and at end of life unless otherwise noted.

Note 3: All parameters are measured on a Finisar GBIC Evaluation Card unless otherwise noted.

Note 4: To convert from dB to kilometers, use 0.3 dB/km. For example, a link budget of 7dB equals 7dB÷0.3dB/km = 23.3km. Add 0.5dB additional loss per connector.

Note 5: Jitter added by receiver.

VI. General Specifications

General						
Parameter	Symbol	Min	Typ	Max	Units	Notes/Conditions
Data Rate	BR	0.125		1.25	Gb/sec	Fibre Channel, IEEE 802.3 compatible
Total System Budget	--	30			dB	@ 1.25 Gb/s, BER < 10 ⁻⁹ w/ PRBS 2 ⁷ -1. See Note 1

Note 1: Total system budget is defined as $P_{out} - P_{in}$ - typical connector losses

Table 7. General specifications

VII. Environmental Specifications

Note that the GBIC Specification requires an ambient temperature range of 0 to +50°C. Finisar FTR-1619-XX GBICs have an extended range from 0°C to +70°C case temperature as specified in Table 8.

Environment						
Parameter	Symbol	Min	Typ	Max	Units	Notes/Conditions
Operating Temp	T _{op}	0		70	°C	Case temperature
Storage Temp	T _{sto}	-10		85	°C	
Eye Safety	--					CDRH and IEC-825 Class 1 Laser Product. See Note 1

Note 1: Complies with FDA performance standards for laser products except for deviations pursuant to Laser Notice No. 50, dated July 26, 2001.

Table 8. Environmental specifications

VIII. Serial Communication Protocol

All Finisar optical GBICs are ‘Module Definition “4”’ and support the 2 wire serial communication protocol outlined in the GBIC Specification ¹. These GBICs use an Atmel AT24C01A 128 byte E²PROM (with an address of 1010000X). For details on interfacing with the E²PROM, see the Atmel data sheet titled “AT24C01A/02/04/08/16 2-Wire Serial CMOS E²PROM.”⁵

All Finisar optical GBICs also incorporate a microcontroller that monitors system parameters such as laser current, laser temperature, and, in the case of 13xx/14xx/15xx/16xx nm parts, transmitted power. For a complete description of how to use Finisar’s extended features, see Finisar’s Application Note AN-2030: “Digital Diagnostic Monitoring Interface for SFP Optical Transceivers.”⁴

CAUTION: The microcontroller implements the Philips I²C protocol including clock stretching. For details, consult the Philips I²C-Bus Specification. Clock stretching allows a fast master to communicate with a slow slave device, and it requires that the host monitor the clock line every time it releases the line high. If a host does not implement clock stretching (drives the bus blind), it must run the clock below 8kHz, so that Finisar’s microcontroller has time to process instructions. If clock stretching is supported, the clock may be run at up to 100kHz.

I ² C Timing Requirements						
Parameter	Symbol	Min	Typ	Max	Units	Notes/Conditions
Atmel I ² C Clock Rate	C _{atmel}	0		100,000	Hz	Bus can be driven blind.
Finisar Microcontroller I ² C Clock Rate	C ₁	10		100,000	Hz	Host must support clock stretching. Microcontroller times out if C < 10Hz.
Finisar Microcontroller I ² C Clock Rate	C ₂	10		8000	Hz	Bus can be driven blind. Microcontroller times out if C < 10Hz.

Table 9. I²C timing requirements

IX. Mechanical Specifications

Finisar WDM GBICs conform to the mechanical specifications outlined in the GBIC Specification Revision 5.4, Section 6¹.

Insertion, Extraction, and Retention Forces						
Parameter	Symbol	Min	Typ	Max	Units	Notes/Conditions
GBIC insertion	F _I	0		20	Newtons	~4.5 lbs
GBIC extraction	F _E	0		15	Newtons	~3.3 lbs
GBIC retention	F _R	130		N/A	Newtons	straight out ~29.3 lbs

Table 10. Insertion, extraction, and retention forces

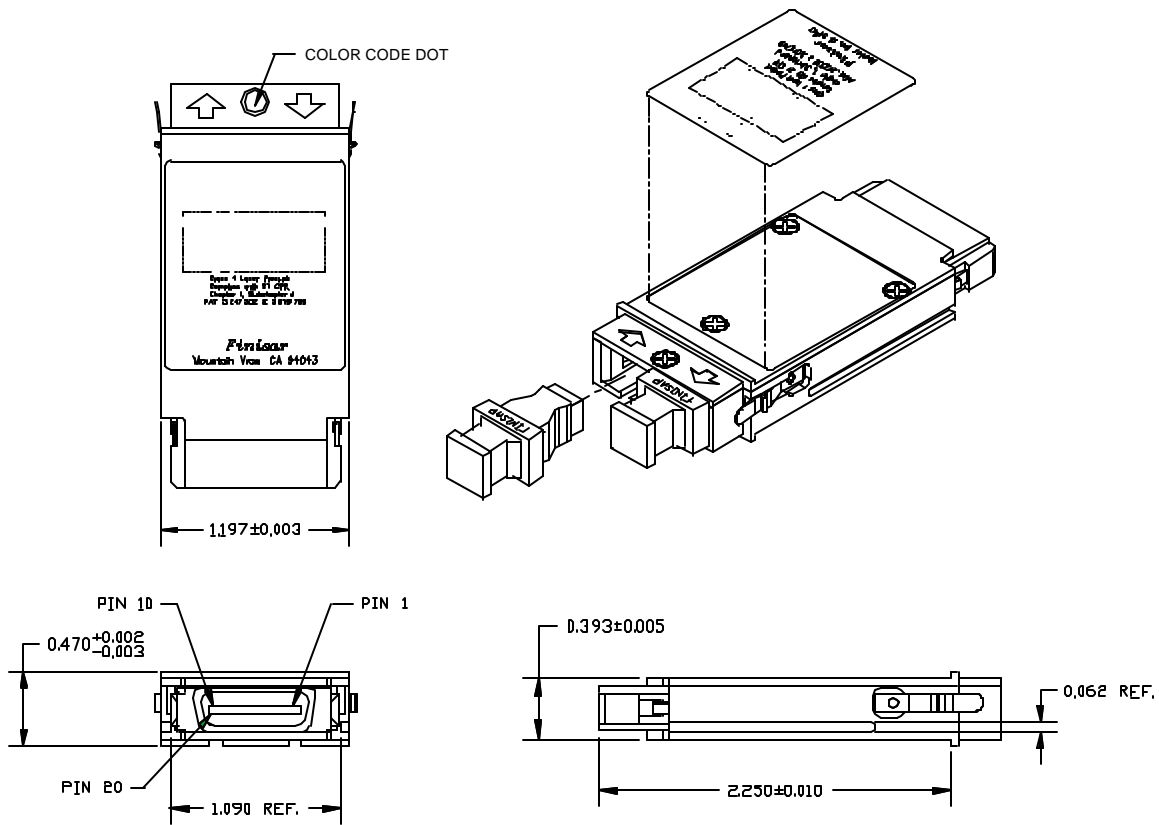

Figure 1. WDM GBIC outline drawing

X. References

1. “Gigabit Interface Converter (GBIC) Revision 5.4”.^(*) Sun Microsystems Computer Company et. al., August 16, 1999. <http://playground.sun.com/pub/OEmod/>
2. IEEE Std 802.3, 2000 Edition, Clause 38. IEEE Standards Department, 2000.
3. “Fibre Channel Physical and Signaling Interface (FC-PH, FC-PH2, FC-PH3)”. American National Standard for Information Systems.
4. “Application Note AN-2030: Digital Diagnostic Monitoring Interface for SFP Optical Transceivers”, Finisar Corporation, April 2002.
5. “AT24C01A/02/04/08/16 2-Wire Serial CMOS E²PROM”. Atmel Corporation. www.Atmel.com

(*) Neither GBIC, FC-PH, nor IEEE802.3 specifies a 14xx/15xx/16xx nm single mode interface. The FTR-1619-XX complies with these specifications except for the following optical parameters: laser wavelength, receiver sensitivity, and transmit output power. See Table 6 for details.

XI. For More Information

Finisar Corporation
1308 Moffett Park Drive
Sunnyvale, CA 94089-1133
Tel. 1-408-548-1000
Fax 1-408-541-6138
sales@finisar.com
www.finisar.com