



SANYO Semiconductors

DATA SHEET

LB1975 — Monolithic Digital IC For Fan Motor 3-phase Brushless Motor Driver

Overview

The LB1975 is a 3-phase brushless motor driver IC suited for use in direct PWM driving of DC fan motors for air conditioners, water heaters, and other similar equipment. Since a shunt regulator circuit is built in, single power supply operation sharing the same power supply for the motor is supported.

Features

- Withstand voltage 46V, output current 2.5A
- Direct PWM drive output
- 3 built-in output top-side diodes
- Built-in current limiter
- Built-in FG output circuit

Specifications

Absolute Maximum Ratings at $T_a = 25^\circ\text{C}$

Parameter	Symbol	Conditions	Ratings	Unit
Supply voltage	V_{CC} max		7	V
	V_M max		46	V
Output current	I_O max		2.5	A
Maximum input current	I_{REG} max	V_{REG} pin	10	mA
Allowable power dissipation	P_d max1	Independent IC	3	W
	P_d max2	With infinite heat sink	20	W
Operating temperature	T_{opr}		-20 to +100	$^\circ\text{C}$
Storage temperature	T_{stg}		-55 to +150	$^\circ\text{C}$

■ Any and all SANYO Semiconductor Co.,Ltd. products described or contained herein are, with regard to "standard application", intended for the use as general electronics equipment (home appliances, AV equipment, communication device, office equipment, industrial equipment etc.). The products mentioned herein shall not be intended for use for any "special application" (medical equipment whose purpose is to sustain life, aerospace instrument, nuclear control device, burning appliances, transportation machine, traffic signal system, safety equipment etc.) that shall require extremely high level of reliability and can directly threaten human lives in case of failure or malfunction of the product or may cause harm to human bodies, nor shall they grant any guarantee thereof. If you should intend to use our products for applications outside the standard applications of our customer who is considering such use and/or outside the scope of our intended standard applications, please consult with us prior to the intended use. If there is no consultation or inquiry before the intended use, our customer shall be solely responsible for the use.

■ Specifications of any and all SANYO Semiconductor Co.,Ltd. products described or contained herein stipulate the performance, characteristics, and functions of the described products in the independent state, and are not guarantees of the performance, characteristics, and functions of the described products as mounted in the customer's products or equipment. To verify symptoms and states that cannot be evaluated in an independent device, the customer should always evaluate and test devices mounted in the customer's products or equipment.

SANYO Semiconductor Co., Ltd.

www.semiconductor-sanyo.com/network

LB1975

Allowable Operating Ranges at $T_a = 25^\circ\text{C}$

Parameter	Symbol	Conditions	Ratings	Unit
Supply voltage range	V_{CC}		4.5 to 6.7	V
	V_M		20 to 42	V
Input current range	I_{REG}	V_{REG} pin	1 to 5	mA
FG pin applied voltage	V_{FG}		0 to V_{CC}	V
FG pin output current	I_{FG}		0 to 10	mA

Electrical Characteristics at $T_a = 25^\circ\text{C}$, $V_{CC} = 5\text{V}$, $V_M = 30\text{V}$

Parameter	Symbol	Conditions	Ratings			Unit
			min	typ	max	
Supply current	I_{CC}		10	14	18	mA
Output Block						
Output saturation voltage	$V_{Osat1(L)}$	$I_O = 1.0\text{A}$, $V_O(\text{sink})$		1.1	1.4	V
	$V_{Osat1(H)}$	$I_O = 1.0\text{A}$, $V_O(\text{source})$		0.9	1.3	V
	V_{Osat1}	$I_O = 1.0\text{A}$, $V_O(\text{sink}) + V_O(\text{source})$		2.0	2.6	V
	$V_{Osat2(L)}$	$I_O = 2.0\text{A}$, $V_O(\text{sink})$		1.4	1.8	V
	$V_{Osat2(H)}$	$I_O = 2.0\text{A}$, $V_O(\text{source})$		1.2	1.7	V
	V_{Osat2}	$I_O = 2.0\text{A}$, $V_O(\text{sink}) + V_O(\text{source})$		2.6	3.4	V
Output leak current	$I_{OLeak(L)}$				100	μA
	$I_{OLeak(H)}$		-100			μA
Upper side diode forward voltage	V_{FH1}	$I_O = 1.0\text{A}$		1.2	1.6	V
	V_{FH2}	$I_O = 2.0\text{A}$		2.1	2.6	V
Hall Amplifier						
Input bias current	I_{HB}		-4	-1		μA
Common-mode input voltage range	V_{ICM}		1.5		$V_{CC}-1.5$	V
Hall input sensitivity	V_{HIN}		60			mVp-p
Hysteresis width	$\Delta V_{IN(HA)}$		23	32	39	mV
Input voltage (low to high)	V_{SLH}		6	16	25	mV
Input voltage (high to low)	V_{SHL}		-25	-16	-6	mV
FG Pin (speed pulse output)						
Output low-level voltage	V_{FGL}	$I_{FG} = 5\text{mA}$			0.5	V
Pull-up resistor value	R_{FG}		7.5	10	12.5	$\text{k}\Omega$
Current Limiter						
Limiter	V_{RF}		0.45	0.50	0.55	V
Thermal Shutdown						
Thermal shutdown operating temperature	TSD	Design target Value (junction temperature)	150	180		$^\circ\text{C}$
Hysteresis width	ΔTSD	Design target Value (junction temperature)		40		$^\circ\text{C}$
Low-Voltage Protection						
Operating voltage	V_{LVSD}		3.5	3.8	4.1	V
Non-operating voltage	$V_{LVSD(OFF)}$			4.3	4.5	V
Hysteresis width	ΔV_{LVSD}		0.4	0.5	0.6	V
PWM Oscillator						
Output high-level voltage	$V_{OH(OSC)}$		2.95	3.10	3.25	V
Output low-level voltage	$V_{OL(OSC)}$		1.38	1.45	1.59	V
Amplitude	V_{OSC}		1.50	1.65	1.71	Vp-p
Oscillator frequency	f_{OSC}	$C = 2200\text{pF}$	19.6	23.0	27.6	kHz
Charge current	I_{CHG}		-110	-94	-83	μA
Discharge resistance	R_{DCHG}		1.6	2.1	2.6	$\text{k}\Omega$
VREG Pin						
Pin voltage	V_{REG}	$I_{REG} = 1.5\text{mA}$	6.6	7.0	7.2	V

Continued on next page.

LB1975

Continued from preceding page.

Parameter	Symbol	Conditions	Ratings			Unit
			min	typ	max	
VCTL Pin						
Input voltage	VCTL1	Output duty 0%	1.1	1.4	1.7	V
	VCTL2	Output duty 100%	3.2	3.5	3.8	V
Input bias current	I _B 1(CTL)	V _{CTL} = 0V	-82			μA
	I _B 2(CTL)	V _{CTL} = 5V			92	μA
VCTL Amplifier						
Reference voltage	V _{CREF}		2.23	2.35	2.46	V
Output voltage	V _{COU} 1	V _{CTL} = 0V	3.90	4.20	4.40	V
	V _{COU} 2	V _{CTL} = 5V	0.60	0.80	1.10	V
Start/Stop Pin						
High-level input voltage range	V _{IH} (S/S)		V _{CC} -1.5		V _{CC}	V
Low-level input voltage range	V _{IL} (S/S)		0		1.5	V
Input open voltage	V _{IO} (S/S)		V _{CC} -0.5		V _{CC}	V
Hysteresis width	ΔV _{IN} (S/S)		0.35	0.50	0.65	V
High-level input current	I _{IH} (S/S)	V(S/S) = V _{CC}	-10	0	+10	μA
Low-level input current	I _{IL} (S/S)	V(S/S) = 0V	-280	-210		μA
Forward/Reverse Pin						
High-level input voltage range	V _{IH} (F/R)		V _{CC} -1.5		V _{CC}	V
Low-level input voltage range	V _{IL} (F/R)		0		1.5	V
Input open voltage	V _{IO} (F/R)		V _{CC} -0.5		V _{CC}	V
Hysteresis width	ΔV _{IN} (F/R)		0.35	0.50	0.65	V
High-level input current	I _{IH} (F/R)	V(F/R) = V _{CC}	-10	0	+10	μA
Low-level input current	I _{IL} (F/R)	V(F/R) = 0V	-280	-210		μA

Package Dimensions

unit : mm (typ)

3147C

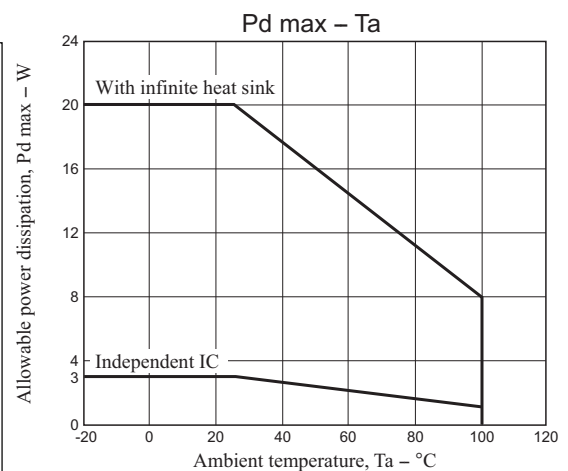
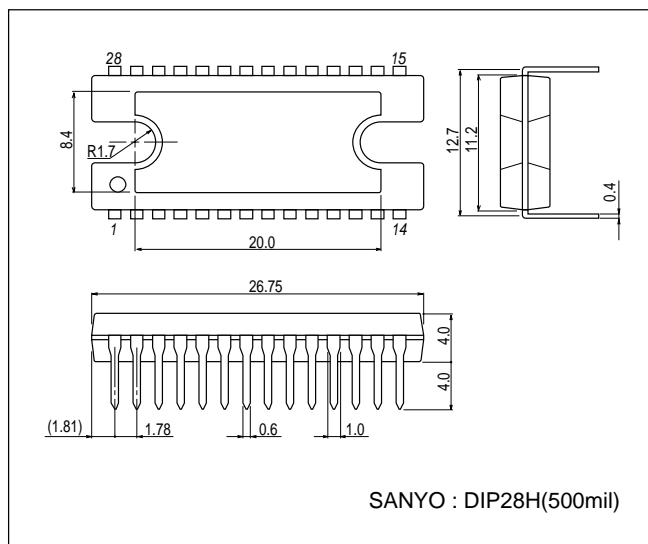

LB1975

Pin Assignment

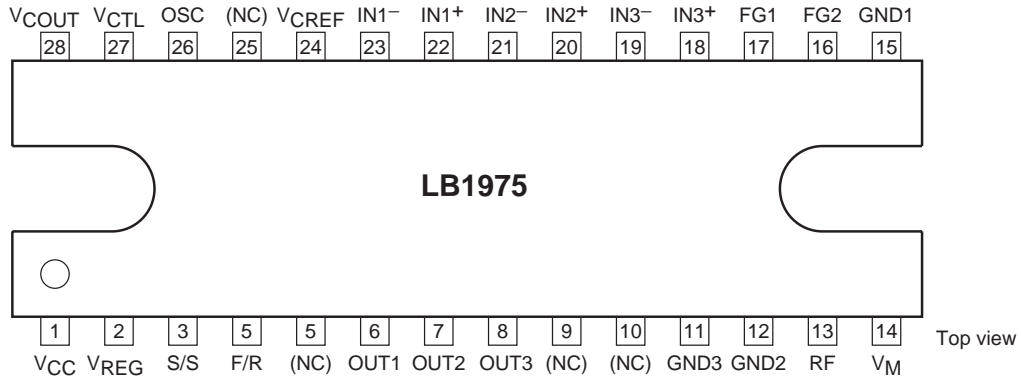

Truth Table

	Input			Forward/reverse control	Output	FG output	
	IN1	IN2	IN3	F/R	Source → Sink	FG1	FG2
1	H	L	H	L	OUT2 → OUT1	L	L
				H	OUT1 → OUT2		
2	H	L	L	L	OUT3 → OUT1	L	H
				H	OUT1 → OUT3		
3	H	H	L	L	OUT3 → OUT2	L	L
				H	OUT2 → OUT3		
4	L	H	L	L	OUT1 → OUT2	H	H
				H	OUT2 → OUT1		
5	L	H	H	L	OUT1 → OUT3	H	L
				H	OUT3 → OUT1		
6	L	L	H	L	OUT2 → OUT3	H	H
				H	OUT3 → OUT2		

F/R

Forward rotation Low 0V to 1.5V
 Reverse rotation High $V_{CC} - 1.5V$ to V_{CC}

FG output

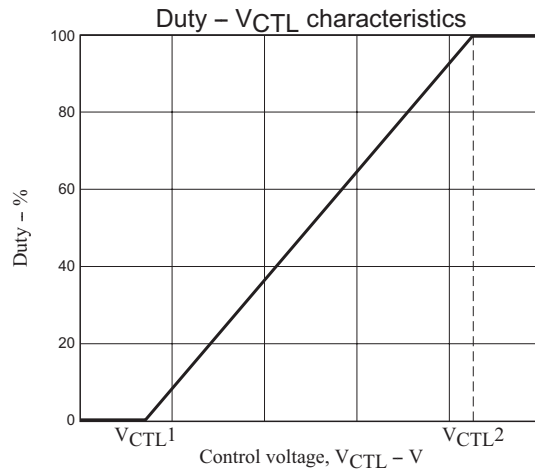
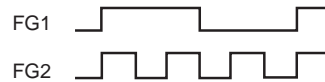

Block Diagram and Peripheral Circuit

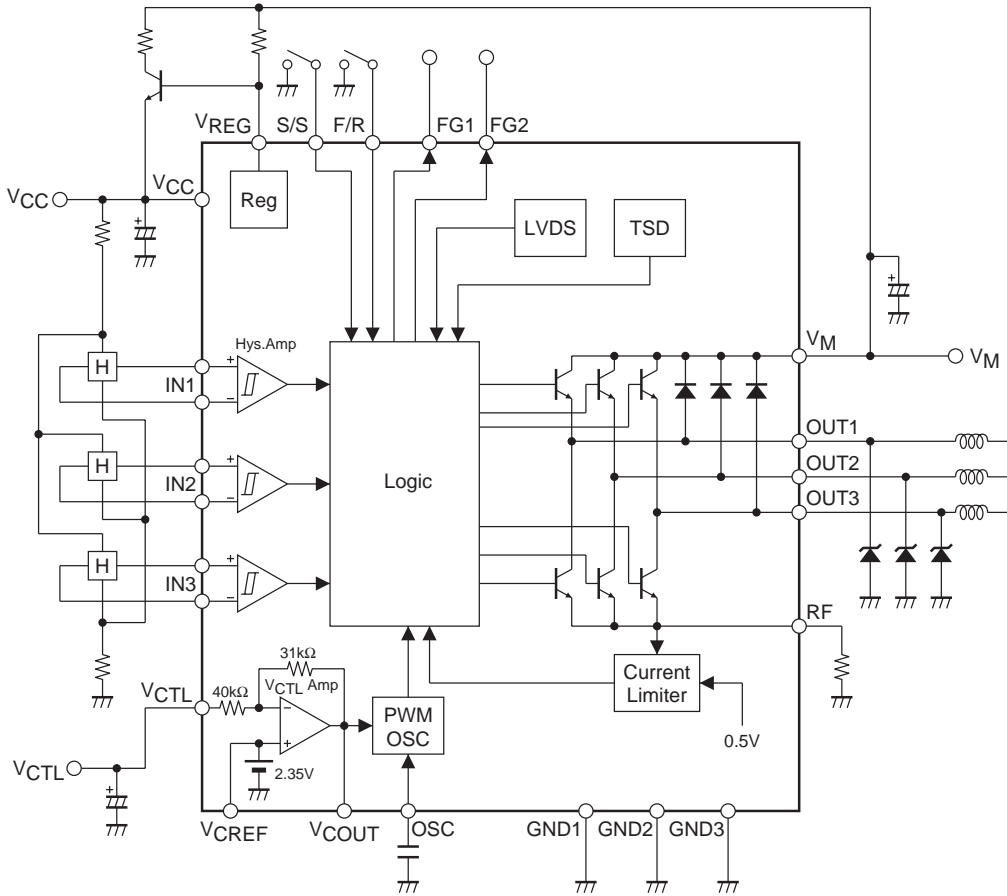

Pin Functions

Pin No.	Pin name	Pin voltage	Function	Equivalent circuit
1	VCC	4.5V to 6.7V	Power supply for blocks other than the output block.	
2	VREG	0.0V to 7.3V	Shunt regulator output pin (7V).	
3	S/S	0.0V to VCC	Start/stop control pin. Low: start High or Open: stop Typical threshold voltage for VCC = 5V: approx. 2.8V (low to high) approx. 2.3V (high to low)	

Continued on next page.

LB1975

Continued from preceding page.

Pin No.	Pin name	Pin voltage	Function	Equivalent circuit
4	F/R	0.0V to V_{CC}	Forward/reverse pin. Low: forward High or Open: reverse Typical threshold voltage for $V_{CC} = 5V$: approx. 2.8V (low to high) approx. 2.3V (high to low)	
6 7 8	OUT1 OUT2 OUT3		Output pin 1. Output pin 2. Output pin 3.	
13	RF	0.0V to V_{CC}	Output current detect pin. Connect resistor R_f between this pin and ground. Output current is limited to value set with V_{RF}/R_f . (Current limiter operation)	
14	V_M		Output block power supply.	
11	GND3		Output block ground.	
15	GND1		Ground for blocks other than the output block.	
12	GND2		Ground for blocks other than the output block.	
17	FG1	0.0V to V_{CC}	Speed pulse output pin 1 with built-in pull-up resistor.	
16	FG2	0.0V to V_{CC}	Speed pulse output pin 2 with built-in pull-up resistor.	
22 23 20 21 18 19	IN1+ IN1- IN2+ IN2- IN3+ IN3-	1.5V to $V_{CC} - 1.5V$	Hall input pin. $IN^+ > IN^-$: High input $IN^+ < IN^-$: Low input	
26	OSC	1.0V to V_{CC}	This pin sets the PWM oscillation frequency. Connect a capacitor between this pin and ground.	

Continued on next page.

LB1975

Continued from preceding page.

Pin No.	Pin name	Pin voltage	Function	Equivalent circuit
27	V _{CTL}	0.0V to 6.7V	Output duty cycle control pin. <ul style="list-style-type: none"> • $V_{CTL} \leq V_{CTL1}$ Duty cycle 0% • $V_{CTL1} < V_{CTL} < V_{CTL2}$ Duty cycle is controlled by V_{CTL} • $V_{CTL} \geq V_{CTL2}$ Duty cycle 100% 	
24	V _{CREF}	0.0V to V _{CC} - 2.0V	V _{CTL} amplifier internal reference voltage pin (2.35V).	
28	V _{COU}	0.7V to V _{CC} - 0.7V	V _{CTL} amplifier output pin.	

IC Description

1. Direct PWM Drive

The LB1975 employs the direct PWM drive principle. Motor rotation speed is controlled by varying the output duty cycle according to an analog voltage input (V_{CTL}). This eliminates the need to alter the motor power supply voltage. Compared to previous ICs using the PAM principle (such as the Sanyo LB1690), this allows simplification of the power supply circuitry. The V_{CTL} input can be directly supplied by a microcontroller, motor speed can, therefore, be controlled directly from the microcontroller.

For PWM, the source-side output transistors are switched on and off so that the ON duty tracks the V_{CTL} input. The output duty cycle can be controlled over the range of 0% to 100% by the V_{CTL} input.

2. PWM Frequency

The PWM oscillator frequency f_{PWM} [Hz] is set by the capacitance C [pF] connected between the OSC pin and GND. The following equation applies:

$$f_{PWM} \approx 1 / (1.97 \times C) \times 10^8$$

Because output transistor on/off switching is subject to a delay, setting the PWM frequency to a very high value will cause the delay to become noticeable. The PWM frequency therefore should normally be kept below 40kHz (typ.), which is achieved with a capacitance C of 1300pF or higher. For reference, the source-side output transistor switching delay time is about 2 μ s for ON and about 4 μ s for OFF.

3. Output Diodes

Because the PWM switching operation is carried out by the source-side output transistors, Schottky barrier diodes must be connected between the OUT pins and GND (OUT1 to OUT3). Use diodes with an average forward current rating in the range of 1.0 to 2.0A, in accordance with the motor type and current limiting requirements.

If no Schottky barrier diodes are connected externally, or if Schottky barrier diodes with high forward voltage (V_F) are used, the internal parasitic diode between OUT and GND becomes active. When this happens, the output logic circuit may malfunction, resulting in feed-through current in the output which can destroy the output transistors. To prevent this possibility, Schottky barrier diodes must be used and dimensioned properly.

The larger the V_F of the externally connected Schottky barrier diodes, or the hotter the IC is, the more likely are the parasitic diodes between OUT and GND to become active and the more likely is malfunction to occur. The V_F of the Schottky barrier diodes must be determined so that output malfunction does not occur also when the IC becomes hot. If malfunction occurs, choose a Schottky barrier diode with lower V_F .

4. Protection circuits

4-1. Low voltage protection circuit

When the V_{CC} voltage falls below a stipulated level (V_{LVSD}), the low voltage protection circuit cuts off the source-side output transistors to prevent V_{CC} related malfunction.

4-2. Thermal shutdown circuit (overheat protection circuit)

When the junction temperature rises above a stipulated value (TSD), the thermal shutdown circuit cuts off the source-side output transistors to prevent IC damage due to overheating. Design the application heat characteristics so that the protection circuit will not be triggered under normal circumstances.

4-3. Current limiter

The current limiter cuts off the source-side output transistors when the output current reaches a preset value (limiter value). This interrupts the source current and thereby limits the output current peak value. By connecting the resistance R_f between the RF pin and ground, the output current can be detected as a voltage. When the RF pin voltage reaches 0.5V (typ.), the current limiter is activated. It performs on/off control of the source-side output transistors, thereby limiting the output current to the value determined by $0.5/R_f$.

5. Hall Input Circuit

The Hall input circuit is a differential amplifier with a hysteresis of 32mV (typ.). The operation DC level must be within the common-mode input voltage range (1.5V to $V_{CC} - 1.5V$). To prevent noise and other adverse influences, the input level should be at least 3 times the hysteresis (120 to 16mVp-p). If noise at the Hall input is a problem, a noise-canceling capacitor (about 0.01 μ F) should be connected across the Hall input IN^+ and IN^- pins.

6. FG Output Circuit

The Hall input signal at $IN1$, $IN2$, and $IN3$ is combined and subject to waveform shaping before being output. The signal at FG1 has the same frequency as the FG1 Hall input, and the signal at FG2 has a frequency that is three times higher.

7. Start/Stop Control Circuit

The start/stop control circuit turns the source-side output transistors OFF (motor stop) when a High signal is input at the S/S pin or when the pin is Open. When a Low signal is input at the S/S pin, the source-side output transistors are turned ON, and the normal operation state is established (motor start).

8. Forward/Reverse Switching

The LB1975 is designed under the assumption that forward/reverse switching is not carried out while the motor is running. If switching is carried out while the motor is running, reverse torque braking occurs, leading to a high current flow. If the current limiter is triggered, the source-side output transistors are switched off, and the sink-side output transistors go into the short brake condition. However, because the current limiter of this IC cannot control the current flowing in the sink-side output transistors, these may be destroyed by the short brake current. Therefore F/R switching while the motor is running is permissible only if the output current (I_O) is limited to a maximum of 2.5A using the motor coil resistance or other suitable means.

F/R switching should be carried out only while a High signal is input to the S/S pin or the pin is Open (stop condition), or while the VCTL pin conforms to the following condition: $V_{CTL} \leq V_{CTL1}$ (duty cycle 0%). In any other condition, F/R switching will result in feed-through current. The F/R pin should therefore be fixed to Low (forward) or High or Open (reverse) during use.

9. VCC, VM Power Supplies

When the power supply voltage (V_{CC} , V_M) rises very quickly when a power is first applied, a feed-through current may occur at the output. If the current remains below about 0.2A to 0.3A, it does not pose a problem, but such a possibility should still be prevented by slowing down the voltage rise at power-on. Especially if the F/R pin is set to High or Open (reverse), a quick rise in V_{CC} is likely to cause feed-through current. This should be prevented by ensuring that $\Delta V_{CC} / \Delta t = 0.2V/\mu s$ or less. Feed-through current can also be prevented by first switching on V_{CC} and then V_M during power-on.

The sequence at power-down should be as follows. Provide a stop input to the S/S pin or a duty ratio 0% input to the VCTL pin. When the motor has come to a full stop, switch off V_M and then V_{CC} . If power is switched off while the motor is still rotating or a current is flowing in the motor coil (including motor restraint or inertia rotation), a counter electromotive current or kickback current may flow on the V_M side, depending on the motor type and power-off procedure. If this current cannot be absorbed by the V_M power supply or a capacitor, V_M voltage may rise and exceed the absolute maximum V_M rating for the IC. Ensure that this does not happen through proper design of the V_M power supply or through use of a capacitor.

Because the LB1975 incorporates a shunt regulator, it can be used on a single power supply. In this case, supply V_{CC} (6.3V typ.) to the VREG pin via an external NPN transistor and resistor. When not using the regulator, leave the VREG pin open.

10. Power Supply Stabilizing Capacitors

If the V_{CC} line fluctuates drastically, the low-voltage protection circuit may be activated by mistake, or other malfunctions may occur. The V_{CC} line must therefore be stabilized by connecting a capacitor of at least several μF between V_{CC} and GND. Because a large switching current flows in the V_M line, wiring inductance and other factors can lead to V_M voltage fluctuations. As the GND line also fluctuates, the V_M line must be stabilized by connecting a capacitor of at least several μF between V_M and GND, to prevent exceeding V_M max or other problems. Especially when long wiring runs (V_M , V_{CC} , GND) are used, sufficient capacitance should be provided to ensure power supply stability.

11. VCREf Pin, VCOuT Pin

These pins are always used in the Open condition. If chattering occurs in the PWM switching output, connect a capacitor (about 0.1 μF) between VCREf and ground or between VCOuT and GND.

12. IC Heat Dissipation Fins

A heat sink may be mounted to the heat dissipation fins of this IC, but it may not be connected to GND. The sink should be electrically open.

13. Sample calculation for internal power dissipation (approximate)

The calculation assumes the following parameters:

$$V_{CC} = 5V$$

$$V_M = 30V$$

Source-side output transistor ON duty cycle 80% (PWM control)

Output current $I_O = 1A$ (RF pin average current)

(1) I_{CC} power dissipation P1

$$P1 = V_{CC} \times I_{CC} = 5V \times 14mA = 0.07W$$

(2) Output drive current power dissipation P2

$$P2 = V_M \times 11mA = 30V \times 11mA = 0.33W$$

(3) Source-side output transistor power dissipation P3

$$P3 = V_O(\text{source}) \times I_O \times \text{Duty}(\text{on}) = 0.9V \times 1A \times 0.8 = 0.72W$$

(4) Sink-side output transistor power dissipation P4

$$P4 = V_O(\text{sink}) \times I_O = 1.1V \times 1A = 1.10W$$

(5) Total internal power dissipation P

$$P = P1 + P2 + P3 + P4 = 2.22W$$

14. IC temperature Rise Measurement

Because the chip temperature of the IC cannot be measured directly, measurement according to one of the following procedures should always be carried out.

14-1. Thermocouple measurement

A thermocouple element is mounted to the IC heat dissipation fin. This measurement method is easy to implement, but it will be subject to measurement errors if the temperature is not stable.

14-2. Measurement using internal diode characteristics of IC

This is the recommended measurement method. It makes use of the parasitic diode incorporated in the IC between FG1 and GND. Set FG1 to High and measure the voltage V_F of the parasitic diode to calculate the temperature. (Sanyo data: for $I_F = -1mA$, V_F temperature characteristics are about $-2mV/^\circ C$)

15. NC Pins

Because NC pins are electrically open, they may be used for wiring purpose etc.

- SANYO Semiconductor Co.,Ltd. assumes no responsibility for equipment failures that result from using products at values that exceed, even momentarily, rated values (such as maximum ratings, operating condition ranges, or other parameters) listed in products specifications of any and all SANYO Semiconductor Co.,Ltd. products described or contained herein.
- SANYO Semiconductor Co.,Ltd. strives to supply high-quality high-reliability products, however, any and all semiconductor products fail or malfunction with some probability. It is possible that these probabilistic failures or malfunction could give rise to accidents or events that could endanger human lives, trouble that could give rise to smoke or fire, or accidents that could cause damage to other property. When designing equipment, adopt safety measures so that these kinds of accidents or events cannot occur. Such measures include but are not limited to protective circuits and error prevention circuits for safe design, redundant design, and structural design.
- In the event that any or all SANYO Semiconductor Co.,Ltd. products described or contained herein are controlled under any of applicable local export control laws and regulations, such products may require the export license from the authorities concerned in accordance with the above law.
- No part of this publication may be reproduced or transmitted in any form or by any means, electronic or mechanical, including photocopying and recording, or any information storage or retrieval system, or otherwise, without the prior written consent of SANYO Semiconductor Co.,Ltd.
- Any and all information described or contained herein are subject to change without notice due to product/technology improvement, etc. When designing equipment, refer to the "Delivery Specification" for the SANYO Semiconductor Co.,Ltd. product that you intend to use.
- Information (including circuit diagrams and circuit parameters) herein is for example only; it is not guaranteed for volume production.
- Upon using the technical information or products described herein, neither warranty nor license shall be granted with regard to intellectual property rights or any other rights of SANYO Semiconductor Co.,Ltd. or any third party. SANYO Semiconductor Co.,Ltd. shall not be liable for any claim or suits with regard to a third party's intellectual property rights which has resulted from the use of the technical information and products mentioned above.

This catalog provides information as of December, 2008. Specifications and information herein are subject to change without notice.