



LB1668, 1668M, LB1667, 1667M

Two-Phase Unipolar Drive Brushless Motor Drivers

Preliminary

Overview

The LB1668 Series are 2-phase unipolar drive brushless motor drivers that feature a wide usable voltage range and a minimal number of required external components. They also support the formation of motor lock protection and automatic recovery circuits.

Functions and Features

- Output protection Zener diodes with variable breakdown voltages
 - When the Z1 and Z2 pins are open: $V_{OLM} = 57\text{ V}$
 - When the Z1 and Z2 pins are shorted: $V_{OLM} = 32\text{ V}$
 - An external Zener diode can be connected between Z1 and V_{CC} .
- Can support both 12-V and 24-V power supplies by changing an external resistor.
- Hall elements can be connected directly.
- 1.5-A output current output transistors built in
- Built-in rotation detection function that outputs low when driven and high when stopped (LB1668/M)
- FG signal function that sets FG high when IN- is low, and sets FG low when IN- is high (LB1667/M)
- Motor lock protection and automatic recovery functions built in
- Thermal shutdown function

Specifications

Absolute Maximum Ratings at $T_a = 25^\circ\text{C}$

Parameter	Symbol	Conditions	Ratings	Unit
Maximum input current	$I_{CC\text{ max}}$	$t \leq 20\text{ ms}$	200	mA
Output voltage	V_{OUT}		Internal	V
Output current	I_{OUT}		1.5	A
Output minus current	I_{OM}		-50	mA
RD/FG influx current	I_{RD}/I_{FG}		10	mA
RD/FG voltage	V_{RD}/V_{FG}		30	V
Allowable power dissipation	$P_d\text{ max}$	LB1667M, 1668M: Mounted on a printed circuit board ($20 \times 15 \times 1.5\text{ mm}^3$, glass epoxy)	0.8	W
		LB1667, 1668	1.1	W
Operating temperature	T_{opr}		-30 to +80	$^\circ\text{C}$
Storage temperature	T_{stg}		-55 to +150	$^\circ\text{C}$

Package Dimensions

unit: mm

3098B-DIP10S

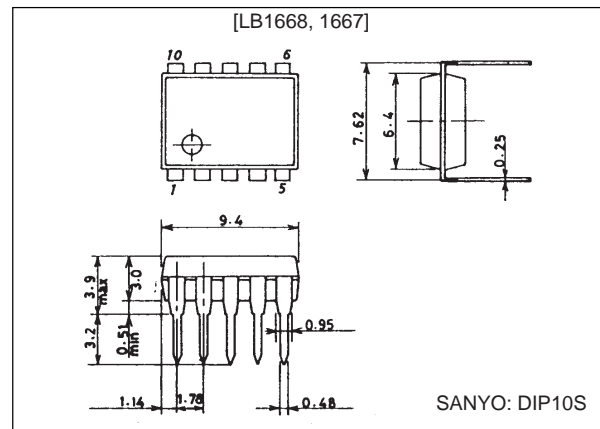

unit: mm

3111-MFP14S

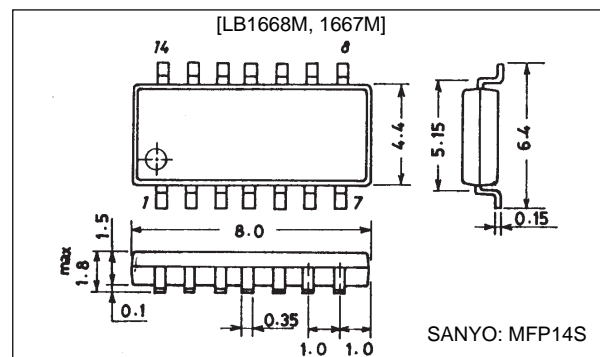

*: These specifications are subject to change for improvement without notice.

LB1668, LB1668M, LB1667, LB1667M

Allowable Operating Ranges at Ta = 25°C

Parameter	Symbol	Conditions	Ratings	Unit
Input current range	I_{CC}		6.0 to 50	mA
Common-mode input voltage range	V_{ICM}		0 to $V_{IN} - 1.5$	V

Electrical Characteristics at Ta = 25°C, $I_{CC} = 10$ mA

Parameter	Symbol	Conditions	Ratings			Unit
			min	typ	max	
Output limit voltage	V_{OLM1}	Z1, Z2 open	54	57	60	V
	V_{OLM2}	Z1, Z2 short	31	33	35	V
Output saturation voltage	V_{osat1}	$I_O = 0.5$ A		0.95	1.2	V
	V_{osat2}	$I_O = 1.0$ A		1.15	1.5	V
	V_{osat3}	$I_O = 1.5$ A		1.4	2.0	V
V_{IN} voltage	V_{IN}	$I_{CC} = 7.0$ mA	6.4	6.7	7.0	V
Amplifier input offset voltage	V_{OFF}		-7.0	0	+7.0	mV
Amplifier input bias current	I_{BA}		-250			nA
RD/FG output saturation voltage	$V_{RDSat}/V_{FG sat}$	$I_{RD}/I_{FG} = 5$ mA		0.1	0.3	V
C outflow current	I_{C1}		2.1	3.0	3.9	μ A
C discharge current	I_{C2}		0.31	0.44	0.59	μ A
Comparator input threshold voltage	V_{TH1}		0.77	$0.8V_{IN}$	0.83	V
	V_{TH2}		0.42	$0.45V_{IN}$	0.48	V
Thermal shutdown current operating temperature	TSD	Design target value		180		°C
Thermal shutdown circuit hysteresis	ΔTSD	Design target value		40		°C

Block Diagram and Application Circuit

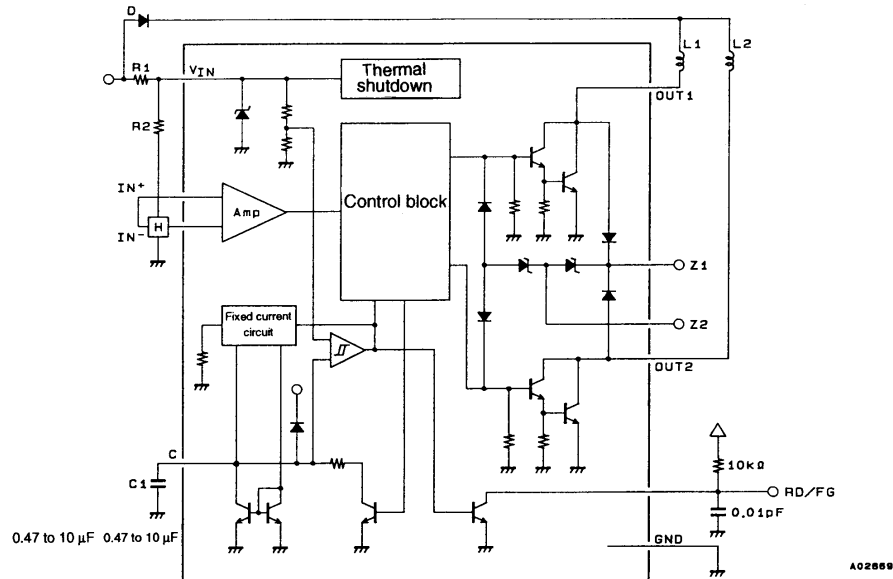

Truth Table (LB1667, LB1667M)

IN+	IN-	C	OUT1	OUT2	FG
H	L	L	H	L	H
L	H	L	L	H	L
H	L	H	H	H	H
L	H	H	H	H	H

Pin Assignments

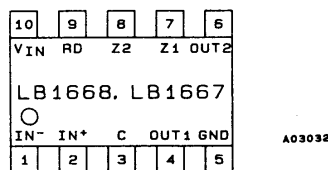

Truth Table (LB1668, LB1668M)

IN+	IN-	C	OUT1	OUT2	RD
H	L	L	H	L	L
L	H	L	L	H	L
H	L	H	H	H	H
L	H	H	H	H	H

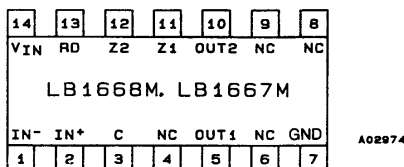

LB1668M Application Circuits

- 12-V power supply type

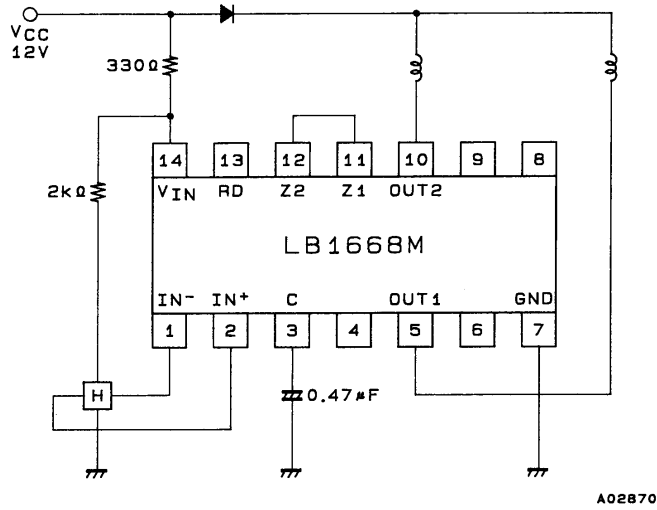

- 24-V power supply type

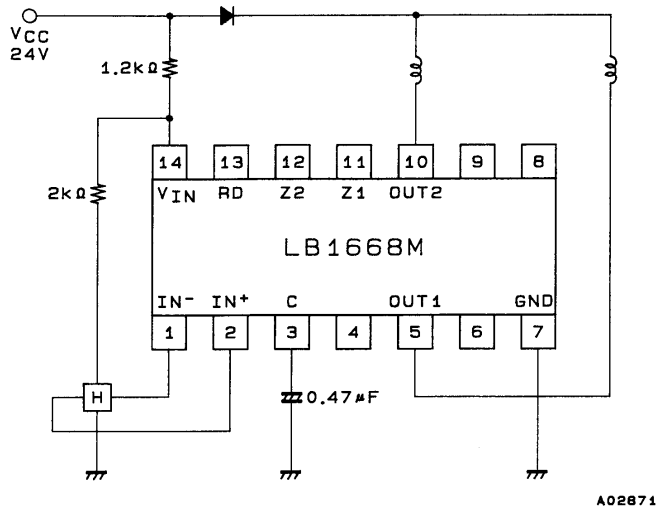

- Circuit for use when large output currents are required and heat dissipation is high.

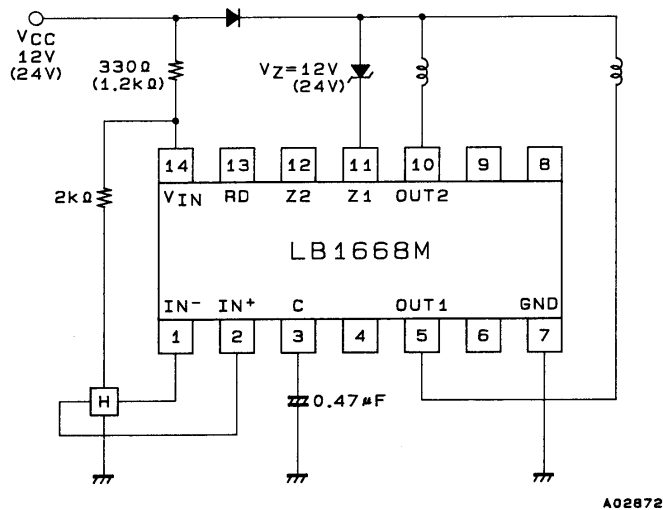

LB1667M Application Circuits

- 12-V power supply type

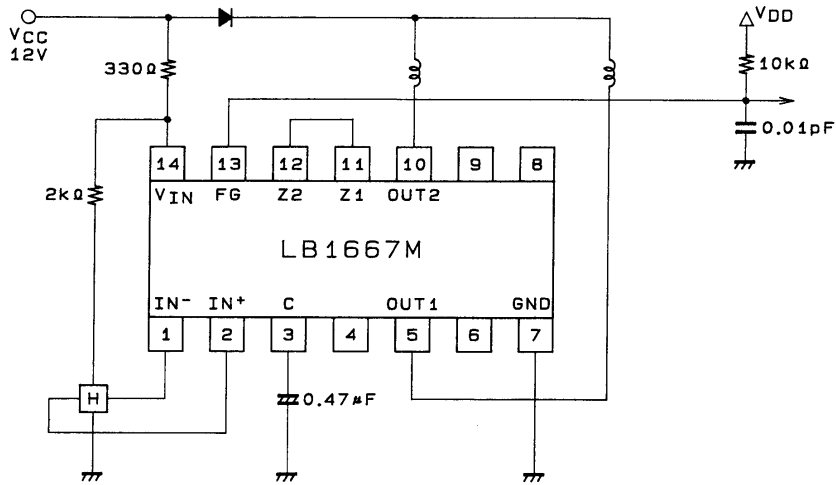

A02873

- 24-V power supply type

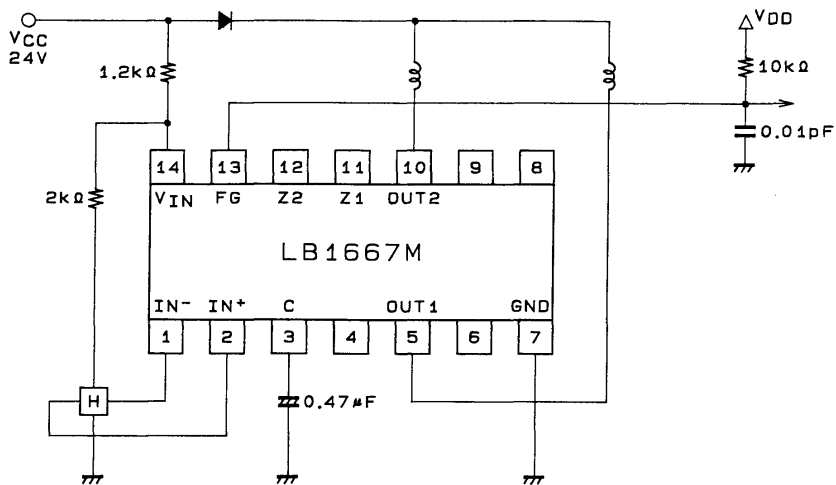

A02874

- Circuit for use when large output currents are required and heat dissipation is high.

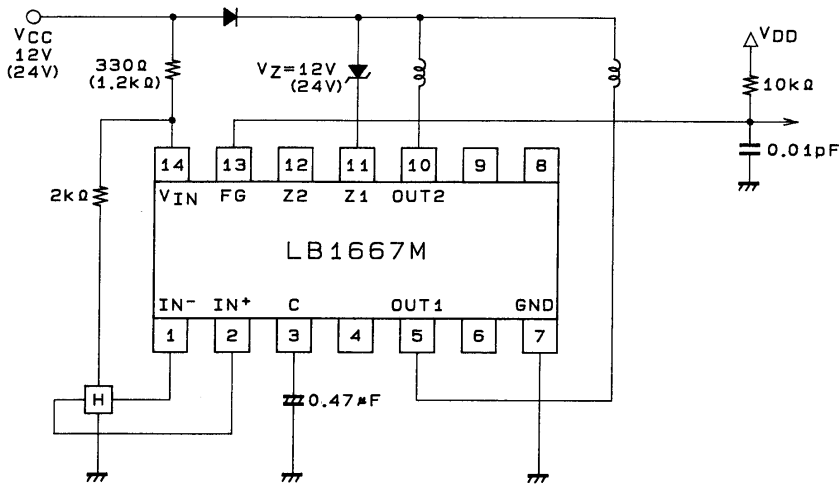

A02875

Design Documentation (See the application circuit diagrams)

1. Power-supply voltage (V_{IN} pin)

The resistor R1 (when $V_{CC} = 12\text{ V}$ $R1 = 330\ \Omega$, and when $V_{CC} = 24\text{ V}$ $R1 =$ about $1.2\text{ k}\Omega$) is inserted between V_{IN} and the power supply V_{CC} pin. When the I_{CC} current is set in the range 6 to 50 mA, the V_{IN} pin will be regulated to be 6.7 V. Not only does this provide stability with respect to power-supply voltage variations and motor kickback, but it also provides adequate strength to withstand surges.

2. Output transistors (OUT1 and OUT2 pins)

A Zener diodes with the following characteristics is inserted between the collector and base of each output transistor to absorb kickback voltages at 57 V (typical) and provide output protection.

Sustained output voltage : $V_O = 65\text{ V}$ minimum (design guarantee)

Output current : $I_O = 1.5\text{ A}$ maximum

Output saturation voltage : $V_O\text{ sat} = 1.25\text{ V}/1.0\text{ A}$ (typical)

Safe operating range : $I_O = 1.0\text{ A}$, $V_{OLM} = 57\text{ V}$, $t = 200\ \mu\text{s}$

3. Output circuit kickback voltage protection (Z1 and Z2 pins)

These ICs support output protection that minimizes kickback noise by changing the kickback absorption voltage and absorption method according to the output current and power-supply voltage used.

— When the Z1 and Z2 pins are shorted

The output protection voltage will be 32 V (typical) using a $V_{CC} = 12\text{ V}$ power supply.

— When the Z1 and Z2 pins are open

The output protection voltage will be 57 V (typical) using a $V_{CC} = 24\text{ V}$ power supply.

— With a Zener diode inserted between Z1 and V_{CC} or between Z1 and ground

This technique handles 120 mm H speed applications which require large output currents and involve large amounts of heat generated in the IC by dissipating the motor coil switching loss in external Zener diodes.

4. Output protection when the motor is lock (C, RD, and FG pins)

This circuit detects motor stopping due to, for example, overloading, and cuts the coil current. It also automatically recovers drive and motor turning from the output stopped state when the load returns to an appropriate level. The lock detection time is set with the value of an external capacitor.

When $C = 0.47\ \mu\text{F}$

Lock detection time: about 1 second

Lock protection time (output on): about 0.5 second

(output off): about 3 seconds

The RD pin (LB1668) is an open collector output and outputs a low level during drive and a high level when stopped.

The FG pin (LB1667) is an open collector output and is switched between high and low by the drive phase. It goes to the high level when the motor is stopped.

5. Thermal shutdown

This circuit turns the output off in response to coil shorting or IC overheating.

6. In applications that use an external transistor to turn the cooling fan power on and off, connect a capacitor of about 0.47 to 10 μF between the fan power supply V_{CC} and ground to provide a regenerative route for the fan motor coil current.

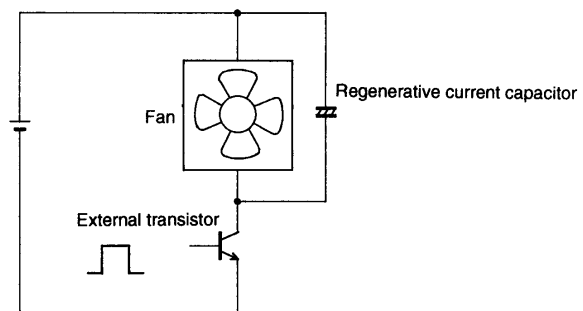

A02975

Automatic Recovery Circuit C-Pin Voltage

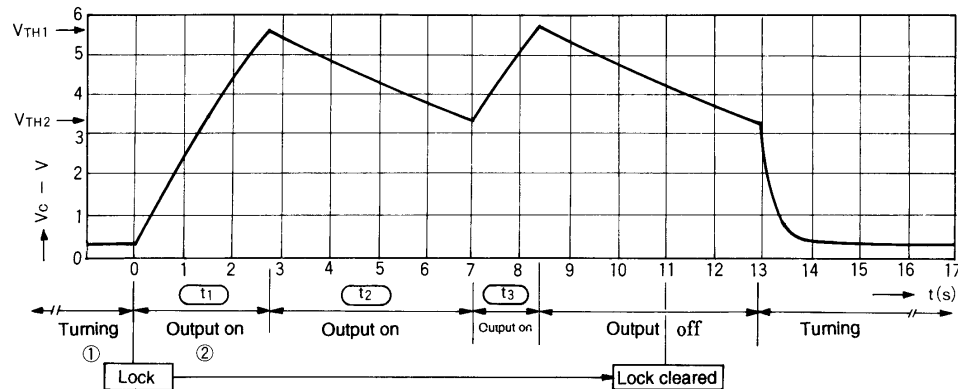

1. While the blades are turning, the capacitor is charged with a current of about $3 \mu\text{A}$ (typical), and C is discharged by pulses that correspond to the motor speed.
2. When the blades lock, the capacitor is no longer discharged, and the voltage across the capacitor increases. The output is turned off when that voltage reaches $0.8 \times V_{IN}$.
3. When the output is turned off, the capacitor is discharged at about $0.44 \mu\text{A}$ (typical). When the capacitor voltage falls under V_{TH2} , if the lock state is not yet cleared the capacitor continues discharging until V_{TH1} . (Note that the output is turned on at this time.) These operations, i.e. items 2. and 3., are repeated with a ton:toff ratio of about 1:6 to protect the motor.
4. If the lock is cleared at the point the capacitor voltage reaches V_{TH2} , motor rotation is started by turning the output on.

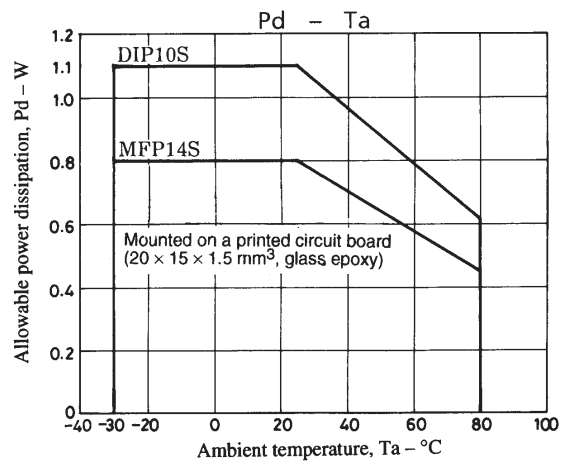
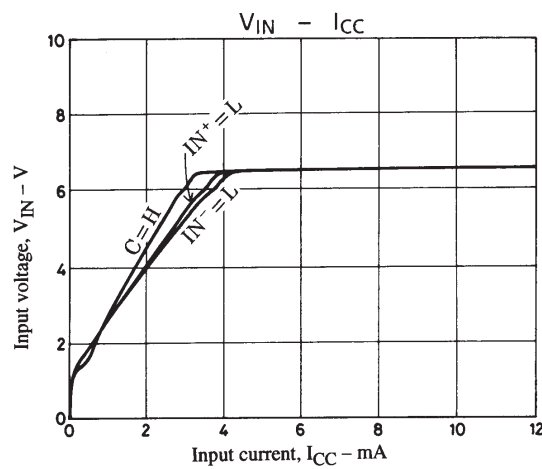
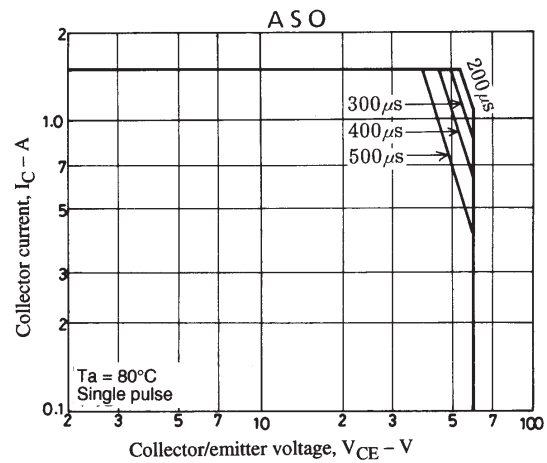
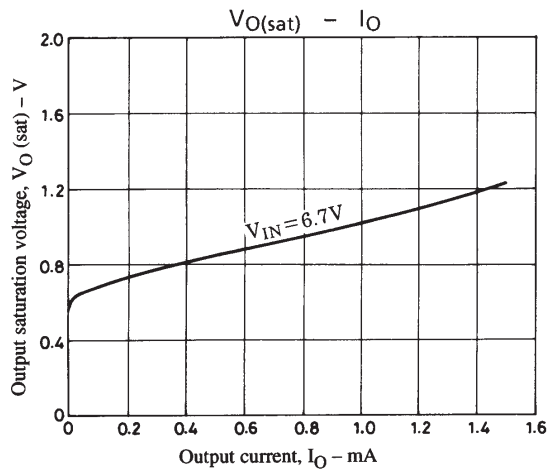

- No products described or contained herein are intended for use in surgical implants, life-support systems, aerospace equipment, nuclear power control systems, vehicles, disaster/crime-prevention equipment and the like, the failure of which may directly or indirectly cause injury, death or property loss.
- Anyone purchasing any products described or contained herein for an above-mentioned use shall:
 - ① Accept full responsibility and indemnify and defend SANYO ELECTRIC CO., LTD., its affiliates, subsidiaries and distributors and all their officers and employees, jointly and severally, against any and all claims and litigation and all damages, cost and expenses associated with such use:
 - ② Not impose any responsibility for any fault or negligence which may be cited in any such claim or litigation on SANYO ELECTRIC CO., LTD., its affiliates, subsidiaries and distributors or any of their officers and employees jointly or severally.
- Information (including circuit diagrams and circuit parameters) herein is for example only; it is not guaranteed for volume production. SANYO believes information herein is accurate and reliable, but no guarantees are made or implied regarding its use or any infringements of intellectual property rights or other rights of third parties.

This catalog provides information as of January, 1997. Specifications and information herein are subject to change without notice.