

# Linear Single Cell Li-Ion Battery Charger IC with Dual Input Supply

## General Description

The RT9502 is a fully integrated low cost single-cell Li-Ion battery charger IC ideal for portable applications. The RT9502 is capable of being powered up from AC adapter and USB (Universal Serial Bus) port inputs. The RT9502 can automatically detect and select the AC adapter and the USB port as the power source for the charger. The RT9502 enters sleep mode when both supplies are removed.

The RT9502 optimizes the charging task by using a control algorithm including precondition mode, fast charge mode and constant voltage mode. The charging task is terminated as the charge current drops below the preset threshold. The USB charge current can be selected from preset ratings of 100mA and 500mA, while the AC adapter charge current can be programmed up to 1A with an external resistor. The internal thermal feedback circuitry regulates the die temperature to optimize the charge rate for all ambient temperatures.

The RT9502 features 18V and 7V maximum rating voltages for AC adapter and USB port inputs respectively. The other features are under voltage protection, over voltage protection for AC adapter supply and battery temperature monitoring.

## Ordering Information

- RT9502 □ □
- Package Type  
QW : WDFN-10L 3x3 (W-Type)
  - Lead Plating System  
P : Pb Free  
G : Green (Halogen Free and Pb Free)

Note :

Richtek products are :

- ▶ RoHS compliant and compatible with the current requirements of IPC/JEDEC J-STD-020.
- ▶ Suitable for use in SnPb or Pb-free soldering processes.

## Features

- Automatic Input Supplies Selection
- 18V Maximum Rating for AC Adapter
- Integrated Selectable 100mA and 500mA USB Charge Current
- Internal Integrated P-MOSFETs
- AC Adapter Power Good Status Indicator
- Charge Status Indicator
- Under Voltage Protection
- Over Voltage Protection
- Automatic Recharge Feature
- Battery Temperature Monitoring
- Small 10-Lead WDFN Package
- Thermal Feedback Optimizing Charge Rate
- RoHS Compliant and 100% Lead (Pb)-Free

## Applications

- Digital Cameras
- Cellular Phones
- Personal Digital Assistants (PDAs)
- MP3 Players
- Hand Held PCs

## Pin Configurations

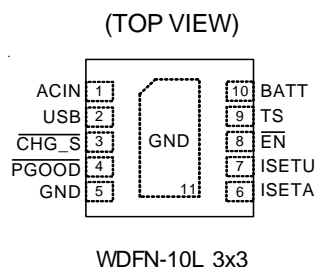

## Marking Information

For marking information, contact our sales representative directly or through a Richtek distributor located in your area.

## Typical Application Circuit

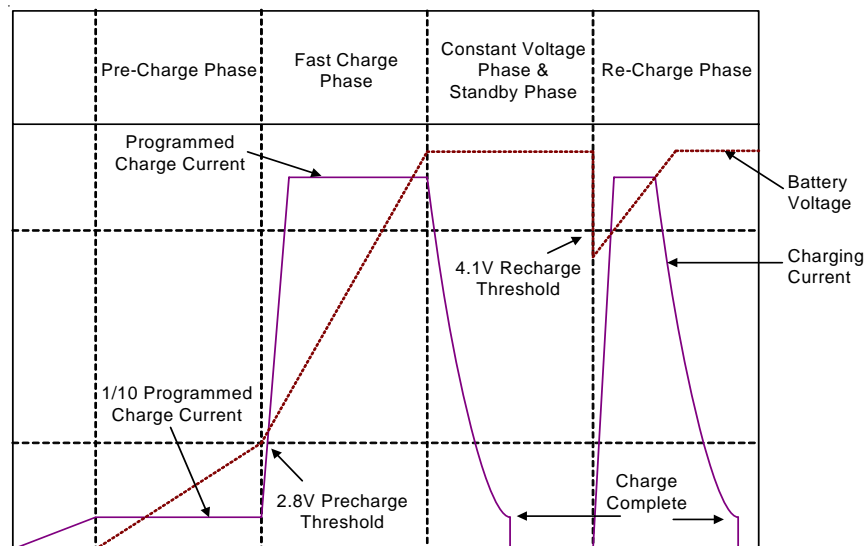
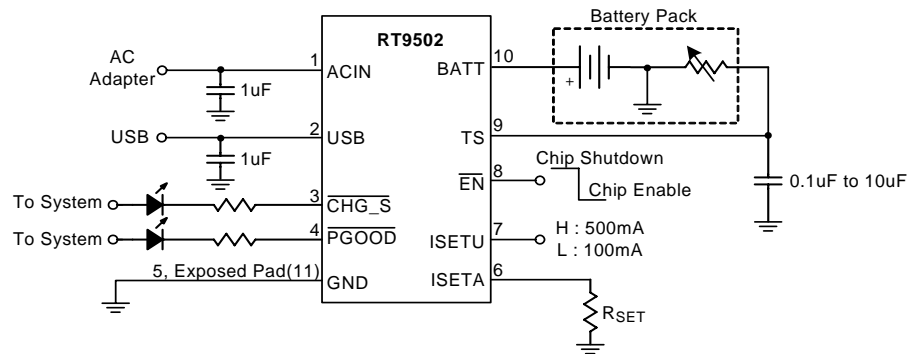

## Functional Pin Description

Pin No.	Pin Name	Pin Function
1	ACIN	AC Adaptor Charge Input Supply.
2	USB	USB Charge Input Supply.
3	$\overline{\text{CHG\_S}}$	Charge Status Indicator Output (open drain).
4	$\overline{\text{PGOOD}}$	Power Good Indicator Output (open drain).
5	GND	Ground.
6	ISETA	Wall Adaptor Supply Charge Current Set Point.
7	ISETU	USB Supply Charge Current Set Input (active low).
8	$\overline{\text{EN}}$	Charge Enable Input (active low).
9	TS	Temperature Sense Input.
10	BATT	Battery Charge Current Output.
11 (Exposed Pad)	GND	The exposed pad must be soldered to a large PCB and connected to GND for maximum power dissipation.

**Function Block Diagram**

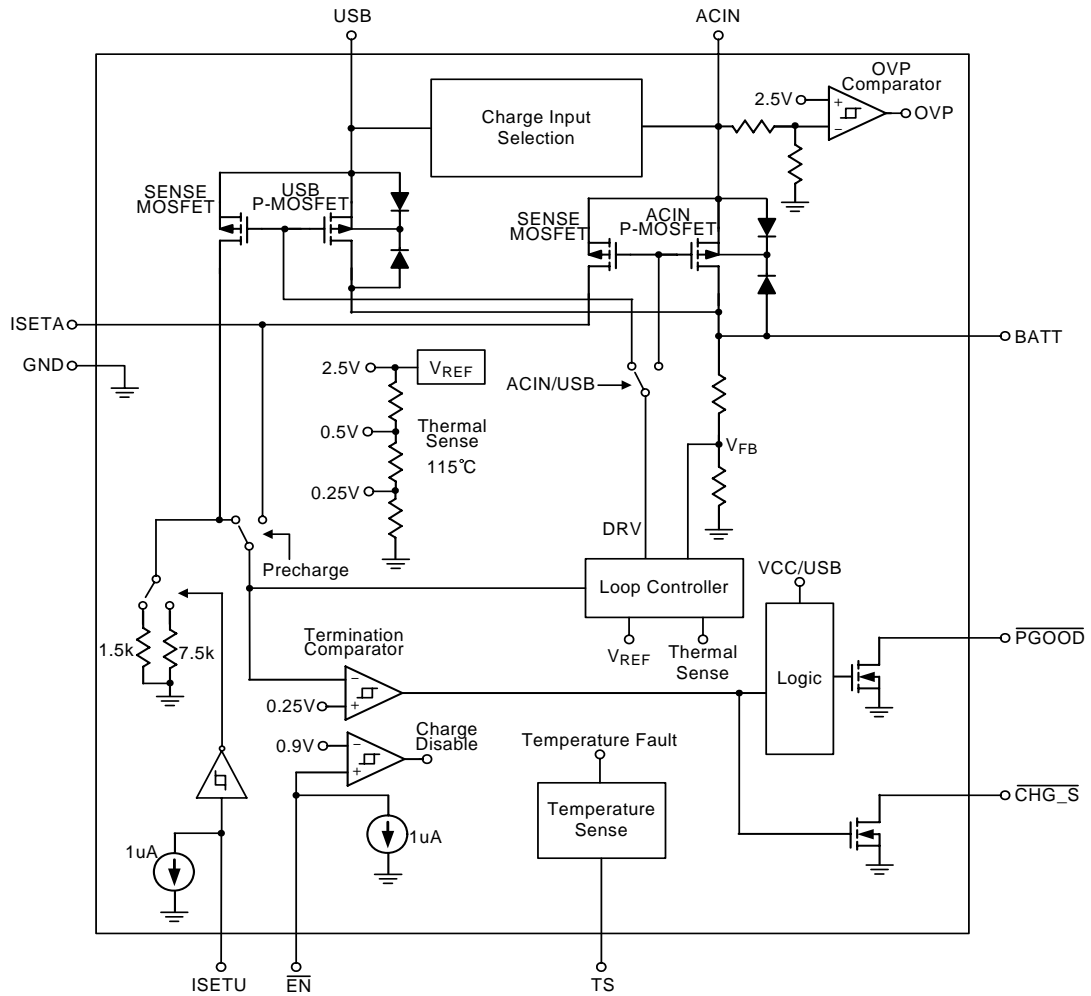

Table

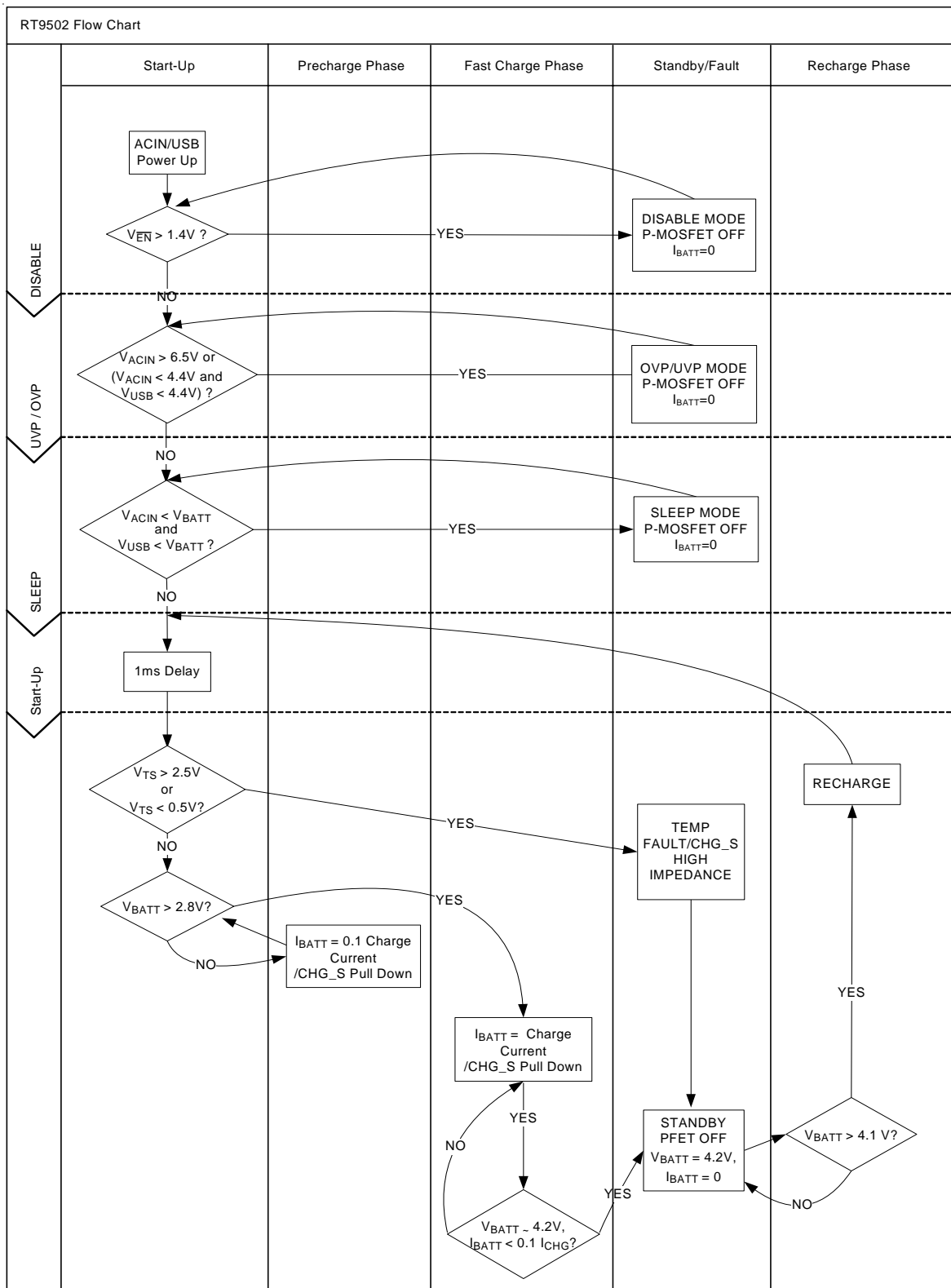

**Absolute Maximum Ratings** (Note 1)

- ACIN Input Voltage ----- -0.3V to 18V
- USB Input Voltage ----- -0.3V to 7V
- EN Input Voltage ----- -0.3V to 6V
- Output Current ----- 1.2A
- Power Dissipation, P<sub>D</sub> @ T<sub>A</sub> = 25°C  
 WDFN-10L 3x3 ----- 0.926W
- Package Thermal Resistance (Note 2)  
 WDFN-10L 3x3, θ<sub>JA</sub> ----- 108°C/W  
 WDFN-10L 3x3, θ<sub>JC</sub> ----- 8.2°C/W
- Lead Temperature (Soldering, 10 sec.) ----- 260°C
- Junction Temperature ----- 150°C
- Storage Temperature Range ----- -65°C to 150°C
- ESD Susceptibility (Note 3)  
 HBM (Human Body Mode) ----- 2kV  
 MM (Machine Mode) ----- 200V

**Recommended Operating Conditions** (Note 4)

- ACIN, USB Input Voltage Range ----- 4.5V to 6V
- Junction Temperature Range ----- -40°C to 125°C
- Ambient Temperature Range ----- -40°C to 85°C

**Electrical Characteristics**

(ACIN = USB = 5V, T<sub>A</sub> = 27°C, Unless Otherwise specification)

Parameter	Symbol	Test Conditions	Min	Typ	Max	Units
<b>Supply Input</b>						
ACIN/USB UVP Rising Threshold Voltage	V <sub>UV_HIGH</sub>		--	4.4	4.5	V
ACIN/USB UVP Hysteresis	V <sub>UV_LOW</sub>		50	80	120	mV
ACIN/USB Standby Current	I <sub>STBY</sub>	V <sub>BATT</sub> = 4.5V	--	300	500	uA
ACIN/USB Shutdown Current	I <sub>SHDN</sub>	V <sub>EN</sub> = High	--	50	100	uA
ACIN/USB UVP Current	I <sub>UVP</sub>	V <sub>ACIN</sub> = 4V, V <sub>USB</sub> = 4V, V <sub>BATT</sub> = 3V	--	150	250	uA
BATT Sleep Leakage Current	I <sub>SLEEP</sub>	V <sub>ACIN</sub> = 4V, V <sub>USB</sub> = 4V, V <sub>BATT</sub> = 4.5V	--	2	5	uA
<b>Voltage Regulation</b>						
BATT Regulation Voltage	V <sub>REG</sub>	I <sub>BATT</sub> = 60mA	4.158	4.2	4.242	V
Regulation Voltage Accuracy			-1	--	+1	%
ACIN MOSFET	R <sub>DS(ON)_ACIN</sub>	I <sub>BATT</sub> = 500mA	--	600	--	mΩ
USB MOSFET	R <sub>DS(ON)_USB</sub>	I <sub>BATT</sub> = 500mA	--	1200	--	mΩ
<b>Current Regulation</b>						
ISETA Set Voltage (Fast Charge Phase)	V <sub>ISETA</sub>	V <sub>BATT</sub> = 3.5V	2.42	2.5	2.55	V
Full Charge setting range	I <sub>CHG_ACIN</sub>		100	--	1200	mA

*To be continued*

Parameter	Symbol	Test Conditions	Min	Typ	Max	Units	
ACIN Charge Current accuracy	I <sub>CHG_ACIN</sub>	V <sub>BATT</sub> = 3.8V; R <sub>ISSET</sub> = 1.5kΩ	--	500	--	mA	
<b>Precharge</b>							
BATT Pre-charge Rising Threshold	V <sub>PRECH</sub>		2.6	2.8	3	V	
BATT Pre-charge Threshold Hysteresis	ΔV <sub>PRECH</sub>		50	100	200	mV	
Pre-Charge Current	I <sub>PCHG</sub>	V <sub>BATT</sub> = 2V	8	10	12	%	
<b>Recharge Threshold</b>							
BATT Re-charge Falling Threshold Hysteresis	ΔV <sub>RECH_L</sub>	V <sub>REG</sub> - V <sub>BATT</sub>	60	100	150	mV	
<b>Charge Termination Detection</b>							
ISETA Charge Termination Set Voltage	V <sub>TERM</sub>	V <sub>BATT</sub> = 4.2V	200	250	275	mV	
Termination Current Ratio (default)	I <sub>TERM</sub>	V <sub>BATT</sub> = 4.2V	--	10	--	%	
<b>Logic Input/Output</b>							
CHG_S Pull Down Voltage	V <sub>CHG_S</sub>	TBD; I <sub>CHG_S</sub> = 5mA	--	65	--	mV	
PGOOD Pull Down Voltage	V <sub>PGOOD</sub>	TBD; I <sub>PGOOD</sub> = 5mA	--	220	--	mV	
EN Threshold	Logic-High Voltage	V <sub>IH</sub>	1.5	--	--	V	
	Logic-Low Voltage	V <sub>IL</sub>	--	--	0.4	V	
EN Pin Input Current	I <sub>EN</sub>	V <sub>EN</sub> = 2V	--	--	2	uA	
ISETU Threshold	High Voltage	V <sub>ISETU_HIGH</sub>	1.5	--	--	V	
	Low Voltage	V <sub>ISETU_LOW</sub>	--	--	0.4	V	
ISETU Pin Input Current	I <sub>ISETU</sub>	V <sub>ISETU</sub> = 2V	--	--	2	uA	
<b>USB Charge Current &amp; Timing</b>							
USB Charge Current	I <sub>CHG(USB100)</sub>	V <sub>USB</sub> = 5V; V <sub>BATT</sub> = 3.5V, I <sub>SETU</sub> = 0V	--	--	100	mA	
	I <sub>CHG(USB500)</sub>	V <sub>USB</sub> = 5V; V <sub>BATT</sub> = 3.5V, I <sub>SETU</sub> = 5V	400	450	500		
<b>Battery Temperature Sense</b>							
TS Pin Source Current	I <sub>TS</sub>	V <sub>TS</sub> = 1.5V	96	102	108	uA	
TS Pin Threshold	Low Voltage	V <sub>TS_LOW</sub>	Falling	0.485	0.5	0.515	V
	High Voltage	V <sub>TS_HIGH</sub>	Rising	2.45	2.5	2.55	V
<b>Protection</b>							
Thermal Regulation			--	125	--	°C	
OVP SET		Internal Default	--	6.5	--	V	

**Note 1.** Stresses listed as the above "Absolute Maximum Ratings" may cause permanent damage to the device. These are for stress ratings. Functional operation of the device at these or any other conditions beyond those indicated in the operational sections of the specifications is not implied. Exposure to absolute maximum rating conditions for extended periods may remain possibility to affect device reliability.

**Note 2.**  $\theta_{JA}$  is measured in the natural convection at  $T_A = 25^\circ\text{C}$  on a high effective thermal conductivity test board (4 layers, 1S) of JEDEC 51-7 thermal measurement standard. The case point of  $\theta_{JC}$  is on the expose pad for the package.

**Note 3.** Devices are ESD sensitive. Handling precaution is recommended.

**Note 4.** The device is not guaranteed to function outside its operating conditions.

## Typical Operating Characteristics

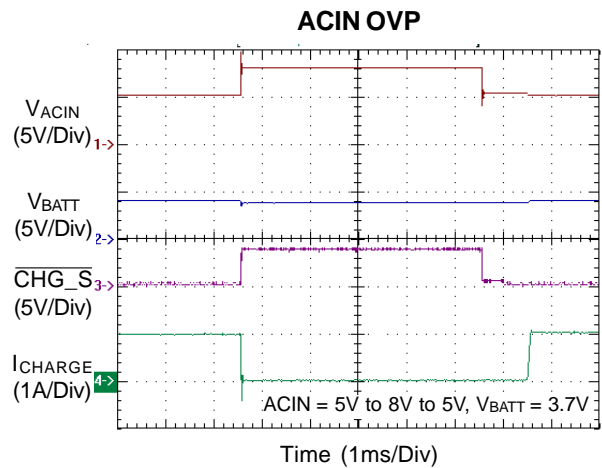
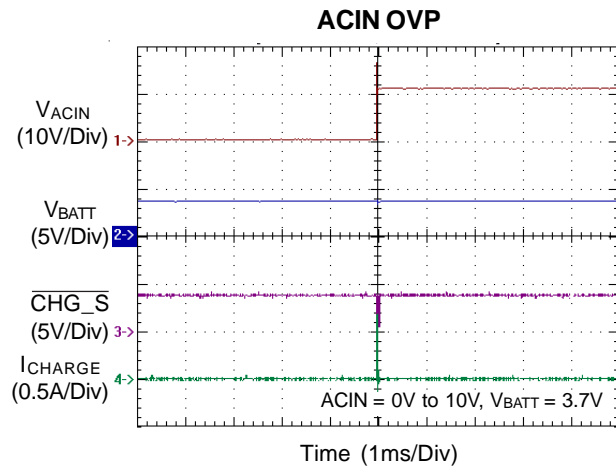
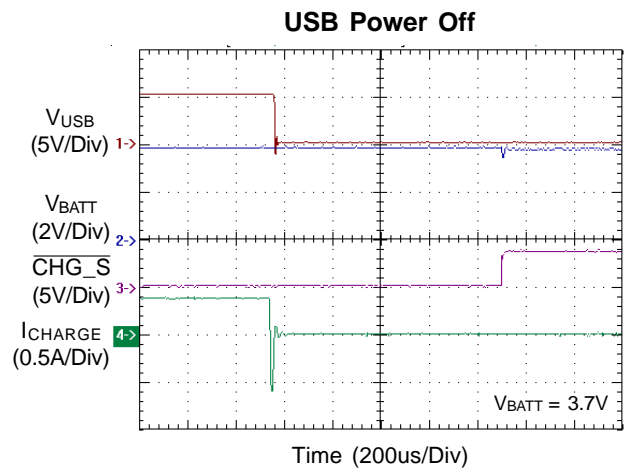
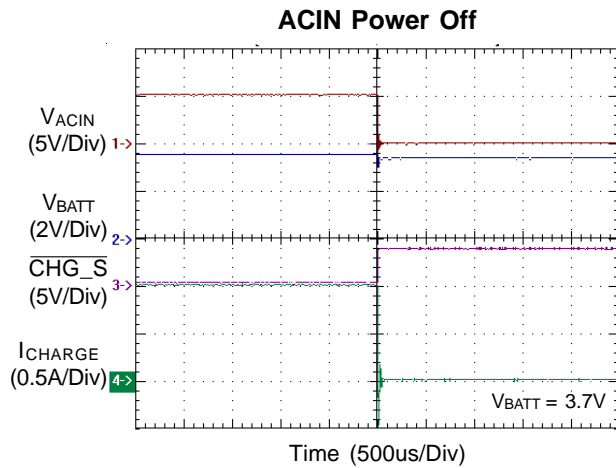
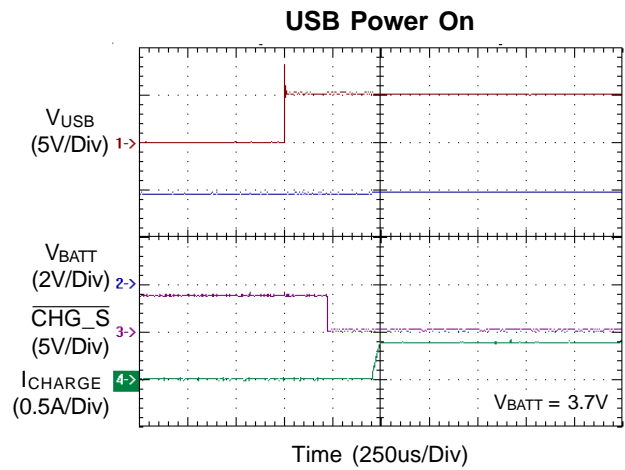
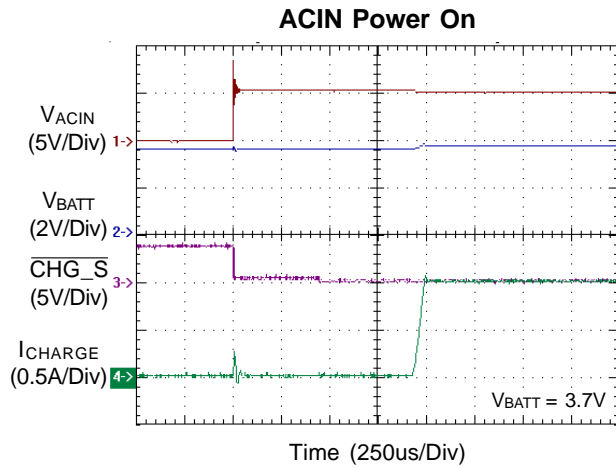



**Input Voltage Transition**

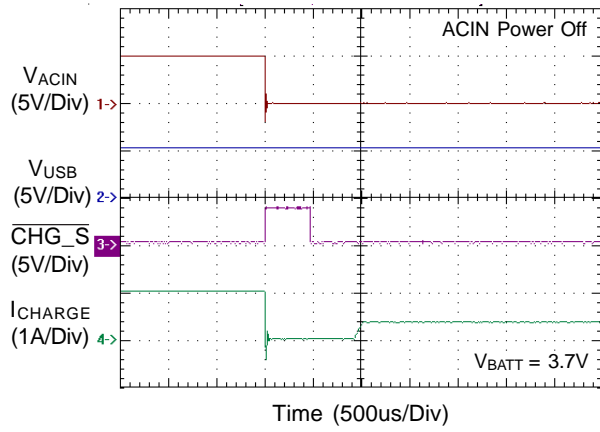

**Input Voltage Transition**

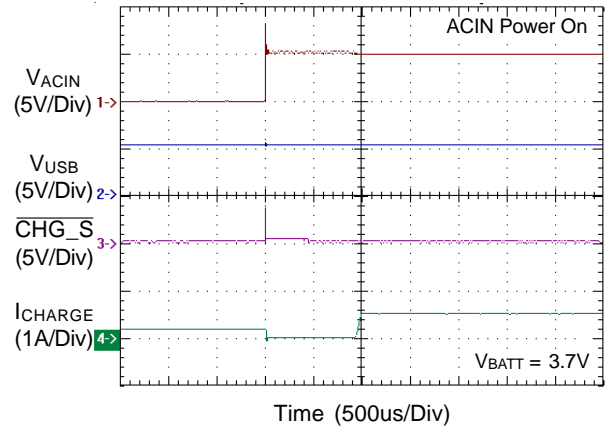

## Application Information

### Automatically Power Source Selection

The RT9502 is a battery charger IC which is designed for Li-ion Battery with 4.2V rated voltage.

The RT9502 can be adopted for two input power source, ACIN or USB Input. It will automatically select the input source and operate in different mode as below.

**ACIN Mode :** When the ACIN input voltage (ACIN) is higher than the UVP voltage level (4.4V), the RT9502 will enter ACIN Mode. In the ACIN Mode, ACIN P-MOSFET is turned on and USB P-MOSFET is turned off.

**USB Mode :** When ACIN input voltage is lower than UVP voltage level and USB input voltage is higher than UVP voltage level (4.4V), the RT9502 will operate in the USB Mode. In the USB Mode, ACIN P-MOSFET is turned off and USB P-MOSFET is turned on.

**Sleep Mode :** The RT9502 will enter Sleep Mode when both ACIN and USB input voltage are removed. This feature provides low leakage current from the battery during the absence of input supply.

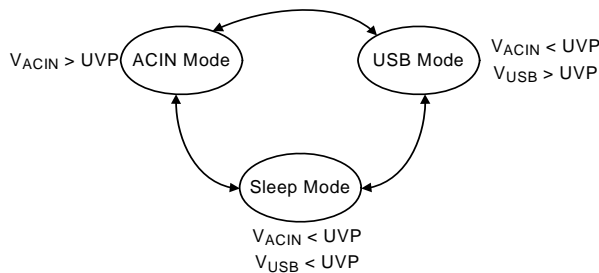

Figure 1. Input Power Source Operation Mode.

### ACIN Over Voltage Protection

The ACIN input voltage is monitored by an internal OVP comparator. The comparator has an accurate reference of 2.5V from the band-gap reference. The OVP threshold is set by the internal resistive. The protection threshold is set to 6.5V. When the input voltage exceeds the threshold, the comparator outputs a logic signal to turn off the power P-MOSFET to prevent the high input voltage from damaging the electronics in the handheld system. When the input over voltage condition is removed (ACIN < 6V), the comparator re-enables the output by running through the soft-start.

### Battery Temperature Monitoring

The RT9502 continuously monitors battery temperature by measuring the voltage between the TS and GND pins. The RT9502 has an internal current source to provide the bias for the most common 10kΩ negative-temperature coefficient thermal resistor (NTC) (see Figure 2). The RT9502 compares the voltage on the TS pin against the internal VTS\_HIGH and VTS\_LOW thresholds to determine if charging is allowed.

When the temperature outside the VTS\_HIGH and VTS\_LOW thresholds is detected, the device will immediately stop the charge. The RT9502 stops charge and keep monitoring the battery temperature when the temperature sense input voltage is back to the threshold between VTS\_HIGH and VTS\_LOW, the charger will be resumed. Charge is resumed when the temperature returns to the normal range. However the user may modify thresholds by the negative-temperature coefficient thermal resistor or adding two external resistors. (see Figure 3.)

The capacitor should be placed close to TS(Pin 9) and connected to the ground plane. The capacitance value (0.1uF to 10uF) should be selected according to the quality of PCB layout. It is recommended to use 10uF if the layout is poor if prevent noise.

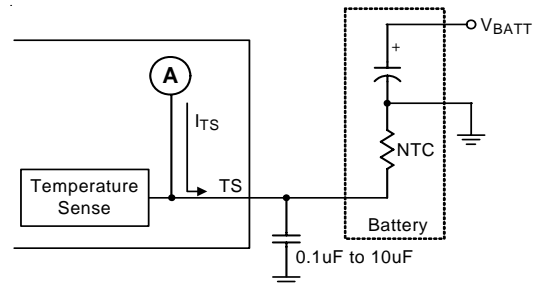

$$V_{TS} = I_{TS} \times R_{NTC}$$

Turn off when  $V_{TS} \geq 2.5V$  or  $V_{TS} \leq 0.5V$

Figure 2. Temperature Sensing Configuration

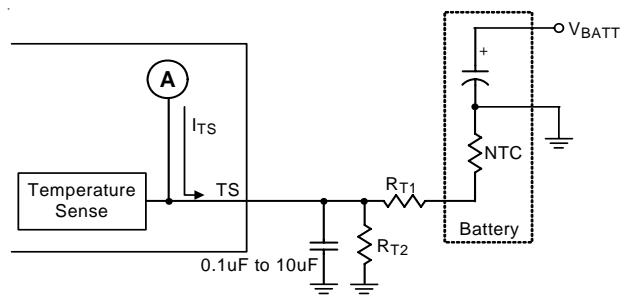

$$V_{TS} = I_{TS} \frac{R_{T2} \times (R_{T1} + R_{NTC})}{R_{T1} + R_{T2} + R_{NTC}}$$

Turn off when  $V_{TS} \geq 2.5V$  or  $V_{TS} \leq 0.5V$

Figure 3. Temperature Sensing Circuit

**Fast-Charge Current Setting**

**Case 1 : ACIN Mode**

The RT9502 offers ISETA pin to determine the ACIN charge rate from 100mA to 1.2A. The charge current can be calculated as following equation.

$$I_{charge\_ac} = K_{SET} \frac{V_{SET}}{R_{SETA}}$$

The parameter  $K_{SET} = 300$  ;  $V_{SET} = 2.5V$ .  $R_{SETA}$  is the resistor connected between the ISETA and GND.

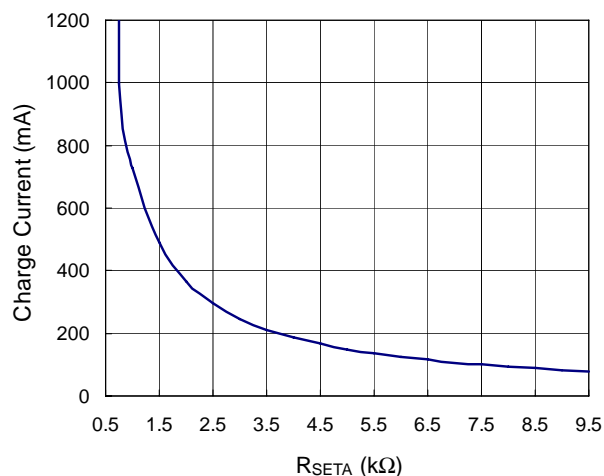

Figure 4. ACIN Mode Charge Current Setting

**Case 2 : USB Mode**

When charging from a USB port, the ISETU pin can be used to determine the charge current of 100mA or 500mA.

A low-level signal of ISETU pin sets the charge current at 100mA and a high level signal sets the charge current at 500mA.

**Pre- Charge Current Setting**

During a charge cycle if the battery voltage is below the VPRECH threshold, the RT9502 applies a pre-charge mode to the battery. This feature revives deeply discharged cells and protects battery life. The RT9502 internal determines the pre-charge rate as 10% of the fast-charge current.

**Battery Voltage Regulation**

The RT9502 monitors the battery voltage through the BATT pin. Once the battery voltage level closes to the VREG threshold, the RT9502 voltage enters constant phase and the charging current begins to taper down. When battery voltage is over the VREG threshold, the RT9502 will stop charge and keep to monitor the battery voltage. However, when the battery voltage decreases 100mV below the V<sub>REG</sub>, it will be recharged to keep the battery voltage.

**Charge Status Outputs**

The open-drain  $\overline{CHG\_S}$  and  $\overline{PGOOD}$  outputs indicate various charger operations as shown in the following table.

These status pins can be used to drive LEDs or communicate to the host processor. Note that ON indicates the open-drain transistor is turned on and LED is bright.

Charge State		$\overline{CHG\_S}$	$\overline{PGOOD}$
ACIN	Charge	ON	ON
	Charge done	OFF	ON
USB	Charge	ON	OFF
	Charge done	OFF	OFF

### Temperature Regulation and Thermal Protection

In order to maximize the charge rate, the RT9502 features a junction temperature regulation loop. If the power dissipation of the IC results in a junction temperature greater than the thermal regulation threshold (125°C), the RT9502 throttles back on the charge current in order to maintain a junction temperature around the thermal regulation threshold (125°C). The RT9502 monitors the junction temperature,  $T_J$ , of the die and disconnects the battery from the input if  $T_J$  exceeds 125°C. This operation continues until junction temperature falls below thermal regulation threshold (125°C) by the hysteresis level. This feature prevents the chip from damage.

### Selecting the Input and Output Capacitors

In most applications, the most important is the high-frequency decoupling capacitor on the input of the RT9502. A 1 $\mu$ F ceramic capacitor, placed in close proximity to input pin and GND pin is recommended. In some applications depending on the power supply characteristics and cable length, it may be necessary to add an additional 10 $\mu$ F ceramic capacitor to the input. The RT9502 requires a small output capacitor for loop stability. A 1 $\mu$ F ceramic capacitor placed between the BATT pin and GND is typically sufficient.

### Layout Consideration

The RT9502 is a fully integrated low cost single-cell Li-Ion battery charger ideal for portable applications. Careful PCB layout is necessary. For best performance, place all peripheral components as close to the IC as possible. A short connection is highly recommended. The following guidelines should be strictly followed when designing a PCB layout for the RT9502.

- ▶ Input capacitor should be placed close to IC and connected to ground plane. The trace of input in the PCB should be placed far away the sensitive devices or shielded by the ground.
- ▶ The GND should be connected to a strong ground plane for heat sinking and noise protection.
- ▶ The connection of  $R_{SETA}$  should be isolated from other noisy traces. The short wire is recommended to prevent EMI and noise coupling.

- ▶ Output capacitor should be placed close to IC and connected to ground plane to reduce noise coupling.
- ▶ The TS's capacitor should be placed close to TS (Pin 9) and connected to ground plane. The capacitance (0.1 $\mu$ F to 10 $\mu$ F) base on PCB layout. When PCB has poor layout, the 10 $\mu$ F is recommended to prevent noise.

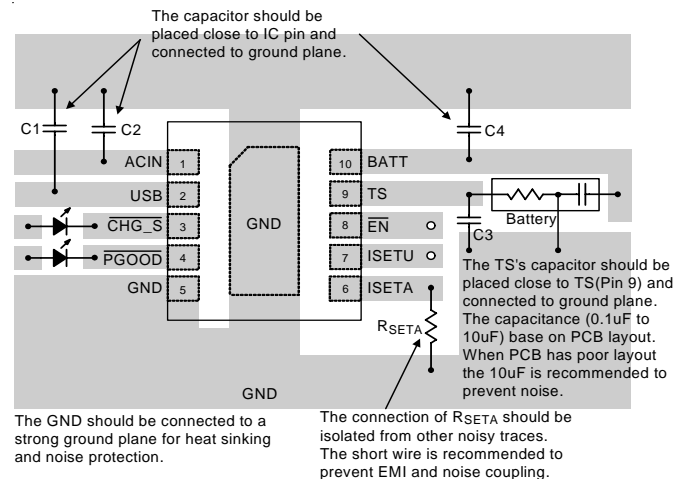
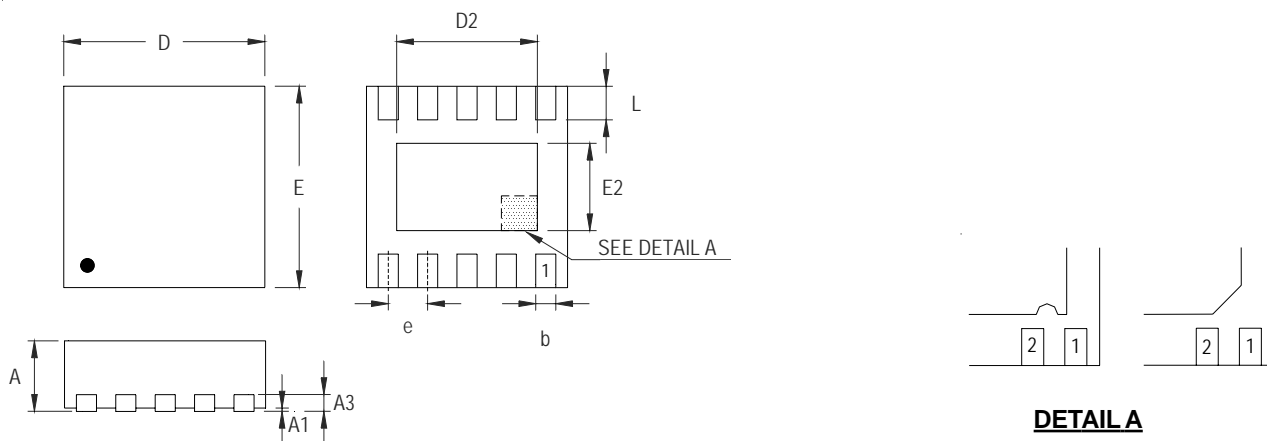

Figure 5

**Outline Dimension**



**DETAIL A**

Pin #1 ID and Tie Bar Mark Options

Note : The configuration of the Pin #1 identifier is optional, but must be located within the zone indicated.

Symbol	Dimensions In Millimeters		Dimensions In Inches	
	Min	Max	Min	Max
A	0.700	0.800	0.028	0.031
A1	0.000	0.050	0.000	0.002
A3	0.175	0.250	0.007	0.010
b	0.180	0.300	0.007	0.012
D	2.950	3.050	0.116	0.120
D2	2.300	2.650	0.091	0.104
E	2.950	3.050	0.116	0.120
E2	1.500	1.750	0.059	0.069
e	0.500		0.020	
L	0.350	0.450	0.014	0.018

**W-Type 10L DFN 3x3 Package**

**Richtek Technology Corporation**

Headquarter  
 5F, No. 20, Taiyuen Street, Chupei City  
 Hsinchu, Taiwan, R.O.C.  
 Tel: (8863)5526789 Fax: (8863)5526611

**Richtek Technology Corporation**

Taipei Office (Marketing)  
 5F, No. 95, Minchiuan Road, Hsintien City  
 Taipei County, Taiwan, R.O.C.  
 Tel: (8862)86672399 Fax: (8862)86672377  
 Email: marketing@richtek.com

Information that is provided by Richtek Technology Corporation is believed to be accurate and reliable. Richtek reserves the right to make any change in circuit design, specification or other related things if necessary without notice at any time. No third party intellectual property infringement of the applications should be guaranteed by users when integrating Richtek products into any application. No legal responsibility for any said applications is assumed by Richtek.