



GBPC 40, 50 SERIES

High Current 40, 50 AMPS. Single Phase Glass Passivated Bridge Rectifiers



Voltage Range
50 to 1000 Volts
Current
40, 50.0 Amperes

Features

- ✧ UL Recognized File # E-96005
- ✧ The plastic material used carries Underwriters Laboratory Flammability Recognition 94V-0
- ✧ Integrally molded heatsink provide very low thermal resistance for maximum heat dissipation
- ✧ Universal 4-way terminals; snap-on, wrap-around, solder or P.C. board mounting
- ✧ Surge overload ratings 400 amperes
- ✧ Terminals solderable per MIL-STD-202, Method 208
- ✧ Typical I_R less than 0.2 μ A
- ✧ High temperature soldering guaranteed: 260°C/ 10 seconds / .375", (9.5mm) lead lengths
- ✧ Isolated voltage from case to lead over 2500 volts

GBPC40

GBPC40-M

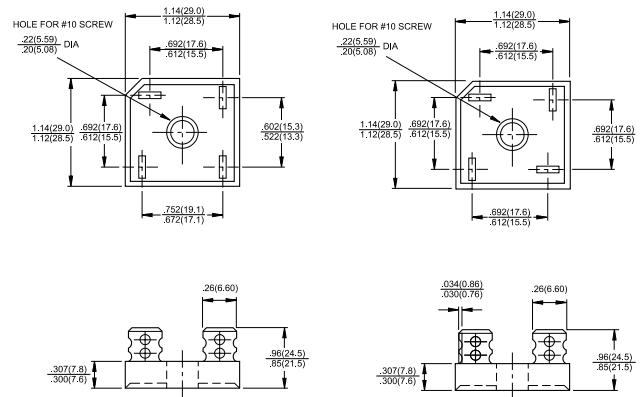

Dimensions in inches and (millimeters)

Maximum Ratings and Electrical Characteristics

Rating at 25°C ambient temperature unless otherwise specified.
Single phase, half wave, 60 Hz, resistive or inductive load.
For capacitive load, derate current by 20%

Type Number	-005	-01	-02	-04	-06	-08	-10	Units
Maximum Recurrent Peak Reverse Voltage	50	100	200	400	600	800	1000	V
Maximum RMS Voltage	35	70	140	280	420	560	700	V
Maximum DC Blocking Voltage	50	100	200	400	600	800	1000	V
Maximum Average Forward Rectified Current @ $T_C = 55^\circ\text{C}$	GBPC40 40.0 GBPC50 50.0							A
Peak Forward Surge Current, Single Sine-wave Superimposed on Rated Load (JEDEC method)	GBPC40 400 GBPC50 400							A
Maximum Instantaneous Forward Voltage Drop Per Element at Specified Current	GBPC40 @20A 1.1 GBPC50 @25A							V
Maximum DC Reverse Current at Rated DC Blocking Voltage Per Element	10							μ A
Typical Thermal Resistance (Note 1) $R\theta_{JC}$	1.5							$^\circ\text{C/W}$
Operating and Storage Temperature Range T_J, T_{STG}	-50 to +150							$^\circ\text{C}$

Notes: 1. Thermal Resistance from Junction to Case.
2. Suffix "M" - Terminal Location Face to Face.

RATINGS AND CHARACTERISTIC CURVES (GBPC4005 THRU GBPC4010) (GBPC50005 THRU GBPC5010)

FIG.1- MAXIMUM FORWARD CURRENT DERATING CURVE

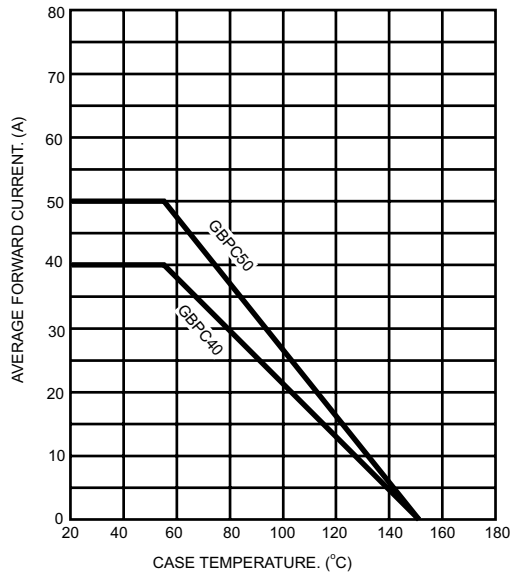

FIG.2- MAXIMUM NON-REPETITIVE FORWARD SURGE CURRENT

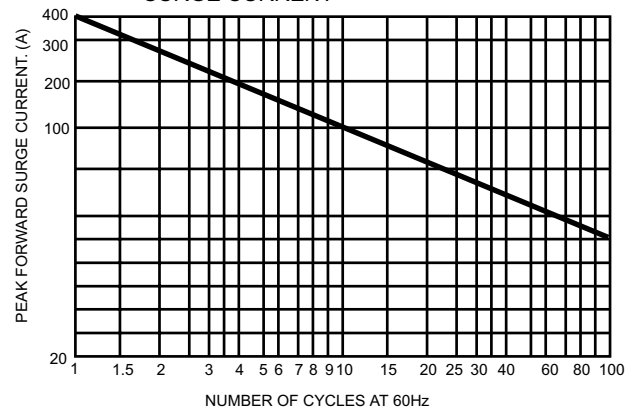

FIG.3- TYPICAL REVERSE CHARACTERISTICS PER BRIDGE ELEMENT

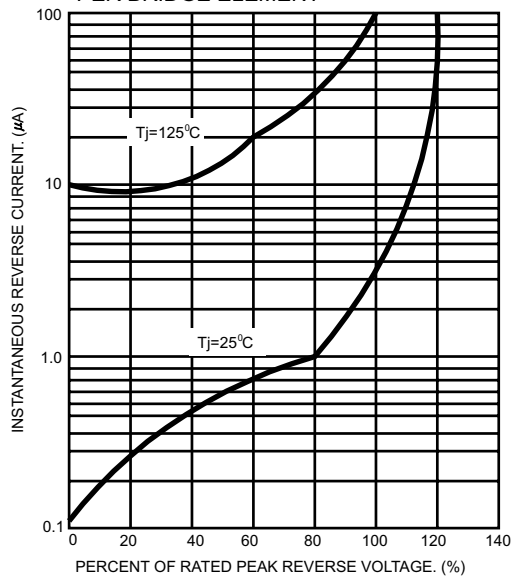

FIG.4- TYPICAL FORWARD CHARACTERISTICS PER BRIDGE ELEMENT

